



Danger

Inverter must be earthed reliably. Otherwise, potential risk resulting in personal injury may occur inside the device.

Intended Readers

The User Manual is intended for the readers below:

Inverter installation personnel, engineers and technicians (electrical engineers and electrical operators), and designers, etc.

Please ensure the User Manual is received by end user.

Conventions



Symbol Convention

Caution Situations where moderate injury or minor injury may be resulted from operation not conforming to requirements.



Danger Situations where death or serious injury may be resulted from operation not conforming to requirements.

Preface

Thank you for choosing the Smart series inverter developed by our company.

Adopting magnetic flux vector control technology, the Smart series inverter can still realize controlling motor with high performance on condition that it is insensitive to motor parameters. It is characterized by full range high torque output, rapid response, excellent load adaptability, high speed control precision and sound reliability, which is an ideal choice for high-performance general inverter satisfying higher requirements on site.

The Smart series inverter combines customers' general needs with industrial needs in organic way, provides multiple powerful features including practical PID regulator, constant pressure water supply, simple PLC and programmable input/output terminal control, pulse frequency assignment and other control functions dedicated to the inverter. It offers an integrated solution at high level of integration to customers in equipment manufacturing and automation engineering industry, so it has high value in reducing system cost and up system reliability.

The User Manual provides guidance for equipment installation, running parameter settings, malfunction diagnosis, daily maintenance and safe use. To install and operate this series products correctly, please read this User Manual before use. It is delivered with our product. Please keep properly for later use.

For any problem not solved when using this inverter, please contact local dealer or directly contact our customer service center.

The User Manual is subject to change without prior notice. The new edition shall prevail.

— Content —

Chapter 1 General

1.1 Product Confirmation.....	(1-1)
1.2 Precautions for Safety.....	(1-2)
1.3 Precautions for Use.....	(1-3)
1.4 Precautions for Abandonment.....	(1-4)

Chapter 2 Product Specifications and Ordering Instructions

2.1 Inverter Types.....	(2-1)
2.2 Technical Specifications.....	(2-2)
2.3 Instruction to Inverter Appearance.....	(2-4)
2.4 Appearance and Installation Dimension.....	(2-5)
2.5 Operation Panel and Holder.....	(2-6)
2.6 Brake Resistor Selection.....	(2-6)

Chapter 3 Inverter Installation and Wiring

3.1 Installation Environment.....	(3-1)
3.2 Panel Removal and Installation.....	(3-2)
3.3 Precautions for Wiring.....	(3-4)
3.4 Wiring of Main Circuit Terminal.....	(3-4)
3.5 Wiring Diagram for Basic Running.....	(3-8)
3.6 Configuration and Wiring of Control Circuit.....	(3-9)
3.7 Installation Instructions Complying with EMC Requirements.....	(3-13)
3.8 Standby Circuit.....	(3-17)

Chapter 4 Inverter Running and Operation Instruction

4.1 Inverter Running.....	(4-1)
4.2 Keyboard Operation and Use.....	(4-3)
4.3 Setting Method for Common Function Parameter Code.....	(4-5)
4.4 Setting Method for Special Function Parameter Code	(4-7)

Chapter 5 Function Parameter List

5.1 Function Parameters.....	(5-1)
------------------------------	-------

Chapter 6 Detailed Description of Parameter Use

6.1 Parameter Group F0(F0.00—F0.15) for Basic Running.....	(6-1)
---	-------

6.2 Parameter Group F1(F1.0000—F1.18) for Assist Running.....	(6-9)
6.3 Parameter Group F2 (F2.00—F2.08) for V/F Control.	(6-15)
6.4 Parameter Group F3 (F3.00—F3.07) for Motor	(6-17)
6.5 Parameter Group F4(F4.00—F4.07) for Performance Optimization.....	(6-19)
6.6 Parameter Group F5(F5.00—F5.22) for Switching Value Input/Output.....	(6-21)
6.7 Parameter Group F6 (F6.00—F6.18) for Analog and Pulse Input/Output.....	(6-32)
6.8 Process PID Parameter Group F7 (F7.00—F7.14)	(6-37)
6.9 Parameter Group F8 (F8.00—F8.16) for Programmable Operation.....	(6-42)
6.10 Parameter Group F9(F9.00—F9.09) for Protection	(6-47)
6.11 Parameter Group FA(FA.00—FA.18) for Supplementary Functions.....	(6-50)
6.12 Communication Parameter Group FB (FB.0FB.04)	(6-55)
6.13 Parameter Group FC for Monitoring and Display (FC.00—FC.07)	(6-56)

Chapter 7 Fault Diagnosis and Troubleshooting

7.1 Fault Inquiry.....	(7-1)
7.2 Fault Code.....	(7-3)
7.3 Abnormality Treatment.....	(7-4)

Chapter 8 Maintenance and Care

8.1 Daily Maintenance and Care.....	(8-1)
8.2 Periodic Maintenance and Care.....	(8-1)
8.3 Guarantee for Inverter.....	(8-2)

Annex 1: Communication Protocol..... (9-1)

Annex 2: Parameter Settings in Applied Situations..... (10-1)

Warranty Agreement..... (A-1)

Warranty Bill..... (A-2)

Chapter 1 General

1.1 Product Confirmation

When opening the package, please confirm carefully if any damage or scratch occurred in the transport or if the rated value of the machine on nameplate complies with your ordering requirement.

In case of any problem, please contact with your supplier or our company directly.

Description of Inverter Type:

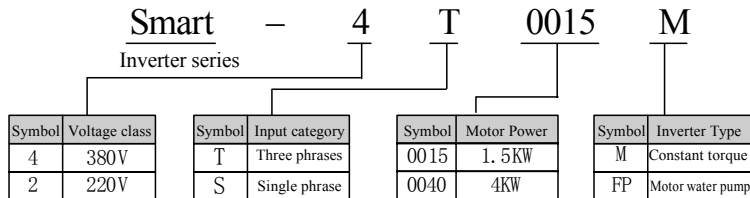

Fig. 1-1 Description of Inverter Type

The nameplate marked with inverter type and rated value is stamped at the lower part of the right side plate of the inverter case as shown below:

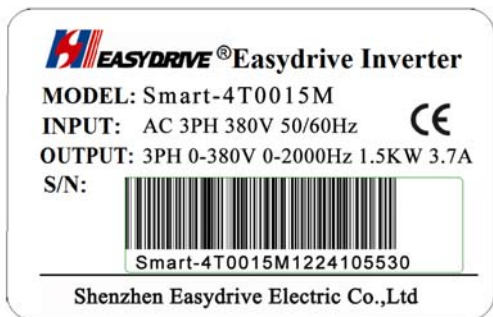

Fig. 1-2 Inverter Nameplate

1.2 Precautions for Safety

- Please confirm the product when receiving it.



1. Do not install any damaged inverter or the inverter with any part or accessory missed to avoid personal injury.

- Installation



1. Please hold the bottom of inverter when transporting. If only holding the panel, the main inverter body may drop with the risk of hurting foot.
2. Please install the inverter on the nonflammable plate. Or else, it may cause fire.
3. If to install two or more inverters in the same control cabinet, please equip cooling fan and keep the air temperature of the air inlet under 40°C, because overheat may cause fire or other accidents.

- Wiring



1. Please confirm that the input power has been cut off before wiring, or else it may cause electric shock or fire.
2. The wiring work shall be carried out by the professional electrical engineers, or else it may cause electric shock or fire.
3. The grounding terminal shall be earthed firmly and reliably to prevent electric shock.
4. When the emergency stop terminal is connected, do check its action is effective or not, or else it may cause injury (the wiring responsibility shall be taken by user).
5. Please do not touch output terminal directly. Do not connect the output terminal of inverter with the external housing and do not short-circuit output terminals, or else it may result in electric shock or short circuit.

**Caution**

1. Please confirm the power source of AC main circuit is in accordance with the rated voltage of inverter to avoid the risks of injury and fire.
2. Please do not carry out withstand voltage test to inverter, or else it may damage its components including semiconductor.
3. Please connect brake resistor or brake unit according to the wiring diagram, or else it may cause fire.
4. Please fasten terminals with screwdriver of the specified torque to avoid fire danger.
5. Please do not connect the input power line to the output terminals U, V and W. If the voltage connected to the output terminal, it may cause the internal damage of inverter.
6. Please do not connect phase-shifting capacitor and LC/RC noise filter to output circuit, or it may cause internal damage of inverter.
7. Please do not connect solenoid switch and electromagnetic contactor to the input circuit.

When the inverter is running in idle, the surge current caused by the activation of solenoid switch and electromagnetic contactor may lead to the overcurrent protection action of inverter.

- **Care and Maintenance**

**Danger**

1. Please do not touch the wiring terminal of inverter for it has high voltage, or else it may cause electric shock.
2. Before powering on, please do install the panel well but cut off power when dismantling the panel, or else it may cause electric shock.
3. Non-professional technicians are not allowed to carry out maintenance and inspection work, or else it may cause electric shock.

**Caution**

1. Special attention shall be paid when using CMOS integrated circuit for it is equipped with keyboard, control circuit board and drive circuit board. Do not touch circuit board directly by your finger, or else the resulted electrostatic induction may damage the integrated chip on circuit board.
2. When power on, do not change wiring and remove terminal wiring. When the inverter is running, do not check signal, or else it may damage the machine.

1.3 Precautions for Use

Attention shall be paid to the following aspects when using the Smart inverter:

1.3.1 Constant-torque Low-speed Run

If the inverter runs together with common motor at low speed for a long time, the work life of the motor will be influenced for poor cooling effect. So, if the motor needs to run at low speed with constant torque for a long time, the special variable frequency motor shall be used.

1.3.2 Confirmation of Motor Insulation

When applying the Smart inverter to drive motor, please confirm the insulation situation of the motor used first to avoid damaging the machine. In addition, in case the motor environment is much poor, please check its insulation situation regularly to ensure the system works safely.

1.3.3 Negative Torque Load

As for the application situation with strict requirements on the deceleration time of motor, the inverter may trip for overcurrent or overvoltage due to too short deceleration time. In this case, the optional brake resistor shall be considered.

1.3.4 Mechanical Resonance Points of Load Device

In the certain range of output frequency, the inverter may come into with the mechanical resonance point of load device, which shall be avoided by setting hopping frequency.

1.3.5 Capacitor or Voltage-sensitive Component to Improve Power Factor

For the output voltage of inverter is pulse wave type, any capacitor or lightning-proof voltage-sensitive component that can improve power factor shall be removed from the output side because it may cause fault trip of the inverter or component damage. In addition, it is suggested not to equip any switch component including air switch or contactor to the output side, as shown in Figure 1-3. (If the switch component needs to be connected to the output side, do ensure the output current of the inverter is 0 in case of any switch action).

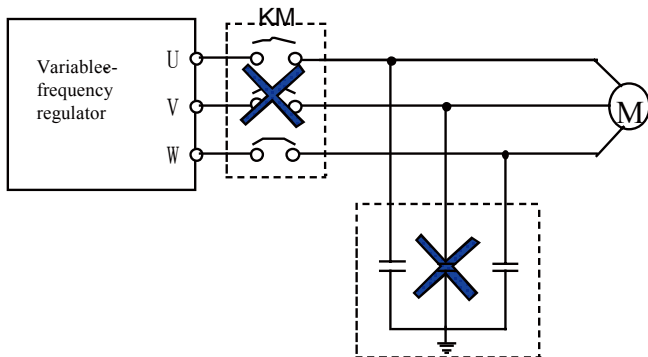

Fig. 1-3 Capacitor Prohibited at the Output Terminal of Inverter

1.3.6 Run by the Frequency over 50Hz

If the running frequency exceeds 50Hz, the vibration and noise of motor will increase. Besides, the working speed range of the motor shaft and mechanical device shall be confirmed. Therefore, do make inquiry in advance.

1.3.7 Electric Heat Protection Value of Motor

When selecting the applicable motor, the inverter can carry out heat protection to motor. If the motor does not match with the rated capacity of inverter, the protection value shall be adjusted or other protection measures shall be taken to ensure the safe run of motor.

1.3.8 Altitude and Derated Application

In the area with its altitude over 1000m, the inverter shall be applied by derating, because the thin air will decrease the cooling effect of inverter. Fig. 1-4 shows the relation curve between the rated current of inverter and altitude.

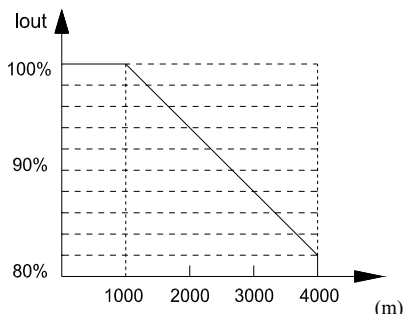

Fig. 1-4 Relation Curve between Rated Output Current of Inverter and Altitude

1.3.9 Protection Grade

The protection grade IP20 of the Smart inverter means the grade reached after installing keyboard.

1.4 Precautions for Abandonment

When abandoning the inverter, the attention shall be paid to the following aspects:

Explosion may happen when burning the electrolytic capacitor of the main circuit and that on the printed board. Toxic gas may generate after burning plastic pieces. So, please handle them as industrial refuse.

Chapter 2 Product Specifications and Ordering Instructions

2.1 Inverter Types

The Smart inverter has two voltages: 220V and 380V and its applicable motor power range is 380V: 0.75KW~4KW; 220V: 0.75KW~2.2KW. The types of the Smart inverter are as shown by the Table 2-1.

Table 2-1 Types of Smart Inverter

Voltage class	Inverter type	Rated current (A)	Applicable motor (KW)
380V Three phases	Smart-4T0007M	2.3	0.75
	Smart-4T0015M	3.7	1.5
	Smart-4T0022M	5.0	2.2
	Smart-4T0030M	7.2	3.0
	Smart-4T0040M	9.0	4.0
220V Single phase	Smart-2S0007M	4.0	0.75
	Smart-2S0015M	7.0	1.5
	Smart-2S0022M	10.0	2.2

Note: For other specifications in 220 voltage series, we can produce it as required by customers.

2.2 Technical Specifications

Item		Standard specifications
Input	Rated voltage and frequency	Single-phase 220V, 3-phase 380V, 50Hz
	Allowable variation	Voltage: -20% ~ +20% Voltage unbalance rate: <3% frequency: ±5%
Output	Rated voltage	0~220V/0~380V
	Frequency range	0Hz~2000Hz
	Overload capacity	M model: 150% 1 minute, 180% 1 second, 200%, transient protection;
Major control functions	Modulation mode	Optimizing space voltage vector PWM
	Control mode	Magnetic flux vector control and V/F control
	Frequency accuracy	Digital setting: max. frequency $\times \pm 0.01\%$; Analog setting: max. frequency $\times \pm 0.2\%$
	Frequency resolution	Digital setting: 0.1Hz; Analog setting: max. frequency $\times 0.1\%$
	Starting frequency	0.0Hz~10.00Hz
	Torque lifting	Automatic torque lifting, manual torque lifting 1%~30.0% (only effective to V/F control mode)
	V/F curve	Linear V/F curve, square V/F curve, custom V/F curve
	ACC/DEC time	Time unit is optional(minute/second). Max. 3600S (0.1~3600)
	DC brake	Start, respectively optional when stopping. Action frequency 0~upper limit frequency, action time setting: 0~30s
	Carrier frequency	1.0K~12KHZ
	Jog	Jog frequency range: 0.1Hz~50.00Hz, jog acceleration/deceleration time: 0.1~3600s
	Built-in PID	To form closed-loop control system easily, and applicable to pressure and flow controls.
	Multi-speed running	To realize multi-speed running by built-in PLC or control terminal
	Automatic voltage regulation	When the network voltage changes, adjust PWM output to keep the output voltage constant (AVR function)
	Automatic energy-saving running	Automatically optimize V/F curve based on loads and realize energy-saving running.
Automatic current limiting	Automatically limit current during running period to prevent frequent trips for overcurrent fault.	
Vector control	Torque characteristics	Output 200% rated torque at 1.5HZ
	Self-identification of motor parameter	Auto-recognize motor parameter to obtain the optimal control effect when the motor keeps still.

Item		Standard specifications
Running function	Run command channel	Operation panel assignment; control terminal assignment; communication assignment. switching by three ways.
	Frequency setting channel	Keyboard analog potentiometer assignment; Keys ▲ and ▼ assignment; digital assignment of function code; communication assignment; terminal UP/DOWN assignment; analog voltage assignment; analog current assignment; pulse assignment; combination assignment.
	Switching input channel	7 programmable switch inputs with max. 30 functions to set
	Analog input channel	AI1 , AI2 0~10V/0~20mA
	Analog output channel	1-way analog signal output, 0/4~20mA and 0/2~10V are optional, to realize the output of physical quantities including setting frequency and output frequency.
	On/off output channel	1-way programmable open collector output; 1-way relay output signal; multiple physical outputs are realized.
Operation panel	LED digital display	To display setting frequency, output voltage, output current and other parameters.
	External instrument display	Physical displays of output frequency, output current and output voltage, etc.
Protective function		Overcurrent protection; overvoltage protection; under-voltage protection; overheat protection; phase loss protection and overload protection, etc.
Options		Brake package; remote operation panel; remote cable; keyboard holder, etc.
Environment	Applicable place	Indoor, no direct sunlight, no dust and corrosive gas, oil mist and water steam, etc.
	Altitude	<1000m (to use by derating when more than 1000m)
	Environmental temperature	-10℃~+40℃
	Humidity	<90%RH, no condensation
	Vibration	<5.9m/s ²
	Storage temperature	-20℃~+60℃
Structure	Protection grade	IP20 (in the working status or keyboard display status)
	Cooling type	Forced air cooling
Installation method		Wall-mounted in cabinet

2.3 Appearance Instruction

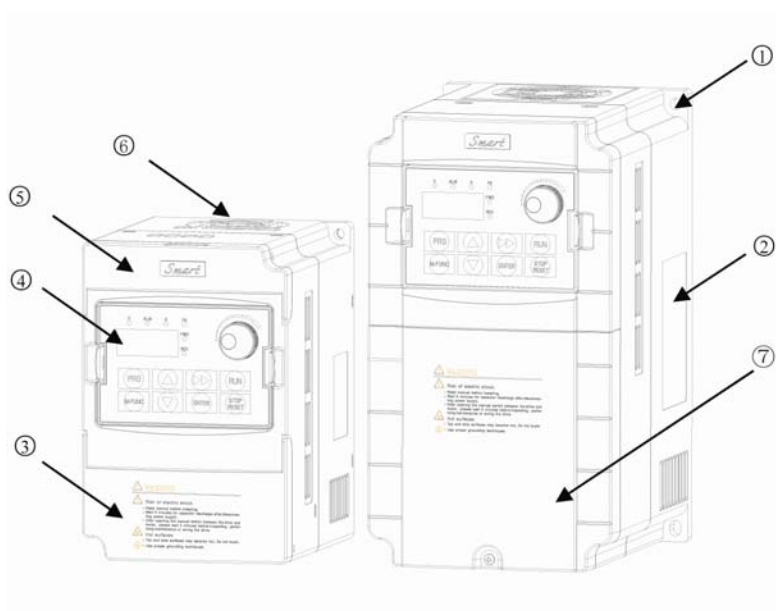

Fig.2-1 External View

- ①: Fixed screw holes
- ②: Brand
- ③: Wiring lower cover board
- ④: Operation panel
- ⑤: Wiring upper cover board
- ⑥: Heat-dissipation ventilation opening
- ⑦: Wiring lower cover board

2.4 Appearance and Installation Dimension

Specification	W	W1	H	H1	H2	D	D1	D2	D3	Diameter of mounting	Reference diagram
Smart-4T0007M	100	89	151	140		140	135	101.5	91	Φ5	(a)
Smart-2S0070M											
Smart-4T0015M											
Smart-2S0015M											
Smart-4T0022M											
Smart-2S0022M	120	108	215	202	154	150	116		Φ5.5	(b)	
Smart-4T0030M											
Smart-4T0040M											

Appearance Dimension Diagram

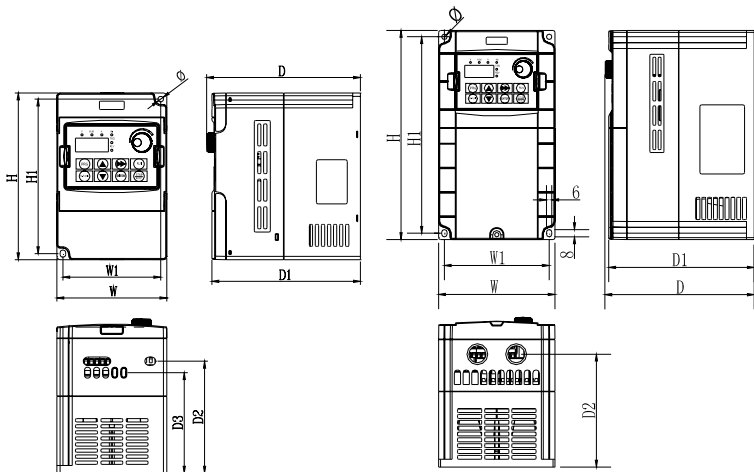

(a) 0.7KW-2.2KW external dimension

(b) 3KW-4KW external dimension

2.5 Operation Panel and Holder (Unit: mm)

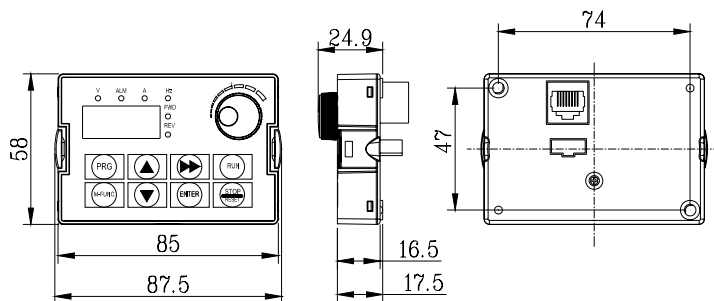

Fig. 2-2 Smart Keyboard Dimension (Native Machine and Remote Control)

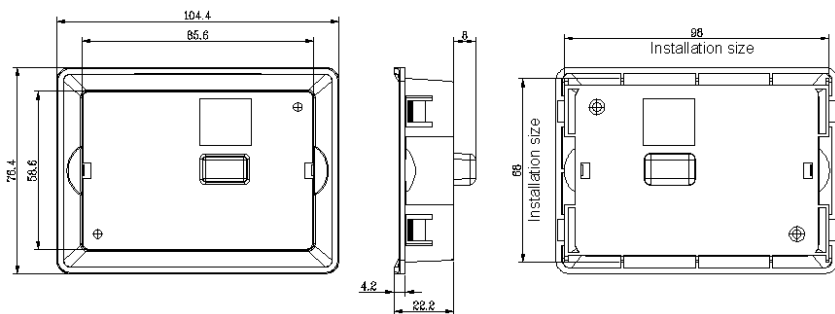

Fig. 2-3 Size of Smart Remote-Control Keyboard Holder (Options)

2.6 Brake Resistor

The brake unit of the SMART inverter is optional. If required, please point out when ordering. The dynamic braking resistor shall be equipped according to the Table 2-4. The wiring of brake resistor shall be carried out according to the Fig. 2-4.

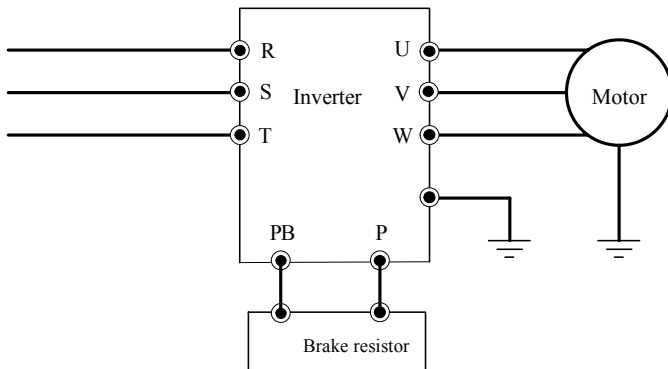

Fig. 2-4 Wiring Diagram of Inverter and Brake Component

Table 2-4 Brake Resistor Table

Model	Applicable motor power (KW)	Resistance (Ω)	Resistance power (W)
Smart-4T0007M	0.75	300	100
Smart-4T0015M	1.5	300	200
Smart-4T0022M	2.2	200	200
Smart-4T0030M	3.0	200	300
Smart-4T0040M	4.0	150	400

Instruction:

The wiring length of brake resistor shall be less than 5m. The temperature of brake resistor will increase due to energy feed in the process of energy brake, and so attention shall be paid to safety protection and ventilation during installing.

Chapter 3 Inverter Installation and Wiring

3.1 Installation Environment

3.1.1 Requirements on Installation Environment

- (1) Install indoor with good ventilation. Environmental temperature range: $-10^{\circ}\text{C}\sim 40^{\circ}\text{C}$. If the temperature exceeds 40°C , the forced external cooling shall be carried out or the inverter shall be derated for application.
- (2) Avoid to install in the place with direct sunlight, dust, floating fiber and metal powder.
- (3) It is strictly prohibited to install inverter in the place with corrosive or explosive gases.
- (4) The humidity shall be lower than 90% without condensation.
- (5) Install in the place with firm plane and vibration less than 5.9m/s^2 .
- (6) Keep away as possible from the electromagnetic interference source or other electronic instruments sensitive to electromagnetic interference.

3.1.2 Installation Direction and Space

- (1) Install vertically in general condition.
- (2) The installation spacing and the min. distance is as shown in Fig.3-1.
- (3) If multiple inverters are installed up to down, baffle plate shall be applied between them as shown in Fig. 3-2.

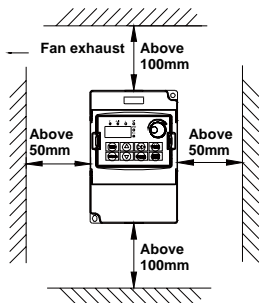

Fig. 3-1 Installation Spacing Diagram

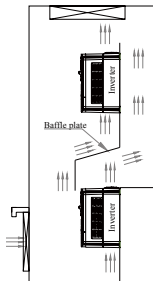

Fig. 3-2 Installation Diagram of Multiple Inverters

3.2 Panel Removal and Installation

3.2.1 Removal and Installation of Operation Panel

◆ Removal of Operation Panel

Press the grab of operation panel by force to direction 1 as shown in the Fig. 3-3 and lift the operation panel to direction 2.

◆ Installation of Operation Panel

Press the both sides with force to direction 1 as shown in Fig. 3-4, and press down the operation panel to direction 2 until “click” is heard. Do not install the operation panel from other directions, or else it may result in the poor contact of operation panel.

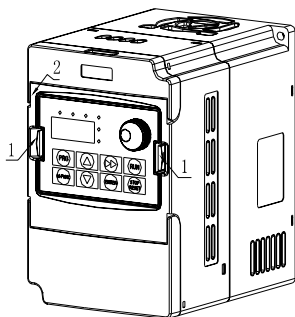

Fig.3-3 Removal of Operation Panel

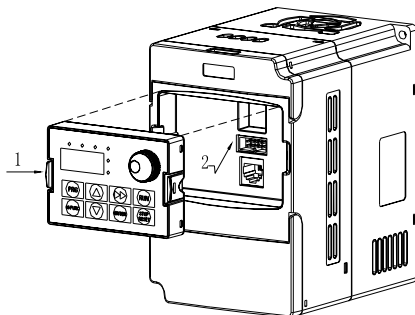

Fig. 3-4 Installation of Operation Panel

3.2.2 Remove and install cover board

(1) 0.7-1.5KW(220V)、0.7-2.2KW(380V) model

◆ Open upper and lower cover board

Lift upper cover board to direction 1 as shown in Fig. 3-5. Lift upper cover board to direction 2 as shown in Fig. 3-5.

◆ Close upper and lower cover board

Press down to direction 1 and 2 as shown in Fig. 3-6 until “click” is heard.

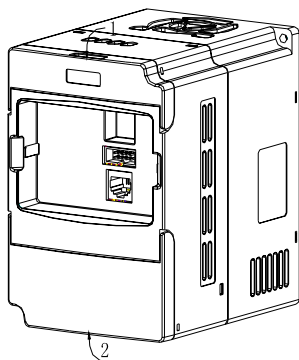

Fig. 3-5 Open Upper and Lower Cover Board

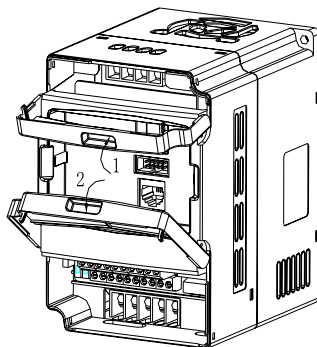

Fig. 3-6 Close Upper and Lower Cover Board

(2) 2.2KW(220V)、3-4KW(380V) model

◆ Remove cover board

Remove screws in direction 3 as shown in Fig.3-7. Lift cover board to direction 1 while press both sides of cover board to direction 1.

◆ Install cover board

Insert the buckle on cover board into the groove of main body to direction 2 as shown in Fig. 3-8, and press cover board to direction 1 until hearing "click". Tighten screws in direction 3.

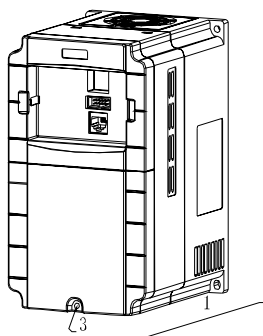

Fig. 3-7 Removal of Cover Board

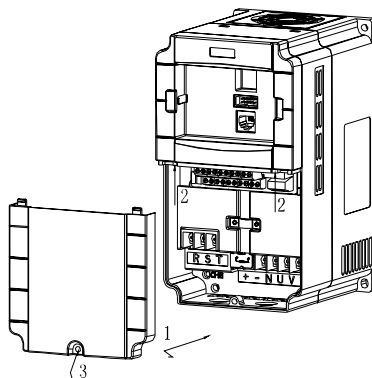

Fig. 3-8 Installation of Cover Board

3.3 Precautions for Inverter Wiring

⚠ Caution

- (1) Ensure that power source has been cut off for over 10min before wiring, or else it may cause electric-shock.
- (2) It is strictly prohibited to connect power line with the output terminals U, V and W of the inverter.
- (3) The inverter itself has leakage current. To ensure the safety, inverter and motor shall be earthed safely. The grounding line shall be 3.5mm² or above copper line with its grounding resistance less than 10Ω.
- (4) The inverter has passed the withstand voltage test before leaving factory, and so user shall not carry out it to inverter.
- (5) As shown in Fig.1-3, no electromagnetic contactor and absorption capacitor or other RC absorbing device shall be provided between inverter and motor.
- (6) To provide overcurrent protection at input side and the convenience of power-off maintenance, the inverter shall be connected to power source via intermediate breaker.
- (7) Over 0.75mm² stranded wire or shielded wire shall be selected for DI and DO wiring. One end of the shielding layer shall hang in the air while the other end connected to the grounding terminal of inverter with wiring length less than 50m.

⚠ Danger

- (1) Ensure the power supply of inverter has been cut off completely, and all LED indicators of operation keyboard are off. Then wait for over 10min before carry out wiring operation.
- (2) The DC voltage between the main circuit DC bus of inverter shall fall under DC36V before carrying out the internal wiring work.
- (3) The wiring operation can only be carried out by the trained and qualified professionals with authorization.
- (4) Check with care the voltage class of inverter complies with power supply voltage before powering on, or else it may result in personal injury and device damage.

3.4 Wiring of Main Circuit Terminal

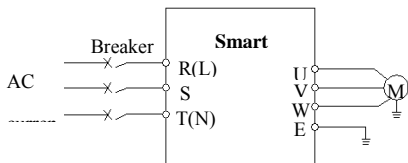

Fig.3-9 Simple Wiring of Main Circuit

3.4.1 Connection of Inverter and Optional Components

- (1) Breaking device such as isolating switch shall be installed between supply network and inverter for personal safety and forced power off in maintenance.
 - (2) The power supply circuit of inverter shall be equipped with quick fuse or breaker for overcurrent protection so as to prevent the fault range enlarging.
 - (3) AC input reactor If the power quality supplied by the network is not good, AC input reactor shall be provided can also increase the power factor at input side.
 - (4) The contactor is only used for power supply control.
 - (5) EMI filter at input side EMI filter is optional to suppress the high-frequency Conducted interference and radio-frequency interference Sent out from the power line of inverter.
 - (6) EMI filter at output side EMI filter is optional to suppress the radio- Frequency interference noise and wire leakage current generated from the output side of inverter.
 - (7) AC output reactor If the connection wire between inverter and motor exceed 50m, it is suggested to install AC output reactor to reduce Leakage current and prolong the work life of motor.
- Pay attention to the voltage drop of AC output reactor during installation. Increase the input/output voltage of inverter or decrease the rated values of motor to avoid burning motor.
- (8) Safe grounding line

Notes for grounding

- ① Use grounding cable of bigger standard section (Wire diameter standard refers to table 3-1) to ensure low grounding resistance. Due to high-frequency impedance of flat conductor is smaller than round conductor when the cross section in cable is same, flat cable

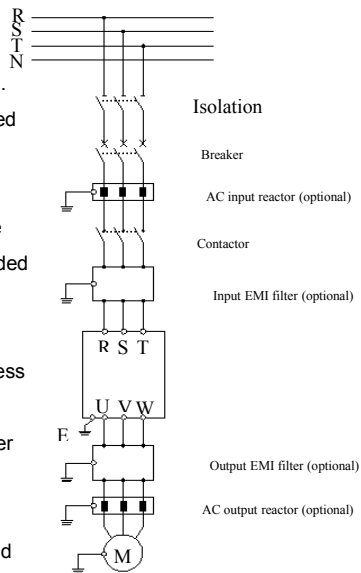

Figure 3—10 Connection of Inverter and Optional Parts

will be preferred. Grounding cable should be as short as possible and grounding point keeps close to inverter.

Table 3-1 Sectional Area of Protective Conductor

Sectional area of conductor in installation $S(\text{mm}^2)$	Min. sectional area of the corresponding grounding conductor $S(\text{mm}^2)$
$S \leq 16$	S
$16 < S \leq 35$	16
$35 < S$	$S/2$

② If 4-core cable is used, one side of 4-core cable must be grounded at inverter side, another side connected to grounding terminal of motor. If motor and inverter has its dedicated grounding electrode, the best grounding effect will be achieved.

③ If grounding terminal of each component in control system is connected, due to noise source forming by earth leakage current, other peripheral equipments outside inverter will be affected. So in same control system, inverter and weak current equipment must be grounded separately instead of connecting together, e.g. computer, sensor or audio apparatus.

④ To get low high-frequency impedance, fixed bolt in each equipment can act as high-frequency terminal connecting cabinet rear panel. Attention should be paid to remove insulation varnish of fixed point when installed.

⑤ Laying grounding cable must be away from I/O wire of noise sensitive equipment while try to shorten grounding wire.

There are three grounding methods below:

(1) Dedicated grounding pole (best), seen in Fig. 3-11. (2) Common grounding pole (available), seen in Fig.3-12.

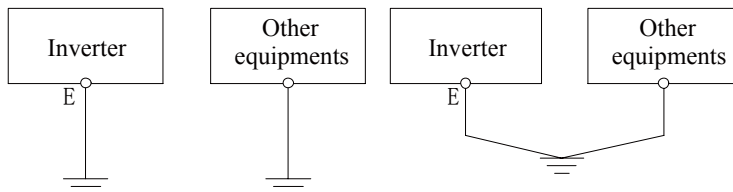

Fig.3-11 Dedicated Grounding Pole Diagram Fig.3-12 Common Grounding Pole Diagram

(3) Common grounding pole (not recommended), seen in Fig. 3-13 and 3-14.

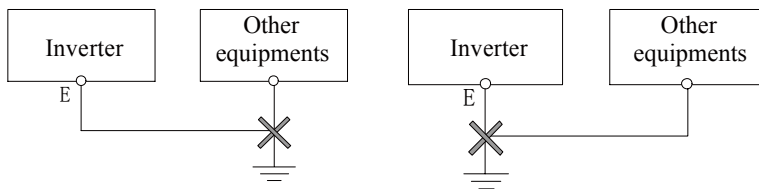

Fig.3-13 Common Grounding Pole Diagram (a) Fig.3-14 Common Grounding Pole Diagram (b)

3.4.2 Wiring of Main Circuit Terminal

(1) The input/output terminals of the main circuit are as shown in Table 3-2 below.

Main Circuit Terminal	Terminal Name	Function Description
<p>R S T E L N E</p>	R、S、T	AC power input terminal, R, S and T connects to three-phase 380V AC power. L and N connects to single-phase 220V AC power.
	E	Earthing terminal.
<p>U V W PB P</p>	U、V、W	Inverter output terminal connects to three-phase AC motor.
	P、PB	External brake resistor connection terminal

(2) Type selection of cable diameter, inlet-coil protection breaker QF or fuse is as shown in Table 3-3 below:

Model	Breaker (A)	Fuse (A)	Input wire (mm ²)	Output wire (mm ²)	Control wire (mm ²)
Smart-2S0007M	10	10	1.5	1.5	1
Smart-2S0015M	20	16	1.5	1.5	1
Smart-2S0022M	32	20	2.5	2.5	1
Smart-4T0007M	10	10	1.5	1.5	1
Smart-4T0015M	10	10	1.5	1.5	1
Smart-4T0022M	16	10	2.5	2.5	1
Smart-4T0040M	20	16	2.5	2.5	1

3.5 Wiring Diagram for Basic Running

Inverter wiring is divided into main circuit and control circuit. User can open the cover of output/input terminal. The terminals of main circuit and control circuit are visible. User must correctly connect wires as shown below.

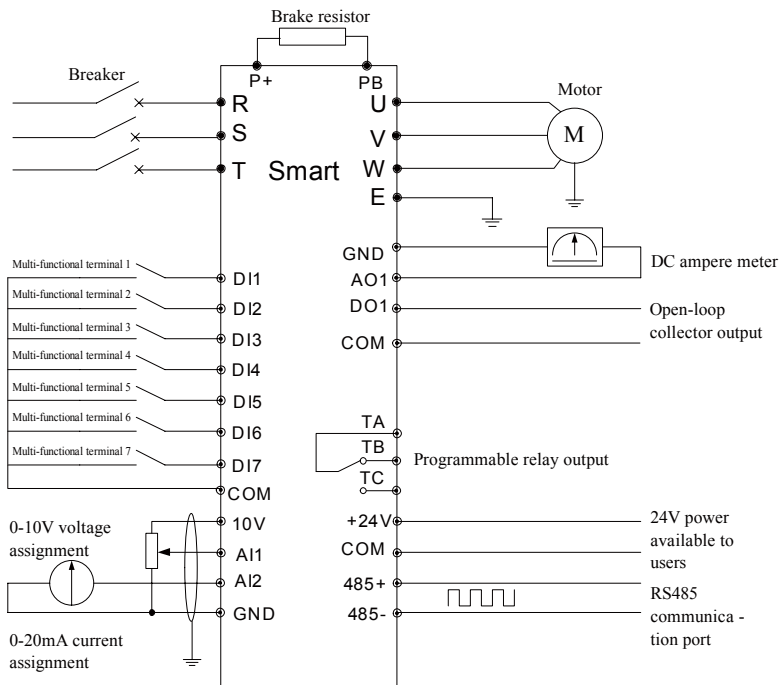

Fig. 3-15 Wiring Diagram for Basic Running

3.6 Configuration and Wiring of Control Circuit

3.6.1 The control circuit terminal CN3 is arranged below:

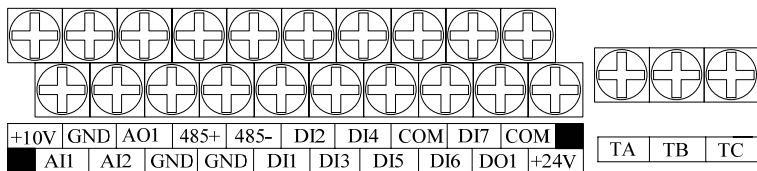

Fig. 3-16 Simple Wiring of Main Circuit

3.6.2 Functional Description of CN3 Terminal

Category	Terminal No.	Function Description	Specification
Multi-functional digital input terminal	DI1	Valid when DI(DI1、DI2、DI3、DI4、DI6、DI7) is short-circuited to COM. Functions are set by using parameter F5.00~F5.03, F5.05 and F5.06 (Common port: COM).	INPUT, 0~24V level signal, effective at low level, 50mA.
	DI2		
	DI3		
	DI4		
	DI6		
	DI7		
	DI5	Except used as common multi-functional terminal, it is programmed as high-speed pulse input port. Details refer to F5.04 functional description.	
Digital signal output terminal	DO1	Multi-functional programmable collector open-loop output 1. It is programmed as multifunction switching value output terminals (common port: COM).	OUTPUT, max. load current is no more than 50mA.
Analog input and output terminal	AI1	AI2 receiving voltage/current input is selected by jumper JP2. Input voltage is default upon factory shipment. If current is input, short-circuit jumper cap centre with V terminal. AI1 only receives voltage input. Its measuring range refers to F6.00~F6.07 functional description. (Referring ground: GND)	INPUT, range of input voltage: 0~10V (input impedance: 102KΩ), range of input current: 0~20mA (input impedance: 500Ω).
	AI2		

Category	Terminal No.	Function Description	Specification
Analog input and output terminal	AO1	Provide analog voltage/current output. Show 8 physical quantities. Output voltage/current is chosen by jumper JP1. Output voltage is default upon factory shipment, corresponding to output frequency (before slip compensation). If current is input, short-circuit jumper cap centre with I terminal. Details refer to F6.16 functional description (Reference ground: GND).	OUTPUT, 0~10V DC voltage. Output voltage at AO1 terminal is produced from PWM waveform in central processor. The size of output voltage is proportional to positive pulse width in PWM waveform.
Relay output terminal	TA	It is programmed as 15 multi-functional relay output terminals . Details refer to F5.12 terminal functional description.	TA-TB: normal close; TA-TC: normal open.
	TB		
	TC		
Power Port	+24V	24V is common power of digital input/output terminal circuit.	Max. output current 50mA
	+10V	10V is common power of analog input/output terminal circuit.	Max. output current 20mA
	COM	Reference ground of digital signal and +24V power source	Isolated from GND inside.
	GND	Reference ground of analog signal and +10V power source	Isolated from GND inside.
Communication Port	485+	RS485 signal+ terminal	Standard RS485 communication port, not isolated from GND. Please use twisted-pair cable or shielded cable.
	485-	RS485 signal-terminal	

3.6.3 Wiring of Analog Input/Output Terminal

(1) AI1 terminal receives analog voltage signal input and its wiring is seen below:

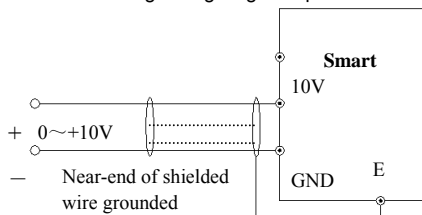

Fig.3-17 AI1 Terminal Wiring Diagram

(2) AI2 terminal receives analog voltage and current signal input, and its wiring is seen below:

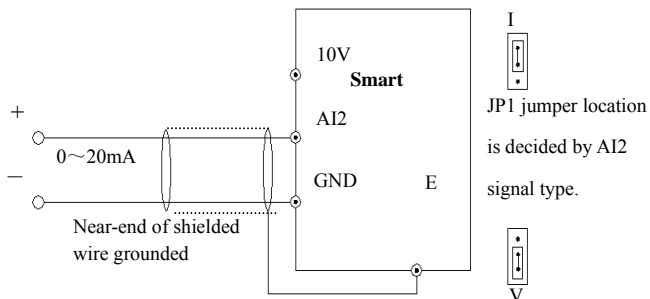

Fig.3-18 AI2 Terminal Wiring Diagram

(3) Wiring of analog output terminal AO1

Analog meter of analog output terminal AO1 can indicate many physical quantities. Terminal wiring method is seen in Fig.3-19.

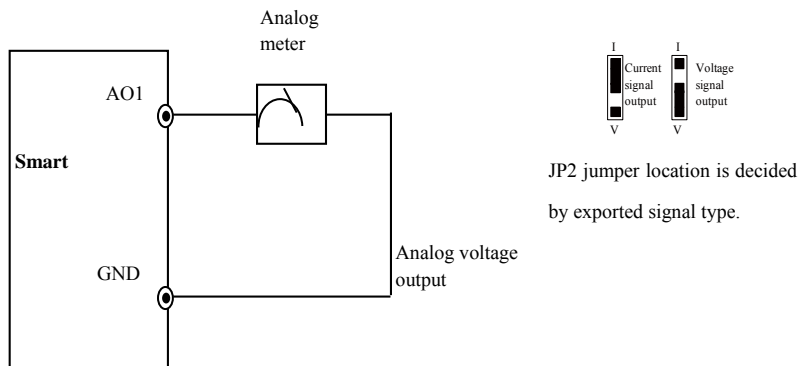

Fig.3-19 Analog Output Terminal Wiring

 **Tip:**

Analog input and output signal is easily disturbed. Must use shielded cable when wiring is made. Grounding must be sound with wiring length as short as possible.

3.6.4 Communication Terminal Wiring

Smart inverter offers standard RS485 communication port to users.

- (1) RS485 port can link remote-control keyboard with inverter. Directly link plug of remote-control keyboard to inverter RS485 communication port. Take away inverter keyboard, the inverter keyboard and remote-control keyboard can not work at same time.
- (2) Connection between inverter RS485 port and upper computer:

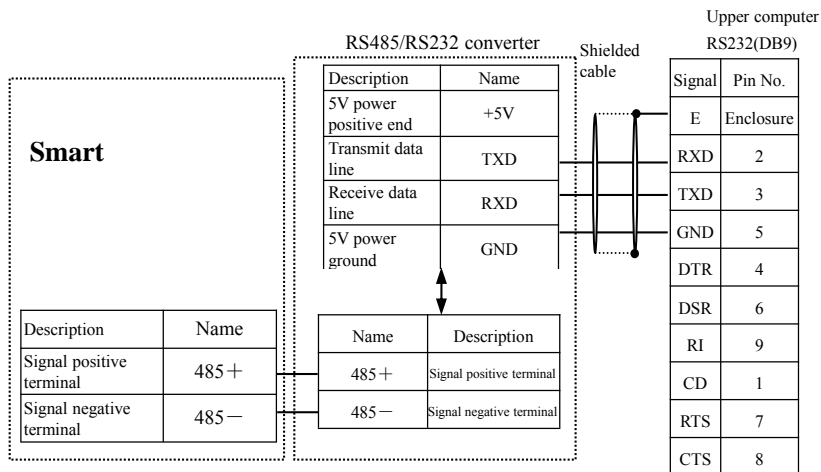

Fig.3-20 RS485—(RS485/232)—RS232 Communication Wiring

- (3) RS485 can connect multiple inverters together, which is controlled by PLC (or upper computer), seen in Fig. 3-21. One inverter acts as host and others act as slave machine, seen in Fig.3-22. With the number of inverters increasing, communication system is more easily disturbed. Wiring is recommended below:

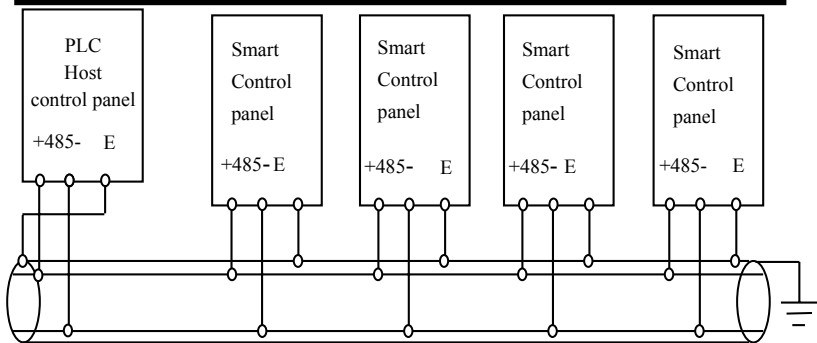

Fig.3-21 The Wiring When PLC communicate with Multiple Inverters (Inverter and Motor are grounded well)

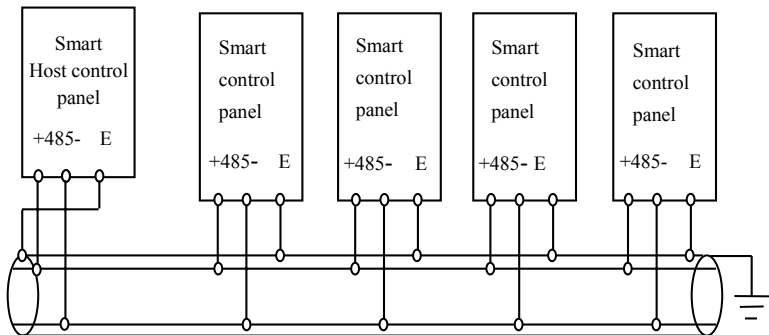

Fig.3-22 Wiring of Multiple Inverters Communicating (Inverter and motor are grounded well)

If communication does not work normally by using above wiring, the following measures can be taken :

- (1) Supply power to PLC independently (or upper computer) or isolate other power supply.
- (2) Apply magnetic ring in communication wire; reduce inverter carrier frequency.

3.7 Installation Instructions Complying with EMC Requirements

Inverter exports PWM wave so it produces electromagnetic noise when working. To reduce disturbance outside, the section will describe the EMC installation method of inverter in aspects from noise suppression, on-site wiring, grounding, current leakage and power filter.

3.71 Noise Suppression

(1) Noise Types

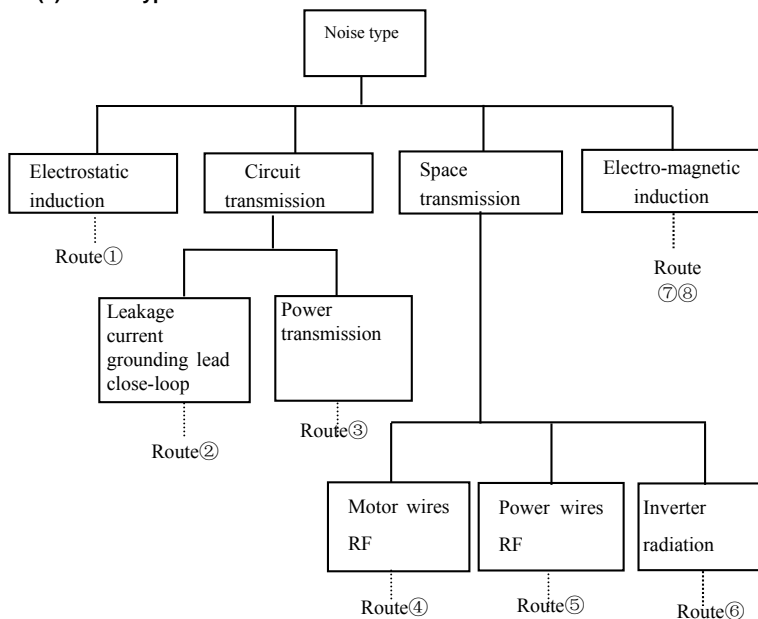

(2) Basic Countermeasure for Noise Suppression

Table 3-4 Countermeasure Table of Interference Suppression

Noise transmission route	Countermeasures to reduce impact
②	If the grounding line of peripheral equipment forms close loop together with the wiring of inverter, the grounding line of inverter will leak current, which may cause malfunction of the equipment. In this case, if the equipment is not grounded, it may decrease malfunction.
③	If the power supply of peripheral equipment shares the same system with that of inverter, the noise of inverter will transmit reverse to power line, which may interfere with other equipments in the same system. For this reason, the following suppression measures can be adopted: install electromagnetic noise filter at input terminal of inverter and isolate other equipments by standby isolation transformer or power filter.

④⑤⑥	<p>(1) The equipments and signal line easy to be interfered shall be installed away from inverter as possible. Shielded line shall be adopted for signal line with one end of shielded layer grounded, and it shall be kept away from inverter and its input/output line as possible. If the signal line shall be crossed with strong-current cable, they shall be orthogonal.</p> <p>(2) Install high-frequency noise filter (ferrite common-mode choke coil) respectively at the root parts of input and output sides of inverter to effectively suppress the radio-frequency interference of power line.</p> <p>(3) The cable line of motor shall be placed in the much thick shield such as thicker (above 2mm) pipe or buried in cement tank. The power line shall be pulled through metal pipe and the shielded line shall be grounded (motor cable shall be 4-core type cable with one grounded at inverter side and connected to motor case at the other end).</p>
①⑦⑧	<p>Avoid the parallel wiring or bundling of strong and weak current wires; install the equipment far away from inverter as possible and its wiring shall be away from the input/output wire of inverter. Signal line shall be shielded line. As for the equipment with strong electric field or strong magnetic field, attention shall be paid to its installation place relative to inverter and distance. They shall be orthogonal.</p>

3.7.2 On-site Wiring and Grounding

- (1) Wire from inverter to motor (outlet of terminal U, V and W) shall not be parallel to the power line (inlet of terminal R, S, T, or R, T) and shall be kept over 30cm away from the power line.
- (2) 3 motor lines of the inverter output terminal U, V and W shall be kept in metal pipe or metal wireway.
- (3) Control signal line shall be shielded type with the shielded wire mesh connected to metal case through cable clips on both sides, shown in Fig. 3-23:

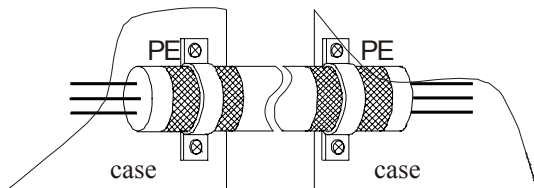

Fig. 3-23 Correct Grounding Method

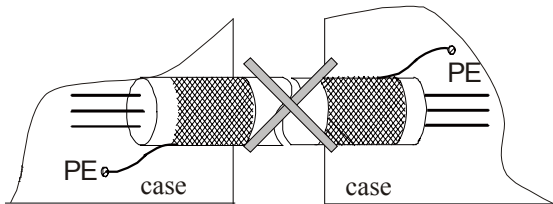

Fig. 3-24 Wrong Grounding Method

(4) PE grounding cable of inverter shall not be grounded by using the grounding line of other equipment, and shall be grounded directly with the earth.

(5) Control signal line shall not be wired in parallel and close to strong-current wire (R, S, T or R, T and U, V, W), and shall not be bundled together but to kept 20-60cm (related to strong current) away from each other. If they need to be wired by crossing, they shall be vertical to each other as shown in Fig.3-25.

(6) Weak-current grounding line of control signal and sensor and strong grounding line shall be grounded respectively and separately.

(7) It is not allowed to connect other devices at the power input terminal (R, S, T or R, T).

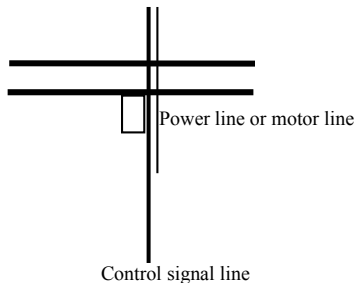

Fig. 3-25 System Wiring Requirement

3.7.3 Notes for Grounding

- ※ Disconnect inverter input power when motor is replaced.
- ※ Switch motor or power frequency power supply when inverter stops input.
- ※ To reduce electromagnetic interference, when electromagnetic contactor and relay are close to inverter, surge absorber should be mounted.
- ※ Do not connect DC input power to output terminal U,V and W.
- ※ External control line of inverter should be mounted with isolation device or shielded wire.
- ※ Except being shielded, input command signal wire should be wired

independently, far way from main circuit wire.

- ※ For carrier frequency lower than 4KHz, the max. distance between inverter and motor should be 50 m. For carrier frequency above 4KHz, the distance should be shortened. Wire must be laid inside metal tube.
- ※ When inverter is mounted with peripheral equipment(filter and electric reactor, etc), 1000V tramegger should be used to measure its insulation resistance to the ground, no less than 4 Ω ,
- ※ Do not install phase capacitor or resistance capacitor absorbing device at U, V and W terminal.
- ※ If inverter starts frequently, do not cut off electricity. Stop and start inverter by using control terminal, avoiding rectifier bridge damaged.
- ※ To avoid accident, E terminal must be grounded reliably(grounding impedance below10 Ω), or else leakage may occur.
- ※ When main circuit is wired, wire diameter selection should abide by national electrical engineering rules.

3.8 Standby Circuit

Serious stop loss or other emergency may be caused when inverter fails or trips. In this case, it is recommended using standby circuit to keep safe.

Note: Confirm and test running features of standby circuit, ensure its power frequency consistent to phase sequence of inverter.

Chapter 4 Inverter Running and Operation

4.1 Inverter Running

4.1.1 Working Status of Inverter

The SMART inverter controls actions through three command channels, such as start, stop and jog.

Operation panel

Start and stop motor using 、、 key in keyboard.

Control terminal

2-way control is formed by using any 2 multi-function DI terminals in control panel set as FWD and REV function and COM or 3-way control is formed by using any 3 multi-function DI terminals in control panel and COM.



Serial port

Start and stop inverter by using principal computer or other equipment communicating with the inverter.

Command channel is selected by setting function code F0.01.

4.1.2 Inverter frequency assignment channel

The Smart series inverter generally runs under 8 physical channels with frequency assigned, including:

- 0: keyboard analog potentiometer assignment
- 1: digital setting 1, adjust 、 key in keyboard
- 2: digital setting 2, adjust UP/DOWN terminal
3. digital setting 3, communication assignment
- 4: analog voltage signal AI1 (AI2) (0-10V) assignment
- 5: analog current signal AI2 (0-20mA) assignment
- 6: terminal pulse (0-50KHZ) assignment
- 7: combination assignment

4.1.3 Working Status of Inverter

The SMART inverter has four working statuses: stop, run, programme and alarm.

Stop : When the inverter power is initialized, if no run command input or the stop command is sent during run, the inverter will enter idle mode.

Run: When the run command received, inverter will enter run status.

Programme : Keyboard operation panel can be used to change and set the function parameters of inverter.

Fault alarm: If any fault happens to peripheral equipment or inverter itself, or there is any operation error, the inverter will send out the corresponding fault code and lock out the output.

4.1.4 Run Mode of Inverter

The SMART inverter consists of five running modes that are jog run→PID→PLC→multi-speed→common run according to priority, shown in Fig.4-1.

0: jog run

In stop status, the inverter will run by jog frequency (see functional code F1.09~F1.12) after receiving jog run command (e.g. after pressing  key in operation keyboard)

1: close-loop running

Chose the parameter P7.00 to Set PID action, frequency inverter will access close-loop running mode. Meaning the inverter will do PID adjustment according to the given quantity and feedback quantity.

2.PLC running

Set the parameter P8.00 to validate PLC function, frequency inverter will operate PLC running mode, it will run according to the pre-set running mode.

3. Multi-speed running

By the combination of multi-function terminals (1, 2, 3 functions), chose multi-speed frequency 1-7(F8.01-F8.07) to operate multi-speed running.

4: common run

The simple open-loop run mode of general inverter.

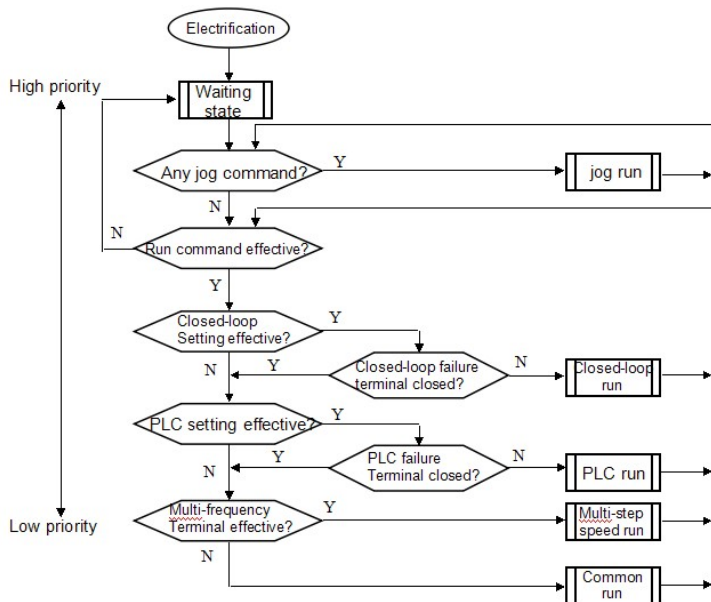

Fig.4-1 Logic Diagram of Smart Inverter Running Status

4.2 Keyboard Operation and Use









4.2.1 Keyboard Layout

Operation keyboard is main unit receiving command and showing parameters in inverter. Its external view is seen in Fig.4-1:



Fig. 4-2 Schematic Diagram of LED Operation Panel

The operation keyboard of inverter has 9 keys with their functions defined below:

Key	Name	Functions
	Shift	When data is corrected, press this key to select the digits to be changed. The digits to be changed will flash. In monitoring mode, press this key to shift monitoring parameters.
	Multi-function	It is default as JOG according to F0.15 parameter setting.
	Analog potentiometer	Used for frequency assignment. When F0.02=0, analog potentiometer is set as frequency assignment.
	Programme	Change working mode of operation panel, enter or exit from programming status.
	Up	Increase data or functional code.
	Confirm	Enter lower menu or confirm data.
	Run	Press this key to run device.
	Down	Decrease data or functional code.
	Stop/reset	In normal working, press this key to stop inverter. In fault, press this key to reset inverter and clear fault code.

4.2.2 LED Nixie tube and Indicator Lamp Description:

Indicator Lamp Function Description	Name	Function Description	Symbol
	Frequency indicator lamp	It flashes when frequency data is shown in LED.	Hz
	Current/voltage indicator lamp	Red lamp flashes when current data is shown on LED. Green lamp flashes when voltage data is shown on LED.	A/V
	Alarm indicator lamp	It flashes when inverter fails.	ALM
	Forward/reverse indicator lamp	Green lamp flashes when inverter forward runs. Green lamp flashes when inverter reversely runs.	F/R

4 8-section LED Nixie tubes, 2 unit indicator lamps and 2 status indicator lamps are arranged in operation panel, seen in Fig. 1. Nixie tube shows status parameter, function code parameter, fault alarm code, etc. 2 unit indicator lamps shows three units. 2 status indicator lamps show forward/reverse and alarm status indication, described below:

LED digital display and unit indicator lamp combination:

Combination of Indication Lamp	LED Display Meaning	Symbol
Hz+A	Motor speed	r/min
A+V	Time (sec)	s
Hz+V	Actual percentage	%
Hz+A+V	Temperature	°C

4.3 Setting Method of Common Function Code Parameter (no more than 4 bits at most)



Function code system: 17 groups of function codes: F0 ~ FF, E and d group. Each function group has several function codes. Function code is marked as function code.



group no. + function code no., for example, "F5.08" means no.8 function in the fifth group.

Menu structure in LED keyboard display unit: When function code is set through LED keyboard display unit, function group no. is level 1 menu, function code no. is level 2 menu and function code parameter is level 3 menu. Setting example of common function code (no more than 4 bits):





Example 1: increase hopping frequency 0Hz to 10.0 Hz 1 (Change F1.15 from 0.0Hz to 10.0Hz)

1) Press  to enter programming status. Nixie tube shows F0.00 and flicker bit stays at the first LED.

2) Press  to see flicker bit moves within parameter item. Do not change numbers of the 2nd and 3rd LED. Press  and keep flicker it stay at the 3rd LED.

3) Press  to change "0" to "2" in the 3rd LED. Press  and flicker bit stays at the 2nd LED. Change "0" to "1". Press  and flicking stays at unit's bit. Change "0" to "5".



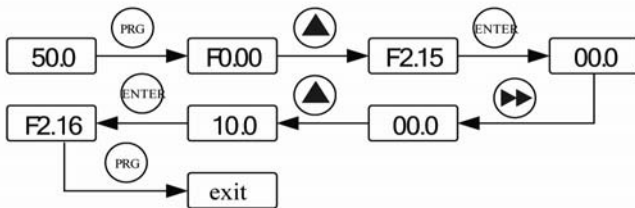

Nixie tube shows F1.15.

- 4) Press  to see corresponding parameter F1.15 (0.0) while luminous diode (Hz) corresponding to unit frequency flashes.
- 5) Press  and flicker bit stays at the third LED, press  and set 1, now it shows 10.0.
- 6) Press  to save F1.15 value and automatically show next function code (F1.16).
- 7) Press  to exit and return main interface.





Example 2: Check Monitoring Parameter Item d-04(Output Current)

Method 1:

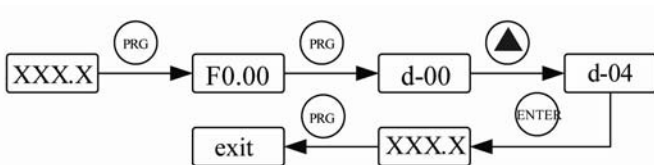
- 1) Press  to enter programming status. Nixie tube shows F0.00, press  again , Nixie tube shows d-00, and flicker bit stays at the first LED. Adjust  until d-04 is shown.
- 2) Press  to see parameter corresponding to d-04 while luminous diode (A) corresponding to unit ampere flashes.
- 3) Press  to exit programming status and return main interface.



Method 2: In particular monitoring item value interface, press  , go to d-xx, flicker bit stays at unit's bit of parameter item, adjust  or  , until d-04 is shown. Repeat 2) and 3) in method 1.

4.4 Setting Method of Special Function Code Parameter (maximal value exceeds 4 bits)

Category 1: default one decimal. Press  , and then decimal is not shown (now set thousands' digit):

Example : F0.10 (acceleration) is set as 1000.5 second by using steps:

1) Enter F0.10 setting interface by using method in example 1. Default value is 10.0. Flicker bit stays at the first LED.

2) Press  and then decimal is not shown. Show 0010 and decimal point in the first LED flashes, flicker bit stays in the forth LED (thousands' digit).

3) Press  once, to show 1010.

4) Press  twice, flicker bit stays at the 2nd LED.

5) Press  once to show 1000.

6) Press  twice, flicker bit stays at the first LED.

7) Press  five times to show 000.5, so F0.10 is 1000.5 sec.

8) Press  to save F0.10 and F0.11 shows.



9) Press  to exit programming status and return main monitoring interface.

Category 2: default no decimal is shown. Press  to hide unit's bit and show myriabit .



Example: Set F3.03 (motor rated speed) as 12345 by using steps:

1) Enter F3.03 setting interface by using method in example 1. Default value is 1400.

2) Press  , flicker bit stays at the forth LED (Note: The original unit's bit value is not shown. The first LED is tens' digit, 2nd LED is hundreds' digit, 3rd LED is thousands' digit and forth LED is myriabit. To show status difference, the decimal point in the first LED is shown).



Set 1. Press  , set the third LED (thousands' digit) as 2, set the 2nd LED (hundreds' digit) as 3. Set the first LED (tens' digit) as 4. Press  to show unit's bit (Note: The decimal point

in the first LED is not shown). Set 5.

- 3) Press  to save F3.03 and F3.04 shows.
 - 4) Press  to exit programming status and return main monitoring interface.
-



Note:

- 1) Setting of most parameters is available when inverter stops. However, in running, only some parameters are selected. Refer to Function Parameter in Chapter Five.
- 2) In case of fault, user can inquire fault. Current fault flashes, but user can not change content of displayed code.
- 3) For parameter allowing online change, after function code is shown, the user can change parameter within setting range. For those not allowing, the adding or deleting of parameter content will be invalid by pressing  or .

Chapter 5 Function Parameter List

5.1 Function Parameter List

- mean the parameter can be changed in any status
- ×—mean the parameter can not be changed in running status
- ◆—Actual test parameter that can not be changed.

Function code	Name	Setting range	Smallest unit	Factory default	Change
F0 group-basic running parameters					
F0.00	Control method setting	0: V/F control 1: Magnetic flux vector control	1	0	×
F0.01	Running command channel selection	0: Panel running command channel 1: Terminal running command channel 2: Communication running command channel	1	0	○
F0.02	Frequency assignment channel selection	0: Panel potentiometer 1: Digital assignment1, adjust▲、▼ key in operation panel 2: Digital assignment 2, terminal UP/DOWN adjust 3: Digital assignment 3, communication assignment 4: AI1analog assignment (0~10V) 5: AI2analog assignment (0~10V/0~20mA) 6: Pulse assignment ((0~50KHZ) 7: Combination assignment	1	0	○
F0.03	Frequency combination assignment method	LED unit's digit: frequency source A 0: Panel potentiometer 1: Digital assignment 1, adjust▲、▼ key in operation panel 2: Digital assignment 2, terminal UP/DOWN adjust 3: Digital assignment 3, communication assignment 4: AI1 analog assignment 5: AI2 analog assignment 6: Pulse assignment LED tens' digit: frequency source B 0: Frequency source B in idle 1: Digital assignment 1, adjust ▲、▼ key in operation panel 2: Digital assignment 2, terminal UP/DOWN adjust 3: Digital assignment 3, communication assignment 4: AI1analog assignment	1	041	○

Function code	Name	Setting range	Smallest unit	Factory default	Change
F0.03	Frequency combination assignment method	5: AI2 analog assignment 6: Pulse assignment LED hundreds' digit: combinational algorithm 0: A plus B 1: A minus B 2: A minus B (take absolute) 3: Take maximal value from A and B 4: Take minimal value from A and B LED thousands' digit: retain Note: It is valid only when F0.02=7.	1	041	○
F0.04	Digital frequency control	LED unit's digit: Power-off save 0: save 1: not save LED tens' digit: keep when shut-down 0: keep 1: not keep LED hundreds' digit: UP/DOWN negative frequency adjust 0: invalid 1: valid LED thousands' digit: retain Note: It is valid only when F0.02=1、2.	1	000	○
F0.05	Digital setting of run frequency	0.0~【F0.07】	0.1Hz	50.0	○
F0.06	Max. output frequency	MAX{50.0, 【F0.07】}~2000.0Hz	0.1Hz	50.0	×
F0.07	Upper limit frequency	MAX{0.1, 【F0.08】}~【F0.06】	0.1Hz	50.0	×
F0.08	Lower limit frequency	0.0~【F0.07】	0.1Hz	0.0	×
F0.09	Direction setting	0: forward 1: reversal 2: reversal limiting	1	0	○
F0.10	Acceleration time 1	0.1~3600.0S	0.1S	Type setting	○
F0.11	Deceleration time 1		0.1S	Type setting	○
F0.12	Setting of carrier frequency	0.4~4.0KW 6.0KHz 1.0~12.0KHz 5.5~7.5KW 5.5KHz 1.0~12.0KHz Note: Upper limit of carrier Frequency can exceed12.0KHz only when V/F control and manual torque are selected and dead-time compensation is invalid.	0.1KHz	Type setting	○

Function code	Name	Setting range	Smallest unit	Factory default	Change
F0.13	Parameter initialization	0: no operation 1: All parameters reset to factory setting except for 【F.C.05】 and 【FA.16】~ 【FA.18】. 2: All parameters reset to factory setting except for 【FC.05】 and 【FA.16】~ 【FA.18】 and motor parameters. 3: clear fault record	1	0	×
F0.14	Parameter write-protection	0: Write-protection closes. 1: Only allow to change frequency setting parameters 【F0.02】~ 【F0.08】 2: Prohibit changing all parameters. Note: The above limitations are valid to this parameter and FC.05 parameters.	1	0	○
F0.15	Key setting	LED unit's digit: M-FUNC key setting 0: JOG 1: shift between forward and reverse run 2: clear frequency setting of ▲/▼ key 3: reverse run (RUN key defaults forward run) LED tens' digit: STOP key 0: invalid when terminal runs but valid when communication runs. 1: invalid when terminal runs but valid when communication runs. 2: invalid 3: valid LED hundreds' digit: retain LED thousands' digit: retain	1	30	×
F1 group- assist run parameters					
F1.00	Start/stop method and DC brake mode	LED unit's digit: start method 0: start from start frequency 1: speed tracking start LED tens' digit: stop method 0: deceleration stop 1: free stop LED hundreds' digit: start method in case of power failure or abnormality 0: invalid 1: start from start frequency 2: speed tracking start LED hundreds' digit: DC brake mode 0: current closed loop 1: voltage opened loop	1	0000	×
F1.01	Starting frequency	0.0~50.0Hz	0.1Hz	1.0	○

Smart Series Frequency Inverter User Guide

Function code	Name	Setting range	Smallest unit	Factory default	Change
F1.02	Hold time of starting frequency	0.0~10.0s	0.1s	0.0	○
F1.03	DC brake current/voltage for starting	0.0~150.0%×motor rated current/0.0~30.0%×motor rated voltage	0.1%	0.0%	○
F1.04	DC brake time for starting	0.0~30.0s	0.1s	0.0	○
F1.05	DC brake starting frequency for stopping	0.0~upper limit frequency	0.1Hz	0.0	○
F1.06	DC brake current/voltage for stopping	0.0~150.0%×motor rated current/0.0~30.0%×motor rated voltage	0.1%	0.0%	○
F1.07	DC brake time for stopping	0.0~30.0s	0.1s	0.0	×
F1.08	DC brake waiting time for stopping	0.00~100.00s	0.01s	0.10	×
F1.09	Forward jog frequency setting	0.0~upper limit frequency	0.1Hz	10.0	○
F1.10	Reverse jog frequency setting	0.0~upper limit frequency	0.1Hz	10.0	○
F1.11	Jog acceleration time	0.1~3600.0S (Unit is selected by 【FC.04】 , default as sec.)	0.1S	10.0	○
F1.12	Jog deceleration time		0.1S	10.0	○
F1.13	Acceleration time 2		0.1S	10.0	○
F1.14	Deceleration time 2		0.1S	10.0	○
F1.15	Hopping frequency 1	0.0~upper limit frequency	0.1Hz	0.0	○
F1.16	Hopping range	0.0~10.0Hz	0.1Hz	0.0	○
F1.17	Dead time of forward and reverse rotation	0.0~10.0s	0.1s	0.0	×
F1.18	Treatment when lower limit frequency is reached.	0: 0-speed run 1: run by the lower limit frequency	1	0	×
F2 group-VF control parameter					
F2.00	V/F curve setting	0: linear curve 1: reduced torque curve1 (1.5 power) 2: reduced torque curve2 (2.0 power) 3: multi-point VF curve	1	0	×
F2.01	Torque up quantity	0.0 means automatic increase (simple magnetic flux control), 0.1~30.0% means manual up quantity	0.1%	0.0%	○
F2.02	Torque up cut-off frequency	0.0~50.0Hz	0.1Hz	50.0	×
F2.03	V/F frequency value F1	0.1~frequency value F2	0.1Hz	12.5	×
F2.04	V/F voltage value V1	0.0~voltage value V2	0.1%	25.0%	×
F2.05	V/F frequency value F2	frequency value F1~frequency value F3	0.1Hz	25.0	×

Function code	Name	Setting range	Smallest unit	Factory default	Change
F2.06	V/F voltage value V2	voltage valueV1~voltage valueV3	0.1%	50.0%	×
F2.07	V/F frequency value F3	frequency value F3~motor rated frequency F3.04	0.1Hz	37.5	×
F2.08	V/F voltage valueV3	voltage value V3~100.0%*Uoute (motor rated voltage F3.01)	0.1%	75.0%	×
F3 group-Motor parameters					
F3.00	Inverter load type	0: M model(constant torque) 1: FP model(fan water pump type)	1	0	×
F3.01	Motor rated voltage	380V: 0~500V 220V: 0~250V	1V	380 220	×
F3.02	Motor rated current	0.1~3000.0A	0.1A	Type setting	×
F3.03	Rated speed of motor	0~60000RPM	1RPM	Type setting	×
F3.04	Motor rated frequency	1.0~2000.0Hz	0.1Hz	50.0Hz	×
F3.05	No-load current of motor	0.1~ F3.02	0.1A	Type setting	×
F3.06	Resistance of motor stator	0.001~20.000Ω	0.001Ω	Type setting	×
F3.07	Motor parameter tuning	0: no action 1: quiet tuning(measure stator resistance) 2: complete tuning(measure stator resistance and no-load current)	1	0	×
F4 group- Performance optimization parameters					
F4.00	PWM mode	LED unit's digit: dead-time compensation selection 0: invalid 1: valid LED tens 'digit: overmodulation selection 0: invalid 1: valid LED hundreds' digit: carrier mode selection 0: PWM mode 1 (routine) 1: PWM mode 2 (full-frequency 7 sections) LED thousands' digit: low-frequency carrier adjustment 0: invalid 1: valid	1	1001	×
F4.01	Acceleration current limit coefficient	0: close, 1~255	1	10	×
F4.02	Constant speed current limit coefficient	0: close, 1~255	1	0	×
F4.03	Deceleration voltage limit coefficient	0: close, 1~255	1	10	×
F4.04	Slip frequency compensation	0~200%*motor rated slip frequency (Default as 100% factory value in magnetic flux vector mode)	1%	0%/ 100%	○

Function code	Name	Setting range	Smallest unit	Factory default	Change
F4.05	slip compensation filter factor	0~255	1	5	○
F4.06	Magnetic flux proportional gain	0.01~10.00	0.01	1.00	×
F4.07	Magnetic flux integration time	0.01~10.00S	0.01S	1.00	×
F5 group-Switching value input and output					
F5.00	Function of input terminal DI1	0: control terminal in idle 1: multi-speed selection S1 2: multi-speed selection S2 3: multi-speed selection S3	1	12	×
F5.01	Function of input terminal DI2	4: ACC/DEC time selection 5: ACC/DEC inhibit command 6: running command channel is forced as terminal	1	13	×
F5.02	Function of input terminal DI3	7: running command channel is forced as communication 8: running command channel selection S1 9: running command channel selection S2	1	17	×
F5.03	Function of input terminal DI4	10: forward jog control 11: reverse jog control 12: forward control (FWD) 13: reverse control (REV)	1	18	×
F5.04	Function of input terminal DI5	14: 3-wire run control 15: free stop control 16: DC brake command for stopping 17: external stop signal input (STOP) 18: external reset signal input (RST)	1	24	×
F5.05	Function of input terminal DI6	19: external fault normally open input 20: frequency up command (UP) 21: frequency down command (DOWN) 22: clear UP/DOWN frequency	1	0	×
F5.06	Function of input terminal DI7	23: frequency source switches to AI1 setting 24: pulse frequency input (only valid for DI5) 25: counter clear signal 26: counter trigger signal 27: timer clear signal 28: timer trigger signal 29~31: retain	1	0	×
F5.07	FWD/REV terminal control mode	0: 2-wire control mode1 1: 2-wire control mode2 2: 3-wire control mode1 3: 3-wire control mode2	1	0	×
F5.08	Selection of terminal function test when power on	0: invalid terminal run command when power on 1: valid terminal run command when power on	1	0	×

Function code	Name	Setting range	Smallest unit	Factory default	Change
F5.09	UP/DOWN terminal change rate	0.1Hz~99.9Hz/S	0.1Hz/S	1.0	○
F5.10	Digital input terminal filter times	1~10	1	2	○
F5.11	Setting of output terminal DO1 in open collector	0: indicate the inverter is running 1: indicate the inverter runs at zero speed 2: Inverter is ready for running	1	0	○
F5.12	Setting of output terminal R1 in programmable relay	3: frequency/speed reach signal (FAR) 4: detection signal of frequency/speed level (FDT) 5: external fault shut-down 6: output frequency reaches upper limit 7: output frequency reaches lower limit 8: inverter fault 9: indicate running at simple PLC stage is complete. 10: indicate running at PLC cycle is complete. 11: timer overflow signal 12: counter detection signal 13: counter reset signal 14: inverter overload pre-alarm 15: over-torque indication 16: assist motor 17: PID feedback breaks to send alarm 18: 485 communication failure to send alarm 19: under overcurrent limit action 20: under overvoltage limit action 21: hibernation	1	8	○
F5.13	Detection amplitude when frequency up to FAR	0.0Hz~15.0Hz	0.1Hz	5.0	○
F5.14	FDT level setting	0.0Hz~【F0.07】	0.1Hz	10.0	○
F5.15	FDT 1 lagged value	0.0~30.0Hz	0.1Hz	1.0	○
F5.16	Reset value setting of counter	【F5.17】~65535	1	1	○
F5.17	Detection value setting of counter	0~【F5.16】	1	1	○
F5.18	Time setting	0~65535S	1S	0	○
F5.19	Inverter overload pre-alarm level	120~150%	1%	120%	○
F5.20	Inverter overload pre-alarm delay	0.0~15.0s	0.1s	5.0	×
F5.21	R1 close delay	0.0~260.0s	0.1	0.0	×
F5.22	R1 break delay	0.0~260.0s	0.1	0.0	×

Function code	Name	Setting range	Smallest unit	Factory default	Change
F6 group-analog input and output and pulse input parameter					
F6.00	AI1 lower-limit voltage	0.00 ~ 【F6.01】	0.01V	0.00	○
F6.01	AI1 upper-limit voltage	【F6.00】 ~ 10.00V	0.01V	10.00	○
F6.02	Setting corresponding to AI1 lower limit	-100.0% ~ 100.0%	0.1%	0.0%	○
F6.03	Setting corresponding to AI1 upper limit	-100.0% ~ 100.0%	0.1%	100.0%	○
F6.04	AI2 lower-limit value	0.00 ~ 【F6.05】	0.01V	0.00	○
F6.05	AI2 upper-limit voltage	【F6.04】 ~ 10.00V	0.01V	10.00	○
F6.06	Setting corresponding to AI2 lower limit	-100.0% ~ 100.0%	0.1%	0.0%	○
F6.07	Setting corresponding to AI2 upper limit	-100.0% ~ 100.0%	0.1%	100.0%	○
F6.08	Outer pulse input lower-limit frequency	0.00 ~ 【F6.09】	0.01KHz	0.00	○
F6.09	Outer pulse input upper limit frequency	【F6.08】 ~ 50.00KHz	0.01KHz	20.00	○
F6.10	Setting corresponding to outer pulse lower limit	-100.0% ~ 100.0%	0.1%	0.0%	○
F6.11	Setting corresponding to outer pulse upper limit	-100.0% ~ 100.0%	0.1%	100.0%	○
F6.12	Analog input signal filter time constant	0.1 ~ 5.0s	0.1s	0.1	○
F6.13	Analog input anti-shake deviation limit	0.00 ~ 0.10V	0.01V	0.00	○
F6.14	Zero frequency threshold	0.0 ~ 50.0Hz	0.1Hz	0.0	×
F6.15	Zero frequency return difference	0.0 ~ 50.0Hz	0.1Hz	0.0	×
F6.16	Function selection of AO analog output terminal	LED unit's digit: AO1 selection 0: output frequency 1: set frequency 2: output current 3: motor speed 4: output voltage 5: bus voltage 6: AI1 7: AI2 8: external input pulse frequency LED tens' digit: retain LED hundreds' digit: retain	1	200	○

Function code	Name	Setting range	Smallest unit	Factory default	Change
		0~8 refers to LED unit's digit selection. LED thousands' digit: retain			
F6.17	Selection of AO analog output range	LED unit's digit: set AO1 range 0: 0~10V or 0~20mA 1: 2~10V or 4~20mA LED tens' digit, hundreds' digit and hundreds' digit: retain	1	000	○
F6.18	AO1 gain setting	0.0%~100.0%	0.1%	100.0%	○
F7 group- Process PID parameters					
F7.00	PID function setting 1	LED unit's digit: PID control 0: invalid 1: valid LED tens' digit: PID modulating features 0: positive effect 1: negative effect LED hundreds' digit: retain LED thousands' digit: stop method when PID sleeps 0: deceleration stop 1: free stop	1	0000	×
F7.01	PID function setting 2	LED unit's digit: PID assignment quantity input channel 0: panel potentiometer 1: digital setting 2: AI1 3: AI2 4: outer pulse 5: AI1+AI2 6: AI1-AI2 7: MIN (AI1,AI2) 8: MAX (AI1,AI2) LED tens' digit: PID feedback quantity input channel 0: AI1 1: AI2 2: terminal pulse LED hundreds' digit: PID self-adaptive model (retain) 0: invalid 1: valid LED thousands' digit: PID hibernation method 0: It hibernates when feedback pressure is more than or less than sleep threshold (retain) 1: It hibernates when feedback pressure and output frequency are stable.	1	1000	×

Function code	Name	Setting range	Smallest unit	Factory default	Change
F7.02	Assignment quantity digital setting	0.0~100.0%	0.1%	0.0	○
F7.03	Feedback channel gain	0.01~10.00	0.01	1.00	○
F7.04	Proportional gain P	0.01~5.00	0.01	1.00	○
F7.05	Integral time Ti	0.0: no integral 0.1~50.0s	0.1s	1.0	○
F7.06	Differential time Td	0.0: no differential 0.1~10.0s	0.1s	0.0	○
F7.07	Sampling cycle T	0.0: automatic 0.1~10.0s	0.1s	0.0	○
F7.08	Deviation limit	0.0~20.0%	0.1%	0.0	○
F7.09	Close-loop predetermined frequency	0.0~upper limit frequency	0.1Hz	0.0	○
F7.10	Predetermined frequency holding time	0.0~1000.0(Unit is set by [FC.04], default is sec).	0.1	0.0	×
F7.11	Deviation between feedback and setting pressure when entering sleep	0.0~50.0%	0.1%	5.0	○
F7.12	Wake threshold	0.0~100.0%	0.1%	0.0	○
F7.13	Sleep delay time	1.0~1000.0(Unit is set by [FC.04], default is sec).	0.1	100.0	○
F7.14	Wake delay time	1.0~1000.0(Unit is set by [FC.04], default is sec)	0.1	1.0	○
F8 group- Programmable Running Parameter					
F8.00	Programmable running control (simple PLC running)	LED unit's digit: PLC control 0: invalid 1: valid LED tens' digit: running method selection 0: single cycle 1: continuous cycle 2: maintain final value after single cycle LED hundreds' digit: start method 0: start from the first stage 1: start from stop (fault) stage 2: start from stop (fault) stage and frequency LED thousands' digit: power-down save selection 0: not save 1: save	1	0000	×
F8.01	Multi-speed frequency1	-upper limit frequency~upper limit frequency	0.1Hz	5.0	○
F8.02	Multi-speed frequency2	-upper limit frequency~upper limit frequency	0.1Hz	10.0	○
F8.03	Multi-speed frequency3	-upper limit frequency~upper limit frequency	0.1Hz	15.0	○
F8.04	Multi-speed frequency4	-upper limit frequency~upper limit frequency	0.1Hz	20.0	○
F8.05	Multi-speed frequency5	-upper limit frequency~upper limit frequency	0.1Hz	25.0	○

Function code	Name	Setting range	Smallest unit	Factory default	Change
F8.06	Multi-speed frequency6	-upper limit frequency~upper limit frequency	0.1Hz	37.5	○
F8.07	Multi-speed frequency7	-upper limit frequency~upper limit frequency	0.1Hz	50.0	○
F8.08	Running time at stage 1	0.0~1000.0(Unit is set by [FC.04], default is sec).	0.1	10.0	○
F8.09	Running time at stage 2	0.0~1000.0(Unit is set by [FC.04], default is sec).	0.1	10.0	○
F8.10	Running time at stage 3	0.0~1000.0(Unit is set by [FC.04], default is sec).	0.1	10.0	○
F8.11	Running time at stage 4	0.0~1000.0(Unit is set by [FC.04], default is sec).	0.1	10.0	○
F8.12	Running time at stage 5	0.0~1000.0(Unit is set by [FC.04], default is sec).	0.1	10.0	○
F8.13	Running time at stage 6	0.0~1000.0(Unit is set by [FC.04], default is sec).	0.1	10.0	○
F8.14	Running time at stage 7	0.0~1000.0(Unit is set by [FC.04], default is sec).	0.1	10.0	○
F8.15	Stage ACC/DEC time selection 1	LED unit's digit: ACC/DEC time at stage1 0~1 LED tens' digit: ACC/DEC time at stage 2 0~1 LED hundreds' digit: ACC/DEC time at stage 3 0~1 LED thousands' digit: ACC/DEC at stage 4 0~1	0	0000	○
F8.16	Stage ACC/DEC time selection 2	LED unit's digit: ACC/DEC time at stage 5 0~1 LED tens' digit: ACC/DEC time at stage 6 0~1 LED hundreds' digit: ACC/DEC time at stage 7 0~1 LED thousands' digit: retain	0	000	○
F9 group-Protection parameter					
F9.00	Protection Setting	LED unit's digit: motor overload protection selection 0: invalid 1: valid LED tens' digit: PID feedback disconnection protection 0: invalid 1: protection action and free stop 2: alarm and maintain running at frequency of disconnection 3: alarm and decelerate till zero speed LED hundreds' digit: 485 communication failure treatment 0: protection action and free stop 1: alarm and maintain current running 2: alarm and stop	0	1001	×

Function code	Name	Setting range	Smallest unit	Factory default	Change
		LED thousands' digit; input and output phase failure selection 0: invalid 1: input is valid and output is prohibited 2 input is invalid and output is valid 3: valid			
F9.01	Motor overload protection coefficient	30%~110%	1%	100%	×
F9.02	Under-voltage protection level	180~280/300~480V	1V	200/380	×
F9.03	Overvoltage limiting level	350~380/660~780V	1V	380/740	×
F9.04	Current limiting level	100%~220%	1%	Type setting	×
F9.05	Speed tracking current limiting level	100%~220%	1%	Type setting	×
F9.06	Feedback disconnection detection value	0.0~100.0%	0.1%	0.0%	×
F9.07	Feedback disconnection detection time	0.1~1000.0(Unit is set by [FC.04], default is sec).	0.1	10.0	×
F9.08	Output phase failure and current imbalance detection threshold	10%~100%×inverter rated current	1%	50%	×
F9.09	Output current imbalance detection coefficient	1.00~10.00, 1.00: it is invalid	0.01	1.00	×
FA group- Supplementary function parameter					
FA.00	Energy consumption brake starting voltage	340~380/660~760V	1V	360/700	○
FA.01	Energy consumption brake action ratio	10~100%	1%	100%	○
FA.02	Cooling fan control	0: automatic control mode 1: keep running when being energized	1	0	○
FA.03	Fault automatic reset times	0 (invalid), 1~9, 10 (time is limitless)	1	0	×
FA.04	Fault automatic reset interval	0.5~25.0s	0.1s	3.0	×
FA.05	Waiting time of restart upon power failure	0.0~25.0s	0.1s	0.0	×

Function code	Name	Setting range	Smallest unit	Factory default	Change
FA.06	Overtorque check action	0: overtorque check action invalid 1: Only test during constant speed running. Continue output after overtorque is tested. 2: Only test during constant speed running. Stop after overtorque is tested. 3: Only test during constant speed running or deceleration running. Continue output after overtorque is tested. 4: Only test during constant speed running or deceleration running. Stop output after overtorque is tested.	1	0	×
FA.07	Overtorque check value	0~200%	1%	150%	×
FA.08	Overtorque check time	0.0~10.0s	0.1s	0.0	×
FA.09	Energy saving control function	0~16 0: invalid	1	0	○
FA.10	Magnetic flux braking function	0~10 0: invalid	1	0	×
FA.11	Frequency drop rate upon no instantaneous stop	0.1~100.0Hz/S 0.0: invalid	0.1Hz/S	0.0	×
FA.12	AVR function	0: invalid 1: valid in whole course 2: only invalid for deceleration	1	2	×
FA.13	Speed tracking start waiting time	0.00~100.00s	0.01s	1.00	×
FA.14	Count and timing mode	LED unit's digit: treatment of reaching count 0: single week count, stop output 1: single week count, continue output 2: cycle count, stop output 3: cycle count, continue output LED tens' digit: retain LED hundreds' digit: treatment of reaching timing 0: single week timing, stop output 1: single week timing, continue output 2: cycle timing, stop output 3: cycle timing, continue output LED thousands' digit: retain	—	103	×
FA.15	Retain	—	—	0	◆
FA.16	Running limiting function password	0~65535	1	0	○

Function code	Name	Setting range	Smallest unit	Factory default	Change
FA.17	Running limiting function selection	0: invalid 1: valid	1	0	○
FA.18	Running limiting time	0~65535(h)	1	0	○
FB group-Communication Parameter					
FB.00	Local machine address	0~247 0 is broadcast address	1	1	×
FB.01	MODBUS communication configuration	LED unit's digit: protocol selection 0: RTU 1: retain LED tens' digit: baud rate selection 0: 4800BPS 1: 9600BPS 2: 19200BPS 3: 38400BPS LED hundreds' digit: data format 0: no check 1: even check 2: odd check LED thousands' digit: communication response method 0: normally respond 1: only respond slave machine's address 2: not respond	1	0120	×
FB.02	Communication timeout check time	0.0 (invalid), 0.1~100.0s	0.1s	10.0	×
FB.03	Local machine answer delay	0~200ms	1ms	5	×
FB.04	Proportional correlation coefficient	0.01~10.00	0.01	1.00	×
FC group- Monitoring and Display Parameters					
FC.00	Running monitoring parameter item selection	0~20	1	0	○
FC.01	Stop monitoring parameter item selection	0~20	1	1	○
FC.02	Motor speed indication coefficient	0.01~10.00	0.01	1.00	○
FC.03	Close-loop indication coefficient	0.01~10.00	0.01	1.00	○
FC.04	Time unit selection	LED unit's digit: process PID time unit LED tens' digit: simple PLC time unit LED hundreds' digit: routine ACC/DEC time unit LED thousands' digit: retain 0: second 1: minute	1	000	×

Function code	Name	Setting range	Smallest unit	Factory default	Change
FC.05	User password	0~65535 (0~9invalid)	1	0	○
FC.06	Inverter power specification	0.10~655.35KW	0.01KW	Type setting	◆
FC.07	Main controller software version	1.00~99.99	0.01	1.00	◆
FD group-Monitoring parameter					
d-00	Output frequency(Hz)	0.0~2000.0Hz	0.1Hz	0.0	◆
d-01	Setting frequency(Hz)	0.0~2000.0Hz	0.1Hz	0.0	◆
d-02	Output voltage(V)	0~999V	1V	0	◆
d-03	Bus voltage(V)	0~999V	1V	0	◆
d-04	Output current(A)	0.0~6553.5A	0.1A	0.0	◆
d-05	Motor speed (RPM)	0~6000RPM	1RPM	0	◆
d-06	Inverter status	0~FFFFH BIT0: run/stop BIT1: reverse/forward BIT2: jog BIT3: DC braking BIT4: energy consumption braking BIT5: overvoltage limiting BIT6: constant-speed underlocking BIT7: overcurrent limiting BIT 8~9 running status: 00-zero speed/ 01-ACC/10-DEC/11-constant speed BIT10: overload pre-alarm BIT11: motor tuning BIT12~13 running command channel: 00-panel/01-terminal/10-communication BIT14~15 bus voltage status: 00-normal/01-low-voltage protection/10-overpressure protection	1	0	◆
d-07	PID setting value(%)	0.0~100.0%	0.1%	0.0	◆
d-08	PID feedback value(%)	0.0~100.0%	0.1%	0.0	◆

Function code	Name	Setting range	Smallest unit	Factory default	Change
d-09	Analog input AI1(V)	0.00~10.00V	0.01V	0.00	◆
d-10	Analog input AI2(V/mA)	0.00~10.00V/0~20mA	0.01V	0.00	◆
d-11	Analog output AO1(V/mA)	0.00~10.00V/0~20mA	0.01V	0.00	◆
d-12	Pulse input frequency (KHz)	0.00~50.00KHz	0.01KHz	0.00	◆
d-13	Input terminal status	0~7FH	1	0	◆
d-14	Output terminal status	0~3H	1	0	◆
d-15	Module temperature (°C)	0.0~132.3°C	0.1°C	0.0	◆
d-16	Current count value	0~65535	1	0	◆
d-17	Current timing value(S)	0~65535S	1S	0	◆
d-18	Analog outputAO2(V/mA)	0.00~10.00V	0.01V	0.00	◆
d-19	Current length(KM)	0.000~65.535KM	0.001KM	0.000	◆
d-20	Retain	—	—	0	◆
d-21	Third fault code	0~24	1	0	◆
d-22	Second fault code	0~24	1	0	◆
d-23	Latest fault code	0~24	1	0	◆
d-24	Inverter status in last two faults	0~FFFFH	1	0	◆
d-25	Output frequency in last two faults (Hz)	0.0~2000.0Hz	0.1Hz	0.0	◆
d-26	Output current in last two faults (A)	0.0~6553.5A	0.1A	0.0	◆
d-27	Bus voltage in last two faults (V)	—	1V	0	◆
d-28	Module temperature in last two faults (°C)	0.0~132.3°C	0.1°C	0.0	◆
d-29	Inverter status in latest fault	0~FFFFH	1	0	◆
d-30	Output frequency in latest fault (Hz)	0.0~2000.0Hz	0.1Hz	0.0	◆
d-31	Output current in latest fault (A)	0.0~6553.5A	0.1A	0.0	◆
d-32	Bus voltage in latest fault (V)	—	1V	0	◆
d-33	Module temperature in latest fault (°C)	0.0~132.3°C	0.1°C	0.0	◆

Chapter 6 Detailed Description of Parameter Use

6.1 F0 Group-Basic Running Parameters

F0.00	Control method selection	
	0~1	0

0: V/F control

It is selected when more than one motor is driven by one inverter, motor parameter self-learning is wrongly made or controlled motor parameters can not be obtained in other ways.

1: magnetic flux vector control

It can greatly increase torque response of controlling motor in full frequency, enhance the torque output ability of motor under low frequency, suitable to situation with requirements on starting torque (e.g. drawbench, ball mill, etc).



Special prompt:

This inverter defaults that: VF control+ automatic torque lifting mode. In essence, it is a simple magnetic flux control. When motor matches inverter power, torque control performance will surpass general V/F control technology. So, ensure inverter matches motor power. If mismatched (inverter capacity is smaller), motor parameter must be correctly set (Better if tune motor parameter after setting). Or else, inverter may work abnormally. Automatic torque lifting is not recommended when multiple motors are driven by one inverter. User must set F2.01 properly. If not, inverter may work abnormally.

Correctly set motor parameter in magnetic flux vector control mode. Start motor parameter tuning to accurately measure motor inner parameter. By this, vector control will perform excellently.

F0.01	Running command channel selection	
	0~2	0

It selects physical channel receiving stop and start command.

0: operation panel running command channel

Use 、、 key to control.

1: terminal running command channel

Use defined multi-functional terminal FWD, REV, JOG FWD and JOG REV to control.

2: communication running command channel



Upper computer controls through communication mode.



F0.02	Frequency assignment channel selection	
	0~7	0

It selects assignment method of inverter running frequency.

0: keyboard potentiometer

Keyboard potentiometer adjusts running frequency. The adjusting range is 0~max. output frequency [F0.06].

1: Digital assignment 1(adjust  and  key)

Running frequency is obtained by plus F0.05 and panel frequency increment. The increment is adjusted by  and , saved in EEPROM upon power-down. (If not to save this frequency, it can set $F0.04=x1$, x is 0 or 1).

2: Digital assignment 2 (UP/DOWN terminal adjustment)

Change running frequency by using UP/DOWN terminal. When Up and COM are closed, frequency will increase. When DOWN and COM terminal are closed, frequency will drop. When UP/DOWN terminal and COM are closed or disconnected at same time, frequency will maintain unchanged. If to set frequency power-down saving, the changed frequency will be saved in EEPROM after power-down. The rate of UP/DOWN terminal changing running frequency can be set by F5.09.

3: Digital assignment 3(communication setting)

RS485 communication port receives frequency command of upper computer to set running frequency.

4: AI1analog assignment (0~10V)

Frequency is set by AI1 terminal analog quantity. Analog quantity range: 0~10V. Refer to F6.00~F6.03 definition.

5: AI2analog assignment (0~10V/0~20mA)

Frequency is set by AI2 terminal analog quantity. Analog quantity range: 0~10V/0~20mA. Refer to F6.04~F6.07definition.

6: Pulse assignment (0~50KHZ)

Frequency is set by terminal pulse frequency (only input by DI5. See F5.04 definition). Specification of input pulse signal: collector open loop output, voltage range 15~30V; frequency range 0~50.0kHz. Refer to F6.08~F6.11 definition.

7: Combination assignment

Running frequency is set by linear combination of each frequency assignment channel. Particular combination way refers to F0.03 function description.

F0.03	Frequency combination assignment method	
	000~466	041

LED unit's digit: first frequency source A

- 0: keyboard potentiometer
- 1: Digital assignment 1
- 2: Digital assignment 2
- 3: Digital assignment 3
- 4: AI1 analog assignment
- 5: AI2 analog assignment
- 6: pulse assignment

LED tens' digit: second frequency source B

- 0: frequency source B in idle
- 1: Digital assignment 1
- 2: Digital assignment 2
- 3: Digital assignment 3
- 4: AI1analog assignment
- 5: AI2analog assignment
- 6: pulse assignment

LED hundreds' digit: combination algorithm rules

- 0: A+B

The sum of frequency source A and frequency source B is assigned as running frequency.

- 1: A-B

Frequency source A minus frequency source B is assigned as running frequency. If negative, it means reverse running.

- 2: take A-B absolute

Absolute obtained from frequency source A minus frequency source B is assigned as running frequency.

- 3: take bigger one

Take maximal value of frequency source A and B as running frequency.

- 4: take smaller one

Take minimal value of frequency source A and B as running frequency.

Tip:

When frequency combination assignment is selected, PID assignment, PLC assignment and multi-speed assignment should overlap with frequency A and B by priority. It is ordered as: PID control → simple PLC → multi-speed → frequency source F0.02 selection. PID control is the highest level. Frequency source F0.02 is the lowest.

F0.04	Digital frequency control	
	000~111	000

LED unit's digit: save upon power-down

0: save

When inverter is energized, panel and terminal frequency increment is initiated to be value saved in EEPROM of last power-down.

1: not save

When inverter is energized, panel and terminal frequency increment is initiated to be 0.

LED tens' digit: whether hold setting frequency after stop

0: stop to hold



Set frequency as final correction value when inverter stops.

1: not hold Restore frequency as F0.05 when inverter stops.

LED hundreds' digit: UP/DOWN negative frequency adjustment



0: invalid

1: valid

When valid is selected,  ,  and terminal UP/DOWN can adjust negative and positive frequency.

F0.05	Running frequency digital setting	
	0.0~【F0.07】	50.0

When select digital assignment 1, F0.05 is initial value of digital frequency setting.

Adjust  and  key. . After stop and power-down, F0.04 decides whether save final value into EEPROM.

When select digital assignment 2, F0.05 is initial value of digital frequency setting.

Adjust UP/Down terminal. After stop and power-down, F0.04 decides whether save final value into EEPROM.

F0.06	Max. output frequency	
	MAX { 50.0, 【F0.07】 } ~2000.0Hz	50.0
F0.07	Upper limit frequency	
	MAX { 0.1, 【F0.08】 } ~ 【F0.06】	50.0
F0.08	Lower limit frequency	
	0.0~ 【F0.07】	0.0

Max. output frequency is max. frequency allowed to export by inverter, the benchmark to set acceleration and deceleration. See f_{max} below. Basic running frequency is the minimal frequency corresponding to max. output voltage. Motor rated frequency is f_b . Max. output voltage V_{max} is output voltage corresponding to basic running frequency, also is motor rated voltage, see V_{max} . f_H and f_L are upper limit frequency and lower limit frequency.

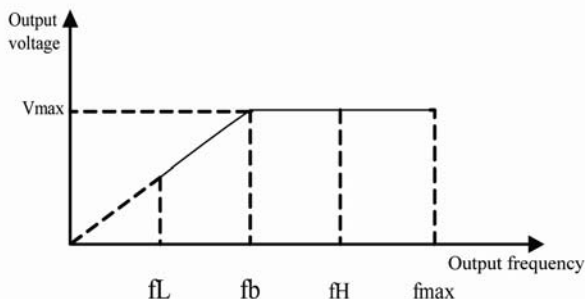



Fig.6-1 Voltage and Frequency Diagram

F0.09	Running direction setting	
	0~2	0

0: forward Actual running direction is same to system default.

1: reverse

When it is selected, actual output phase sequence of inverter will be opposite to system default. If keyboard controls,  key and FWD terminal will become reverse control.

2: prohibit reverse

Inverter only can forward. This function is applied when reverse running may bring danger or property losses.

 **Tip:**

This function code is valid for running direction in all running command channels.

F0.10	Acceleration time1	
	0.1~3600.0S	Type setting
F0.11	Deceleration time 1	
	0.1~3600.0S	Type setting

Acceleration time means the time when inverter accelerates from zero to max. output frequency. See t1 below. Deceleration means the time when inverter decreases from max. output frequency to zero. See t2.

This series has two acceleration and deceleration time parameter groups. Another ACC/DEC time group is defined in F1.13~F1.14. Factory default of ACC/DEC time is 10.0S. If another ACC/DEC time group is selected, use multi-functional terminal (Refer to F5 function code). ACC/DEC time during jog running is set separately in F1.11 and F1.12.

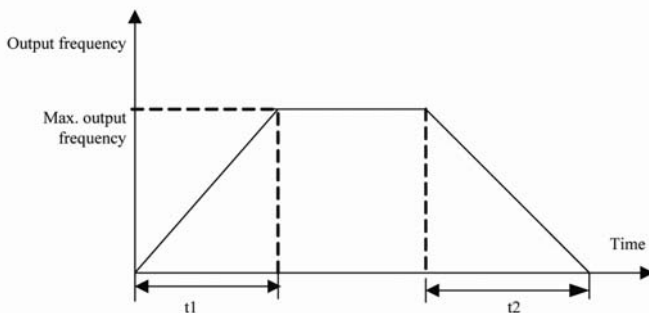

Fig.6-2 ACC Time and DEC Time Diagram

F0.12	Carrier frequency setting	
	1.0~12.0KHz	Type setting

Power (KW)	Carrier (KHz)	Frequency (KHz)
0.4~4.0	6.0	1.0~12.0
5.5~7.5	5.5	1.0~12.0

It can set carrier frequency of exporting PWM wave by inverter. Carrier frequency will affect motor running noise. For silent running, properly increase frequency. However, calorific value and electromagnetic interference will increase.

If carrier frequency exceeds factory value, inverter should derate. Generally, inverter derate 5% frequency when carrier increases 1KHz.



Note:

Carrier upper limit could be 12.0KHz if any condition below is satisfied:

- 1: Select magnetic flux vector control mode or automatic torque lifting mode.
- 2: Dead-time compensation is valid.

F0.13	Parameter initiation	
	0~3	0

0: no operation

Inverter writes and reads parameter as normal. Changing this function code is related to user password setting status and current working status of inverter.

1: restore factory setting 1

All user parameters recover to factory value by model (FC.05, FA.16~FA.18 excluded).

2: restore factory setting 2

All user parameters recover to factory value by model (FC.05, FA.16~FA.18 and motor group parameter excluded).

3: clear fault record

Clear fault record (D-21~D-28). This function code clears after operation.

F0.14	Parameter writing protection	
	0~2	0

0: allow to change all parameters (All parameters can be changed when stop, however, some can not be changed when running).

1: only allow to change frequency setting parameter (F0.02~F0.08)

2: prohibit changing all parameters (this function code excluded)

It avoids inverter parameter setting from random modification by others. It is 0 upon factory shipment. Default all parameters are allowed to change.

F0.15	Key setting	
	00~32	30

LED unit's digit: key function selection

0: JOG function



key is jog control, and has current running direction.

1: forward and reverse switch

When inverter is running,  key can act as switch key. Invalid when inverter stops. It is only valid for keyboard running command channel.

2: clear  、  key frequency setting

Clear panel frequency increment. Refer to F0.02 description.

3: reverse control



key controls motor reverse running as reverse key.

LED tens' digit: key function selection

0: invalid when terminal control acts. Valid when communication runs.

Invalid only when F0.01=1; control inverter to stop only when operation panel and communication control run.

1: valid when terminal control acts. Invalid when communication runs.

Invalid only when F0.01=2; control inverter to stop only when operation panel and communication control run.

2: invalid

Control inverter to stop only when F0.01=0. Invalid when operation panel and communication control run.

3: valid Control inverter to stop in any running command channel mode.

6.2 F1 Group- Assist Running Parameter

F1.00	Start/stop method and DC braking mode	
	0000~1211	0000

LED unit's digit: start method

0: start from starting frequency

1: speed tracking start

Before running, inverter will pass through speed tracking start waiting time (FA.13), then starts at instantaneous frequency and running direction in last stop.

LED tens' digit: stop method

0: decelerated stop

After receiving stop command, inverter will drop output frequency based on deceleration time, and stop after frequency reaches zero. If stop DC braking function is valid, the inverter when the output frequency decrease down to DC braking starting frequency, the inverter will execute DC braking , then stop.

1: free stop

After receiving stop command, inverter stops output and the load stops freely based on mechanical inertia.

LED hundreds' digit: restart after power failure or abnormality

0: prohibit

Inverter will not start if powered on after power failure.

1: start from starting frequency

When powered on after power failure, if meeting start conditions, inverter waits a certain time defined in FA.05 and starts from starting frequency point.

2: speed tracking start

When powered on after power failure, if meeting start conditions, inverter waits a certain time defined in FA.05 and starts by speed tracking mode.

LED thousands' digit: DC braking mode

0: current closed loop

1: voltage open loop

Refer to F1.03 functional description.

F1.01	Starting frequency	
	0.0~50.0HZ	1.0
F1.02	Starting frequency holding time	
	0.0~10.0S	0.0

Starting frequency means initial frequency. See f_s below. For system with high starting torque, the reasonable valid starting frequency can overcome starting difficulty. Starting frequency holding time means the time inverter holds at starting frequency. See t_1 .

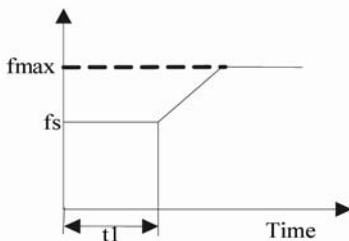

Fig.6-3 Starting Frequency Diagram

F1.03	Starting DC braking current/voltage	
	0.0~150.0%/0.0~30.0%	0.0%
F1.04	Starting DC braking time	
	0.0~30.0S	0.0

If F1.00 thousands' digit selects current closed loop, the value of starting DC braking current is percentage relative to motor rated current, ranging from 0.0 to 150.0%.

If F1.00 thousands' digit selects voltage open loop, the value of starting DC braking voltage is percentage relative to motor rated voltage, ranging from 0.0 to 30.0%

When starting braking time is 0.0s, there is no DC braking, seen below:

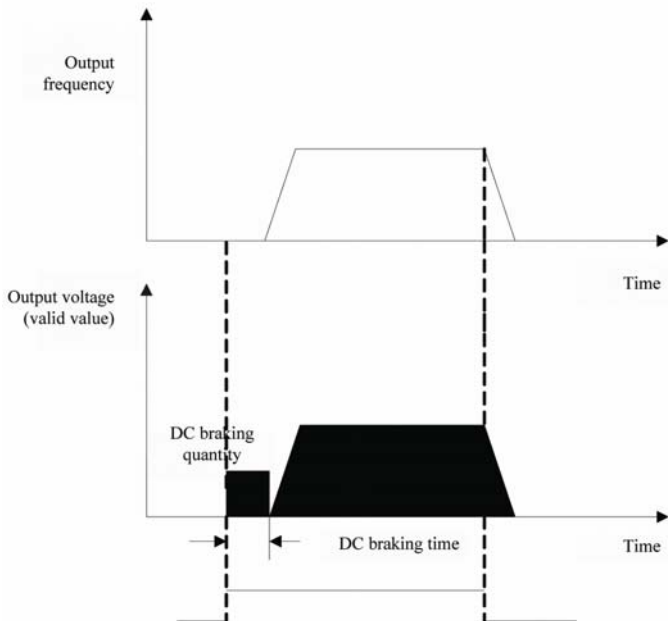

Fig.6-4 Starting DC Braking Diagram

F1.05	Stop DC braking starting frequency	
	0.0~upper limit frequency	0.0
F1.06	Stop DC braking current/voltage	
	0.0~150.0%/0.0~30.0%	0.0%
F1.07	Stop DC braking time	
	0.0~30.0S	0.0
F1.08	Stop DC braking waiting time	
	0.00~100.00S	0.10

If F1.00 thousands' digit selects current closed loop, the value of stop DC braking current is percentage relative to motor rated current, ranging from 0.0 to 150.0%.

If F1.00 thousands' digit selects voltage open loop, the value of stop DC braking voltage is percentage relative to motor rated voltage, ranging from 0.0 to 30.0%.

When stop braking time is 0.0s, there is no DC braking, seen below:

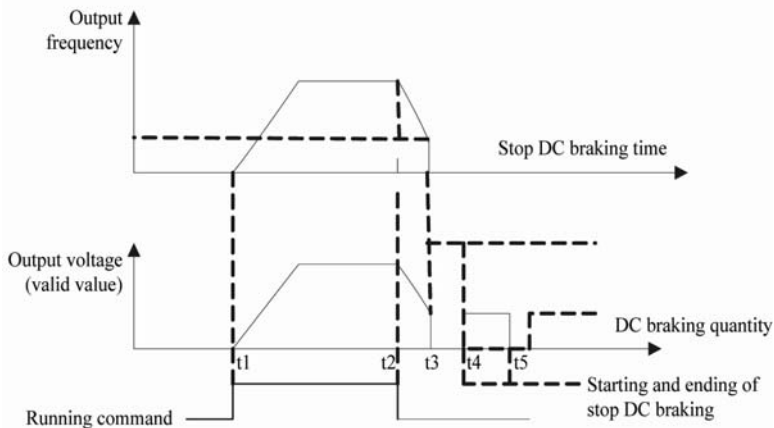

Fig.6-5 Stop DC Braking Diagram

In Fig. 6-5, t1-t2 is machine running time. Machine stops from t2, output frequency decreases, voltage value decreases too. When frequency reduces till designated lower limit frequency, machine enters DC braking waiting time t3-t4. It starts DC braking from t4. t4-t5 is DC braking time.

F1.09	Forward jog frequency setting	
	0.0~upper limit frequency	10.0
F1.10	Reverse jog frequency setting	
	0.0~upper limit frequency	10.0
F1.11	Jog acceleration time	
	0.1~3600.0S	10.0
F1.12	Jog deceleration time	
	0.1~3600.0S	10.0

F1.09~F1.12 define parameter related to jog running. As shown in Fig. F6-6, t_1 and t_3 are jog acceleration and deceleration time during actual running. t_2 is jog running time. t_4 is forward and reverse dead-time (F1.17). f_1 is forward jog running frequency (F1.09). f_2 is reverse jog running frequency (F1.10). Forward jog acceleration time t_1 is decided as:

$$t_1 = F1.09 * F0.10 / F0.06$$

Reverse jog deceleration time t_3 is decided as:

$$t_3 = F1.09 * F0.11 / F0.06$$

F1.06 is max. output frequency .

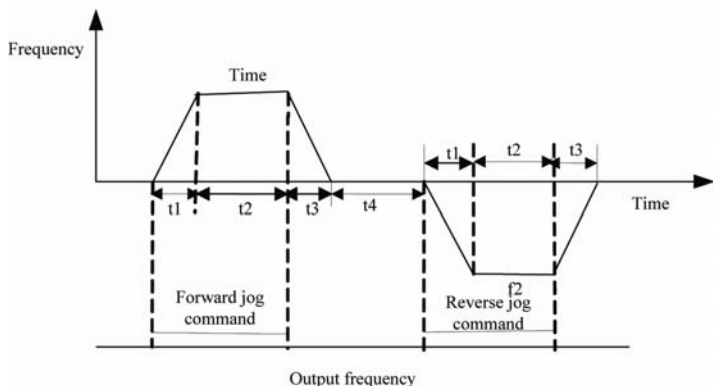

Fig.6-6 Jog Running Diagram

F1.13	Acceleration time 2	
	0.1~3600.0S	10.0
F1.14	Deceleration time 2	
	0.1~3600.0S	10.0

Two ACC/DEC time can be defined, ACC/DEC time 1~2 during running can be selected through control terminal, referring to definition of the forth function in F5.00~F5.06. ACC/DEC time1~2. Define ACC/DEC time in PLC. Refer to F8.15~F8.16 setting.

F1.15	Hopping frequency 1	
	0.0~upper limit frequency	0.0

F1.16	Hopping range	
	0.0~10.0Hz	0.0

The function code allows inverter output frequency to avoid resonance frequency point of mechanical load. Inverter setting frequency is assigned in hopping manner near some frequency point shown in Fig. 6-7. Inverter frequency will not stably run within hopping frequency range, but goes through this range when accelerate and decelerate.

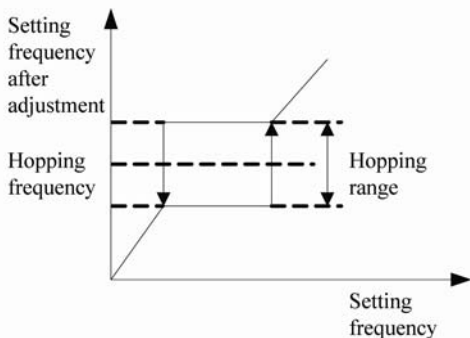

Fig.6-7 Hopping Frequency Setting Diagram

F1.17	Forward and Reverse Dead-time	
	0.0~10.0S	0.0

The waiting time at output zero frequency when inverter changes from forward to reverse, or vice versa, shown in t_1 below.

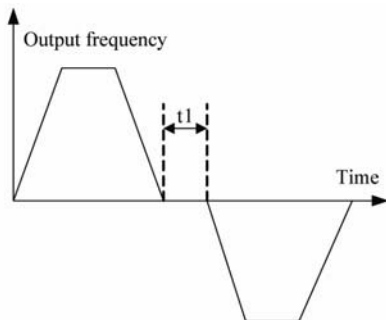

Fig.6-8 Forward and Reverse Dead-time Diagram

F1.18	Treatment of reaching lower limit frequency	
	0~1	0

0: zero-speed running

Inverter runs at zero speed when setting frequency is lower than lower limit frequency (F0.08).

1: run at lower limit frequency

Inverter runs at lower limit speed when setting frequency is lower than lower limit frequency (F0.08).

6.3 F2 Group- V/F Control Parameter

F2.00	V/F curve setting	
	0~3	0

0: linear curve

It is suitable to common constant torque load. Output voltage is in linear relation to output frequency. See straight line 0 in Fig. F2-1.

1: reduced torque curve1 (1.5 power)

Reduced torque curve 1. Output voltage is 1.5 power of output frequency. For example, curve 1 in Fig.F2-1.

2: reduced torque curve2 (2.0 power)

Reduced torque curve 2. Output voltage is 2.0 power of output frequency. For example, curve 2 in Fig.F2-1.

3: multi-point V/F curve

When F2.00 is 3, user can define V/F curve through F2.03~F2.08, define V/F curve by increasing (V1, F1)、(V2, F2)、(V3, F3) three-point line to match special load features, see in Fig. 6-9:

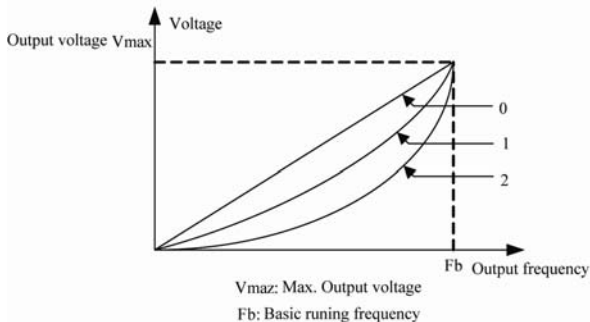

Fig.6-9 V/F Curve Diagram

F2.01	Torque lifting quantity	
	0.0~30.0%	0.0%
F2.02	Torque lifting cut-off frequency	
	0.00~50.0Hz	50.0

F2.01 is relative to max. output voltage. 0.0 means automatic torque lifting. If not 0.00, it means manual lifting. F2.02 defines lifting cut-off frequency point f_z when torque is lifted manually, see in Fig. 6-10:

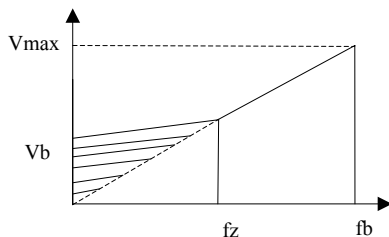

Fig.6-10 Torque Lifting Diagram

F2.03	V/F frequency value F1	
	0.1~frequency value F2	12.5
F2.04	V/F voltage valueV1	
	0.0~voltage value V2	25.0%
F2.05	V/F frequency valueF2	
	frequency value F1~frequency value F3	25.0
F2.06	V/F voltage valueV2	
	voltage value V1~voltage value V3	50.0%
F2.07	V/F frequency valueF3	
	frequency value F3~motor rated frequency (F3.04)	37.5
F2.08	V/F voltage valueV3	
	voltage valueV3 ~ 100.0 % *Uoute (motor rated voltage 【F3.01】)	75.0%

Voltage and frequency diagram are seen below:

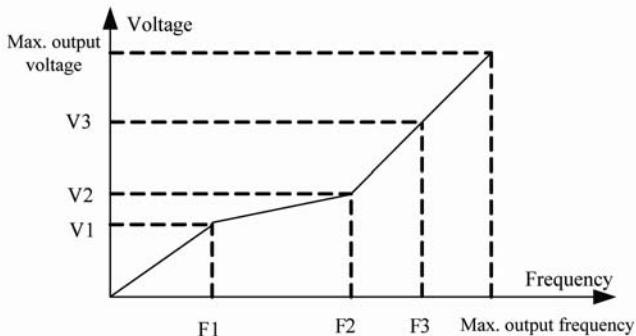

Fig. 6-11 User Setting V/F Curve Diagram

6.4 F3 Group- Motor Parameter

F3.00	Inverter load type	
	0~1	0

0: M type (constant-torque type)

1: FP type (fan water pump type)

M/FP model is combined in this inverter, using M model with low power as FP with high power. For example, to change 1.5KW M model into 2.2 KW FP model, set this parameter as 1.

When it sets 1, rated current will increase to ensure inverter power matched with motor. No need to set motor parameter.

F3.01	motor rated voltage	
	0~250V	220
	0~500V	380
F3.02	motor rated current	
	0.1~3000.0A	Type setting
F3.03	Motor rated speed	
	0~60000RPM	Type setting
F3.04	motor rated frequency	
	1.0~2000.0Hz	50.0Hz

F3.05	Motor no-load current	
	0.1~【F3.02】	Type setting

Current when motor runs at rated voltage and frequency with no load are the Rated exciting current of motor generally.

F3.06	Motor stator resistance	
	0.001~20.000Ω	Type setting

Phase resistance as motor stator side.

F3.07	Motor parameter tuning	
	0~2	0

0: no action

1: static tuning (measure stator resistance)

Parameter measuring mode when motor keeps still. It is suitable when motor and load can not be uncoupled.

2: complete tuning (measure stator resistance and no-load current)

Complete parameter measuring mode. Try to use it when motor and load are uncoupled.

In magnetic flux vector control method and VF control +automatic torque lifting method, the stator resistance of motor and no-load current are key parameters in system control. So measure these parameters by tuning motor parameters.

Correctly set motor rated voltage, current and rated speed (check motor name plate) and set ACC/DEC time(not too small, or else overcurrent or overvoltage protection will be required when tuning). Start tuning function.

If tuning does not pass, it can adopt motor default parameters to get better control performance of motor that is compromised however.

6.5 F4 group- Performance optimization parameter

F4.00	PWM mode	
	0000~1111	1001

LED unit's digit: dead-time compensation selection

0: invalid

1: valid

If valid is chosen, full-frequency dead-time compensation will occur in all control methods. It is intended for manufacturer commissioning and not recommended setting by users.

LED tens' digit: overmodulation selection

Overmodulation function means to increase output voltage by adjusting bus voltage utilization rate. When overmodulation is valid, output harmonic will be more. If it runs with heavy load under low voltage for long or high-frequency running torque (above 50HZ) is not enough, this function can be opened.

0: invalid

1: valid

LED hundreds' digit: carrier mode selection

0: PWM mode 1 (routine)

Current output is stable and power tube has small calorific value under high frequency.

1: PWM mode 2 (full-frequency 7 sections)

Current output is stable and full-frequency power tube has big calorific value.

LED thousands' digit: low-frequency carrier adjustment

0: invalid

1: valid

Reduce low-frequency torque pulse of motor and increase running stability.

F4.01	Acceleration current limiting coefficient	
	0~255	10

Adjust the ability in inhibiting overcurrent when inverter accelerates. If it is 0, close this function. The bigger it is, the stronger inhibiting ability will be.

For load with small inertia, this value should be small, or else the system dynamic response will be slow. For load with big inertia, this value will be big, or else there would be bad inhibiting effect, and overvoltage fault may occur.

F4.02	Constant speed current limiting coefficient	
	0~255	0

Adjust the ability in inhibiting overcurrent when inverter runs at constant speed. If it is 0, close this function. The bigger it is, quicker response, the stronger inhibiting ability will be.

F4.03	Deceleration voltage limiting coefficient	
	0~255	10

Adjust the ability in inhibiting overvoltage when inverter decelerates. If it is 0, close this function. The bigger it is, the stronger inhibiting ability will be.

For load with small inertia, this value should be small, or else the system dynamic response will be slow. For load with big inertia, this value will be big, or else there would be bad inhibiting effect, and overvoltage fault may occur.



Note:

F4.01~F4.03 are used to promote acceleration and deceleration performance. For situation where high acc/dec requirements are raised, it should adjust them together with F9.03~F9.04 parameter.

F4.04	Slip frequency compensation	
	0~200%	0%/100%

It is mainly used to compensate speed drop caused by motor carrying load, increase motor speed control precision if reasonably set. 100% compensation is equal to rated slip frequency of motor.

When this function is used, it must fully tune motor parameters to get accurate motor no-load current, if not, can be manually input. Generally, motor no-load current is approx. 40-60% of rated current.

Besides, motor rated current and speed information must be correct as shown by motor name plate, or else compensation value will be wrong.

F4.05	Slip frequency compensation filter coefficient	
	0~255	5

Adjust response speed of slip frequency compensation. The bigger it is, quicker response, the more stable motor speed will be.

F4.06	Magnetic flux proportional gain	
	0.01~10.00	1.00

F4.07	Magnetic flux integration time	
	0.01~10.00S	1.00

The above function codes can adjust magnetic flux compensation and speed when motor runs at low speed. It is mainly intended for magnetic flux vector control mode, not necessarily adjusted generally.

6.6 F5 group- Switching value input and output

F5.00	Input terminal DI1 function	
	0~31	12
F5.01	Input terminal DI2 function	
	0~31	13
F5.02	Input terminal DI3 function	
	0~31	17
F5.03	Input terminal DI4 function	
	0~31	18
F5.04	Input terminal DI5 function	
	0~31	24
F5.05	Input terminal DI6 function	
	0~31	0
F5.06	Input terminal DI7 function	
	0~31	0

Select the function of multi-function input terminal DI1~DI7 according to needs. Define DI1~DI7 function through setting F5.00~F5.06.

- 0: control terminal in idle
- 1: multi-speed selection S1
- 2: multi-speed selection S2
- 3: multi-speed selection S3

Selection of 7 speeds are available at most through selecting On/Off combination of function terminals, seen below:

Multi-speed selection S3	Multi-speed selection S2	Multi-speed selection S1	Speed
OFF	OFF	OFF	0
OFF	OFF	ON	1
OFF	ON	OFF	2
OFF	ON	ON	3
ON	OFF	OFF	4
ON	OFF	ON	5
ON	ON	OFF	6
ON	ON	ON	7

4: ACC/DEC time selection

Select ACC time 2/DEC time 2 when this terminal is valid. Or else, select ACC time 1/DEC time 1.

5: ACC/DEC prohibiting command

Keep inverter not affected by external signal (stop command excluded) and maintain it to run at current frequency.

6: Running command forced as terminal

Running command is forcibly changed into terminal control from current channel when this terminal is valid. Disconnect terminal and return previous running command channel.

7: Running command forced as communication

Running command is forcibly changed into communication control from current channel when this terminal is valid. Disconnect terminal and return previous running command channel.

8: running command channel selection 1

9: running command channel selection 2

Selection of 3 running command channels are available at most through selecting On/Off combination of function terminals, seen below:

Running command channel selection terminal 2	Running command channel selection terminal 1	Running command channel
OFF	OFF	Confirmed by Function code F0.01
OFF	ON	0: operation panel running command channel
ON	OFF	1: terminal running command channel
ON	ON	2: communication running command channel

10: Forward jog control

When terminal is short-circuited to COM, the inverter forward jogs and is valid only when F0.01=1.

11: Reverse jog control

When terminal is short-circuited to COM, the inverter reversely jogs and is valid only when F0.01=1.

12: Forward control (FWD)

When terminal is short-circuited to COM, the inverter forward runs and is valid only when F0.01=1.

13: Reverse control (REV)

When terminal is short-circuited to COM, the inverter reverse runs and is valid only when F0.01=1.

14: Three-wire run control

Refer to function description of F5.07 running mode 2 and 3 (3-wire control mode 1 and

2). 15: Free stop control

When terminal is short-circuited to COM, the inverter freely shuts down.

16: Stop DC braking command

Execute DC braking to motor stopping. Emergency stop and precise positioning. Braking start frequency and braking current are defined in F1.05~F1.06. Braking time takes maximal value from F1.07 defined time and valid duration of this control terminal.

17: External stop signal input (STOP)

When terminal is short-circuited to COM, the inverter will stop accordingly.(F1.00).

18: External reset signal input (RST)

When inverter fails, this terminal can reset fault. Its function is same to  key.

19: External equipment fault input

Input fault signal of external equipment through this terminal, allow inverter to monitor external equipment fault. After receiving fault signal, the inverter makes protection action and shows "E-13".

20: Frequency up command (UP)

When terminal is short-circuited to COM, terminal frequency increment increases. It is valid only when frequency assignment channel is digital assignment 2(adjust UP/DOWN terminal).

21: Frequency down command (DOWN)

When terminal is short-circuited to COM, terminal frequency increment reduces. It is valid only when frequency assignment channel is digital assignment 2(adjust UP/DOWN terminal).

22: UP/DOWN terminal frequency clear

Clear terminal frequency increment.

23: Frequency change to AI1

When terminal is short-circuited to COM, it can forcibly set current frequency assignment channel as AI1. Break terminal, frequency assignment channel returns original assignment value.

24: Pulse frequency input (only valid for DI5)

Only valid for multi-functional input terminal DI5. It receives pulse signal as frequency assignment. Relation between pulse signal frequency and setting frequency refers to F6.08~F6.11 functional description.

25: counter clear signal

Clear inner counter when terminal is short-circuited to COM, used together with the 26th function.

26: counter trigger signal

When count pulse input port receives one pulse, counter adds 1. Max. count pulse frequency is 80Hz. If higher frequency is required, input pulse through DI5 high-speed port, seeing F5.16~F5.17 functional description.

27: timer clear signal

Clear inner timer when terminal is short-circuited to COM, used together with the 28th function.

28: timer trigger signal

Trigger port of inner timer, see F5.18 functional description.

29~31: retained

F5.07	FWD/REV terminal control mode	
	0~3	0

It defines four ways of controlling inverter running through external terminal.

Premises are shown below: set multi-functional terminal DI1 as forward (FWD) function ([F5.00]=12) , DI2 as reverse (REV) function ([F5.01]=13) , DI3 as 3-wire running control function ([F5.01]=14) , K as 3-wire control terminal. (Remarks: the above three commands can be set by using any three terminals from DI 1 to DI7. For convenient understanding, we select DI1, DI2 and DI3 to describe.)

0: 2-wire control mode1

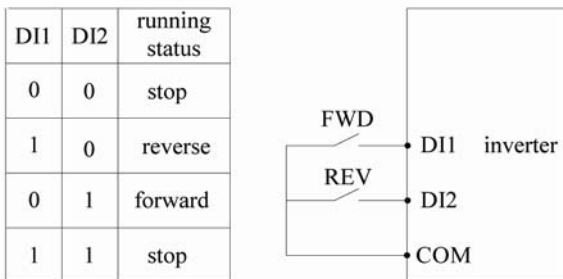

Fig.6-12 Diagram of 2-wire Control Mode 1

1: 2-wire control mode 2

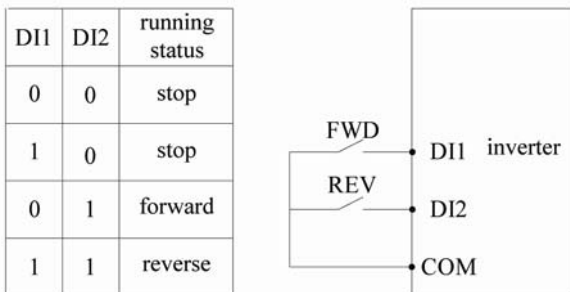

Fig.6-13 Diagram of 2-wire Control Mode 2

2: 3-wire control mode1

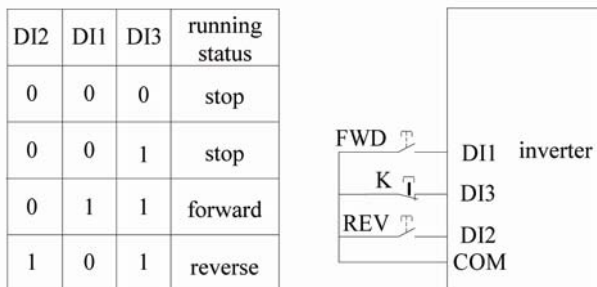

Fig.6-14 Diagram of 3-wire Control Mode 1

3: 3-wire control mode 2

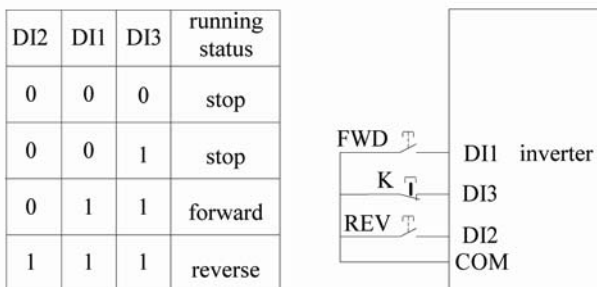

Fig.6-15 Diagram of 3-wire Control Mode 2

 **Note:**

It is defined that it reverses stably when REV terminal is normally closed. If disconnected, it will return forward running.

F5.08	Terminal function detection selection upon power-on	
	0~1	0

0: invalid terminal running command upon power-on

Inverter will not start even when detecting valid terminal running command upon power-on (close). Inverter only starts after terminal disconnects and closes again.

1: valid terminal running command upon power-on

Inverter will start when detecting valid terminal running command upon power-on (close). It will bring unexpected start. Be cautious.

F5.09	UP/DOWN terminal change rate	
	0.1Hz~99.9Hz/S	1.0

Set frequency change rate when UP/DOWN terminal frequency is set. The size of frequency change when UP/DOWN terminal is short-circuited to COM for one second.

F5.10	Digital input terminal filter times	
	1~10	2

Used to set sensitivity of input terminal. If digital input terminal is easily disturbed, wrong action will be caused. Increase this parameter and anti-disturbance ability will be promoted. However, too high value will compromise sensitivity.

F5.11	Open-loop collector output terminal DO1 setting	
	0~21	0
F5.12	Programmable relay output R1 setting	
	0~21	8

0: indication when inverter runs

Indication signal that is exported when inverter is running.

1: indication when inverter runs at zero speed

Indication signal that is exported when inverter output frequency is 0.0Hz but inverter is running.

2: inverter is ready for running

Indication signal that is exported when inverter powers on, free from fault, normal bus voltage, invalid inverter prohibiting running terminal, can directly receives running command.

3: frequency/speed reach signal (FAR)

Refer to F5.13 functional description. 4: frequency/speed level detection signal (FDT1)

Refer to F5.14~F5.15 functional description.

5: shut-down due to external equipment fault

Indication signal that is exported when inverter shuts down due to external equipment fault.

6: output frequency reaches upper limit

Indication signal that is exported when inverter frequency reaches upper limit.

7: output frequency reaches lower limit

Indication signal that is exported when inverter output frequency reaches lower limit.

8: inverter fault

Indication signal that is exported when inverter fails.

9: running at programmable multi-speed stage completes

One valid pulse signal is exported after it completes one programmable multi-speed stage. Signal width is 500mS.

10: programmable multi-speed running complete one cycle

One valid pulse signal is exported after one programmable multi-speed cycle (PLC) completes. Signal width is 500mS.

11: timing time reach

Indication signal is exported when actual timing time \geq F5.18(set timing time).

12: counter detection signal

Indication signal is exported when count detection value reaches, referring to F5.17 functional description.

13: counter reset signal

Indication signal is exported when count reset value reaches, referring to F5.16 functional description.

14: inverter overload pre-alarm signal

Indication signal is exported by alarm delay time (F5.20) when inverter output current is more than overload pre-alarm level (F5.19). It is often used for overload pre-alarm.

15: overtorque indication

Inverter exports indication signal according to FA.06~FA.08.

16: assist motor

Indication signal is exported when feedback pressure is lower than defined pressure and frequency reaches upper limit and then assist motor starts. If feedback pressure is higher than defined pressure and frequency reaches lower limit, indication signal will be removed and assist motor is closed. Delay setting of Y2/R1 terminal refers to F5.21~F5.22 functional description.

It realizes simple one dragging and two constant-pressure water supply control. It is valid only when combined with PID control.

17: PID feedback disconnection alarm

Signal that is exported by feedback disconnection detection time (F9.07) when PID feedback value is lower than feedback disconnection value (F9.06) and tens' digit in F9.00 is set as 2 or 3.

18: 485 communication failure alarm

Signal that is exported when inverter communication failure alarm (A-16) occurs.

19: under overcurrent limiting action

Signal that is exported when inverter makes overcurrent limiting action.

20: under overvoltage limiting action

Signal that is exported when inverter makes overvoltage limiting action.

21: hibernation

Signal that is exported when inverter hibernates.

F5.13	FAR detection amplitude when frequency arrives	
	0.0Hz~15.0Hz	5.0

This function code is supplementary description to the third function of F5.11~F5.12. When output frequency of inverter is within positive and negative detection width of setting frequency, the terminal will export valid signal(low level), shown below.

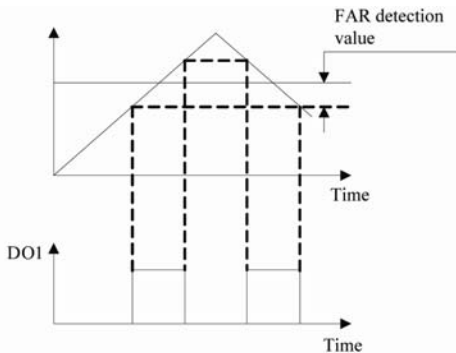

Fig.6-16 Diagram of Frequency Arriving

F5.14	FDT1 level setting	
	0.0Hz ~ 【F0.07】	10.0
F5.15	FDT1 lagged value	
	0.0Hz~30.0Hz	1.0

The above function code (F6.14~F6.15) is supplementary description to the forth function of F6.11~F6.12. When inverter output frequency rises and exceeds FDT level value, valid signal will be exported (low level). When output frequency is below FDT signal (setting value-lagged value), invalid signal will be exported (high impedance), seen below:

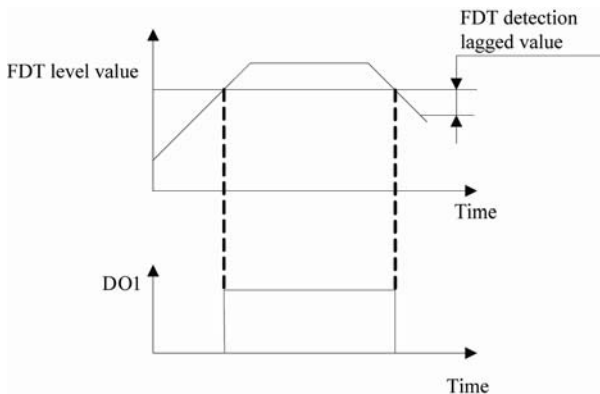

Fig.6-17 Diagram of Frequency Level Detection

F5.16	Counter reset value setting	
	【F5.17】 ~65535	1
F5.17	Counter detection value setting	
	0~ 【F5.16】	1

It defines counting reset value and detection value of counter. When it reaches value defined by F5.16, multi-functional output terminal (counter reset signal output) will export valid signal. When next count edge reaches, count value will be cleared and reset signal and detection signal are removed.

When it reaches value defined by F5.17, multi-functional output terminal (counter detection signal output) will export valid signal.

As shown below: set programmable relay output as reset signal output, open-loop collector output DO1 as counter detection output, F5.16 is 8, and F5.17 is 5. When detection value is “5”, DO1 exports valid signal and keeps it. When reset value reaches “8”, relay exports one valid signal of one pulse cycle and clear counter. DO1 and relay remove exported signal.

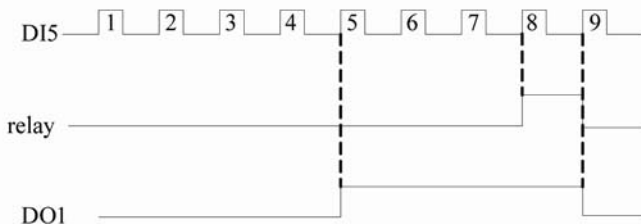

Fig.6-18 Diagram of Counter Reset Setting and Counter Detection

F5.18	Timing time setting	
	0~65535S	0

It defines timing time of inner timer.

F5.19	Inverter overload pre-alarm level	
	120~150%	120%

Overload pre-alarm monitors overload status before inverter makes overload protection action.

Overload pre-alarm level defines current threshold when inverter makes overload pre-alarm action. It is percentage corresponding to inverter rated current .

F5.20	Inverter overload pre-alarm delay	
	0.0~15.0s	5.0

Overload pre-alarm defines the delay of inverter current continuously being more than overload pre-alarm level (F5.19) and exporting overload pre-alarm signal.

F5.21	R1 close delay	
	0.0~260.0s	0.0
F5.22	R1 break delay	
	0.0~260.0s	0.0

It defines the delay of relay R1 status change and output change.

6.7 F6group-Analog and Pulse Input and Output Parameter

F6.00	AI1 lower-limit value	
	0.00 ~ 【F6.01】	0.00
F6.01	AI1 upper-limit voltage	
	【F6.00】 ~ 10.00V	10.00
F6.02	Setting corresponding to AI1 lower-limit	
	-100.0% ~ 100.0%	0.0%
F6.03	Setting corresponding to AI1 upper-limit	
	-100.0% ~ 100.0%	100.0%
F6.04	AI2 lower-limit value	
	0.00 ~ 【F6.05】	0.00
F6.05	AI2 upper-limit voltage	
	【F6.04】 ~ 10.00V	10.00
F6.06	Setting corresponding to AI2 lower-limit	
	-100.0% ~ 100.0%	0.0%
F6.07	Setting corresponding to AI2 upper -limit	
	-100.0% ~ 100.0%	100.0%

It defines input range of analog input voltage channel AI1 and AI2 and their corresponding physical quantities. AI1 is only used as voltage input. AI2 can be set as voltage/current input through JP2 jumper. Digital setting is set as 0~20.00mA and 0~10V. Particular setting is decided by actual input signal.

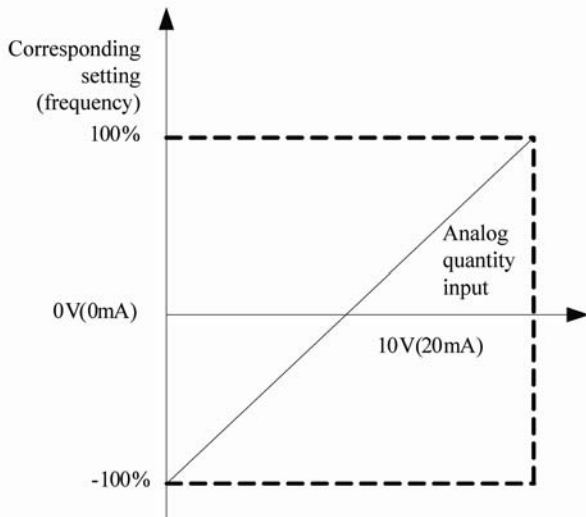

Fig.6-19 Diagram of Relation between Input Analog Quantity and Frequency

F6.08	External pulse input lower-limit frequency	
	0.00~【F6.09】	0.00
F6.09	External pulse input upper limit frequency	
	【F6.08】~50.0kHz	20.0
F	Setting corresponding to external pulse lower-limit	
	-100.0%~100.0%	0.0%
F6.11	Setting corresponding to external pulse upper-limit	
	-100.0%~100.0%	100.0%

It defines input range of pulse input channel and setting frequency percentage(relative to max. output frequency).

When F0.02 is 6, it can select DI5 pulse frequency input in F5.04 item and confirm output frequency of inverter.

F6.12	Analog input signal filter time constant	
	0.1~5.0s	0.1

The inverter filters external input analog signal according to defined filter time constant to eliminate the influence of disturbance signal. The bigger time constant is, stronger anti-disturbance ability, more stable control will be, however, response will be slower. If optimal value can not be confirmed in actual application, it should adjust this parameter based on stable control and response delay.

F6.13	Analog input anti-shake deviation limit	
	0.00V~0.10V	0.00

When analog input signal fluctuates frequently nearby assigned value, it can inhibit its fluctuation by setting F6.13.

F6.14	Zero-frequency threshold	
	0.0~50.0Hz	0.0
F6.15	Zero-frequency return difference	
	0.0~50.0Hz	0.0

These function codes are used to set zero-frequency return difference. Take analog AI1 current assigned channel as example, see Fig. 6-20.

Start process:

After running commands are sent, motor starts only when analog AI1 current reaches or exceeds I_b , setting frequency reaches f_b . Motor accelerates frequency corresponding to analog AI1 current.

Stop process:

When AI1 current reduces to I_b , inverter does not immediately stop. Inverter stops only when AI1 current reduces to I_a and setting frequency is f_a . f_b is defined as zero-frequency running threshold, defined by F6.14. $f_b - f_a$ value is defined as zero-frequency return difference, defined by F6.15.

This function is used as hibernation function to realize energy-saving running. The width of return difference avoids the inverter starts frequently at threshold frequency.

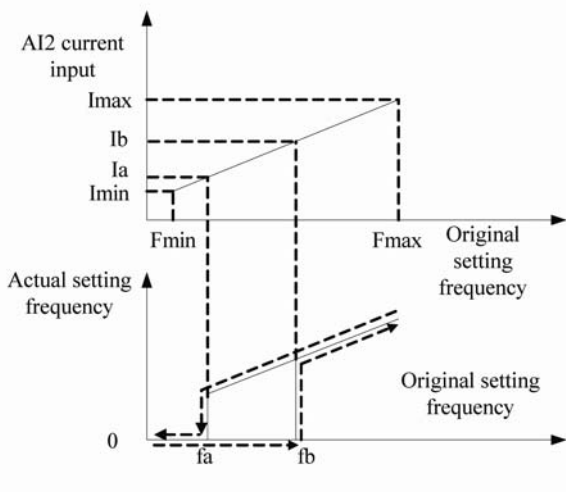

f_b : zero-frequency running threshold

f_a : f_b -zero-frequency return difference

Fig. 6-20 Zero-frequency Function Diagram

F6.16	AO analog quantity output terminal function selection	
	000~808	200

Confirm the corresponding relation between multi-functional analog quantity output terminal AO and each physical quantity, seen below:

Item	AO	Range
Output frequency (before slip compensation)	0V/0mA~AOupper limit	0.0~upper limit frequency
	2V/4mA~AOupper limit	0.0~upper limit frequency
Setting frequency	0V/0mA~AOupper limit	0.0~setting frequency
	2V/4mA~AOupper limit	0.0~setting frequency
Output current	0V/0mA~AOupper limit	0.0~2.0 times of rated current
	2V/4mA~AOupper limit	0.0~2.0 times of rated current
Motor speed	0V/0mA~AOupper limit	0~Motor synchronous speed
	2V/4mA~AOupper limit	0~Motor synchronous speed

Output voltage	0V/0mA~AOupper limit	0~max. rated output voltage
	2V/4mA~AO upper limit	0~max. rated output voltage
Bus voltage	0V/0mA~AO upper limit	0~1000V
	2V/4mA~AO upper limit	0~1000V
AI1	0V/0mA~AO upper limit	0.00~10.00V
	2V/4mA~AO upper limit	0.00~10.00V
AI2	0V/0mA~AO upper limit	0.00~20.00mA
	2V/4mA~AO upper limit	0.00~20.00mA
External input pulse frequency	0V/0mA~AO upper limit	0.00~100.0KHZ
	2V/4mA~AO upper limit	0.00~100.0KHZ

LED unit's digit: AO1selection

- 0: output frequency
- 1: setting frequency
- 2: output current
- 3: motor speed
- 4: output voltage
- 5: bus voltage
- 6: AI1
- 7: AI2
- 8: external input pulse frequency

LED tens' digit: retain**LED hundreds' digit: retain****LED thousands' digit: retain**

F6.17	AO analog output range selection	
	000~101	000

LED unit's digit: A01 range setting

- 0: 0~10V or 0~20mA
- 1: 2~10V or 4~20mA

LED tens' digit: retain**LED hundreds' digit: retain****LED thousands' digit: retain**

F6.18	AO1 gain setting	
	0.0%~100.0%	100.0%

The above function code defines gain coefficient of analog output AO1. When factory value is 100%, the output voltage/current will be within 0~10V/0~20mA.

6.8 F7 Group- Process PID Parameter

A complete analog feedback control system will be formed by setting this parameter group.

Analog feedback control system: assignment quantity AI 1 input. Change feedback quantity into 4~20mA current through inverter AI 2. Form analog close-loop control system by using built-in PI regulator, shown below:

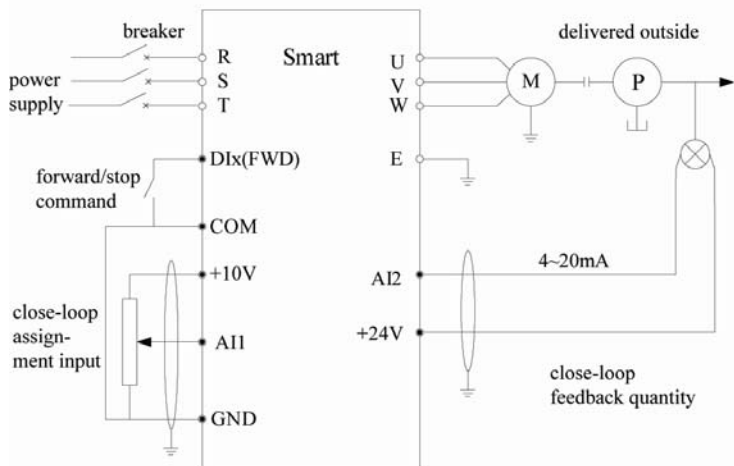

Fig.6-21 Diagram of Analog Feedback Control System

PID regulating functions are:

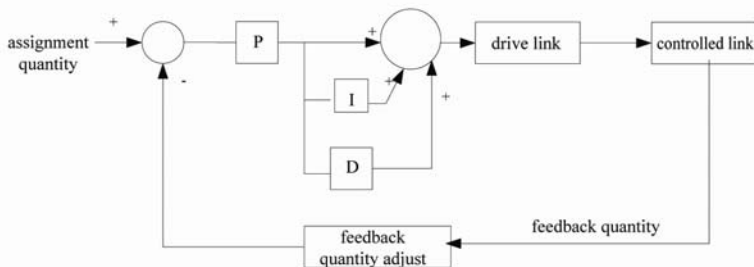

Fig.6-22 PID Regulation Diagram

F7.00	PID function setting 1	
	0000~1011	0000

LED unit's digit: PID enable control

0: invalid

1: valid

Realize PID function when this parameter is valid.

LED tens' digit: PID regulating features

0: positive effect

PID realizes balance when feedback signal is more than PID assignment quantity, inverter reduces output frequency (decrease feedback signal), meaning positive effect, such as tension control of rolling, constant-pressure water supply control, etc.

1: negative effect

PID realizes balance when feedback signal is more than PID assignment quantity, inverter increases output frequency (decrease feedback signal), meaning negative effect, such as tension control of unrolling, central air-conditioner control, etc.

LED hundreds' digit: retain

LED thousands' digit: sleep stop method selection

0: deceleration to stop

1: free stop

F7.01	PID function setting 2	
	0000~1128	1000

LED unit's digit: PID assignment channel selection

PID feedback value default is 0 when different is negative.

0: keyboard potentiometer

PID assignment quantity is given by potentiometer on operation panel.

1: Digital assignment

PID assignment quantity is set by digital assignment in F7.02.

2: AI1

PID assignment quantity is set by external voltage signal AI1 (0~10V) .

3: AI2

PID assignment quantity is set by external voltage signal AI2 (0~20mA/0~10V) .

4: terminal pulse

5: AI1+AI2

6: AI1-AI2

7: MIN {AI1,AI2}

8: MAX {AI1,AI2}

LED tens' digit: PID feedback channel selection

0: AI1

PID assignment quantity is set by external voltage signal AI1 (0~10V) .

1: AI2

PID assignment quantity is set by external voltage signal AI2 (0~20mA/0~10V) .

2: terminal pulse

LED hundreds' digit: PID self-adaptive model (retain)

0: invalid

1: valid

LED thousands' digit: PID hibernation method

0: It hibernates when feedback pressure higher or lower than sleep threshold (retain)

1: It hibernates when feedback pressure and output frequency are stable.

There are two cases (see Fig. F7-4):

1) Maintain sleep time[F7.13] and to go sleep if feedback value is lower than assignment value but higher than assignment*(1-setting deviation[F7.11]), output frequency changes within 6%.

2) Maintain sleep time [F7.13] and go sleep if feedback value increases above setting value. Or else, it feedback value reduces below wake threshold [F7.12], maintain wake time[F7.14] and exit sleep.

F7.02	Assignment quantity digital setting	
	0.0~100.0%	0.0

When analog quantity feedback is adopted, this function code realizes to set close-loop control assignment quantity by using keyboard. This function is valid only when close-loop assignment channel chooses digital assignment(F7.01 is 1).

Example: In constant-pressure water supply close-loop control system, it fully considers the relation between remote-control pressure meter range and its output feedback signal. E.g. if the pressure meter range is 0~10Mpa, corresponding to 0~10V voltage, we will need 6Mpa pressure and set assigned digital quantity as 60.0% . So when PID regulation is stable, the required pressure will be 6Mpa.

F7.03	Feedback channel gain	
	0.01~10.00	1.00

When feedback channel is inconsistent to setting channel level, this function will be used to adjust gain of feedback channel signal.

F7.04	Proportional gain P	
	0.01~5.00	1.00
F7.05	Integral time Ti	
	0.0: no integral regulation 0.1~50.0s	1.0
F7.06	Differential time Td	
	0.0: no differential regulation 0.1~10.0s	0.0
F7.07	Sampling cycle T	
	0.0~10.0S	0.0

0.0: automatic sampling mode

Sampling cycle is intended for feedback quantity. Regulator counts once in each sampling cycle. The bigger sampling cycle is, the slower response will be. However, better effect in inhibiting disturbance signal. No need to set generally.

F7.08	Deviation limit	
	0.0~20.0%	0.0

Deviation limit is the ratio between absolute derivation of system feedback and assignment quantity and assignment quantity. PID regulation does not act when feedback quantity is within derivation limit.

F7.09	Close-loop predetermined frequency	
	0.0~upper limit frequency	0.0
F7.10	Predetermined frequency holding time	
	0.0~1000.0	0.0

It defines inverter running frequency and running time before PID is put into use when PID control is valid. In some control systems, to make controlled target reach predetermined value, the inverter will forcibly export one frequency value F7.09 and frequency holding time F7.10 regarding this function code setting. Frequency holding time unit is pre-set by Fc.04. When controlled target approaches control goal, PID controller will be used to increase response speed, shown below:

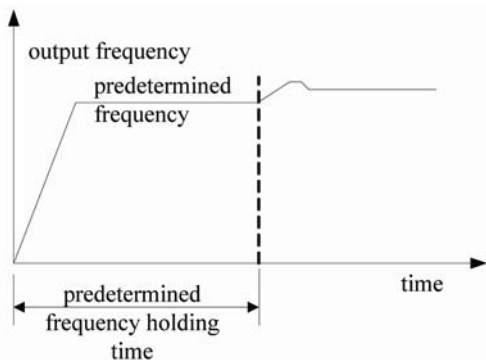

Fig.6-23 Diagram of Close-loop Predetermined Frequency Running

F7.11	Deviation between feedback and setting pressure when entering sleep	
	0.0~50.0%	5.0

Refer to F7.01 thousands' digit functional description.

F7.12	Wake threshold	
	0.0~100.0%	0.0

It defines feedback limit of inverter going from sleep into working. If actual feedback value is lower than this value, the inverter will get away from sleep after delay waiting time defined in F7.14, and start working.

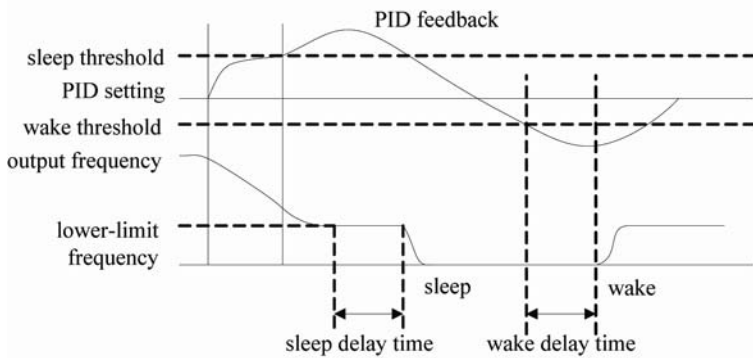

Fig.6-24 Diagram of Sleep and Wake Function

F7.13	Sleep delay time	
	1.0~1000.0	100.0
F7.14	Wake delay time	
	1.0~1000.0	1.0

Time unit is set by FC.04.

6.9 F8 Group- Programmable Running Parameter

F8.00	Programmable running control (simple PLC running)	
	0000~1221	0000

Simple PLC function is a multi-functional generator. The inverter can automatically change running frequency and direction regarding running time to satisfy process requirement. This function is completed by PLC before (programmable controller), now it is realized by inverter itself, shown below:

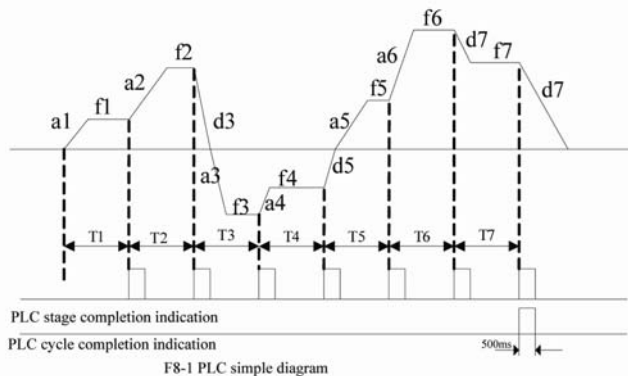

Fig.6-25 Diagram of Simple PLC Running

LED unit's digit: PLC control

0: invalid

1: valid

Realize PLC function when this parameter is valid.

LED tens' digit: running method selection

0: single cycle

Inverter stops when one single cycle completes. Running command is required for its start. If running time at one stage is 0, it will jump this stage and go to next stage, shown below:

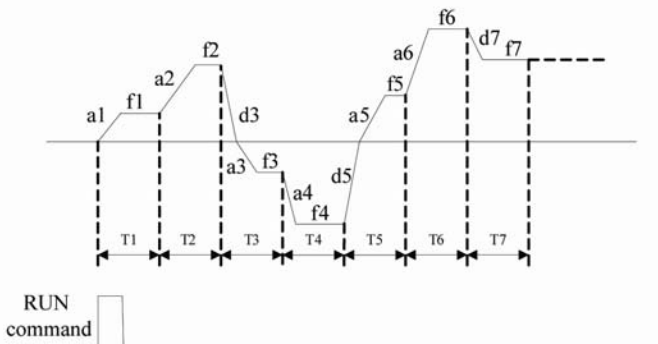

Fig.6-26 Diagram of PLC Single Cycle

1: continuous cycle

Inverter goes into next cycle after one cycle completes and stops until stop command is given, seen below:

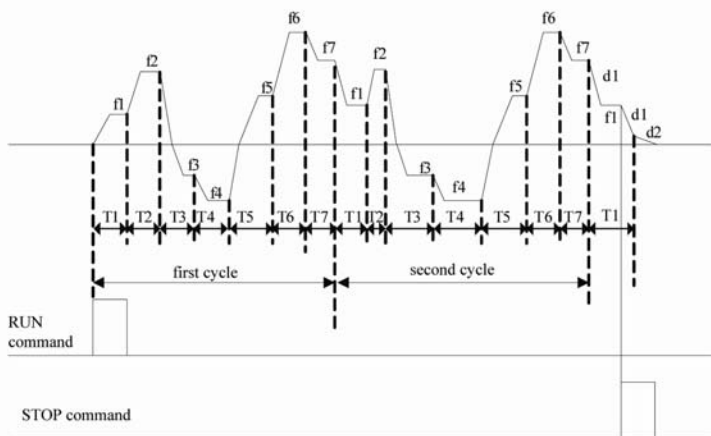

Fig.6-27 Diagram of PLC Continuous Cycle

2: maintain final value after single cycle

Inverter automatically maintains running frequency and direction of final stage after one cycle completes, seen below:

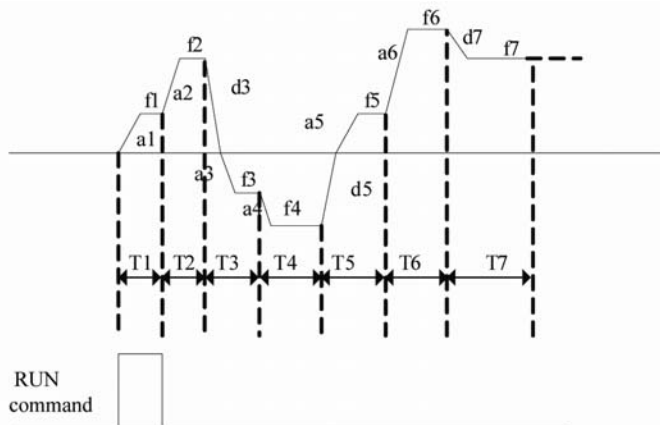

Fig.6-28 Diagram of Simple PLC Running

LED hundreds' digit: start method

0: start from the first stage

1: start from stop (fault) stage

When hundreds' digit is 1 (save), inverter starts from stop (fault) stage after powered on. When hundreds' digit is 0 (not save), inverter starts from the first stage after powered on.

2: start from stop (fault) stage and frequency

When thousands' digit is 1 (save), inverter starts at frequency and running time of stop (fault) stage after powered on. When thousands' digit is 0 (not save), inverter starts from the first stage after powered on.

LED thousands' digit: power-down save selection

0: not save

PLC running status is not memorized if power down. Inverter starts from the first stage after powered on.

1: save

PLC running status is memorized if power down, including stage, running frequency and running time. Inverter starts and goes into this stage after powered on. It continues running at frequency defined at this stage and residual running time.

F8.01	Multi-speed frequency 1	
	-upper limit frequency~upper limit frequency	5.0
F8.02	Multi-speed frequency 2	
	-upper limit frequency~upper limit frequency	10.0
F8.03	Multi-speed frequency 3	
	-upper limit frequency~upper limit frequency	15.0
F8.04	Multi-speed frequency 4	
	-upper limit frequency~upper limit frequency	20.0
F8.05	Multi-speed frequency 5	
	-upper limit frequency~upper limit frequency	25.0
F8.06	Multi-speed frequency 6	
	-upper limit frequency~upper limit frequency	37.5
F8.07	Multi-speed frequency 7	
	-upper limit frequency~upper limit frequency	50.0

Multi-speed symbol decides running direction. Negative means reverse running. Frequency input is set by F0.02. Start and stop command is set by F0.01.

F8.08	Running time at stage 1	
	0.0~1000.0	10.0
F8.09	Running time at stage 2	
	0.0~1000.0	10.0
F8.10	Running time at stage 3	
	0.0~1000.0	10.0
F8.11	Running time at stage 4	
	0.0~1000.0	10.0
F8.12	Running time at stage 5	
	0.0~1000.0	10.0
F8.13	Running time at stage 6	
	0.0~1000.0	10.0
F8.14	Running time at stage 7	
	0.0~1000.0	10.0

It can set programmable multi-speed stage running time. Time unit is set by FC.04.

F8.15	Stage ACC/DEC time selection 1	
	0000~1111	0000

Unit's bit: ACC/DEC time at stage 1

0: ACC/DEC time1

1: ACC/DEC time2

Tens' digit: ACC/DEC time at stage 2

0: ACC/DEC time1

1: ACC/DEC time2

Hundreds' digit: ACC/DEC time at stage 3

0: ACC/DEC time1

1: ACC/DEC time 2

Thousands' digit: ACC/DEC time at stage 4

0: ACC/DEC time1

1: ACC/DEC time 2

F8.16	Stage ACC/DEC time selection 2	
	000~111	000

Unit's bit: ACC/DEC time at stage 5

0: ACC/DEC time1

1: ACC/DEC time2

Tens' digit: ACC/DEC time at stage 6

0: ACC/DEC time1

1: ACC/DEC time2

Hundreds' digit: ACC/DEC time at stage 7

0: ACC/DEC time1

1: ACC/DEC time2

Thousands' digit: retain **Tip:**

Time unit related to simple PLC is set in FC.04 parameter.

6.10 F9 Group- Protection Parameter

F9.00	Protection Setting	
	0000~1231	1001

LED unit's digit: motor overload protection selection

0: invalid

1: valid

Function code F9.01 is valid when this parameter is valid.

LED tens' digit: PID feedback disconnection action selection

0: no action

1: protection action and free stop

2: alarm and maintain running at frequency of disconnection

3: alarm and decelerate till zero speed

LED hundreds' digit: 485 communication failure action selection

0: protection action and free stop

1: alarm and maintain current running 2: alarm and stop

LED thousands' digit: input and output phase failure selection

0: invalid 1: input is valid and output is prohibited

2: input is invalid and output is valid 3: valid

 **Tip:**

1. Input phase failure protection is valid only when phase failure is input. When DC power is supplied through DC terminal, input phase failure protection will not act.

2. It is necessary to set reasonable detection benchmark when input phase failure protection is valid, or else wrong action may be caused.

F9.01	Motor overload protection coefficient	
	30%~110%	100%

Apply valid overload protection to motors of different types and loads. Reasonably set overload protection coefficient of motor. Limit allowed max. output current. It is percentage corresponding to inverter rated output current.

It is generally set as 100% when inverter drives motor with matched power class.

When inverter capacity is higher than motor capacity, to apply valid overload protection to load motor of different specification, it should reasonably set motor overload protection coefficient, shown below:

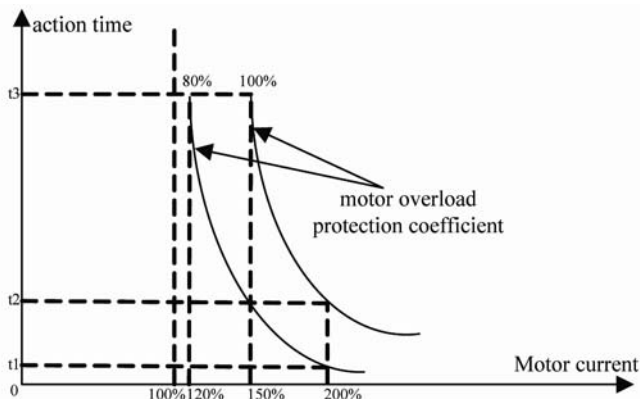

Fig.6-29 Diagram of Motor Overload Protection Curve

Voltage overload protection coefficient is decided by the equation below:

Motor load protection coefficient = allowed max. load current / inverter rated output current × 100%

Generally, max. load current means rated current of load motor.

F9.02	Under-voltage protection level	
	180~280/300~480V	200/380

Specify lower-limit voltage allowed by DC bus when inverter works as normal.

F9.03	Overvoltage limiting level	
	350~380/660~760V	380/740

Define action voltage when overvoltage stall protection.

F9.04	Current limiting level	
	100%~220%	Type setting

Define current threshold of automatic current limiting action. It is percentage corresponding to inverter rated current. If load is too heavy, it can increase limit level properly, allowing motor accelerate smoothly.

F9.05	Speed tracking current limiting level	
	100%~220%	Type setting

It automatically limits current during speed tracking. When actual current reaches this threshold (F9.05), inverter will reduce frequency and limit current, keep tracking and acceleration. It is percentage corresponding to inverter rated current.

F9.06	Feedback disconnection detection value	
	0.0~100.0%	0.0%

Max. PID assignment quantity is used as upper limit of feedback disconnection detection value. When feedback disconnection detection is made, PID feedback value is lower than feedback disconnection detection value, inverter will make protection action based on F9.00 setting. When F9.06=0.0%, it is invalid.

F9.07	Feedback disconnection detection time	
	0.1~1000.0	10.0

Delay time before protection action when feedback disconnects. Time unit is set by FC.04.

F9.08	Output phase failure and current imbalance detection threshold	
	10.0~100.0%	50.0%

If output current is lower than inverter rated current *F9.08, inverter will not execute output phase failure protection and output current imbalance detection. It is used to avoid wrong action or too sensitive action.

F9.09	Output current imbalance detection coefficient	
	1.00~10.00	1.00

If the ratio between max. value and min. value in three-phase output current is higher than this coefficient, lasts more than 10 seconds, the inverter will send output current imbalance fault E-22. When F9.09=1.00, output current imbalance detection is invalid.

6.11 FA Group-Supplementary Function Parameter

FA.00	Energy consumption brake starting voltage	
	340~380/660~760V	360/700
FA.01	Energy consumption brake action ratio	
	10~100%	100%

The above function code sets voltage threshold of brake unit acting inside inverter, return difference voltage value and braking unit utilization rate. If inverter DC side voltage is

higher than energy consumption brake starting voltage, built-in brake unit will act. If brake resistor is connected, the brake resistor will release pump voltage energy inside inverter, reducing DC voltage. When DC side voltage reduces till one value (starting voltage-brake return difference), built-in brake unit will close. Brake return difference is 6% of energy consumption brake starting voltage (FA.00).

FA.02	Cooling fan control	
	0~1	0

0: automatic control mode

Keep running when inverter runs. The fan stops when inverter stops and radiator temperature is below 40°C.

1: keep running when being energized

This mode is suitable to situation where some fans can not stop.

FA.03	Fault automatic reset times	
	0~10, 0 means invalid and 10 means time is not limitless.	0
FA.04	Fault automatic reset interval	
	0.5~25.0s	3.0

If fault occurs, inverter stops output and shows fault code. Through reset interval setting in FA.04, inverter will automatically reset fault and restart.

Times of fault automatic reset is set by FA.03. When it sets 0, automatic reset is not available. Need manual reset (STOP/RESET).

FA.05	Waiting time of restart upon power failure	
	0.0~25.0s	0.0

Any running command entered during waiting time for restart is invalid. If enter stop command, inverter will automatically release speed tracking restart status and return normal stop status.



Note:

This parameter will cause unexpected motor start, possibly resulting in potential injury to equipment and personnel. Be cautious.

FA.06	Overtorque check action	
	0~4	0
FA.07	Overtorque check value	
	0~200%	150%
FA.08	Overtorque check time	
	0.0~10.0S	0.0

When actual torque is FA.08 value (torque check time) and higher than FA.07 (overtorque check level), inverter will act accordingly according to FA.06 setting. 100% overtorque check level is corresponding to motor rated output torque.

0: invalid

No torque is tested.

1: Test during constant speed running. Continue output after overtorque is tested.

Only test whether it is overtorque during constant speed running. Continue running after overtorque is tested.

2: Test during constant speed running. Stop after overtorque is tested.

Only test whether it is overtorque during constant speed running. Stop running after overtorque is tested. Motor stops.

3: Test during constant speed running or deceleration running. Continue output after overtorque is tested.

Only test whether it is overtorque during constant speed running or acceleration. Continue running after overtorque is tested.

4: Test during constant speed running or deceleration running. Stop output after overtorque is tested.

Only test whether it is overtorque during constant speed running or acceleration. Stop output after overtorque is tested. Motor stops

FA.09	Energy saving control function	
	0~16	0

Closed when set as 0. Bigger value will get obvious effect of energy saving. However, instability may be caused.

FA.10	Magnetic flux braking function	
	0~10	0

Adjust the ability in magnetic flux braking during deceleration. Bigger value will make this ability stronger. It is not necessary to set this code when deceleration time is very short. Invalid when set as 0.

FA.11	Frequency drop rate upon no instantaneous stop	
	0.1~100.0Hz/S	0.0

When bus voltage is 80% lower than benchmark voltage (538V), reduce frequency properly based on this code. Maintain inverter not trip in short time by using load feedback energy. Invalid when set as 0.

FA.12	AVR function	
	0~2	2

0: prohibit

1: valid in whole course

2: only invalid for deceleration

AVR is voltage automatic adjustment function. When inverter output voltage differs from rated value, this function can keep output voltage constant, avoiding overvoltage. It is invalid when output command voltage is higher than input voltage. In deceleration, if AVR does not act, deceleration will last short with bigger running current. If AVR acts, motor decelerates smoothly with smaller running current and longer deceleration time.

FA.13	Speed tracking start waiting time	
	0.00~100.00S	1.00

FA.14	Count and timing mode	
	0000~0303	0

LED unit's digit: treatment of reaching count

0: single week count, stop output

1: single week count, continue output

2: cycle count, stop output

3: cycle count, continue output

Inverter will act accordingly when reaching F5.16 value.

LED tens' digit: retain

LED hundreds' digit: treatment of reaching timing

0: single week timing, stop output

1: single week timing, continue output

2: cycle timing, stop output

3: cycle timing, continue output

Inverter will act accordingly when reaching F5.18 value.



LED thousands' digit: retain

FA.15	Retain	
	retain	0
FA.16	Running limiting function password	
	0~65535	0

Default is 0. Set FA.17 and FA. 18 only when password is validated to be correct.

If running limiting function password is not required, set it as 0.

To set running limiting password, enter any non-zero data. Press  to confirm. Password is valid after one minute.

To change password, select FA.16, press  to enter password validation. After it succeeds, enter modification status. Enter new password and press  to confirm. Password is valid after one minute. To clear password, set running limiting password as "00000".

FA.17	Running limiting function selection	
	0~1	0

0: invalid

1: valid

When this code is valid, cumulative running time of inverter exceeds FA.18 time, running limiting function will act, inverter stops and operation panel shows E-21. To clear the fault, correctly validate FA.16 (running limiting password) and set FA.17 (running limiting function selection) as "0"(invalid).

FA.18	Run limiting time	
	0~65535 (h)	0

Refer to FA.17 description.

6.12 FB Group- Communication Parameter

FB.00	Local machine address	
	0~247 0 is broadcast address.	1

FB.01	MODBUS communication configuration	
	0000~2231	0120

LED unit's digit: protocol selection

0: RTU

1: retain

LED tens' digit: baud rate selection

0: 4800BPS

1: 9600BPS

2: 19200BPS

3: 38400BPS

It defines data transmission rate between upper computer and inverter. They should have same baud rate, or else communication will fail. The higher baud rate is, the quicker data communication will be. Baud rate too high will affect communication stability.

LED hundreds' digit: data format

0: no check

1: even check

2: odd check

Upper computer has data format consistent to that of inverter, or else communication can not work.

LED thousands' digit: communication response method

0: normally respond

1: only respond slave machine's address

2: not respond

FB.02	Communication timeout check time	
	0.1~100.0s	10.0

If it exceeds interval defined in this code, no correct data signal is received, the local

machine will regard communication fails, inverter will set communication failure action to decide whether protect or maintain running. When it is set as 0.0, RS485 communication timeout check will not be made.

FB.03	Local machine answer delay	
	0~200ms	5

Define interval from receiving data frame by the inverter to send answer data frame to upper computer. If answer time is less than system handling time, system handling time will prevail.

FB.04	Proportional correlation coefficient	
	0.1~10.00	1.00

Define weight coefficient of frequency command received by the inverter as slave machine from RS485 port. Actual running frequency is equal to this function code multiplying frequency setting command value received at RS485 port. In correlation control, this function code can set the proportion of running frequency for multiple inverters.

6.13 FC Group-Monitoring and Display Parameters

FC.00	Running monitoring parameter item selection	
	0~20	0

By changing this value, it can change monitoring item in main monitoring interface. For example: FC.00=2 means to select output voltage (D-02), so the default display item in main monitoring interface is current output voltage value.

FC.01	Stop monitoring parameter item selection	
	0~20	1

By changing this value, it can change monitoring item in main monitoring interface. For example: FC.00=3 means to select bus voltage (D-03), so the default display item in main monitoring interface is current bus voltage value.

FC.02	Motor speed indication coefficient	
	0.01~10.00	1.00

Correct speed scale error, do not affect actual speed.

FC.03	Close-loop indication coefficient	
	0.01~10.00	1.00

Correct the error between actual physical quantity (pressure, flow, etc) in close-loop control mode and assigned or feedback quantity (voltage and current), do not affect close-loop adjustment.

FC.04	Time unit selection	
	000~111	000

LED unit's digit: process PID time unit

0: second

When it is selected, time unit in F7.10、F7.13、F7.14 and F9.07 is second.

1: minute

When it is selected, time unit in F7.10、F7.13、F7.14 and F9.07 is minute. LED tens' digit: simple PLC time unit

0: second

When it is selected, time unit in F8.08~F8.14 is second.

1: minute

When it is selected, time unit in F8.08~F8.14 is minute.

LED hundreds' digit: routine ACC/DEC time unit

0: second

When it is selected, time unit in F0.10、F0.11、F1.13 和 F1.14 is second.

1: minute



When it is selected, time unit in F0.10、F0.11、F1.13 和 F1.14 is minute.

FC.05	User password	
	0~65535	0

It prohibits function parameter is checked and modified by unauthorized personnel.

To avoid wrong operation, password less than 10 is invalid.

When user password is set, enter any number no less than 10, press  to confirm. Password is valid after one minute.

If to modify, select FC.00, press  to enter password validation. After it succeeds, enter modification, enter new password, and press  to confirm. Password is automatically valid after one minute.

Keep password properly. If forget, seek for manufacturer's service.



FC.06	Inverter power specification	
	0.10~655.35KW	Type setting
FC.07	Main controller software version	
	1.00~99.99	1.00

It indicates inverter related information, only for check, not changeable.

Chapter 7 Fault Diagnosis and Troubleshooting

7.1 Fault Inquiry

In case of fault during running, the inverter will block PWM input and enter fault protection. The fault code flashing shows current fault information. Fault indicator lamp ALM turns on.

Working conditions (e.g. output frequency, setting frequency, output current, DC bus voltage, running status, module temperature etc) occurring faults and latest three faults are shown by function code d-21~d-28, which are inquired by 、 key, shown in Table 7-1.

Function Code	Code Content
d-21	Third fault code
d-22	Second fault code
d-23	Latest fault code
d-24	Inverter status in last two faults
d-25	Output frequency in last two faults (Hz)
d-26	Output current in last two faults (A)
d-27	Bus voltage in last two faults (V)
d-28	Module temperature in last two faults (°C)
d-29	Inverter status in latest fault
d-30	Output frequency in latest fault (Hz)
d-31	Output current in latest fault (A)
d-32	Bus voltage in latest fault (V)
d-33	Module temperature in latest fault (°C)

Table 7-1 Fault Code Inquiry

**Note:**

- Regardless fault occurs or not, the user can inquire fault by using keyboard when the inverter works under parameter setting status. Details refer to the above table.
- Any operation below can clear fault status when fault is inquired:
 - Press "Stop/Reset".
 - Short-circuit RST function terminal with COM terminal and release.

7.2 Fault Code

Fault Code	Name	Possible Reasons	Countermeasures
E-01	Over-current in accelerated run	Too short acceleration (including tuning)	Extend acceleration time.
		Restart motor running	Start after set as DC brake or speed tracking start.
		Too small power in inverter	Select inverter with bigger power.
		V/F curve or torque lifting setting is improper.	Adjust V/F curve or torque lifting quantity.
E-02	Over-current in decelerated run	Too short deceleration (including tuning)	Extend deceleration time.
		Small power in inverter	Select inverter with bigger power
		Too big load inertia	Connect to brake resistor or brake unit.
E-03	Over-current in constant-speed run	Low voltage in grid.	Check input power supply
		Load changes suddenly or is abnormal	Check the load or reduce load sudden change
		Too small power in inverter	Select inverter with bigger power
E-04	Overvoltage in accelerated run	Input voltage is abnormal (including tuning)	Check input power supply
		Restart motor that is rotating	Start after set as DC brake or speed tracking start.
		Special potential energy load	Connect to brake resistor or brake unit.
E-05	Overvoltage in decelerated run	Too short deceleration (including tuning)	Extend deceleration time
		Too big load inertia	Connect to brake resistor or brake unit.
		Input voltage is abnormal.	Check input power supply
E-06	Overvoltage in constant-speed run	Input voltage is abnormal.	Check input power supply
		Special potential energy load	Connect to brake resistor or brake unit.

E-07	Overvoltage upon shut-down	Input voltage is abnormal.	Check power supply and voltage.
E-08	Under-voltage when running	Input voltage is abnormal or contactor(relay) is not engaged.	Check power supply and voltage or seek for manufacturer's service.
E-09	Power module in fault	Inverter output is in short circuit or grounded.	Check wiring.
		Instant over-current in inverter	Refer to over-current countermeasures.
		Air duct is blocked or fan is damaged	Clean air duct or replace fan.
		Control panel is abnormal or disturbance is serious.	Seek for manufacturer's service.
		Power device is damaged.	Seek for manufacturer's service.
E-10	Overheating of radiator	Temperature is too high.	Reduce temperature .
		Fan is damaged.	Replace fan.
		Air duct is blocked.	Clean air duct.
E-11	Inverter overload.	V/F curve or torque lifting setting is improper.	Adjust V/F curve or torque lifting quantity.
		Too low voltage in grid.	Check grid voltage.
		Too short deceleration	Extend acceleration time
		Too heavy load in motor.	Select inverter with bigger power.
E-12	Motor overload.	V/F curve or torque lifting setting is improper.	Adjust V/F curve or torque lifting quantity.
		Too low voltage in grid.	Check grid voltage.
		Motor stalling or load sudden change is too big.	Check load.
		Motor overload protection factor is wrongly set.	Correct it.
E-13	External device in fault	Fault input terminal of external equipment is closed.	Disconnect fault input terminal of external equipment and remove fault(check reasons).
E-14	Communication fault in co-processor	Communication is abnormal in main co-processor.	Seek for manufacturer's service.
E-15	PID feedback disconnection	feedback wire loosens.	Check feedback wire.
		Feedback quantity is less than disconnection test value.	Adjust test input threshold.
E-16	RS485 communication fault	Not matched with upper computer baud rate.	Adjust baud rate.
		Communication overtime.	Try again.

		RS485 signal channel disturbs.	Check communication wire is shielded or not, wiring is reasonable, consider and connect filter capacitor if necessary.
E-17	Motor tuning fault	Motor parameters are wrongly set.	Set motor parameters again.
		Inverter is not matched with motor power specification.	Seek for manufacturer's service.
		Tuning overtime.	Check motor wiring.
E-18	Current detection fault	Hall device or amplifying circuit is in fault.	Seek for manufacturer's service.
		Auxiliary power is in fault.	
		Hall or power plate wiring is in bad contact.	
E-19	EEPROM reading and writing fault	EEPROM fault	Seek for manufacturer's service.
E-20	Input phase failure fault	Power input phase failure.	Check power supply and wiring.
E-21	Running limit action	Reach running limit time.	Seek for dealer's service.
E-22	Output phase failure or current imbalance fault.	Output U, V and W phase failure.	Check output wiring.
E-00	No fault code.	NC	NC

Table 7-3 Fault Code

7.3 Abnormality Treatment

Abnormalities and countermeasures for inverter running are seen in Table 7-3.

Abnormality		Possible Reasons and Countermeasures
Motor does not run.	No indication in keyboard.	Check if there is power failure, input power lacks phase, input power cord is wrongly connected or not.
	No indication in keyboard but charging indicator lamp flashes.	Check whether wire and socket in keyboard fails. Measure control power voltage inside inverter to ensure switch power works normally. If it does not work, check switch power cord (+, -) and socket are connected, oscillation starting is damaged or stabilivolt is normal.
	Motor hums.	Too heavy load in motor. Reduce load.

No abnormality is found.	Confirm whether it is in trip status or not reset after trip, in restart status after power failure, keyboard is set again, it enters program running status, multi-speed running status, particular running or non-running status. Try to restore factory value.
	Confirm running command is given.
	Check running frequency is set as 0.
Motor can not accelerate or decelerate.	ACC/DEC time is improper. Extend ACC/DEC time.
	Current limiting value is too small. Increase limiting value.
	Ovoltage protection action when deceleration and extend deceleration time.
	Improper carrier frequency, too heavy load or oscillation occurs.
	Too heavy load and insufficient moment. Increase torque lifting value in V/F mode. If it still fails, change into automatic torque lifting mode (default in Smart). Pay attention that motor parameter should be consistent to actual value. If it still fails, it is recommended using magnetic flux vector control, making motor parameter consistent to actual value, and using motor parameter tuning.
	Motor power mismatches with inverter power. Set motor parameter as actual one.
	Change torque lifting method into manual lifting mode.
Motor can not adjust speed when rotating.	Upper and lower limit of frequency is improper.
	Frequency is too low or frequency gain is too low.
	Check speed adjustment method is consistent to given frequency.
	Check load is too heavy or not, in overvoltage stall or overcurrent limiting status.
Motor speed changes when running.	Load changes a lot. Try to reduce changes.
	Inverter mismatches with motor ratings. Set motor parameter as actual one.
	Frequency assignment potentiometer is in bad contact or frequency assignment signal fluctuates. Change into digital frequency assignment method or increase filter time constant of analog input signal.
Rotation in motor is opposite.	Adjust phase frequency of output terminal U, V and W.
	Set running direction (F0.09=1) as reverse.
	Output power lacks phase, leading to uncertain direction. Please check motor wiring.

Table 7-3 Abnormalities and Countermeasures

Chapter 8 Maintenance and Care

8.1 Daily Maintenance and Care

The changes of use environment of inverter, e.g. temperature, humidity and smoke, as well as aging components inside inverter will cause the inverter into faults of all kinds. Therefore, the inverter must be daily checked during storage and use, and periodically maintained and repaired.

8.1.1 Daily Maintenance

Please confirm the following items when inverter starts normally:

- (1) Whether motor sounds abnormally and vibrates;
- (2) Whether inverter and motor is heat abnormally;
- (3) Whether temperature is too high;
- (4) Whether load current value is the same as usual;
- (5) Cooling fan in inverter runs normally.

8.2 Periodic Maintenance and Care

8.2.1 Periodic Maintenance

Power supply must be cut off when inverter is periodically maintained and checked. Check only when the monitor has no display and power indication lamp of main circuit turns off. Check contents are seen in Table 8-1.

Table 8-1 Periodic Check Contents

Check Items	Check Contents	Countermeasures
Screw in main circuit terminal and control circuit terminal	Whether it is loose	Screw tightly with screwdriver
Radiating piece	Whether air duct is blocked by dust and foreign material	Blow off the air duct with dry compressed air under pressure 4~6kg/cm ²
PCB	Whether its surface has oil sludge and conductor debris or copper foil is corrosive.	Remove foreign material from surface of PCB.
Cooling fan	Whether it runs normally. Whether it sounds or vibrates abnormally. Cumulative running time reaches 20,000 hours above.	Replace cooling fan
Power component	Whether it has dust and oil sludge.	Remove foreign material
Electrolytic capacitor	Whether it leaks or bubbles appear. Anti-explosion valve is not extruded or not.	Replace electrolytic capacitor.

8.2.2 Periodic Care

To realize longer lifespan of inverter, the electronic components inside inverter must be periodically maintained and repaired according to their lifespan. The lifespan of electronic component inside inverter varies with the use environment and use condition. The maintenance period of inverter, as shown in Table 8-2 is only for reference to users when they are using.

Table 8-2 Replacement Time of Inverter Components

Component	Standard Replacement Year
Cooling fan	2~3 years
Electrolytic capacitor	4~5 years
Printed circuit board	5~8 years
Fuse protector	10 years

The use condition of inverter components to be replaced above are :

- (1) Environmental temperature: averaged annual temperature is 30°C.
- (2) Load factor: below 80%
- (3) Running time: below 12 hours every day.

8.3 Guarantee for Inverter

Our company will offer warranty service to the inverter in following cases:

- (1) Warranty scope only covers inverter body.
- (2) Our company is responsible for repairing the inverter that is caused damage or failure within 12 months under normal use and charge reasonable maintenance expense if it exceeds 12 months.
- (3) We will charge maintenance expense in following cases within 1 months:
 - The inverter is caused damage due to operation in violation of operation segments described in user manual;
 - The inverter is caused damage due to flood, fire and abnormal voltage, etc.
 - The inverter is caused damage due to wiring error, etc.
 - The inverter is caused damage due to its application into non-normal function.
- (4) Service fee will be calculated according to actual expense. If contract is signed, the contract will prevail.

— Annex —

— Communication Protocol —

9.1 RTU Mode and Format

When controller communicates in Modbus bus in RTU mode, every 8-bit byte will be divided into 2 4-bit hexadecimal characters. Its advantage lies in the density of transmitted characters is higher than ASCII mode at same baud rate, and each information must be continuously transmitted.

(1) Format of each byte in RTU mode

Code system: 8 binary bits, hexadecimal 0-9, A-F.

Data bit: 1 starting bit, 8 data bits (lower bit is transmitted first), 1 stop bit, odd-even check bit is available (Refer to RTU data frame sequence diagram).

Error check area: cyclic redundancy check(CRC).

(2) RTU data frame sequence diagram

With odd-even check

Start	1	2	3	4	5	6	7	8	Par	Stop
-------	---	---	---	---	---	---	---	---	-----	------

Without odd-even check

Start	1	2	3	4	5	6	7	8	Stop
-------	---	---	---	---	---	---	---	---	------

9.2 Smart Register Address and Function code

(1) Supported function codes

Function code	Function Description
03	Read multiple registers
06	Write single register
10	Write multiple registers in successive way

(2) Register address

Register Function	Address
Input control command	0x2000
Read monitoring parameter	0x1000~0x101C
Set MODBUS frequency	0x2001
Parameter setting	0x0000~0x0F0F

(3) 03H read multiple parameters (8 parameters are read successively at maximum.)

Inquiry information frame format (Forward frame) :

Address	01H
Function	03H
Starting data address	00H
	01H
Number of Data(Byte)	00H
	02H
CRC CHK High	95H
CRC CHK Low	CBH

Such data analyzes:

01H	inverter address
03H	reading function code
0001H	F0.01 item whose starting address is same to control panel
0002H	read number of menu items, namely F0.01 item and F0.02 item
95CBH	16-bit CRC check code

Response information frame format (Return frame) :

Address	01H
Function	03H
DataNum*2	04H
Data1[2Byte]	00H
	00H
Data2[2Byte]	00H
	00H
CRC CHK High	FAH
CRC CHK Low	33H

Such data analyzes:

01H	inverter address
03H	reading function code
04H	product that read item*2
00 00H	F0.01 item data
00 00H	F0.02 item data
FA 33H	16-bit CRC check code

Example:

Name	Frame Format
Read F0.01 item and F0.02 item data	Forward frame: 01H 03H 0001H 0002H 95CBH
	Return frame: 01H 03H 04H 0000H 0000H FA33H
Read F2.00 item data	Forward frame: 01H 03H 0200H 0001H 85 B2H
	Return frame: 01H 03H 02H 0000H B844H
Read monitoring parameter in d-00 item	Forward frame: 01H 03H 1000H 0001H 80CAH
	Return frame: 01H 03H 02H 01F4H B853H

(4) 06H write single parameter

Inquiry information frame format (Forward frame) :

Address	01H
Function	06H
Starting data address	20H
	00H
Data(2Byte)	00H
	01H
CRC CHK Low	43H
CRC CHK High	CAH

Such data analyzes:

01H	inverter address
06H	writing function code
2000H	control command address
0001H	forward command
43A1H	16-bit CRC check code

Response information frame format (Return frame) :

Address	01H
Function	06H
Starting data address	20H
	00H
Number of Data(Byte)	00H
	01H
CRC CHK High	43H
CRC CHK Low	CAH

Such data analyzes: If setting is right, return same input data.

Example:

Name	Frame Format
Forward	Forward frame: 01H 06H 2000H 0001H 43CAH
	Return frame: 01H 06H 2000H 0001H 43CAH
Reverse	Forward frame: 01H 06H 2000H 0009H 420CH
	Return frame: 01H 06H 2000H 0009H 420CH
Stop	Forward frame: 01H 06H 2000H 0003H C20BH
	Return frame: 01H 06H 2000H 0003H C20BH
Free stop	Forward frame: 01H 06H 2000H 0004H 83C9H
	Return frame: 01H 06H 2000H 0004H 83C9H
Reset	Forward frame: 01H 06H 2000H 0010H 43CAH
	Return frame: 01H 06H 2000H 0010H 43CAH
Forward jog	Forward frame: 01H 06H 2000H 0002H 03CBH
	Return frame: 01H 06H 2000H 0002H 03CBH
Reverse jog	Forward frame: 01H 06H 2000H 000AH 020DH
	Return frame: 01H 06H 2000H 000AH 020DH
Set parameter in F8.00 item as 1	Forward frame: 01H 06H 0800H 0001H 4A6AH
	Return frame: 01H 06H 0800H 0001H 4A6AH
MODBUS given frequency is 40HZ.	Forward frame: 01H 06H 2001H 0190H D236H
	Return frame: 01H 06H 2001H 0190H D236H

(5) 10H continuously write multiple parameters

Inquiry information frame format (Forward frame) :

Address	01H
Function	10H
Starting data address	01H
	00H
Number of Data(Byte)	00H
	02H
DataNum*2	04H
Data1(2Byte)	00H
	01H
Data2(2Byte)	00H
	1EH
CRC CHK High	2FH
CRC CHK Low	F7H

Such data analyzes:

01H	inverter address
10H	writing function code
0100H	F1.01 item whose starting address is same to control panel
0002H	number of registers
04H	total number of bytes (2*number of registers)
0001H	F1.00 item data
001EH	F1.01 item data
2FF7H	16-bit CRC check code

Response information frame format (Return frame) :

Address	01H
Function	10H
Starting data address	01H
	00H
Number of Data(Byte)	00H
	02H
CRC CHK High	40H
CRC CHK Low	34H

Such data analyzes:

01H	inverter address
10H	writing function code
0100H	write F1.00 item data
0002H	number of registers, namely writing parameter F1.00 and F1.01
4034H	16-bit CRC check code

Example:

Name	Frame Format
Set F1.00 and F1.01 parameter as 1 and 3.0 respectively	Forward frame: 01H 10H 0100H 0002H 04H 0001H 001EH 2FF7H
	Return frame: 01H 10H 0100H 0002H 4034H
Forward running and set communication assignment frequency as 50HZ	Forward frame: 01H 10H 2000H 0002H 04H 0001H 01F4H 3BB9H
	Return frame: 01H 10H 2000H 0002H 4A08H
Set F1.00 item parameter as 1	Forward frame: 01H 10H 0100H 0001H 02H 0001H 7750H
	Return frame: 01H 10H 0100H 0001H 0035H

9.3 Control Command Character Format (Refer to example of function code write 06H)

Address	Bit	Meaning
2000H	Bit7~Bit5	Retain
	Bit4	0: no action 1: reset
	Bit3	0: forward 1: reverse
	Bit2~Bit0	100: free stop 011: stop 010: jog run 001: run

9.4 Communication address corresponding to all parameters

Function code	Communication Address
F0.00~F0.15	0000H~000FH
F1.00~F1.18	0100H~0112H
F2.00~F2.08	Co0200H~0208H
F3.00~F3.07	0300H~0307H
F4.00~F4.07	0400H~0407H
F5.00~F5.22	0500H~0516H
F6.00~F6.19	0600H~0613H
F7.00~F7.14	0700H~070EH
F8.00~F8.16	0800H~0810H
F9.00~F9.09	0900H~0909H
FA.00~FA.19	0A00H~0A13H
FB.00~FB.04	0B00H~0B04H
FC.00~FC.07	0C00H~0C07H
FF.00~FF.15	0F00H~0F0FH
d-00~d-28	1000H~101CH

9.5 Error Code Meaning of Abnormal Information responded by Slave Machine

Error Code	Description
01H	Illegal function code
02H	Illegal address
03H	Illegal data
04H	Length of illegal register
05H	CRC check error
06H	Parameter can not be changed during running
07H	Parameter can not be changed
08H	Upper computer control command invalid
09H	Parameter is protected by password.
0AH	Password error

 **Note:**

- 1、 In above examples, the inverter address is set as 1 for convenient description. When inverter is slave machine, its address is set between 1-247. If any data in frame format is changed, check error must be counted again. Download CRC16-bit check code calculator from network.
 - 2、 Starting address of monitoring item is 1000, and then offset corresponding hexadecimal value every item and plus it with starting address. Example: monitoring start item is d—00, starting address is 1000H, now, read monitoring item d—18, **18-00**=18, among which, 18 is converted into 12H, so the reading address of d—18 is 1000H+12H = 1012H.
 - 3、 Frame format when information responded by slave machine is abnormal: inverter address + (80H+function code) + error code + 16-bit CRC check code. If return frame of slave machine is 01H + 83H + 04H + 40F3H, 01H is slave machine address, 83H is 80H+03H, meaning reading error, 04H means illegal data length, and 40F3H is 16-bit CRC check code.
-

Annex 2

Applied Situations and Related Parameters Setting

Speed tracking

Before motor freely running stops, restart can be made without stopping. Inverter automatically searches motor speed and accelerate when their speeds are the same.

Applied Situation	Applied Purpose	Related Parameter
Inertia load like windmill and spooling equipment	Smoothly start motor running freely	F1.00、F9.05、FA.13

DC braking before start

If motor freely running runs at uncertain direction, conduct DC braking before start.

Applied Situation	Applied Purpose	Related Parameter
Loads possibly moving when windmill and pump stops	Start motor freely running	F1.03、F1.04

Multi-speed running

Control seven speeds through simple node signal.

Applied Situation	Applied Purpose	Related Parameter
Transmission machine	Periodically run through multistage preset frequency	F5.00~F5.06、F8.01~F8.07

Switch running during multi-speed ACC/DEC time

Switch multistage ACC/DEC running through external signal. When more than two motors are driven by one inverter, this function can switch high-speed running into start/stop.

Applied Situation	Applied Purpose	Related Parameter
Automatic turntable of transmission machine	Switch ACC/DEC time through external signal	F0.10、F0.11、F1.13、F1.14、F5.00~F5.06

Running command selection

Select inverter is controlled by external terminal or operation panel.

Applied Situation	Applied Purpose	Related Parameter
General situation	Select control signal source	F0.01、F5.00~F5.06

Frequency holding running

Hold output frequency when inverter accelerates and decelerates.

Applied Situation	Applied Purpose	Related Parameter
General situation	ACC/DEC pause	F5.00~F5.06

Automatic restart after abnormality

When fault occurs, the inverter will restart according to reset times, automatic reset fault status and starting method.

Applied Situation	Applied Purpose	Related Parameter
Air-conditioner	Promote running continuity and reliability	F1.00 hundreds' bit, FA.03、FA.04、FA.05

DC braking stop

If brake resistor is not mounted in inverter, DC braking can be used to stop motor.

Applied Situation	Applied Purpose	Related Parameter
High-speed shaft	Motor suddenly stops when brake resistor is not mounted.	F1.05~F1.08

Over-torque setting

Motor or mechanical over-torque value can be set inside inverter. When over-torque occurs, it will adjust output frequency. It is suitable for wind and hydraulic machine running without trip.

Applied Situation	Applied Purpose	Related Parameter
Pump, fan and extruder	Protect machinery and promote running continuity and reliability	FA.06~FA.08

Frequency upper-limit and lower-limit running

Adjust inverter parameters when external running signal can not offer upper-limit and lower-limit, gain and bias.

Applied Situation	Applied Purpose	Related Parameter
Pump and fan	Control motor speed within upper and lower limit	F0.07~F0.08

Carrier frequency setting

Adjust inverter carrier frequency to reduce motor metal noise.

Applied Situation	Applied Purpose	Related Parameter
General situation	Reduce noise	F0.12、F4.00 hundreds' bit

Signal output during running

Inverter sends one signal when motor runs and releases mechanical brake(it disappears when inverter freely runs).

Applied Situation	Applied Purpose	Related Parameter
General situation: working machine	Provide running status signal	F5.11~F5.12

Signal output at zero speed

Signal will be sent when inverter output frequency is lower than lower limit, offered to external system or control line.

Applied Situation	Applied Purpose	Related Parameter
General situation: working machine	Provide running status signal	F5.11~F5.12

Signal output for designated frequency arriving

Signal will be sent when inverter output frequency arrives at designated frequency, offered to external system or control line.

Applied Situation	Applied Purpose	Related Parameter
General situation: working machine	Provide running status signal	F5.11~F5.12

Over-torque signal output

When over-torque occurs in motor and torque exceeds setting value in inverter, signal will be sent to avoid mechanical load from damage.

Applied Situation	Applied Purpose	Related Parameter
Working machine, fan, pump and extruder	Mechanical protection. Promote running reliability.	F5.11~F5.12、FA.06~ FA.08

Signal output for any frequency arriving

Signal will be sent when inverter output frequency arrives at designated frequency, offered to external system or control line.

Applied Situation	Applied Purpose	Related Parameter
General situation; working machine	Provide running status signal	F5.14、F5.15

Multi-functional analog output

Show inverter running frequency or output current, voltage. Frequency meter, voltmeter and current meter are available.

Applied Situation	Applied Purpose	Related Parameter
General situation	Display running status and information.	F6.16~F6.19



EASYDRIVE® Shenzhen Easydrive Electric Co., Ltd.

Warranty Agreement

1. Warranty scope only covers inverter body.
2. Our company is responsible for repairing the inverter that is caused damage or failure within 18 months under normal use and charge reasonable maintenance expense if it exceeds 12 months.
3. Warranty period will be valid since the shipment date from our company.
4. We will charge maintenance expense in following cases within 12 months:
 - The inverter is caused damage due to operation in violation of operation segments described in user manual;
 - The inverter is caused damage due to flood, fire and abnormal voltage, etc.
 - The inverter is caused damage due to wiring error, etc.
 - The inverter is caused damage due to its application into non-normal function.
5. Service fee will be calculated according to actual expense. If contract is signed, the contract will prevail.
6. Please keep this card in good condition and show it to maintenance unit upon warranty.
7. If there is any question, you can contact with the dealer and directly contact with our company.

Address: Building 11, Jingxuan Industrial Park, Donghuan 2 Road,
Longhua, Baoan District, Shenzhen

Postcode: 518112 Fax: 82447815

<http://www.szeasydrive.com>

SMART Inverter Warranty Bill

User Company:	
Detailed Address:	
Postcode:	Contact Person:
Tel:	Fax:
Machine No.:	
Power:	Machine Model:
Contact No.:	Purchase Date:
Service Unit:	
Contact Person:	Tel:
Maintenance Personnel:	Tel:
Maintenance Date:	
User Opinions and Evaluation: <input type="checkbox"/> Very Good <input type="checkbox"/> Good <input type="checkbox"/> Normal <input type="checkbox"/> Bad	
Other Opinions:	
User Signature:	Date:
Return-visit Record of company:	
Others:	