



**CONTROL
TECHNIQUES**

www.controltechniques.com



Advanced User Guide

Commander SK

AC variable speed drive for 3
phase induction motors from
0.25kW to 4kW, 0.33hp to 5hp

Part Number: 0472-0001-02

Issue: 2

General Information

The manufacturer accepts no liability for any consequences resulting from inappropriate, negligent or incorrect installation or adjustment of the optional parameters of the equipment or from mismatching the variable speed drive with the motor.

The contents of this guide are believed to be correct at the time of printing. In the interests of commitment to a policy of continuous development and improvement, the manufacturer reserves the right to change the specification of the product or its performance, or the content of the guide without notice.

All rights reserved. No parts of this guide may be reproduced or transmitted in any form or by any means, electrical or mechanical including, photocopying, recording or by an information storage or retrieval system, without permission in writing from the publisher.

Drive software version

This product is supplied with the latest version of user-interface and machine control software. If this product is to be used in a new or existing system with other drives, there may be some differences between their software and the software in this product. These differences may cause the product to function differently. This may also apply to drives returned from the Control Techniques Service Centre.

If there is any doubt, please contact your local Control Techniques Drive Centre or Distributor.

Environmental Statement

Control Techniques is committed to minimising the environmental impacts of its manufacturing operations and of its products throughout their life cycle. To this end, we operate an Environmental Management System (EMS) which is certified to the International Standard ISO 14001. Further information on the EMS, our Environment Policy and other relevant information is available on request, or can be found at www.greendrives.com.

The electronic variable speed drives manufactured by Control Techniques have the potential to save energy and (through increased machine/process efficiency) reduce raw material consumption and scrap throughout their long working lifetime. In typical applications, these positive environmental effects far outweigh the negative impacts of product manufacture and end-of-life disposal.

Nevertheless, when the products eventually reach the end of their useful life, they can very easily be dismantled into their major component parts for efficient recycling. Many parts snap together and can be separated without the use of tools, while other parts are secured with conventional screws. Virtually all parts of the product are suitable for recycling.

Product packaging is of good quality and can be re-used. Large products are packed in wooden crates, while smaller products come in strong cardboard cartons which themselves have a high-recycled fibre content. If not re-used, these containers can be recycled. Polythene, used on the protective film and bags from wrapping product, can be recycled in the same way. Control Techniques' packaging strategy favours easily recyclable materials of low environmental impact, and regular reviews identify opportunities for improvement.

When preparing to recycle or dispose of any product or packaging, please observe local legislation and best practice.

Contents

1	Introduction	4
2	Parameter x.00	5
2.1	Saving parameters	5
2.2	Loading default parameters	5
2.3	EUR/USA parameter set differences	5
3	Parameter description format	6
3.1	Software variable maximum term definitions	6
3.2	Parameter information	6
3.3	Key to parameter codes	7
3.4	Sources and destinations	8
3.5	Sample/update times	9
4	Keypad and display	10
4.1	Programming keys	10
4.2	Control keys	10
4.3	Selecting and changing parameters	10
5	CT Modbus RTU	12
6	User programming (PLC Ladder logic programming)	13
7	CT Soft	15
8	Menu 0	16
9	Advanced parameter descriptions	19
9.1	Overview	19
9.2	Menu 1: Speed reference selection, limits and filters	20
9.3	Menu 2: Ramps	31
9.4	Menu 3: Speed sensing thresholds and frequency input and output	40
9.5	Menu 4: Current control	45
9.6	Menu 5: Machine control	55
9.7	Menu 6: Drive sequencer and clock	66
9.8	Menu 7: Analog inputs and outputs	80
9.9	Menu 8: Digital inputs and outputs	87
9.10	Menu 9: Programmable logic, motorised pot and binary sum	94
9.11	Menu 10: Status logic and diagnostic information	104
9.12	Menu 11: General drive set-up	114
9.13	Menu 12: Programmable threshold and variable selector	127
9.14	Menu 14: PID controller	139
9.15	Menu 15: I/O Option parameters	145
9.16	Menu 18: Application menu 1	156
9.17	Menu 20: Application menu 2	158
9.18	Menu 21: Second motor map	159

1 Introduction

2 Parameter x.00

Pr x.00 is available in all menus and has the following functions:

- 1000** Save parameters
- 1070** Option reset

2.1 Saving parameters

When parameters are saved, all user save (US) parameters are saved to EEPROM within the drive. Normally Pr x.00 is set to 1000 and a reset command is given to initiate a parameter save. When parameter save is complete, Pr x.00 is reset to zero by the drive. The drive must not be in the under voltage (UU) condition for a save to take place. Saving parameter can take between 400ms and several seconds depending on the number of parameter values that are different from the values already saved in EEPROM. If the power is removed from the drive during a parameter save, it is possible for the EEPROM data to be corrupted giving an EEF failure when the drive is next powered up.

NOTE

Pr 11.42 parameter cloning modes 1 and 2, (rEAd and Prog) are not saved to EEPROM or the SmartStick.

2.2 Loading default parameters

When default parameters are loaded, the new default parameter set is automatically saved to the drive EEPROM.

2.3 EUR/USA parameter set differences

The following table gives the differences between the EUR and USA default parameters sets:

Pr	Description	EUR default	USA default	Voltage rating
1.06	Maximum set speed	50.0Hz	60.0Hz	All
2.08	Standard ramp voltage	750V	775V	400V
5.06	Motor rated frequency	50.0Hz	60.0Hz	All
5.08	Motor rated full load rpm	1500rpm	1800rpm	All
5.09	Motor rated voltage	400V	460V	400V
6.04	Start/Stop logic	0	4	All
21.01	Motor 2 maximum set speed	50.0Hz	60.0Hz	All
21.06	Motor 2 motor rated frequency	50.0Hz	60.0Hz	All
21.08	Motor 2 motor rated full load rpm	1500rpm	1800rpm	All
21.09	Motor 2 motor rated voltage	400V	460V	400V

3 Parameter description format

3.1 Software variable maximum term definitions

Table 3-1

Maximum	Definition
FREQ_MAX [1500.0Hz]	Maximum frequency reference FREQ_MAX = Pr 1.06 (If the second motor map is selected Pr 21.01 is used instead of Pr 1.06)
RATED_CURRENT_MAX [999.9A]	Maximum motor rated current RATED_CURRENT_MAX ≤ 1.36 x Rated drive current On drives that offer dual rating, the rated current can be increased above the rated drive current up to a level not exceeding 1.36 x drive rated current. The actual level varies from one drive size to another.
DRIVE_CURRENT_MAX [999.9A]	Maximum drive current The maximum drive current is the current at the over current trip level and is given by: DRIVE_CURRENT_MAX = rated drive current * 2
MOTOR1_CURRENT_LIMIT_MAX [999.9%]	Maximum current limit settings for motor map 1 This maximum current limit setting is the maximum applied to the current limit parameters in motor map 1. See introduction to section 9.5 <i>Menu 4: Current control</i> for the definition.
MOTOR2_CURRENT_LIMIT_MAX [999.9%]	Maximum current limit settings for motor map 2 This maximum current limit setting is the maximum applied to the current limit parameters in motor map 2. See introduction to section 9.5 <i>Menu 4: Current control</i> for the definition.
TORQUE_PROD_CURRENT_MAX [999.9%]	Maximum torque producing current This is used as a maximum for torque and torque producing current parameters. It is MOTOR1_CURRENT_LIMIT_MAX or MOTOR2_CURRENT_LIMIT_MAX depending on which motor map is currently active.
USER_CURRENT_MAX [999.9%]	Current parameter limit selected by the user The user can select a maximum for Pr 4.08 (torque reference) and Pr 4.20 (percentage load) to give suitable scaling for analog I/O with Pr 4.24 . This maximum is subject to a limit of CURRENT_LIMIT_MAX. USER_CURRENT_MAX = Pr 4.24
AC_VOLTAGE_SET_MAX [480V]	Maximum output voltage set-point Defines the maximum motor voltage that can be selected. 200V drives: 240V 400V drives: 480V
AC_VOLTAGE_MAX [618V]	Maximum AC output voltage This maximum has been chosen to allow for maximum AC voltage that can be produced by the drive including trapezoidal operation: AC_VOLTAGE_MAX = 0.7446 x DC_VOLTAGE_MAX 200V drives: 309V 400V drives: 618V
DC_VOLTAGE_SET_MAX [800V]	Maximum DC voltage set-point 200V rating drive: 0 to 400V 400V rating drive: 0 to 800V
DC_VOLTAGE_MAX [830V]	Maximum DC bus voltage The maximum measurable DC bus voltage. 200V drives: 415V 400V drives: 830V
POWER_MAX [999.9kW]	Maximum power in kW The maximum power has been chosen to allow for the maximum power that can be output by the drive with maximum a.c. output voltage, maximum controlled current and unity power factor. Therefore POWER_MAX = √3 x AC_VOLTAGE_MAX x RATED_CURRENT_MAX x 1.5

The values given in square brackets indicate the maximum value allowed for the variable maximum. The term 'rated drive current' is the value used by the software as rated current, which is not always the same as the drive rating specified in Pr **11.32** (see section 9.5 *Menu 4: Current control*).

3.2 Parameter information

3.2.1 Parameter x.00

Pr **x.00** in every menu is used for storing parameters. The range of this parameter is 4000 and the special codes used are as follows:

- 1000** Save parameters
- 1070** Option reset

3.2.2 Parameter types

There are two fundamental types of parameters in the drive, read only (RO) and read/write (RW). The read only parameters cannot be changed by the user and are there to give the user useful information about the state of the drive. Read/write parameters are for the user to set up the way in which the drive operates.

Parameters can be further broken down into Bit parameters and Non-bit parameters. Bit parameters are two state only (0 or 1) and if RW are used as switches or two state input variables to the drive logic, or if RO indicate various drive conditions which are either true (1) or false (0). Non-bit parameters have more than two values the range of each being given in the following descriptions.

In the basic parameter set, some parameters are represented as strings rather than numeric values which give a more informative indication of the parameter setting.

Since the parameters in the basic parameter set are copies of extended parameters, the strings are indicated as well as the numeric value. Setting-up via the serial interface requires numeric data.

Most parameters when being adjusted take immediate effect, but destination and source parameters do not. Using these parameter values while they are being adjusted could cause a malfunction in the operation of the drive if an intermediary value were taken during the adjustment. For the new value of one of these parameters to take effect a 'Drive Reset' must be carried out (see section 3.2.4 *Drive reset*).

Any changes made to parameters over the serial interface are not stored in the drives EEPROM until a manual store is initiated.

3.2.3 32 bit parameters

32 bit parameters cannot be displayed on the LED display. Source and destination parameters cannot be set to 32 bit parameters.

3.2.4 Drive reset

A drive reset is required for a number of reasons:

- To reset the drive from a tripped state
- To initiate loading of default parameters
- To implement a change in the value of certain parameters
- To initiate the saving of parameters in EEPROM

The later two of these can be done while the drive is running.

The drive can be reset in one of four ways:

1. The drive will be reset with a 0 to 1 transition of the enable input when the drive is tripped, such that a dedicated reset terminal is not required.
2. The drive will be reset when a 0 to 1 transition of the Drive Reset parameter Pr **10.33**. This parameter is provided for control by a programmable digital input such that a terminal can be used to reset the drive.
3. The Stop/Reset key. If the drive is not in keypad mode and the 'always stop' parameter is not set, then the key has a drive reset function only. In keypad mode or if the 'always stop' parameter is set, a drive reset can be done while the drive is running by holding the Run key while the Stop/Reset key is activated. When the drive is not running the Stop/Reset key will always reset the drive.
4. By the serial interface. This drive reset is triggered by a value of 100 being written to the User trip parameter Pr **10.38**.

3.2.5 Storing drive parameters

When the keypad is used to edit a parameter, the parameter is stored when the mode key is pressed after adjustment has been made.

When using the serial interface, parameters are stored by setting Pr **x.00** to a value of 1000 and performing a 'Drive reset'. Because a 'Drive reset' causes the values of certain parameters to be implemented, storing parameters has the effect of implementing all new values as the store takes place.

3.3 Key to parameter codes

In the following sections descriptions are given for the advanced parameter set. With each parameter the following information block is given.

5.11	Number of motor poles															
Coding	Bit	SP	FI	DE	Txt	VM	DP	ND	RA	NC	NV	PT	US	RW	BU	PS
					1								1	1	1	
Range	0 (Auto), 1 (2P), 2 (4P), 3 (6P), 4 (8P)															
Default	0 (Auto)															
Second motor parameter	Pr 21.11															
Update rate	Background															

The top row gives the menu:parameter number and the parameter name. The other rows give the following information.

3.3.1 Coding

The coding defines the attributes of the parameter as follows.

Coding	Attribute
Bit	1 bit parameter
SP	Spare: not used
FI	Filtered: some parameters which can have rapidly changing values are filtered when displayed on the drive keypad for easy viewing.
DE	Destination: indicates that this parameter can be a destination parameter.
Txt	Text: the parameter uses text strings instead of numbers.
VM	Variable maximum: the maximum of this parameter can vary.
DP	Decimal place: indicates the number of decimal places used by this parameter.
ND	No default: when defaults are loaded (except when the drive is manufactured or on EEPROM failure) this parameter is not modified.
RA	Rating dependant: this parameter is likely to have different values and ranges with drives of different voltage and current ratings. These parameters are not transferred by the SmartStick when the rating of the destination drive is different from the source drive.
NC	Not cloned: not transferred to or from the SmartStick during parameter cloning.
NV	Not visible: not visible on the keypad.
PT	Protected: cannot be used as a destination.
US	User save: saved in drive EEPROM when the user initiates a parameter save.
RW	Read/write: can be written by the user.
BU	Bit default one/unsigned: Bit parameters with this flag set to one have a default of one (all other bit parameters have a default of zero. Non-bit parameters are unipolar if this flag is one.
PS	Power-down save: automatically saved in drive EEPROM at power-down.

3.3.2 Term definitions

Range

This gives the range of the parameter and the values it can be adjusted to.

Default

The default values given are the standard drive defaults.

Second motor parameter

Some parameters have an equivalent second motor map value that can be used as an alternative when a second motor is selected with Pr **11.45**. Menu 21 contains all the second motor map parameters.

Update rate

Defines the rate at which the parameter data is written by the drive or read and acted upon by the drive. Where background update rate is specified, the update time depends on the drive processor load. Generally the update time is between 10ms and 100ms, however, the update time is significantly extended when loading defaults, transferring data to/from a SmartStick, or transferring blocks of parameters to/from the drive via the drive serial communications port.

3.4 Sources and destinations

3.4.1 Sources

Some functions have source parameters, i.e. drive outputs, PID controller etc. The source parameter range is Pr **0.00** to Pr **21.51**.

1. If the source parameter does not exist the input is taken as zero.
2. The input is given by (source value x 100%) / source parameter maximum.

3.4.2 Destinations

Some functions have destination parameters, i.e. drive inputs, etc. The destination parameter range is Pr **0.00** to Pr **21.51**.

1. If the destination parameter does not exist then the output value has no effect.
2. If the destination parameter is protected then the output value has no effect.
3. If the function output is a bit value (i.e. a digital input) the destination value is either 0 or 1 depending on the state of the function output. If the function output is not a bit value (i.e. analog input) the destination value is given by (function output x destination parameter maximum) / 100% rounded down. Pr **1.36** and Pr **1.37** are a special case. The scaling shown in the description of Pr **1.10** is used when any non-bit type quantity is routed to these parameters.
4. If more than one destination selector is routed to the same destination, the value of the destination parameter is undefined. The drive checks for this condition where the destinations are defined in any menu except menu 15. If a conflict occurs a dEst trip occurs that cannot be reset until the conflict is resolved.

3.4.3 Sources and destinations

1. Bit and non-bit parameters may be connected to each other as sources or destinations. The maximum for bit parameters is taken as one.
2. All new source and destination routing only changes to new set-up locations when the drive is reset.
3. When a destination is changed, the old destination is written to zero, unless the destination change is the result of loading defaults or transferring parameters from a SmartStick. When defaults are loaded the old destination is set to its default value.
4. Cannot select any of the 32 bit parameters.

3.5 Sample/update times

The samples/update times shown in the control terminal specification within the *Commander SK Product Data Guide* are the default sample/update times for the default terminal set-up. The sample/update time depends on the destination/source parameter of the digital or analog inputs/outputs. These sample/update times are the sample or update times for the control microprocessor. The actual sample/update time maybe slightly longer due to the design of the Commander SK.

3.5.1 Task routine times

At the beginning of each menu, there is a single line parameter description and this contains the update rate for each parameter. This time signifies the task routine time in the software that the parameter is updated on. For a background task, the time depends on processor loading i.e. what functions the drive is carrying out and what advanced menus are being used.

Update rate	Microprocessor update time	Comments
2ms	2ms	Updated every 2ms
5ms	5ms	Updated every 5ms
21ms	21ms	Updated every 21ms
128ms	128ms	Updated every 128ms
Reset	N/A	Destination/source parameter changed on a Reset
B	Background	Updated as a background task. Update rate depends on processor loading.
BR	Background read	
BW	Background write	

From practical tests carried out:

Condition	Minimum	Maximum	Average
Time for drive to respond to a run command	4.1ms	5.62ms	5.02ms
Time for the drive to respond to a stop command	2.82ms	3.94ms	3.31ms
Time for the drive to respond to a step change in analog input voltage			7.93ms

4 Keypad and display

The keypad and display are used for the following:

- Displaying the operating status of the drive
- Displaying a fault or trip code
- Reading and changing parameter values
- Stopping, starting and resetting the drive

Figure 4-1 Keypad and display

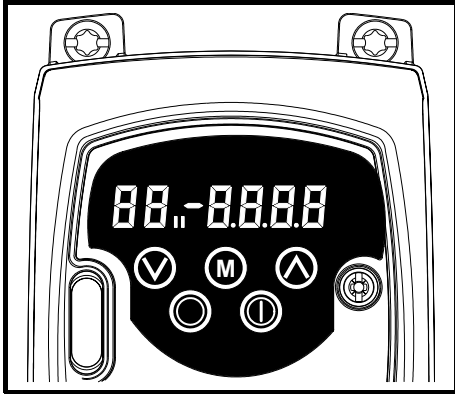

4.1 Programming keys

The **M** **MODE** key is used to change the mode of operation of the drive.

The **A** **UP** and **V** **DOWN** keys are used to select parameters and edit their values. In keypad mode, they are used to increase and decrease the speed of the motor.

4.2 Control keys

The **I** **START** key is used to start the drive in keypad mode.

The **O** **STOP/RESET** key is used to stop and reset the drive in keypad mode. It can also be used to reset the drive in terminal mode.

4.3 Selecting and changing parameters

NOTE

This procedure is written from the first power up of the drive and assumes no terminals have been connected, no parameters have been changed and no security has been set.

Figure 4-2

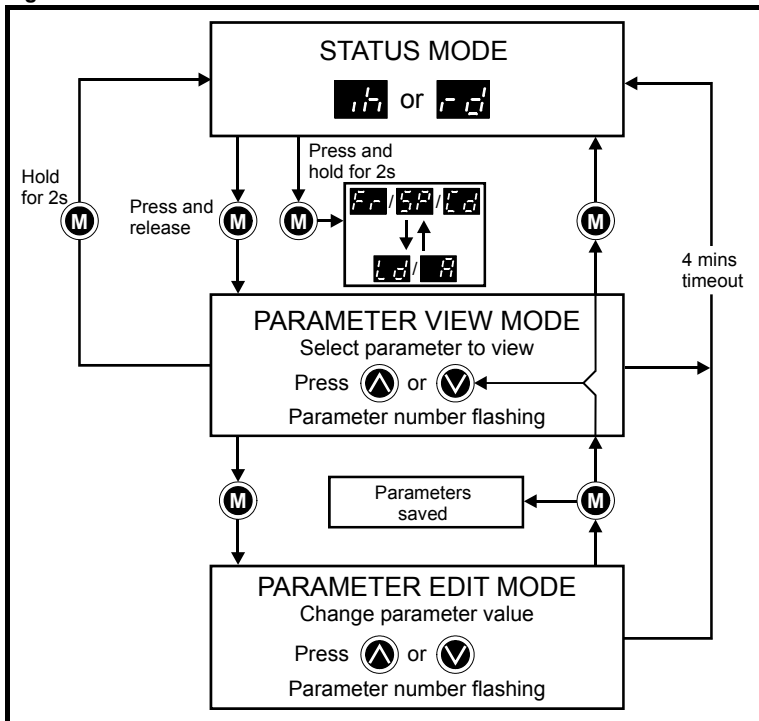

When in Status mode, pressing and holding the **M** **MODE** key for 2 seconds will change the display from displaying a speed indication to displaying

load indication and vice versa.

Pressing and releasing the **MODE** key will change the display from status mode to parameter view mode. In parameter view mode, the left hand display flashes the parameter number and the right hand display shows the value of that parameter.

Pressing and releasing the **MODE** key again will change the display from parameter view mode to parameter edit mode. In parameter edit mode, the right hand display flashes the value in the parameter being shown in the left hand display.

Pressing the **MODE** key in parameter edit mode will return the drive to the parameter view mode. If the **MODE** key is pressed again then the drive will return to status mode, but if either of the **UP** or **DOWN** keys are pressed to change the parameter being viewed before the **MODE** key is pressed, pressing the **MODE** key will change the display to the parameter edit mode again. This allows the user to very easily change between parameter view and edit modes whilst commissioning the drive.

Status Modes

Left hand display	Status	Explanation
	Drive ready	The drive is enabled and ready for a start command. The output bridge is inactive.
	Drive inhibited	The drive is inhibited because there is no enable command, or a coast to stop is in progress or the drive is inhibited during a trip reset.
	Drive has tripped	The drive has tripped. The trip code will be displayed in the right hand display.
	DC injection braking	DC injection braking current is being applied to the motor.

Speed Indications

Display Mnemonic	Explanation
	Drive output frequency in Hz
	Motor speed in rpm
	Machine speed in customer define units

Load indications

Display Mnemonic	Explanation
	Load current as a % of motor rated load current
	Drive output current per phase in A

The operation of the drives keypad and display is explained in the *Commander SK Getting Started Guide*.

When in parameter edit mode, the **UP** and **DOWN** keys are used to change parameter values. This will increase or decrease the parameter value by the minimum unit value on display.

To allow values to be changed more quickly, it is possible to press the **MODE** and **UP** or the **MODE** and **DOWN** keys together to allow either 1000's of units, 100's of units, 10's of units or units to be adjusted.

Example:

It is required that a deceleration ramp of 2500 seconds is required.

Select Pr **04** using the normal procedure.

- Press the **MODE** key to enter parameter edit mode
- Press the **MODE** and **UP** keys together
- Press the **UP** key to adjust the 100's of units
- Press the **MODE** and **UP** keys together again
- Press the **DOWN** key once to adjust the 10's of units
- Press the **MODE** key to go back to parameter view mode
- Press the **MODE** key again to go back to status mode

5 CT Modbus RTU

6 User programming (PLC Ladder logic programming)

User programming and SYPTLite

The Commander SK has the ability to store and execute a 4kb PLC ladder logic program.

NOTE

To enable the Commander SK to store and execute a SYPTLite program, a LogicStick must be fitted to the drive.

The ladder logic program is written using SYPTLite, a Windows based ladder diagram editor allowing the development of programs for execution in the Commander SK.

SYPTLite is designed to be easy to use and to make program development as simple as possible. SYPTLite programs are developed using ladder logic, a graphical language widely used to program PLCs (IEC 61131-3). SYPTLite allows the user to 'draw' a ladder diagram representing a program. SYPTLite provides a complete environment for the development of ladder diagrams. Ladder diagrams can be created, compiled into user programs and downloaded into the Commander SK for execution via the RJ45 serial communications port on the front of the drive. The run-time operation of the compiled ladder diagram on the target can also be monitored using SYPTLite and facilities are provided to interact with the program on the target by setting new values for target parameters.

SYPTLite is available on the CD which is provided with the drive. The LogicStick can be purchased from your local Control Techniques Drive Centre or Distributor.

Benefits

The combination of the User Programming and SYPTLite mean that Commander SK can replace nano and some micro PLCs in many applications. A Commander SK ladder logic program can contain up to 50 ladder logic rungs, up to 7 function blocks and 10 contacts per rung. The ladder logic program will be stored on the LogicStick.

In addition to the basic ladder symbols, SYPTLite contains:

- Arithmetic blocks
- Comparison blocks
- Timers
- Counters
- Multiplexers
- Latches
- Bit manipulation

Typical applications of the ladder logic program include:

- Ancillary pumps
- Fans and control valves
- Interlocking logic
- Sequences routines
- Custom control words

Limitations

The ladder logic program has the following limitations:

- The maximum program size is 3kbytes including the header and optional source code
- The user cannot create user variables. If they are needed, the user must use free registers in menus 18 and 20. The ladder logic program can manipulate any drive parameter except parameters in menu 0.
- The program is only accessible via the drive's RJ45 serial communications port.
- There are no real-time tasks i.e. the scheduling rate of the program cannot be guaranteed. The User Programming should not be used for time critical applications.

NOTE

The LogicStick is rated for 1,000,000 downloads. The LogicStick can be transferred from one drive to another or a fresh copy of a ladder logic program can be made on a different LogicStick by downloading the program from SYPTLite.

User program performance

Programs run at a low priority. The Commander SK provides a single background task in which to run the ladder diagram. The drive is prioritised to perform its major functions first e.g. motor control, and will use any remaining processing time to execute the ladder diagram. As the drive's processor becomes more heavily loaded running its major functions, less time is spent executing the program. SYPTLite displays the average execution time calculated over the last 10 scans of the user program.

Getting started and system requirements

SYPTLite can be found on the CD which is supplied with the drive.

- Commander SK LogicStick
- Windows 98/98SE/ME/NT4/2000/XP required
- Internet explorer V5.0 or later must be installed
- Minimum of 800x600 screen resolution with 256 colours
- 96MB RAM
- Pentium II 266MHz or better recommended
- Adobe Acrobat 5.10 or later (for parameter help)
- RS232 to RS485, RJ45 communications lead to connect the PC to the Commander SK

NOTE

The user must have administrator rights under Windows NT/2000/XP to install the software.

To install SYPTLite, insert the CD and the auto-run facility should start the front end screen, from which SYPTLite can be selected.

See the SYPTLite help file for more information regarding using SYPTLite, creating ladder diagrams and the function blocks available.

For the associated User Program parameters, see parameter Pr 11.47, Pr 11.48 and Pr 11.50 in the *Commander SK Advanced User Guide*.

User program trips

Trip	Diagnosis
t090	User program attempted divide by zero
t091	User program attempted access to non-existent parameter
t092	User program attempted to write to a read only parameter
t094	User program attempted to write a value to parameter which is out of range
t095	User program virtual memory stack overflow
t097	User program LogicStick removed
t096	User program invalid operating system call
t098	User program invalid instruction
t099	User program invalid function block argument

7 CT Soft

8 Menu 0

Table 8-1 Menu 0 parameters: single line descriptions

Par	Description	Default		Corresponding extended menu parameter	Setting
		Eur	USA		
01	Minimum set speed (Hz)	0.0		Pr 1.07	
02	Maximum set speed (Hz)	50.0	60.0	Pr 1.06	
03	Acceleration rate (s/100Hz)	5.0		Pr 2.11	
04	Deceleration rate (s/100Hz)	10.0		Pr 2.21	
05	Drive configuration	AI.AV		Pr 11.27	
06	Motor rated current (A)	Drive rating		Pr 5.07	
07	Motor rated speed (rpm)	1500	1800	Pr 5.08	
08	Motor rated voltage (V)	230/400	230/460	Pr 5.09	
09	Motor power factor (cos φ)	0.85		Pr 5.10	
10	Parameter access	L1		Pr 11.44	
11	Start/Stop logic select	0	4	Pr 6.04	
12	Brake enable	diS		Pr 12.41	
15	Jog reference (Hz)	1.5		Pr 1.05	
16	Analog 1 input mode (mA)	4-20		Pr 7.06	
17	Enable negative preset speeds	OFF (0)		Pr 1.10	
18	Preset speed 1 (Hz)	0		Pr 1.21	
19	Preset speed 2 (Hz)	0		Pr 1.22	
20	Preset speed 3 (Hz)	0		Pr 1.23	
21	Preset speed 4 (Hz)	0		Pr 1.24	
22	Load display units	Ld		Pr 4.21	
23	Speed display units	Fr		Pr 5.34	
24	Customer defined scaling	1.000		Pr 11.21	
25	Security set up	0		Pr 11.30	
27	Power up keypad reference	0		Pr 1.51	
28	Parameter cloning	no		Pr 11.42	
29	Load defaults	no		Pr 11.43	
30	Ramp mode	1		Pr 2.04	
31	Stopping mode	0		Pr 6.01	
32	Variable torque select	0		Pr 5.13	
33	Catch a spinning motor select	OFF (0)		Pr 6.09	
34	Terminal B7 function select	dig		Pr 8.35	
35	Digital output mode (terminal B3)	n=0		Pr 8.41	
36	Analog output mode (terminal B1)	Fr		Pr 7.33	
37	Maximum switching frequency (kHz)	3		Pr 5.18	
38	Autotune	0		Pr 5.12	
39	Motor rated frequency (Hz)	50.0	60.0	Pr 5.06	
40	Number of poles	Auto		Pr 5.11	
41	Voltage mode selector	Ur l		Pr 5.14	
42	Low frequency voltage boost (%)	3.0		Pr 5.15	
43	Serial comms baud rate	19.2		Pr 11.25	
44	Serial address	1		Pr 11.23	
45	Software version			Pr 11.29	
46	Brake release current threshold (%)	50		Pr 12.42	
47	Brake applied current threshold (%)	10		Pr 12.43	
48	Brake release frequency (Hz)	1.0		Pr 12.44	
49	Brake applied frequency (Hz)	2.0		Pr 12.45	
50	Pre-brake release delay (s)	1.0		Pr 12.46	
51	Post brake release delay (s)	1.0		Pr 12.47	
52	Fieldbus node address	0		Pr 15.03	
53	Fieldbus baud rate	0		Pr 15.04	
54	Fieldbus diagnostics	0		Pr 15.06	
55	Last trip			Pr 10.20	
56	Trip before Pr 55			Pr 10.21	

Par	Description	Default		Corresponding extended menu parameter	Setting
		Eur	USA		
57	Trip before Pr 56			Pr 10.22	
58	Trip before Pr 57			Pr 10.23	
59	Drive user program enable	0		Pr 11.47	
60	Drive use program status			Pr 11.48	
61	Configurable parameter 1			Pr 11.01	
62	Configurable parameter 2			Pr 11.02	
63	Configurable parameter 3			Pr 11.03	
64	Configurable parameter 4			Pr 11.04	
65	Configurable parameter 5			Pr 11.05	
66	Configurable parameter 6			Pr 11.06	
67	Configurable parameter 7			Pr 11.07	
68	Configurable parameter 8			Pr 11.08	
69	Configurable parameter 9			Pr 11.09	
70	Configurable parameter 10			Pr 11.10	
71	Pr 61 set up parameter				
72	Pr 62 set up parameter				
73	Pr 63 set up parameter				
74	Pr 64 set up parameter				
75	Pr 65 set up parameter				
76	Pr 66 set up parameter				
77	Pr 67 set up parameter				
78	Pr 68 set up parameter				
79	Pr 69 set up parameter				
80	Pr 70 set up parameter				
81	Reference selected	Read only diagnostic parameters		Pr 1.01	
82	Pre-ramp reference			Pr 1.03	
83	Post-ramp reference			Pr 2.01	
84	DC Bus voltage			Pr 5.05	
85	Motor frequency			Pr 5.01	
86	Motor voltage			Pr 5.02	
87	Motor speed			Pr 5.04	
88	Motor current			Pr 4.01	
89	Motor active current			Pr 4.02	
90	Digital I/O read word			Pr 8.25	
91	Reference on indicator			Pr 1.11	
92	Reverse selected indicator			Pr 1.12	
93	Jog selected indicator			Pr 1.13	
94	Analog input 1			Pr 7.01	
95	Analog input 2			Pr 7.02	

Figure 8-1 Menu 0 logic diagram

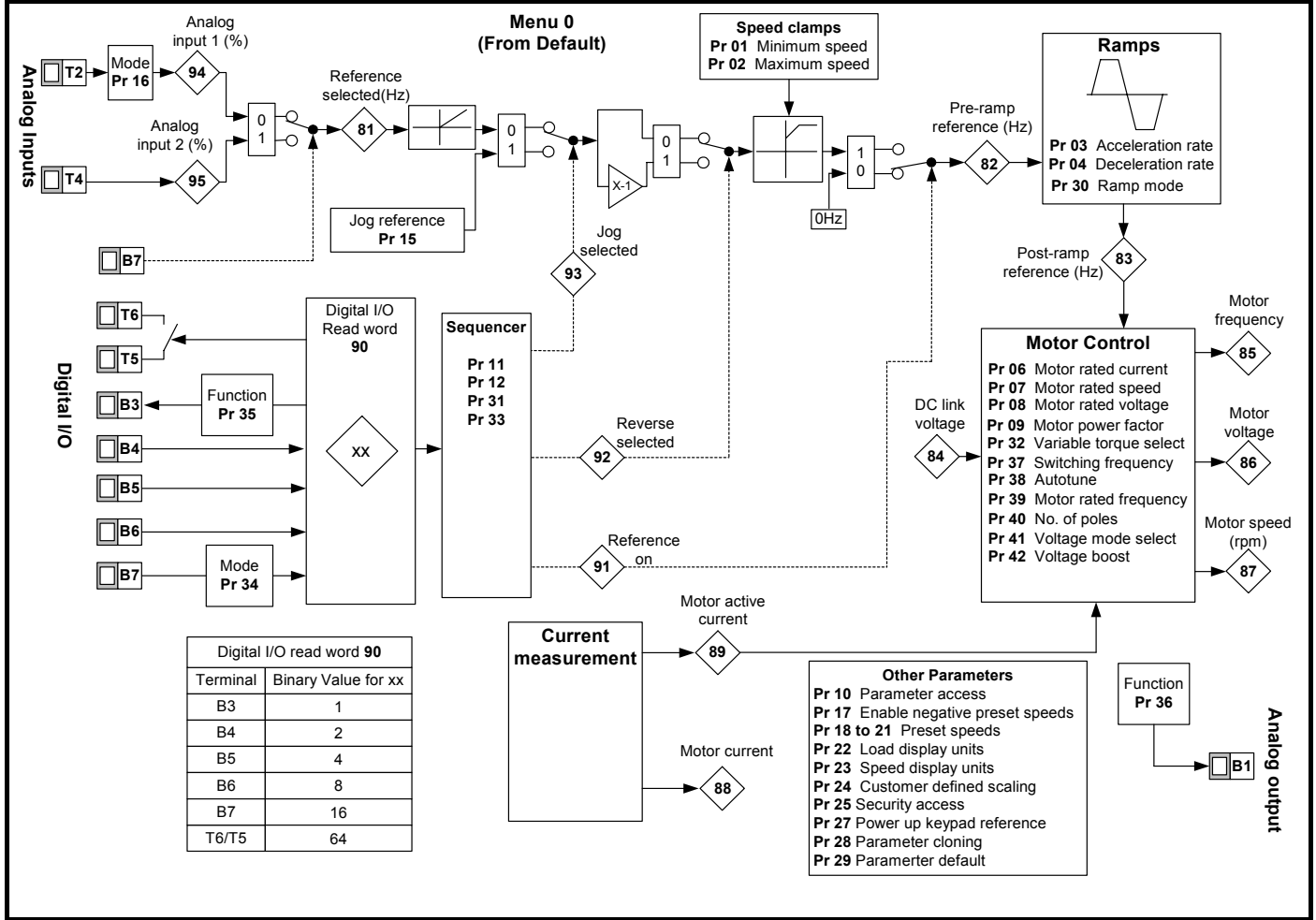

Digital I/O read word 90	
Terminal	Binary Value for xx
B3	1
B4	2
B5	4
B6	8
B7	16
T6/T5	64

9 Advanced parameter descriptions

9.1 Overview

Table 9-1 Menu descriptions

Menu no.	Description
1	Frequency / speed reference
2	Ramps
3	Slave frequency, speed feedback and speed control
4	Current control
5	Motor control
6	Sequencer and clock
7	Analog I/O
8	Digital I/O
9	Programmable logic, motorised pot and binary sum
10	Status and trips
11	General drive set-up
12	Threshold detectors and variable selectors
14	User PID controller
15*	I/O option parameters
18	Application menu 1
20	Application menu 2
21	Second motor parameters

*Only appears when an I/O option module is fitted to the Commander SK.

Table 9-2 gives a full key of the coding which appears in the following parameter tables.

Table 9-2 Key to parameter coding

Coding	Attribute
Bit	1 bit parameter
SP	Spare: not used
FI	Filtered: some parameters which can have rapidly changing values are filtered when displayed on the drive keypad for easy viewing.
DE	Destination: indicates that this parameter can be a destination parameter.
Txt	Text: the parameter uses text strings instead of numbers.
VM	Variable maximum: the maximum of this parameter can vary.
DP	Decimal place: indicates the number of decimal places used by this parameter.
ND	No default: when defaults are loaded (except when the drive is manufactured or on EEPROM failure) this parameter is not modified.
RA	Rating dependant: this parameter is likely to have different values and ranges with drives of different voltage and current ratings. These parameters are not transferred by SmartStick when the rating of the destination drive is different from the source drive.
NC	Not cloned: not transferred to or from SmartStick during cloning.
NV	Not visible: not visible on the keypad.
PT	Protected: cannot be used as a destination.
US	User save: saved in drive EEPROM when the user initiates a parameter save.
RW	Read/write: can be written by the user.
BU	Bit default one/unsigned: Bit parameters with this flag set to one have a default of one (all other bit parameters have a default of zero. Non-bit parameters are unipolar if this flag is one.
PS	Power-down save: automatically saved in drive EEPROM at power-down.

9.2 Menu 1: Speed reference selection, limits and filters

Table 9-3 Menu 1 parameters: single line descriptions

Parameter		Range	Default	Setting	Update Rate
1.01	Frequency reference selected	± 1500.0 Hz*			5 ms
1.02	Pre-skip filter reference	± 1500.0 Hz			5 ms
1.03	Pre-ramp reference	± 1500.0 Hz			5 ms
1.04	Reference offset	± 1500.0 Hz	0.0		5 ms
1.05	Jog reference {15}	0.0 to 400.0 Hz	1.5		5 ms
1.06	Maximum set speed {02}	0.0 to 1500.0 Hz	50(EUR) 60(USA)		B
1.07	Minimum set speed {01}	0.0 to Pr 1.06	0.0		B
1.08	Not used				
1.09	Reference offset select	0 or 1	0		5 ms
1.10	Allow negative references {17}	0 or 1	0		B
1.11	Reference enabled indicator	0 or 1			2 ms
1.12	Reverse selected indicator	0 or 1			2 ms
1.13	Jog selected indicator	0 or 1			2 ms
1.14	Reference selector	0 to 5	0		5 ms
1.15	Preset selector	0 to 8	0		5 ms
1.16	Not used				
1.17	Keypad control mode reference	± 1500.0 Hz	0.0		B
1.18	Precision reference coarse	± 1500.0 Hz	0.0		5 ms
1.19	Precision reference fine	0.000 to 0.099 Hz	0.000		5 ms
1.20	Precision reference update disable	0 or 1	0		5 ms
1.21	Preset speed 1 {18}	± 1500.0 Hz	0.0		5 ms
1.22	Preset speed 2 {19}	± 1500.0 Hz	0.0		5 ms
1.23	Preset speed 3 {20}	± 1500.0 Hz	0.0		5 ms
1.24	Preset speed 4 {21}	± 1500.0 Hz	0.0		5 ms
1.25	Preset speed 5	± 1500.0 Hz	0.0		5 ms
1.26	Preset speed 6	± 1500.0 Hz	0.0		5 ms
1.27	Preset speed 7	± 1500.0 Hz	0.0		5 ms
1.28	Preset speed 8	± 1500.0 Hz	0.0		5 ms
1.29	Skip reference 1	0.0 to 1500.0 Hz	0.0		B
1.30	Skip reference band 1	0.0 to 25 Hz	0.5		B
1.31	Skip reference 2	0.0 to 1500.0 Hz	0.0		B
1.32	Skip reference band 2	0.0 to 25 Hz	0.5		B
1.33	Skip reference 3	0.0 to 1500.0 Hz	0.0		B
1.34	Skip reference band 3	0.0 to 25 Hz	0.5		B
1.35	Reference in rejection zone	0 or 1			5 ms
1.36	Analog reference 1	± 1500.0 Hz*			5 ms
1.37	Analog reference 2	± 1500.0 Hz*			5 ms
1.38	Percentage trim	±100.0%	0.0		5 ms
1.39	Not used				
1.40	Not used				
1.41	Analog reference 2 select	0 or 1	0		5 ms
1.42	Preset reference select	0 or 1	0		5 ms
1.43	Keypad reference select	0 or 1	0		5 ms
1.44	Precision reference select	0 or 1	0		5 ms
1.45	Preset select bit 0	0 or 1	0		5 ms
1.46	Preset select bit 1	0 or 1	0		5 ms
1.47	Preset select bit 2	0 or 1	0		5 ms
1.48	Not used				
1.49	Reference selected indicator	1 to 5			5 ms
1.50	Preset Reference selected indicator	1 to 8			5 ms
1.51	Power up keypad control reference {27}	0 to 2	0		N/A

* The maximum value is Pr 1.06 or Pr 21.01

Figure 9-1 Menu 1A logic diagram

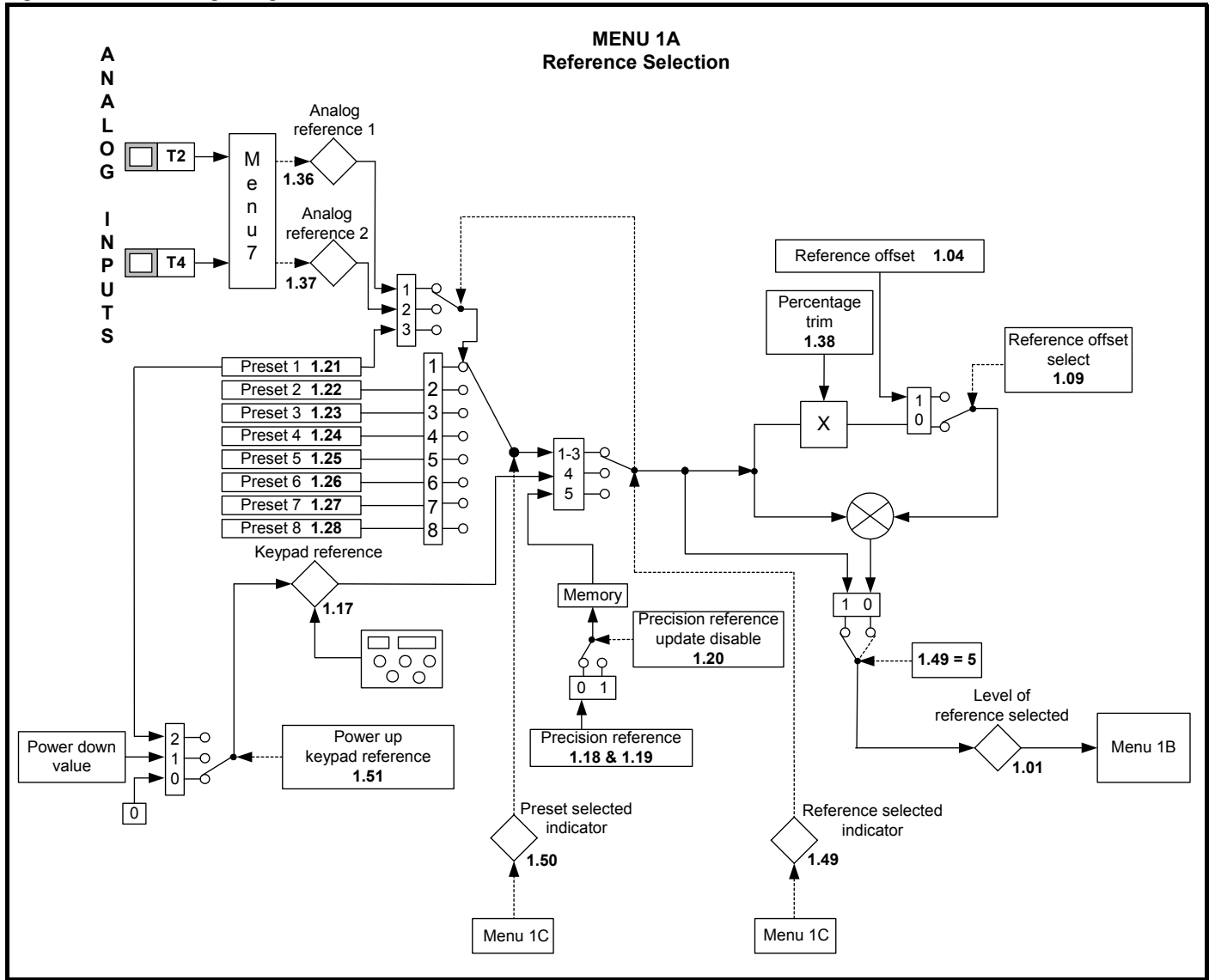

Figure 9-2 Menu 1B logic diagram

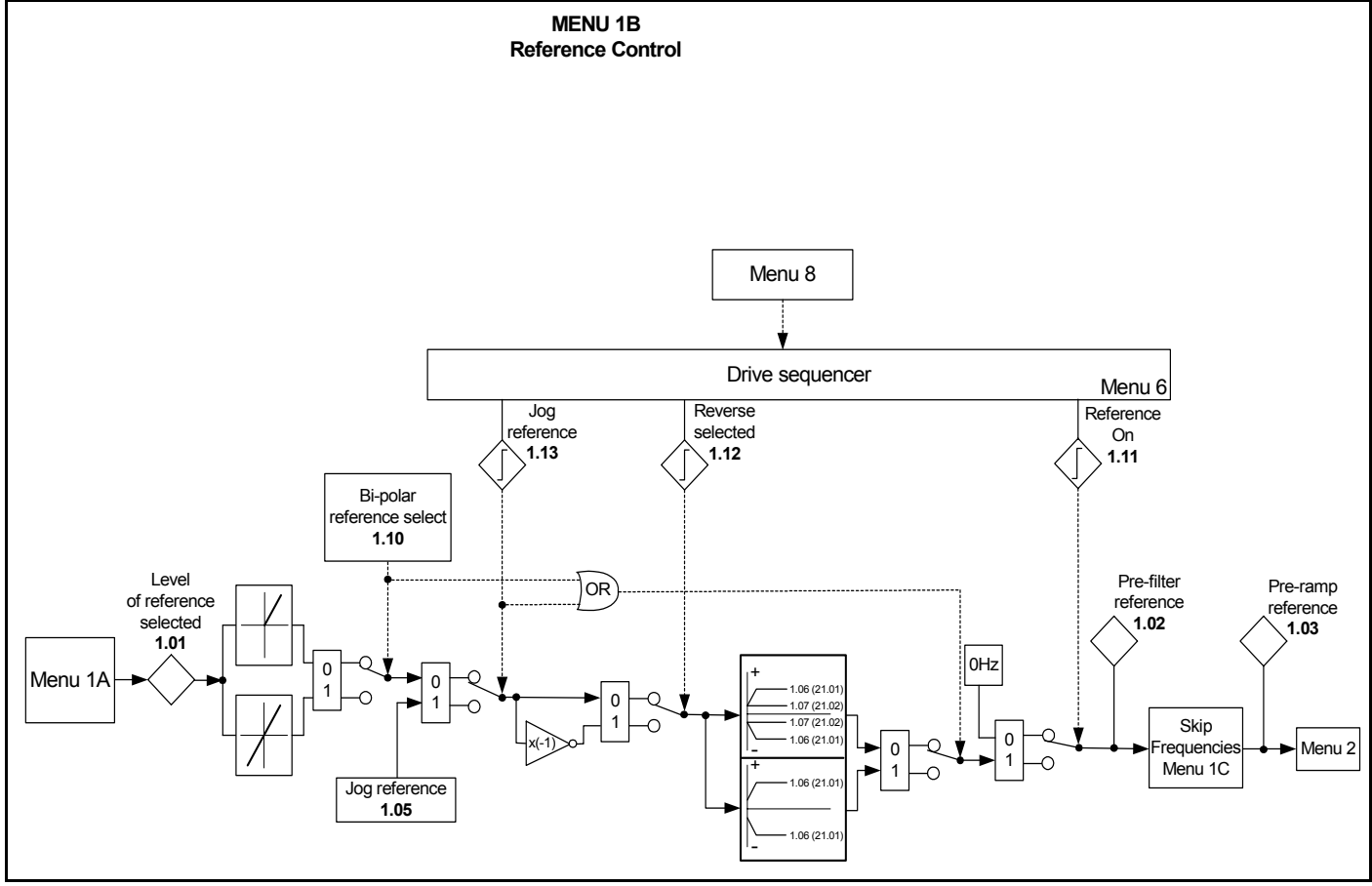

Figure 9-3 Menu 1C logic diagram

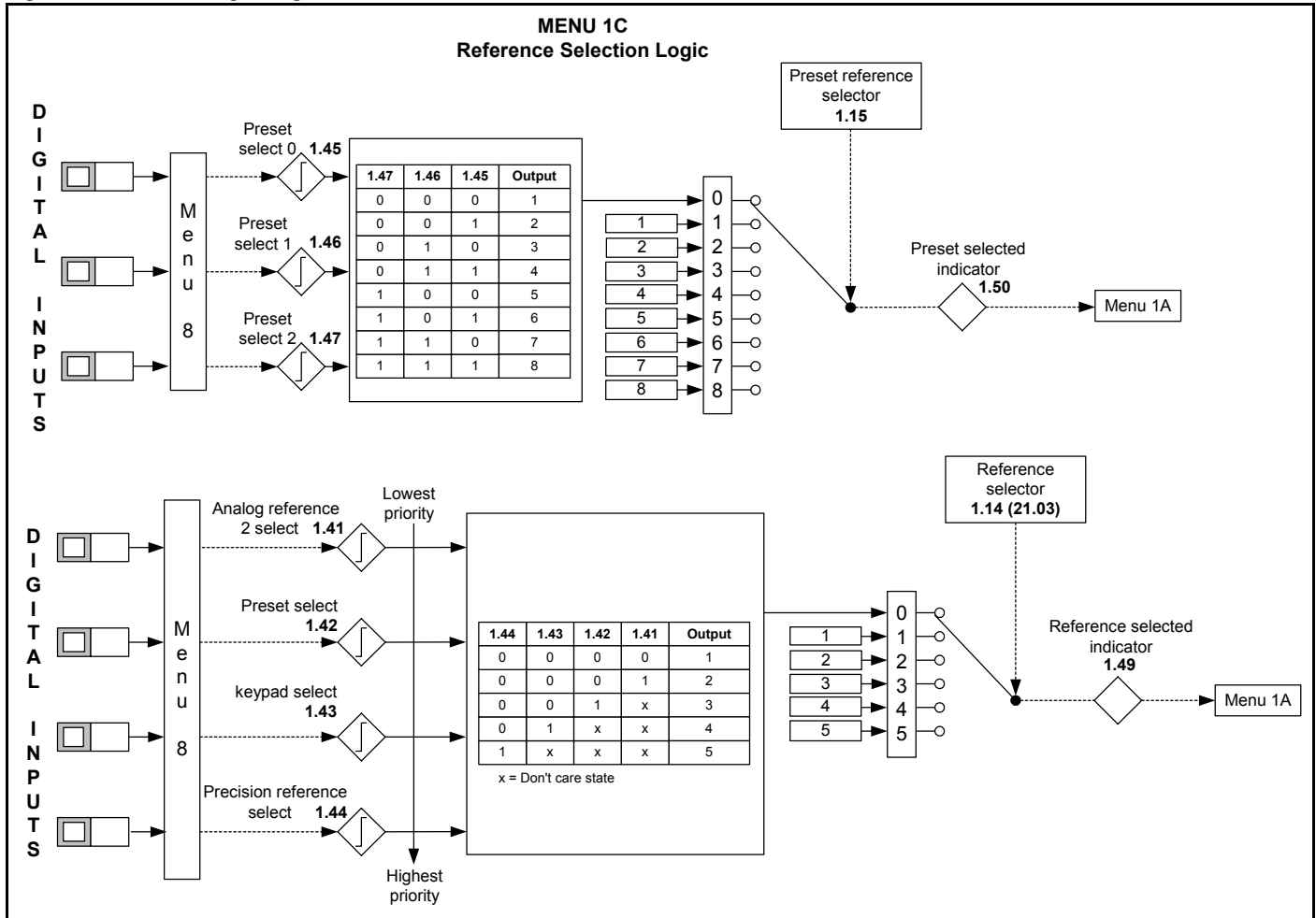
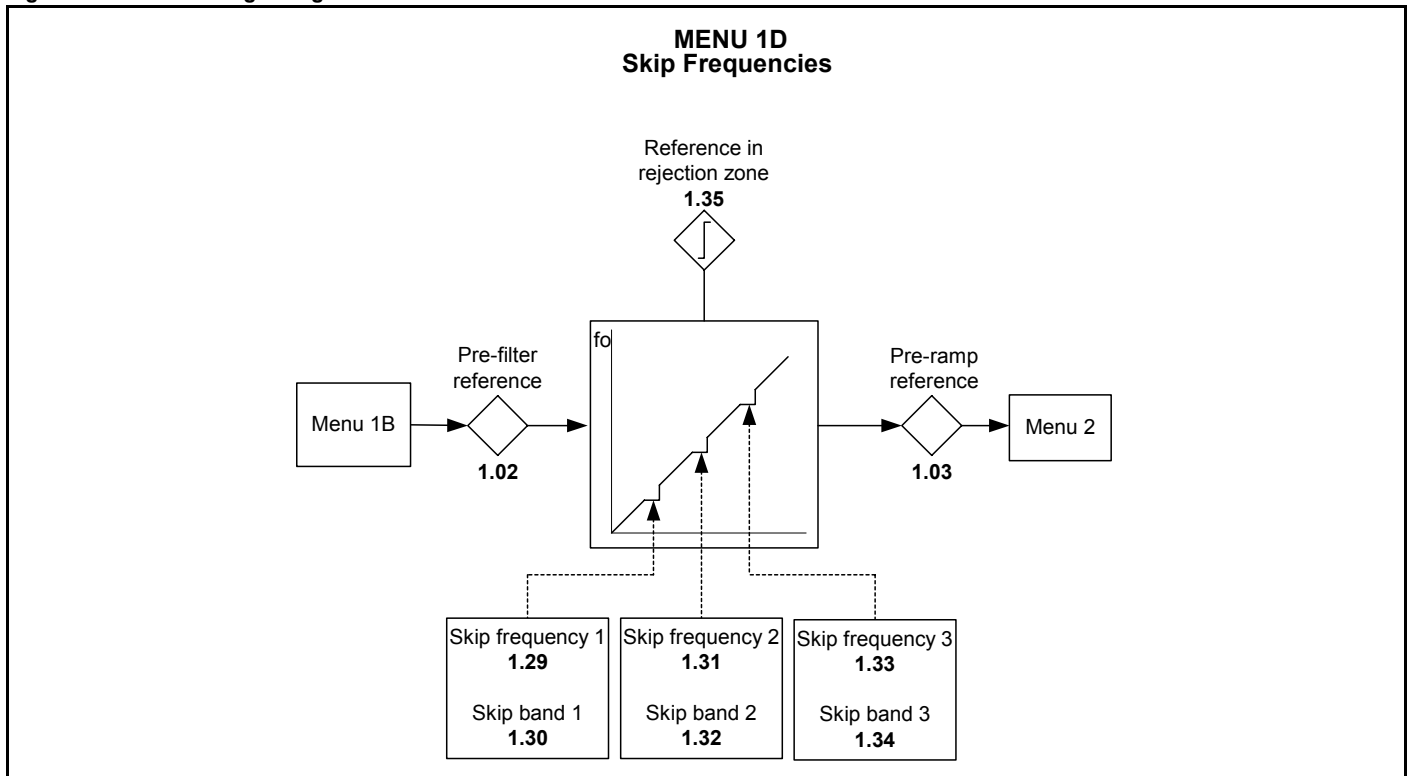

Figure 9-4 Menu 1D logic diagram



1.01	Frequency reference selected															
Coding	Bit	SP	FI	DE	Txt	VM	DP	ND	RA	NC	NV	PT	US	RW	BU	PS
						1	1	1		1		1				
Range	±1500.0 Hz															
Update rate	5ms															

Indication of the reference being used by the drive for system setup and fault finding.

1.02	Pre-skip filter reference															
Coding	Bit	SP	FI	DE	Txt	VM	DP	ND	RA	NC	NV	PT	US	RW	BU	PS
						1	1	1		1		1				
Range	±1500.0 Hz															
Update rate	5ms															

1.03	Pre-ramp reference															
Coding	Bit	SP	FI	DE	Txt	VM	DP	ND	RA	NC	NV	PT	US	RW	BU	PS
						1	1	1		1		1				
Range	±1500.0 Hz															
Update rate	5ms															

Indication of the reference being used by the drive for system setup and fault finding.

1.04	Reference offset															
Coding	Bit	SP	FI	DE	Txt	VM	DP	ND	RA	NC	NV	PT	US	RW	BU	PS
						1	1						1	1		
Range	±1500.0 Hz															
Default	0.0															
Update rate	5ms															

See Pr 1.09 on page 25.

1.05	Jog reference															
Coding	Bit	SP	FI	DE	Txt	VM	DP	ND	RA	NC	NV	PT	US	RW	BU	PS
							1						1	1	1	
Range	0.0 to 400.0 Hz															
Default	1.5															
Update rate	5ms															

Reference used for jogging. See section 9.7 *Menu 6: Drive sequencer and clock* for details on when the jog mode can be activated.

1.06	Maximum set speed															
Coding	Bit	SP	FI	DE	Txt	VM	DP	ND	RA	NC	NV	PT	US	RW	BU	PS
							1						1	1	1	
Range	0.0 to 1500.0 Hz															
Default	EUR: 50.0 USA: 60.0															
Second motor parameter	Pr 21.01															
Update rate	Background															

This parameter is a symmetrical limit on both directions of rotation.

Defines drive absolute maximum frequency reference. Slip compensation and current limit can increase the motor frequency further.

1.07	Minimum set speed															
Coding	Bit	SP	FI	DE	Txt	VM	DP	ND	RA	NC	NV	PT	US	RW	BU	PS
						1	1						1	1	1	
Range	0.0 to 1500.0 Hz															
Default	0.0															
Second motor parameter	Pr 21.02															
Update rate	Background															

Used in unipolar mode to define drive minimum set speed. This can be overridden if the maximum set speed clamp Pr 1.06 is adjusted to be less than Pr 1.07. Inactive during jogging.

1.08	Unused parameter														
-------------	-------------------------	--	--	--	--	--	--	--	--	--	--	--	--	--	--

1.09	Reference offset select															
Coding	Bit	SP	FI	DE	Txt	VM	DP	ND	RA	NC	NV	PT	US	RW	BU	PS
	1												1	1		
Default	0															
Update rate	5ms															

When this parameter is 0 the reference is given by:
 $Pr\ 1.01 = \text{selected reference} \times (100 + Pr\ 1.38) / 100$
 and when this parameter is 1 the reference is given by:
 $Pr\ 1.01 = \text{SELECTED REFERENCE} + Pr\ 1.04$

1.10	Allow negative references															
Coding	Bit	SP	FI	DE	Txt	VM	DP	ND	RA	NC	NV	PT	US	RW	BU	PS
	1												1	1		
Default	0															
Update rate	Background															

- 0: Allow negative references disabled
- 1: Allow negative references enabled

Needs to be set if the user requires to change the direction of rotation with a bipolar reference. If it is not set, all negative references are treated as zero. Possible bipolar references are:

- Preset speeds 1 to 8
- Keypad reference
- Precision reference
- Analog reference from I/O option module
- Reference from a comms option module

NOTE

Both standard analog inputs are unipolar and setting this bit does not allow bipolar analog references to be applied to the drive. However, the I/O option module will have a bipolar input for this purpose.

Analog input scaling

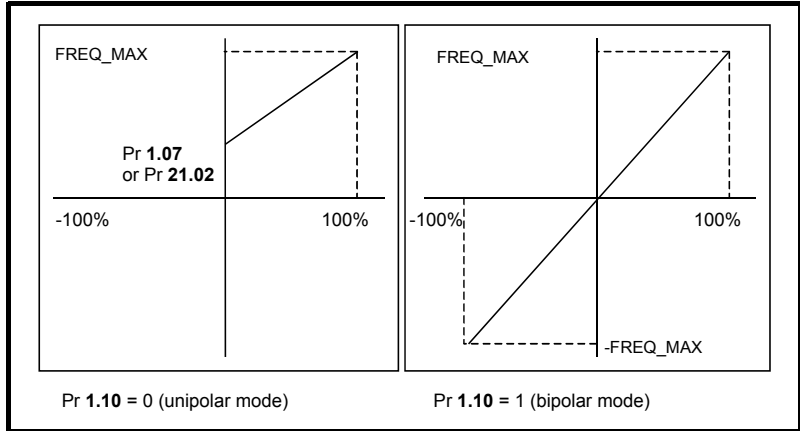

1.11	Reference enabled indicator															
1.12	Reverse selected indicator															
1.13	Jog selected indicator															
Coding	Bit	SP	FI	DE	Txt	VM	DP	ND	RA	NC	NV	PT	US	RW	BU	PS
	1							1		1		1				
Update rate	2ms															

These flags are controlled by the drive sequencer defined in Menu 6. They select the appropriate reference as commanded by the drive logic.

1.14	Reference selector															
Coding	Bit	SP	FI	DE	Txt	VM	DP	ND	RA	NC	NV	PT	US	RW	BU	PS
					1								1	1	1	
Range	0 to 5															
Default	0 (AI.AV)															
Second motor parameter	Pr 21.03															
Update rate	5ms															

This parameter is used to select a speed reference for motor 1 as follows:

- 0: AI.AV Analog reference 1 or 2 selected by terminal input
- 1: AV.Pr Analog reference 1 (voltage) or Presets selected by terminal input
- 2: AI.Pr Analog reference 1 (current) or Presets selected by terminal input
- 3: Pr Preset reference selected by terminal
- 4: PAd Keypad reference selected
- 5: Prc Precision reference selected

Pr 1.14	Terminal T4 Destination	Terminal B7 Destination	Pr 1.49
0 (AI.AV)	Pr 1.37	Pr 1.41	Selected by terminal input
1 (AV.Pr)	Pr 1.45	Pr 1.46	1
2 (AI.Pr)	Pr 1.45	Pr 1.46	2
3 (Pr)	Pr 1.45	Pr 1.46	3
4 (PAd)			4
5 (Prc)			5

When this parameter is set to 0 the reference selected depends on the state of bit parameters Pr 1.41 to Pr 1.44. These bits are for control by digital inputs such that references can be selected by external control. If any of the bits are set, the appropriate reference is selected (indicated by Pr 1.49). If more than one bit is set the highest numbered will have priority.

In modes 1 and 2 a preset speed will be selected instead of the voltage or current selection if the preset selected is any preset speed other than preset speed 1. This gives the user the flexibility to be able to select between voltage and 3 presets, or current and three presets, with only two digital inputs.

NOTE

When Pr 1.14 is set to 5 (Prc), Pr 1.04, Pr 1.09 and Pr 1.38 cannot be used.

Pr 1.41	Pr 1.42	Pr 1.43	Pr 1.44	Reference selected	Pr 1.49
0	0	0	0	Analog reference 1 (AI)	1
1	0	0	0	Analog reference 2 (AV)	2
X	1	0	0	Preset reference (Pr)	3
X	X	1	0	Keypad reference (PAd)	4
X	X	X	1	Precision reference (Prc)	5

Keypad reference

If Keypad reference is selected, the drive sequencer is controlled directly by the keypad keys and the keypad reference parameter (Pr 1.17) is selected. The sequencing bits, Pr 6.30 to Pr 6.34, have no effect and jog is disabled.

NOTE

There is no forward/ reverse button on the drives keypad. If a forward/ reverse is required in keypad mode, see Pr 11.27 for how to set this up.

Note: For existing users of Commander SE:

On Commander SE, Pr 1.14 (Pr 21.03) used to correspond to Pr 05.

On Commander SK, Pr 11.27 corresponds to Pr 05.

If Pr 05 or Pr 11.27 is used in a desired system set-up and then Pr 1.14 (Pr 21.03) is then used to change this set-up, although some of these set-ups for Pr 05 and Pr 1.14 (Pr 21.03) are the same, the displayed value showing the set-up of Pr 05 (AI.AV, AV.Pr etc.) will not change to the setting of Pr 1.14 (Pr 21.03).

1.15	Preset selector																																
Coding	<table border="1"> <tr> <td>Bit</td> <td>SP</td> <td>FI</td> <td>DE</td> <td>Txt</td> <td>VM</td> <td>DP</td> <td>ND</td> <td>RA</td> <td>NC</td> <td>NV</td> <td>PT</td> <td>US</td> <td>RW</td> <td>BU</td> <td>PS</td> </tr> <tr> <td></td> <td></td> <td></td> <td></td> <td></td> <td></td> <td></td> <td></td> <td></td> <td></td> <td></td> <td></td> <td>1</td> <td>1</td> <td>1</td> <td></td> </tr> </table>	Bit	SP	FI	DE	Txt	VM	DP	ND	RA	NC	NV	PT	US	RW	BU	PS													1	1	1	
Bit	SP	FI	DE	Txt	VM	DP	ND	RA	NC	NV	PT	US	RW	BU	PS																		
												1	1	1																			
Range	0 to 8																																
Default	0																																
Update rate	5ms																																

This parameter is used to select a preset speed reference as follows:

- 0 Preset selection by terminal input
- 1 Preset 1 selected if Pr 1.49 = 3, AN1 selected if Pr 1.49 = 1, AN2 selected if Pr 1.49 = 2
- 2 Preset 2 selected
- 3 Preset 3 selected
- 4 Preset 4 selected
- 5 Preset 5 selected
- 6 Preset 6 selected
- 7 Preset 7 selected
- 8 Preset 8 selected

When this parameter is set to 0 the preset selected depends on the state of bit parameters Pr 1.45, Pr 1.46 and Pr 1.47. These bits are for control by digital inputs such that presets can be selected by external control. The preset selected depends on the binary code generated by these bits as follows:

Pr 1.47	Pr 1.46	Pr 1.45	Preset selected Pr 1.50
0	0	0	1 (if Pr 1.49 = 3)
0	0	1	2
0	1	0	3
0	1	1	4
1	0	0	5
1	0	1	6
1	1	0	7
1	1	1	8

Pr 1.50 indicates the preset selected at all times.

If the reference selected by Pr 1.14 (or Pr 21.03) is 1 or 2 (current or voltage) a preset will be selected instead of the current or voltage selection if the preset selected is any other than 1. This give the user the flexibility to be able to select between voltage and 3 presets, or current and three presets, with only two digital inputs.

1.16	Unused parameter
-------------	-------------------------

1.17	Keypad reference																																
Coding	<table border="1"> <tr> <td>Bit</td> <td>SP</td> <td>FI</td> <td>DE</td> <td>Txt</td> <td>VM</td> <td>DP</td> <td>ND</td> <td>RA</td> <td>NC</td> <td>NV</td> <td>PT</td> <td>US</td> <td>RW</td> <td>BU</td> <td>PS</td> </tr> <tr> <td></td> <td></td> <td></td> <td></td> <td></td> <td>1</td> <td>1</td> <td></td> <td></td> <td>1</td> <td></td> <td>1</td> <td></td> <td></td> <td></td> <td>1</td> </tr> </table>	Bit	SP	FI	DE	Txt	VM	DP	ND	RA	NC	NV	PT	US	RW	BU	PS						1	1			1		1				1
Bit	SP	FI	DE	Txt	VM	DP	ND	RA	NC	NV	PT	US	RW	BU	PS																		
					1	1			1		1				1																		
Range	±1500.0Hz																																
Default	0.0																																
Update rate	Background																																

This parameter is the reference used when keypad reference is selected.

The range depends on the setting of Pr 1.10:

- Pr 1.10 Range
- 0:Pr 1.07 to 1500 Hz or Pr 21.02 to 1500 Hz
- 1:±1500 Hz

1.18	Precision reference coarse																																
Coding	<table border="1"> <tr> <td>Bit</td> <td>SP</td> <td>FI</td> <td>DE</td> <td>Txt</td> <td>VM</td> <td>DP</td> <td>ND</td> <td>RA</td> <td>NC</td> <td>NV</td> <td>PT</td> <td>US</td> <td>RW</td> <td>BU</td> <td>PS</td> </tr> <tr> <td></td> <td></td> <td></td> <td></td> <td></td> <td>1</td> <td>1</td> <td></td> <td></td> <td></td> <td></td> <td></td> <td>1</td> <td>1</td> <td></td> <td></td> </tr> </table>	Bit	SP	FI	DE	Txt	VM	DP	ND	RA	NC	NV	PT	US	RW	BU	PS						1	1						1	1		
Bit	SP	FI	DE	Txt	VM	DP	ND	RA	NC	NV	PT	US	RW	BU	PS																		
					1	1						1	1																				
Range	±1500.0Hz																																
Default	0.0																																
Update rate	5ms																																

1.19	Precision reference fine															
Coding	Bit	SP	FI	DE	Txt	VM	DP	ND	RA	NC	NV	PT	US	RW	BU	PS
							3						1	1	1	
Range	0.000 to 0.099Hz															
Default	0.000															
Update rate	5ms															

The drives normal frequency resolution is 0.1Hz.

Selecting these two parameters as a reference automatically selects high resolution control (unless a frequency limit is hit or slip compensation is enabled). The frequency in this case will have a resolution of 0.001Hz. Pr 1.18 defines the reference (either positive or negative) with a resolution of 0.1Hz. Pr 1.19 defines the fine part of the reference (always positive). The final reference is given by Pr 1.18 + Pr 1.19. Therefore Pr 1.19 increases positive references away from zero, and decreases negative references towards zero.

1.20	Precision reference update disable															
Coding	Bit	SP	FI	DE	Txt	VM	DP	ND	RA	NC	NV	PT	US	RW	BU	PS
	1									1				1		
Default	0															
Update rate	5ms															

- 0: Precision reference update disable off
- 1: Precision reference update disable on

When this parameter is set to 0, the pre-ramp reference (Pr 1.01) is updated with the precision reference parameters (Pr 1.18 and Pr 1.19). If the precision reference parameters are changed while this parameter is set to 0, the pre-ramp reference will be updated immediately.

When this parameter is set at 1, the precision reference update parameters (Pr 1.18 and Pr 1.19) are continually read and updated in internal memory but the pre-ramp reference (Pr 1.01) is not updated. Because the precision reference has to be set in two parameters, this parameter being set to a 1 prevents the reference from being updated while the parameters are being changed. This prevents the possibility of data skew.

1.21	Preset speed 1															
1.22	Preset speed 2															
1.23	Preset speed 3															
1.24	Preset speed 4															
1.25	Preset speed 5															
1.26	Preset speed 6															
1.27	Preset speed 7															
1.28	Preset speed 8															
Coding	Bit	SP	FI	DE	Txt	VM	DP	ND	RA	NC	NV	PT	US	RW	BU	PS
						1	1						1	1		
Range	±1500.0Hz															
Default	0.0															
Update rate	5ms															

Defines preset speeds 1 to 8

1.29	Skip reference 1															
1.31	Skip reference 2															
1.33	Skip reference 3															
Coding	Bit	SP	FI	DE	Txt	VM	DP	ND	RA	NC	NV	PT	US	RW	BU	PS
							1						1	1	1	
Range	0 to 1500.0Hz															
Default	0.0															
Update rate	Background															

See Pr 1.30, Pr 1.32 and Pr 1.34 description.

1.30	Skip reference band 1															
1.32	Skip reference band 2															
1.34	Skip reference band 3															
Coding	Bit	SP	FI	DE	Txt	VM	DP	ND	RA	NC	NV	PT	US	RW	BU	PS
						1							1	1	1	
Range	0.0 to 25.0Hz															
Default	0.5															
Update rate	Background															

Three skip references are available to prevent continuous operation at a speed that would cause mechanical resonance. When a skip reference parameter is set to 0 that filter is disabled. The skip reference band parameters define the frequency or speed range either side of the programmed skip reference, over which references are rejected. The actual reject band is therefore twice that programmed in these parameters, the skip reference parameters defining the centre of the band. When the selected reference is within a band the lower limit of the band is passed through to the ramps such that reference is always less than demanded.

1.35	Reference in rejection zone															
Coding	Bit	SP	FI	DE	Txt	VM	DP	ND	RA	NC	NV	PT	US	RW	BU	PS
	1							1		1		1				
Update rate	5ms															

This parameter indicates that the selected reference is within one of the skip frequency regions such that the motor speed is not as demanded.

1.36	Analog reference 1															
1.37	Analog reference 2															
Coding	Bit	SP	FI	DE	Txt	VM	DP	ND	RA	NC	NV	PT	US	RW	BU	PS
						1	1	1		1						
Range	±1500.0Hz															
Update rate	5ms															

These parameters are made available for control by analog inputs which are required to be frequency references.

The programmed input is automatically scaled such that 100.0% input corresponds to the set maximum speed (Pr 1.06 or Pr 21.01). Also the 0% input level corresponds to the minimum speed level (Pr 1.07 or Pr 21.02) if bipolar (Pr 1.10) is not selected.

1.38	Percentage trim															
Coding	Bit	SP	FI	DE	Txt	VM	DP	ND	RA	NC	NV	PT	US	RW	BU	PS
							1			1				1		
Range	±100.0%															
Default	0.0															
Update rate	5ms															

See Pr 1.09.

1.39 to 1.40	Unused parameters															
---------------------	--------------------------	--	--	--	--	--	--	--	--	--	--	--	--	--	--	--

1.41	Analog reference 2 select															
1.42	Preset reference select															
1.43	Keypad reference select															
1.44	Precision reference select															
1.45	Preset select bit 0															
1.46	Preset select bit 1															
1.47	Preset select bit 2															
Coding	Bit	SP	FI	DE	Txt	VM	DP	ND	RA	NC	NV	PT	US	RW	BU	PS
	1									1				1		
Default	0															
Update rate	5ms															

These bits are provided for control by logic input terminals for external reference selection (see Pr 1.14 on page 26, and Pr 1.15 on page 27).

Pr 1.41 Analog reference 2 select (lowest priority)

Pr 1.42 Preset reference select

Pr 1.43 Keypad reference select

Pr 1.44 Precision reference select (highest priority)

If more than one of these parameters is active, the highest priority take precedence.

1.48	Unused parameter															
-------------	-------------------------	--	--	--	--	--	--	--	--	--	--	--	--	--	--	--

1.49	Reference selected indicator															
Coding	Bit	SP	FI	DE	Txt	VM	DP	ND	RA	NC	NV	PT	US	RW	BU	PS
								1		1		1			1	
Range	1 to 5															
Update rate	5ms															

Indicates the reference currently being selected.

- 1: Analog reference 1 selected
- 2: Analog reference 2 selected
- 3: Preset reference selected
- 4: Keypad reference selected
- 5: precision reference selected

1.50	Preset reference selected indicator															
Coding	Bit	SP	FI	DE	Txt	VM	DP	ND	RA	NC	NV	PT	US	RW	BU	PS
								1		1		1			1	
Range	1 to 8															
Update rate	5ms															

Indicates the preset currently being selected. If Pr 1.49 = 1 or 2 then a value of 1 indicates that one of the analog references is being selected.

1.51	Power-up keypad reference															
Coding	Bit	SP	FI	DE	Txt	VM	DP	ND	RA	NC	NV	PT	US	RW	BU	PS
					1								1	1	1	
Range	0 to 2															
Default	0															
Update rate	N/A															

Selects the value of the keypad reference on power-up.

Value	Display	Function
0	0	keypad reference is zero
1	LAST	keypad reference is the last used value
2	PrS1	keypad reference is copied from Preset speed 1 (Pr 1.21)

9.3 Menu 2: Ramps

Table 9-4 Menu 2 parameters: single line descriptions

Parameter	Range	Default	Setting	Update Rate
2.01	Post ramp reference	± 1500.0 Hz		21 ms
2.02	Not used			
2.03	Ramp hold	0 or 1	0	128 ms
2.04	Ramp mode select {30}	0 to 3	1	B
2.05	Not used			
2.06	S ramp enable	0 or 1	0	B
2.07	S ramp acceleration limit	0.0 to 300.0 s ² /100 Hz	3.1	B
2.08	Standard ramp voltage	0 to DC_VOLTAGE_SET_MAX V	200 V drive: 375 400 V drive: 750 (EUR) 775 (USA)	B
2.09	Not used			
2.10	Acceleration rate selector	0 to 9	0	5 ms
2.11	Acceleration rate 1 {03}	0.0 to 3200.0 s/100 Hz	5.0	5 ms
2.12	Acceleration rate 2	0.0 to 3200.0 s/100 Hz	5.0	5 ms
2.13	Acceleration rate 3	0.0 to 3200.0 s/100 Hz	5.0	5 ms
2.14	Acceleration rate 4	0.0 to 3200.0 s/100 Hz	5.0	5 ms
2.15	Acceleration rate 5	0.0 to 3200.0 s/100 Hz	5.0	5 ms
2.16	Acceleration rate 6	0.0 to 3200.0 s/100 Hz	5.0	5 ms
2.17	Acceleration rate 7	0.0 to 3200.0 s/100 Hz	5.0	5 ms
2.18	Acceleration rate 8	0.0 to 3200.0 s/100 Hz	5.0	5 ms
2.19	Jog acceleration rate	0.0 to 3200.0 s/100 Hz	0.2	5 ms
2.20	Deceleration rate selector	0 to 9	0	5 ms
2.21	Deceleration rate 1 {04}	0.0 to 3200.0 s/100 Hz	10.0	5 ms
2.22	Deceleration rate 2	0.0 to 3200.0 s/100 Hz	10.0	5 ms
2.23	Deceleration rate 3	0.0 to 3200.0 s/100 Hz	10.0	5 ms
2.24	Deceleration rate 4	0.0 to 3200.0 s/100 Hz	10.0	5 ms
2.25	Deceleration rate 5	0.0 to 3200.0 s/100 Hz	10.0	5 ms
2.26	Deceleration rate 6	0.0 to 3200.0 s/100 Hz	10.0	5 ms
2.27	Deceleration rate 7	0.0 to 3200.0 s/100 Hz	10.0	5 ms
2.28	Deceleration rate 8	0.0 to 3200.0 s/100 Hz	10.0	5 ms
2.29	Jog deceleration rate	0.0 to 3200.0 s/100 Hz	0.2	5 ms
2.30	Acceleration selected indicator	1 to 8	1	5 ms
2.31	Acceleration selected indicator	1 to 8	1	5 ms
2.32	Acceleration select bit 0	0 or 1	0	5 ms
2.33	Acceleration select bit 1	0 or 1	0	5 ms
2.34	Acceleration select bit 2	0 or 1	0	5 ms
2.35	Deceleration select bit 0	0 or 1	0	5 ms
2.36	Deceleration select bit 1	0 or 1	0	5 ms
2.37	Deceleration select bit 2	0 or 1	0	5 ms
2.38	Not used			
2.39	Ramp rate units	0 or 2	1	B

Figure 9-5 Menu 2A logic diagram

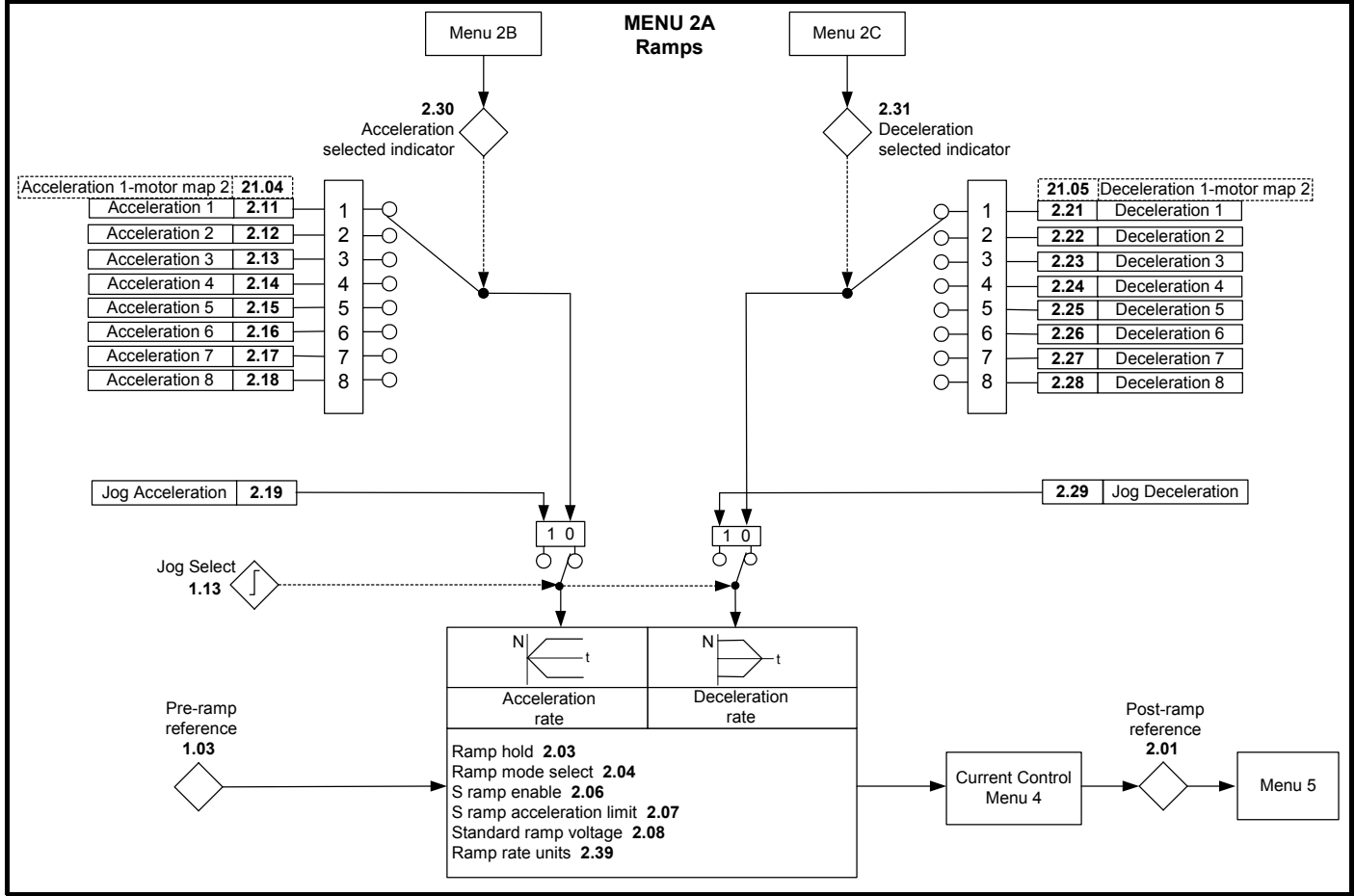

Figure 9-6 Menu 2B logic diagram

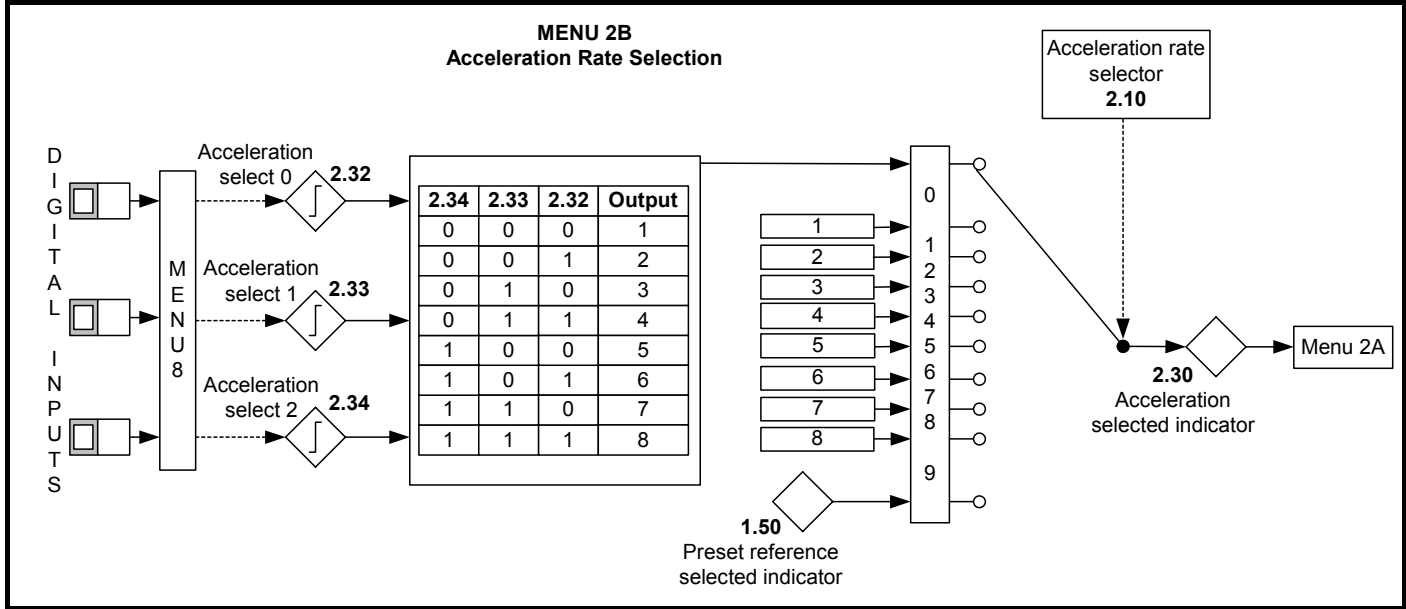
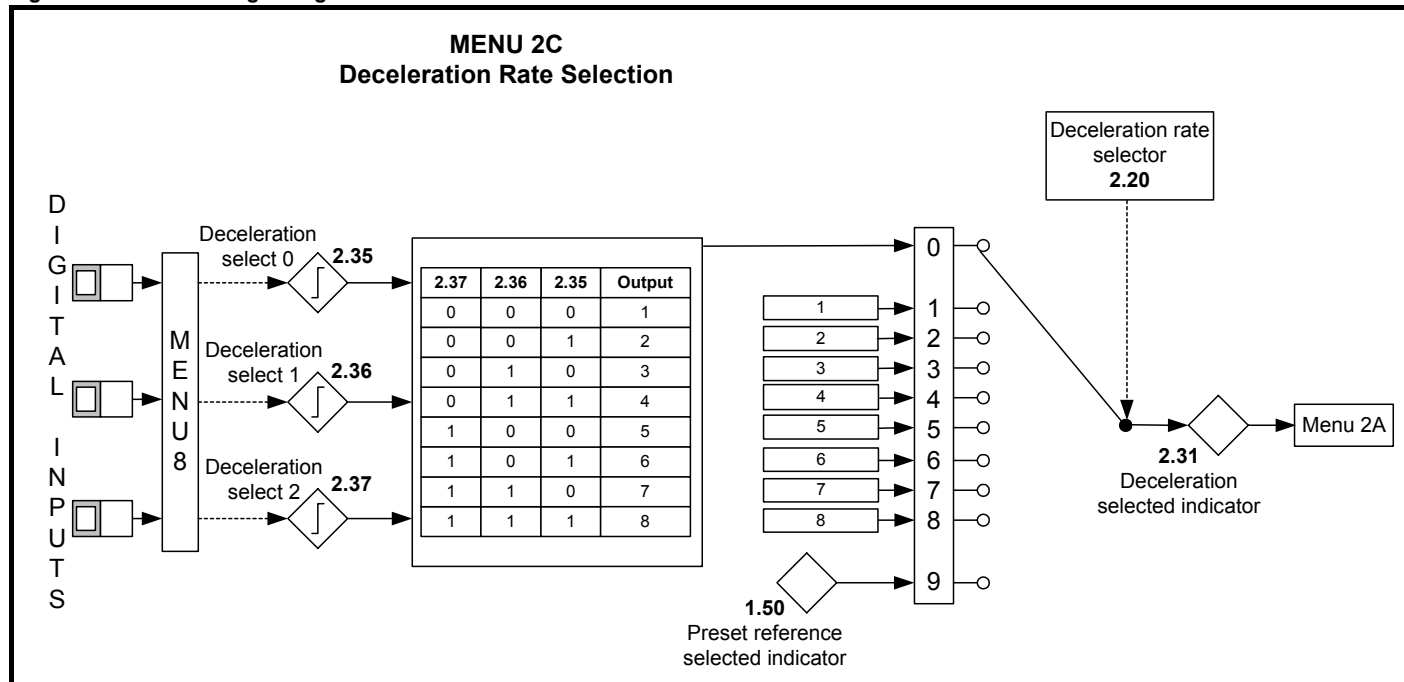

Figure 9-7 Menu 2C logic diagram



2.01	Post ramp reference															
Coding	Bit	SP	FI	DE	Txt	VM	DP	ND	RA	NC	NV	PT	US	RW	BU	PS
			1			1	1	1		1		1				
Range	±1500.0Hz															
Update rate	21ms															

Although the range for scaling purposes is ±1500 Hz, the actual parameter value can be increased beyond this range by the current limit controller (up to 20% > than the maximum frequency).

2.02	Unused parameter															
-------------	-------------------------	--	--	--	--	--	--	--	--	--	--	--	--	--	--	--

2.03	Ramp hold															
Coding	Bit	SP	FI	DE	Txt	VM	DP	ND	RA	NC	NV	PT	US	RW	BU	PS
	1												1	1		
Default	0															
Update rate	128ms															

- 0: Ramp hold disabled
- 1: Ramp hold enabled

If this bit is set the ramp will be held. If S ramp is enabled the acceleration will ramp towards zero causing the ramp output to curve towards a constant speed. If a drive stop is demanded the ramp hold function is disabled.

2.04	Ramp mode select															
Coding	Bit	SP	FI	DE	Txt	VM	DP	ND	RA	NC	NV	PT	US	RW	BU	PS
													1	1	1	
Range	0 to 3															
Default	1															
Update rate	Background															

This parameter has 4 settings as follows:

- 0: Fast ramp
- 1: Standard ramp with normal motor voltage
- 2: Standard ramp with high motor voltage
- 3: Fast ramp with high motor volts

The acceleration ramp is not affected by the ramp mode, and the ramp output will rise at the programmed acceleration rate (subject to the current limits programmed).

Fast Ramp

In modes 0 and 3, the output of the ramp will fall at the programmed deceleration rate (subject to the current limits programmed).

Standard Ramp

In modes 1 & 2, the voltage rising to the standard ramp level (Pr **2.08**) causes a proportional controller to operate, the output of which changes the demanded current in the motor. As the controller regulates the bus voltage, the motor decelerates at a faster and faster rate as it approaches zero speed. When the motor deceleration rate reaches the programmed deceleration rate the controller ceases to operate and the drive continues to decelerate at the programmed rate. If the standard ramp voltage (Pr **2.08**) is set lower than the nominal DC bus level the drive will not decelerate but will coast to rest.

The current demand is fed to the frequency changing current controller and therefore the gain parameters, Pr **4.13** and Pr **4.14** must be set up for optimum control.

Figure 9-8

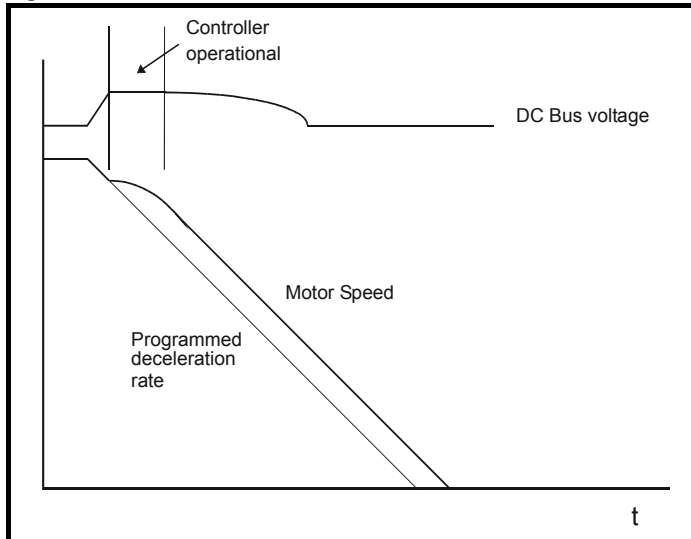

In modes 0 and 1 the motor voltage is correctly set according to the motor rated voltage parameter, while in modes 2 and 3 the motor voltage is allowed to go up to a factor of 1.2 times its normal value during deceleration. This higher voltage saturates the motor which increases the losses in the motor and therefore reduces the amount of energy transferring from the motor to the DC bus for a given deceleration rate. For a given amount of energy being dissipated by the drive at the regulated DC bus level, modes 2 and 3 will allow a faster deceleration than modes 0 and 1, providing that the motor can stand the extra losses being dissipated in it.

NOTE

Mode 0 is normally selected when using a braking resistor (mode 3 can be selected if desired but will cause the motor to heat up more due to the higher losses in the motor when compared to mode 0)

2.05 Unused parameter

2.06	S ramp enable															
Coding	Bit	SP	FI	DE	Txt	VM	DP	ND	RA	NC	NV	PT	US	RW	BU	PS
	1												1	1		
Default	0															
Update rate	Background															

- 0: S ramp disabled
- 1: S ramp enabled

Setting this parameter enables the S ramp function. S ramp is disabled during deceleration when the standard ramp voltage controller is active. When the motor is accelerated again after decelerating in standard ramp the acceleration ramp used by the S ramp function is reset to zero.

NOTE

The S ramp function is only available if the acceleration and deceleration rates are specified in s/100Hz (Pr 2.39 = 1).

2.07	S ramp acceleration limit															
Coding	Bit	SP	FI	DE	Txt	VM	DP	ND	RA	NC	NV	PT	US	RW	BU	PS
							1						1	1	1	
Range	0.0 to 300.0s ² /100Hz															
Default	3.1															
Update rate	Background															

This parameter defines the maximum rate of change of acceleration that the drive will operate with.

The default values have been chosen such that for the default ramps and maximum speed, the curved parts of the S will be 25% of the original ramp if S ramp is enabled.

Figure 9-9

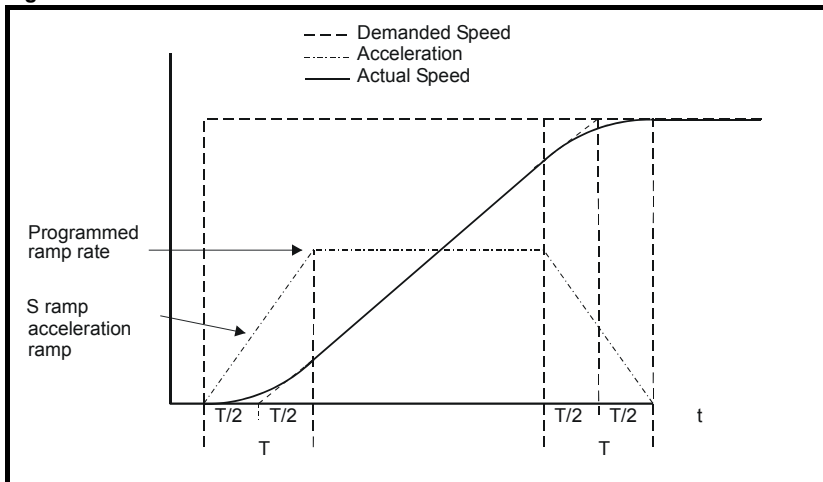

Since the ramp rate is defined in s/100Hz (s/1000Hz when Pr 2.39 = 0) and the S ramp parameter is defined in s²/100Hz (s²/1000Hz when Pr 2.39 = 0), the time T for the 'curved' part of the S can be determined quite easily by dividing the two variables thus:

$$T = S \text{ ramp rate of change} / \text{Ramp rate}$$

Enabling S ramp increases the total ramp time by the period T since an additional T/2 is added to each end of the ramp in producing the S.

2.08	Standard ramp voltage															
Coding	Bit	SP	FI	DE	T _{xt}	VM	DP	ND	RA	NC	NV	PT	US	RW	BU	PS
					1				1				1	1	1	
Range	0 to DC_VOLTAGE_SET_MAX V															
Default	200V rating drive: 375 400V rating drive: EUR: 750, USA: 775															
Update rate	Background															

This voltage is used as the level for standard ramp modes. If it is set too low the machine will coast to rest, and if it is set too high and no braking resistor is used it may trip on OV. The minimum level should be greater than the voltage produced on the DC bus by the highest supply voltage.

Normally the DC bus voltage will be approximately the rms supply voltage x $\sqrt{2}$

NOTE

If the output frequency does not decrease in 10 seconds after the drive has been given a stop command, the drive will disable. This can occur at low speeds with long cables on a soft supply.

2.09	Unused parameter
------	------------------

2.10	Acceleration rate selector															
Coding	Bit	SP	FI	DE	T _{xt}	VM	DP	ND	RA	NC	NV	PT	US	RW	BU	PS
													1	1	1	
Range	0 to 9															
Default	0															
Update rate	5ms															

The acceleration rate is selected as follows.

- 0** Ramp rate selection by terminal input
- 1 to 8** Ramp rate defined by parameter number, i.e. 1 = Pr 2.11, 2 = Pr 2.12, etc.
- 9** Ramp rate selection by parameter Pr 1.50

When parameter Pr 2.10 is set to 0 the acceleration ramp rate selected depends on the state of bit parameters Pr 2.32 to Pr 2.34. These bits are for control by digital inputs such that ramp rates can be selected by external control. The ramp rate selected depends on the binary code generated by these bits as follows:

Pr 2.34	Pr 2.33	Pr 2.32	Ramp defined by
0	0	0	Pr 2.11
0	0	1	Pr 2.12
0	1	0	Pr 2.13
0	1	1	Pr 2.14
1	0	0	Pr 2.15
1	0	1	Pr 2.16
1	1	0	Pr 2.17
1	1	1	Pr 2.18

When parameter Pr 2.10 is set to 9 the appropriate acceleration rate is automatically selected depending on the value of parameter Pr 1.50, and so an acceleration rate can be programmed to operate with each reference. Since the new ramp rate is selected with the new reference, the acceleration applies towards the selected preset if the motor needs to accelerate to reach the preset.

2.11	Acceleration rate 1															
2.12	Acceleration rate 2															
2.13	Acceleration rate 3															
2.14	Acceleration rate 4															
2.15	Acceleration rate 5															
2.16	Acceleration rate 6															
2.17	Acceleration rate 7															
2.18	Acceleration rate 8															
Coding	Bit	SP	FI	DE	Txt	VM	DP	ND	RA	NC	NV	PT	US	RW	BU	PS
							1						1	1	1	
Range	0 to 3200.0s/100 Hz (or s/10Hz or s/1000Hz if Pr 2.39 = 0 or 2)															
Default	5.0															
Second motor parameter	Pr 21.04 for parameter Pr 2.11 only															
Update rate	5ms															

NOTE

When switching between preset speeds and using the preset acceleration ramps, the acceleration ramp used is the one associated to the target preset speed, i.e. if switching from preset speed 3 to preset speed 4 acceleration rate 4 would be used.

If enabling and running to a preset speed using the Run Forward and Run Reverse terminals, the preset acceleration ramp used will be the one associated to the preset speed being run to.

2.19	Jog acceleration rate															
Coding	Bit	SP	FI	DE	Txt	VM	DP	ND	RA	NC	NV	PT	US	RW	BU	PS
							1						1	1	1	
Range	0 to 3200.0s/100 Hz (or s/10Hz or s/1000Hz if Pr 2.39 = 0 or 2)															
Default	0.2															
Update rate	5ms															

The jog acceleration rate is only used when accelerating towards the jog reference and when changing the jog reference.

There are eight acceleration rates programmable for normal operation, plus one for jogging. The ramp rates are expressed as a time for a change of 100 Hz on the ramp output, therefore with a programmed ramp time of 5 seconds the ramp output will reach 50 Hz from 0 in 2.5 seconds (depending on the setting of Pr 2.39).

2.20	Deceleration rate selector															
Coding	Bit	SP	FI	DE	Txt	VM	DP	ND	RA	NC	NV	PT	US	RW	BU	PS
													1	1	1	
Range	0 to 9															
Default	0															
Update rate	5ms															

The deceleration rate is selected as follows.

- 0 Ramp rate selection by terminal input
- 1 - 8 Ramp rate defined by parameter number, i.e. 1 = Pr 2.21, 2 = Pr 2.22, etc.
- 9 Ramp rate selection by parameter Pr 1.50

When parameter Pr 2.20 is set to 0 the deceleration ramp rate selected depends on the state of bit parameters Pr 2.35 to Pr 2.37. These bits are for control by digital inputs such that ramp rates can be selected by external control. The ramp rate selected depends on the binary code generated by these bits as follows:

Pr 2.37	Pr 2.36	Pr 2.35	Ramp defined by
0	0	0	Pr 2.21
0	0	1	Pr 2.22
0	1	0	Pr 2.23
0	1	1	Pr 2.24
1	0	0	Pr 2.25
1	0	1	Pr 2.26
1	1	0	Pr 2.27
1	1	1	Pr 2.28

When parameter Pr 2.20 is set to 9 the appropriate deceleration rate is automatically selected depending on the value of parameter Pr 1.50, and so an deceleration rate can be programmed to operate with each reference. Since the new ramp rate is selected with the new reference, the deceleration applies towards the selected preset if the motor needs to decelerate to reach the preset.

2.21	Deceleration rate 1															
2.22	Deceleration rate 2															
2.23	Deceleration rate 3															
2.24	Deceleration rate 4															
2.25	Deceleration rate 5															
2.26	Deceleration rate 6															
2.27	Deceleration rate 7															
2.28	Deceleration rate 8															
Coding	Bit	SP	FI	DE	Txt	VM	DP	ND	RA	NC	NV	PT	US	RW	BU	PS
							1						1	1	1	
Range	0 to 3200.0 s/100 Hz (or s/10Hz or s/1000Hz if Pr 2.39 = 0 or 2)															
Default	10.0															
Second motor parameter	Pr 21.05 for parameter Pr 2.21 only															
Update rate	5ms															

NOTE

When switching between preset speeds and using the preset acceleration ramps, the acceleration ramp used is the one associated to the target preset speed, i.e. if switching from preset speed 3 to preset speed 4 acceleration rate 4 would be used.
If enabling and running to a preset speed using the Run Forward and Run Reverse terminals, the preset acceleration ramp used will be the one associated to the preset speed being run to.

2.29	Deceleration rate selector															
Coding	Bit	SP	FI	DE	Txt	VM	DP	ND	RA	NC	NV	PT	US	RW	BU	PS
							1						1	1	1	
Range	0 to 3200.0 s/100 Hz (or s/10Hz or s/1000Hz if Pr 2.39 = 0 or 2)															
Default	0.2															
Update rate	5ms															

The jog deceleration rate is only used when the drive is changing speed because the jog reference has changed or to stop from the jog reference. It is not used to go from the jog to the run state. This prevents the fast ramps normally used with jog from being used when changing between running and jogging.

There are eight acceleration rates programmable for normal operation, plus one for jogging. The ramp rates are expressed as a time for a change of 100 Hz on the ramp output, therefore with a programmed ramp time of 5 seconds the ramp output will reach 50 Hz from 0 in 2.5 seconds (depending on the setting of Pr 2.39).

2.30	Acceleration selected indicator															
Coding	Bit	SP	FI	DE	Txt	VM	DP	ND	RA	NC	NV	PT	US	RW	BU	PS
								1		1		1			1	
Range	1 to 8															
Update rate	5ms															

2.31	Deceleration selected indicator															
Coding	Bit	SP	FI	DE	Txt	VM	DP	ND	RA	NC	NV	PT	US	RW	BU	PS
								1		1		1			1	
Range	1 to 8															
Update rate	5ms															

2.32	Acceleration select bit 0															
2.33	Acceleration select bit 1															
2.34	Acceleration select bit 2															
2.35	Deceleration select bit 0															
2.36	Deceleration select bit 1															
2.37	Deceleration select bit 2															
Coding	Bit	SP	FI	DE	Txt	VM	DP	ND	RA	NC	NV	PT	US	RW	BU	PS
	1									1				1		
Default	0															
Update rate	5ms															

These bits are provided for control by logic input terminals for external ramp selection (see Pr 2.10 on page 36 & Pr 2.20 on page 37).

2.38	Unused parameter															
-------------	-------------------------	--	--	--	--	--	--	--	--	--	--	--	--	--	--	--

2.39	Ramp rate units															
Coding	Bit	SP	FI	DE	Txt	VM	DP	ND	RA	NC	NV	PT	US	RW	BU	PS
													1	1		
Range	0 to 2															
Default	1															
Update rate	Background															

This parameter can select 3 different ramp rates, as follows:

- 0: s/1000Hz
- 1: s/100Hz(default)
- 2: s/10Hz

Therefore, for 0 to 50Hz:

- 0: Maximum ramp time of 160 seconds, resolution 0.005s
- 1: Maximum ramp time of 1600 seconds, resolution 0.05s
- 2: Maximum ramp time of 16000 seconds (>4 hours), resolution 0.5s

Example:

If Pr 2.11 Acceleration rate 1 is set to 10, the following acceleration time would apply according to the value of Pr 2.39:

Pr 2.39	0 to 100Hz	0 to 50Hz
0	1s	0.5s
1	10s	5s
2	100s	50s

9.4 Menu 3: Speed sensing thresholds and frequency input and output

Table 9-5 Menu 3 parameters: single line descriptions

Parameter		Range	Default	Setting	Update Rate
3.01	Not used				
3.02	Not used				
3.03	Not used				
3.04	Not used				
3.05	Zero speed threshold	0.0 to 20.0 Hz	1.0		BR
3.06	At speed window	0.0 to 20.0 Hz	1.0		BR
3.07	Not used				
3.08	Not used				
3.09	Not used				
3.10	Not used				
3.11	Not used				
3.12	Not used				
3.13	Not used				
3.14	Not used				
3.15	Not used				
3.16	Not used				
3.17	Frequency output or PWM output scaling	0.000 to 4.000	1.000		BR
3.18	Maximum output frequency	0 to 3	2		B
3.19	Not used				
3.20	Not used				
3.21	Not used				
3.22	Hard frequency reference	±1500.0 Hz	0.0		128 ms
3.23	Hard frequency reference selector	0 or 1	0		5 ms
3.24	Not used				
3.25	Not used				
3.26	Not used				
3.27	Not used				
3.28	Not used				
3.29	Position	0 to 9999			B
3.30	Not used				
3.31	Not used				
3.32	Position counter reset	0 or 1	0		B
3.33	Position scaling numerator	0.000 to 1.000	1.000		B
3.34	Position scaling denominator	0.0 to 100.0	1.0		B
3.35	Not used				
3.36	Not used				
3.37	Not used				
3.38	Not used				
3.39	Not used				
3.40	Not used				
3.41	Not used				
3.42	Not used				
3.43	Maximum reference frequency	0.0 to 50.0 kHz	10.0		B
3.44	Frequency reference scaling	0.000 to 4.000	1.000		B
3.45	Frequency reference	0.0 to 100.0%			5 ms

Figure 9-10 Menu 3A logic diagram

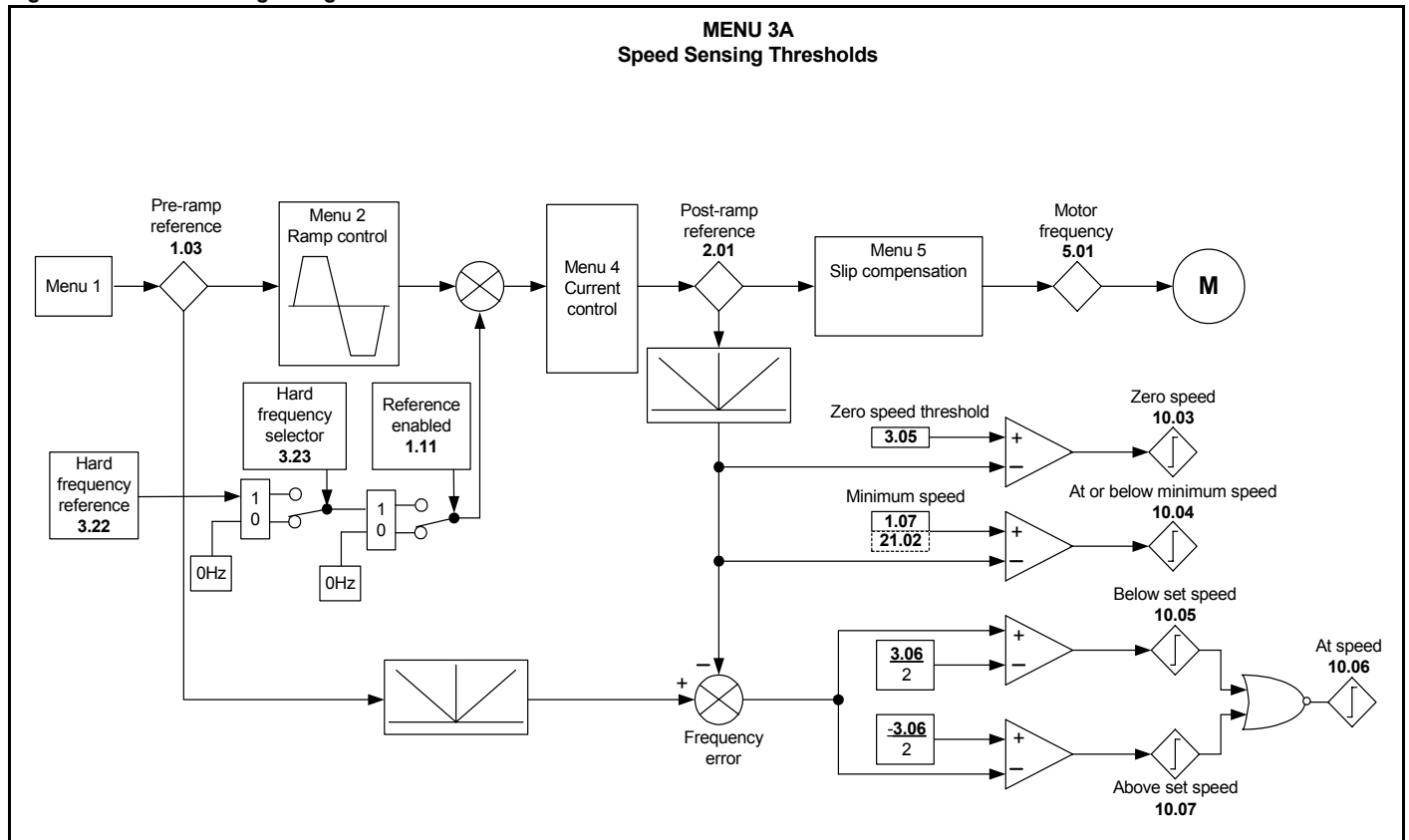
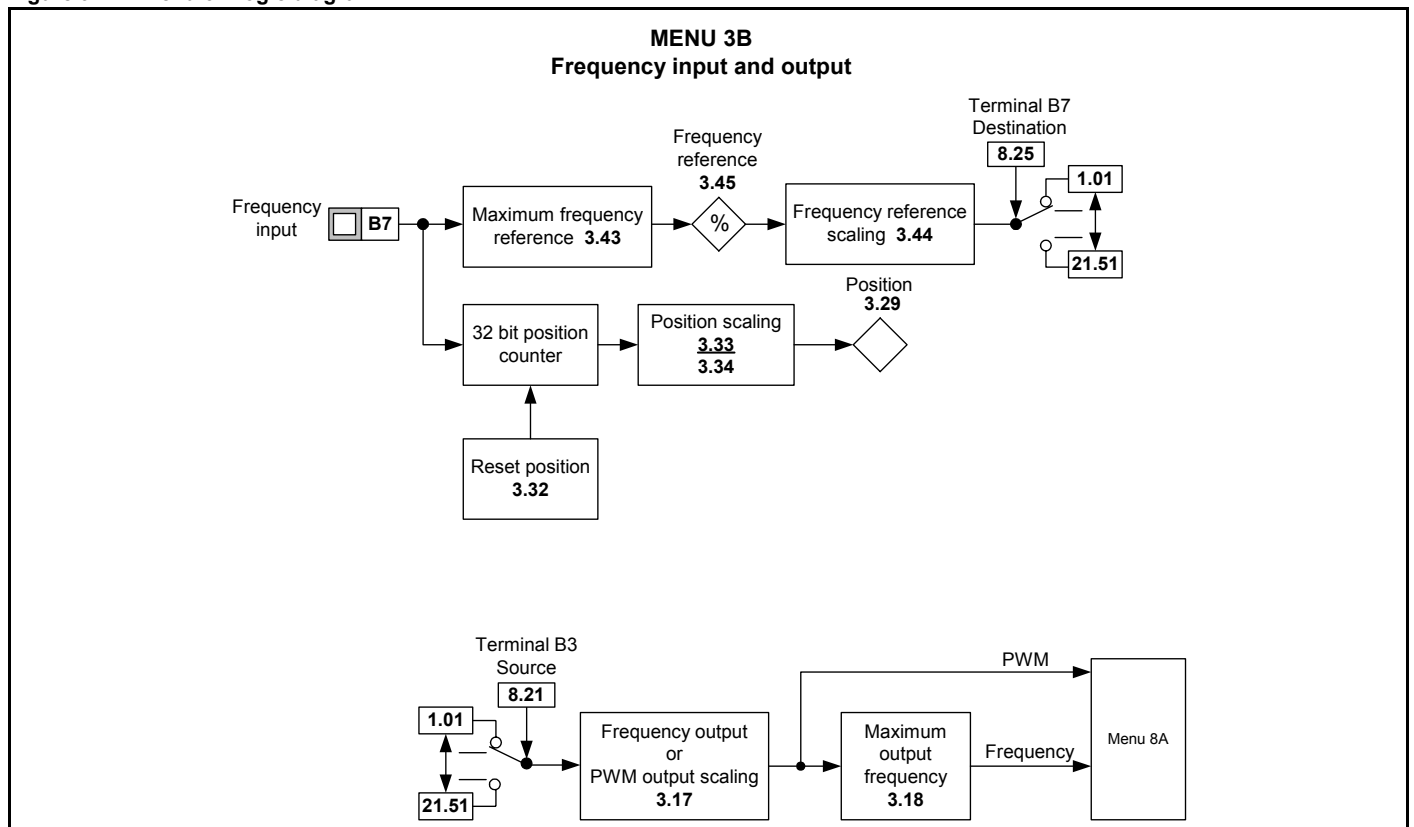

Figure 9-11 Menu 3B logic diagram



Frequency input and output

The frequency input is used as a speed reference. In some applications, a frequency input from a controller is used in preference to a 0 to +10V or 4 to 20mA signal.

This frequency input is converted into a frequency reference percentage (Pr 3.45) and this percentage value is used to provide the speed reference (as Pr 7.01 and Pr 7.02 in Menu 7).

This frequency input cannot be used for frequency slaving.

The frequency input and output are not 'locked' together or synchronised within the drive. The frequency input is used as a speed reference and from this input, the software calculates the correct frequency to put on to the output.

3.01 to 3.04 Unused parameters

3.05	Zero speed threshold															
Coding	Bit	SP	FI	DE	Txt	VM	DP	ND	RA	NC	NV	PT	US	RW	BU	PS
							1						1	1	1	
Range	0.0 to 20.0 Hz															
Default	1.0															
Update rate	Background read															

If the post ramp reference (Pr 2.01) is at or below the level defined by this parameter in either direction the Zero speed flag (Pr 10.03) is 1, otherwise the flag is 0.

3.06	At speed window															
Coding	Bit	SP	FI	DE	Txt	VM	DP	ND	RA	NC	NV	PT	US	RW	BU	PS
							1						1	1	1	
Range	0.0 to 20.0 Hz															
Default	1.0															
Update rate	Background read															

This parameter defines the 'At speed' window which is the boundary around the set speed point in which an 'At speed' indication is given (Pr 10.06 = 1). The 'At speed' window is thus defined as Set speed \pm (Pr 3.06 / 2).

The speed detector system also includes an overspeed trip. The level cannot be set by the user, but the drive produces an overspeed trip if the post ramp reference (Pr 2.01) exceeds 1.2 x (Maximum frequency).

3.07 to 3.16 Unused parameters

3.17	Frequency output or PWM output scaling															
Coding	Bit	SP	FI	DE	Txt	VM	DP	ND	RA	NC	NV	PT	US	RW	BU	PS
							3						1	1	1	
Range	0.000 to 4.000															
Default	1.000															
Update rate	Background read															

Scale factor applied to the frequency or PWM output.

3.18	Maximum output frequency															
Coding	Bit	SP	FI	DE	Txt	VM	DP	ND	RA	NC	NV	PT	US	RW	BU	PS
					1								1	1	1	
Range	0 to 3															
Default	2 (5 kHz)															
Update rate	Background															

Defines the maximum frequency required at the frequency output. The choice of maximum output frequency depends on the requirement of the output. Due to limitations in the hardware, higher output frequencies do not offer the best resolution at the top end of the frequency range.

Pr 3.18	Fmax (kHz)	Resolution at Fmax
0	1	10 bit
1	2	9
2	5	8
3	10	7.7

3.19 to 3.21 Unused parameters

3.22	Hard frequency reference															
Coding	Bit	SP	FI	DE	Txt	VM	DP	ND	RA	NC	NV	PT	US	RW	BU	PS
						1	1						1	1		
Range	±1500.0 Hz															
Default	0.0															
Update rate	128 ms															

3.23	Hard frequency reference selector															
Coding	Bit	SP	FI	DE	Txt	VM	DP	ND	RA	NC	NV	PT	US	RW	BU	PS
	1												1	1		
Default	0															
Update rate	5 ms															

- 0: Hard frequency reference selector disabled
- 1: Hard frequency reference selector enabled

The hard frequency reference is a reference value which does not pass through the ramp system (Menu 2). It is added to the normal post ramp speed reference. The hard speed reference is selected when Pr 3.23 = 1.

NOTE

Large changes in value may cause the drive to trip OI.AC.

3.24 to 3.28 Unused parameters

3.29	Position															
Coding	Bit	SP	FI	DE	Txt	VM	DP	ND	RA	NC	NV	PT	US	RW	BU	PS
								1		1		1			1	1
Range	0 to 9999															
Update rate	Background															

Indicates the current value of the position counter.

3.30 to 3.31 Unused parameters

3.32	Position counter reset															
Coding	Bit	SP	FI	DE	Txt	VM	DP	ND	RA	NC	NV	PT	US	RW	BU	PS
	1									1				1		
Default	0															
Update rate	Background															

3.33	Position scaling numerator															
Coding	Bit	SP	FI	DE	Txt	VM	DP	ND	RA	NC	NV	PT	US	RW	BU	PS
							3						1	1	1	
Range	0.000 to 1.000															
Default	1.000															
Update rate	Background															

3.34	Position scaling denominator															
Coding	Bit	SP	FI	DE	Txt	VM	DP	ND	RA	NC	NV	PT	US	RW	BU	PS
							1						1	1	1	
Range	0.0 to 100.0															
Default	1.0															
Update rate	Background															

Pr 3.33 and Pr 3.44 are used to scale the pulse counter down to the required position units. The multiplying factor applied to the counter is defined as:

Pr3.33
Pr3.34

3.35 to 3.42	Unused parameters
--------------	-------------------

3.43	Maximum reference frequency															
Coding	Bit	SP	FI	DE	Txt	VM	DP	ND	RA	NC	NV	PT	US	RW	BU	PS
							1						1	1	1	
Range	0.0 to 50.0 kHz															
Default	10.0															
Update rate	Background															

Defines the maximum frequency expected at the frequency input. The time the frequency is measured over is defined by:

$$\text{Measurement time} = \frac{2048}{\text{Maximum reference frequency}}$$

With a maximum measurement time of 0.341 seconds.

2048 is used to give the measurement more stability. The output is 10 bits.

Maximum reference frequency of less than 6 kHz will have a lower resolution.

When Pr 8.35 is set to 3 (Frequency input mode with precision) the measured time is fixed at 0.341 seconds. This gives a 12 bit input for maximum reference frequency of 15 kHz and greater. Pr 1.19 is automatically updated with the 2 LSBs.

3.44	Frequency reference scaling															
Coding	Bit	SP	FI	DE	Txt	VM	DP	ND	RA	NC	NV	PT	US	RW	BU	PS
							3						1	1	1	
Range	0.000 to 4.000															
Default	1.000															
Update rate	Background															

Scale factor applied to the frequency reference.

3.45	Frequency reference															
Coding	Bit	SP	FI	DE	Txt	VM	DP	ND	RA	NC	NV	PT	US	RW	BU	PS
							1	1		1		1			1	
Range	0.0 to 100.0 %															
Update rate	5 ms															

Indicates the frequency input value.

9.5 Menu 4: Current control

Table 9-6 Menu 4 parameters: single line descriptions

Parameter		Range	Default	Setting	Update Rate
4.01	Current magnitude (motor current)	0 to DRIVE_CURRENT_MAX A			B
4.02	Motor active current	±DRIVE_CURRENT_MAX A			B
4.03	Not used				
4.04	Current demand	± TORQUE_PROD_ CURRENT_MAX %			B
4.05	Not used				
4.06	Not used				
4.07	Symmetrical current limit	0 to MOTOR1_CURRENT_LIMI T_MAX %	165.0		B
4.08	Torque reference	± USER_CURRENT_ MAX %	0.0		B
4.09	Not used				
4.10	Not used				
4.11	Torque mode selector	0 or 1	0		B
4.12	Not used				
4.13	Current controller Kp gain	0 to 250	20		B
4.14	Current controller Ki gain	0 to 250	40		B
4.15	Thermal time constant	0 to 250	89		B
4.16	Thermal protection mode	0 or 1	0		B
4.17	Reactive current	±DRIVE_CURRENT_MAX A			B
4.18	Overriding current limit	0.0 to TORQUE_PROD_ CURRENT_MAX %			B
4.19	Overload accumulator	0.0 to 100.0%			B
4.20	Percentage load	± USER_CURRENT_ MAX %			B
4.21	Load display units	{22} 0 to 1	0		B
4.22	Not used				
4.23	Not used				
4.24	User current maximum scaling	0.0 to TORQUE_PROD_ CURRENT_MAX %	165.0		B
4.25	Low speed thermal protection mode	0 or 1	0		B
4.26	Percentage torque	± USER_CURRENT_ MAX %			B

Figure 9-12 Menu 4 logic diagram

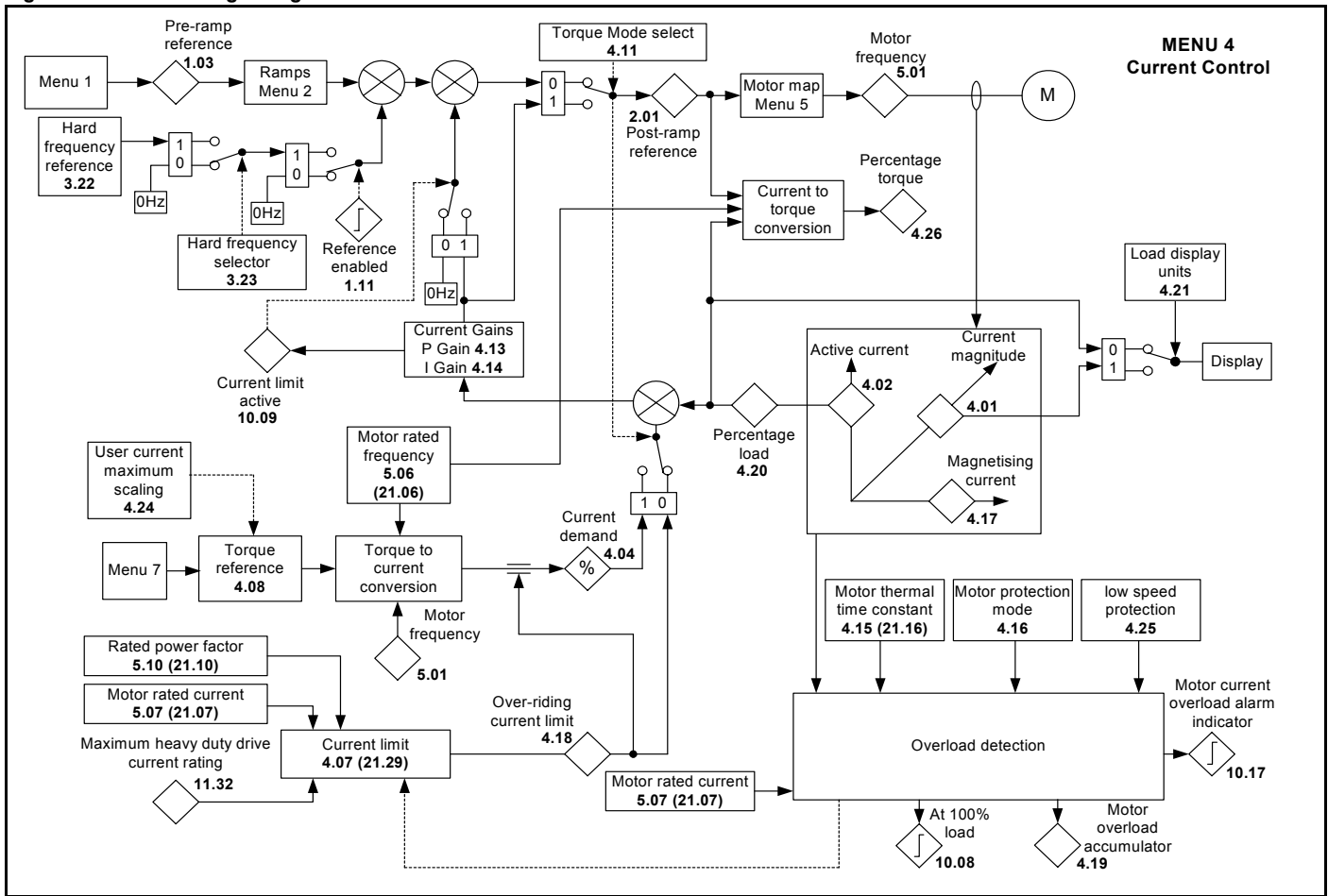

On the larger Commander SK frame sizes, the ratio between maximum continuous current and maximum overload is less than on the smaller drives. This is handled in the software by specifying the 'drives rated current' as maximum current limit level / 1.5, the same as on the smaller drives. The current rating in Pr 11.32 is still the Heavy Duty rating of the drive, but because it is greater than the 'drive rating' figure used by the software, the current limit point will be less than 150% of the rating specified in Pr 11.32.

The motor rated current (Pr 5.07) may be increased above the drive current rating specified in Pr 11.32 up to a limit defined by the Maximum motor rated current. If the motor rated current is above the current rating specified in Pr 11.32, the motor thermal protection scheme is modified (see Pr 4.16).

In the following descriptions the term 'drive rated current' is the one used by the software, not the value in Pr 11.32.

The drive has a current controller to give current limiting in frequency control mode and a torque controller in torque control mode. The active current is controlled by modification of the drive output frequency. Menu 4 provides parameters to set-up the current controller. Additional voltage based current control is provided to limit transients (peak-limit), but there are no user parameters to control this.

The drive operates in the stator flux reference frame under steady state conditions. The absolute maximum motor current is defined by the peak limit system as 1.75 x rated drive current. However, the drive does not normally operate at this level, but uses the peak limit system as protection against over-current trips. Under normal operation the motor current is limited to 1.50 x rated drive current, allowing a safety margin between the maximum normal operating current and the peak limit level.

DRIVE_CURRENT_MAX is full scale current feedback, i.e. rated drive current x 2.0.

The relationship between the voltage and current is shown in the following vector diagram.

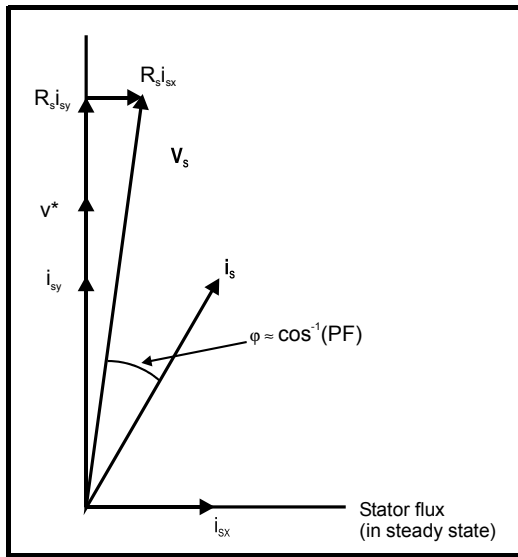

Definitions:

- v_s = motor terminal voltage vector
- i_s = motor current vector
- i_{sy} = y axis component of current
- i_{sx} = x axis component of current
- v^* = no load y axis voltage reference

MOTOR1_CURRENT_LIMIT_MAX is used as the maximum for some parameters such as the user current limits. This is defined in the vector equation as follows (with a maximum of 1000%):

$$\text{MOTOR1_CURRENT_LIMIT_MAX} = \frac{\sqrt{\left[\frac{\text{Maximum current}}{\text{Motor rated current}}\right]^2 + (\text{PF})^2 - 1}}{\text{PF}} \times 100\%$$

Where:

- Motor rated current is given by Pr 5.07
- PF is motor rated power factor given by Pr 5.10
- (MOTOR2_CURRENT_LIMIT_MAX is calculated from the motor map 2 parameters)
- The Maximum current is either (1.5 x Rated drive current) when the rated current set by Pr 5.07 (or Pr 21.07 if motor map 2 is selected) is less than or equal to the Maximum Heavy Duty current rating, otherwise it is (1.1 x Maximum motor rated current).

For example, with a motor of the same rating as the drive and a power factor of 0.85, the maximum current limit is 165.2%.

The above calculation is based on the assumption that the flux producing current (Pr 4.17) in the stator flux reference frame does not vary with load and remains at the level for rated load. This is not the case and the flux producing current will vary as the load is increased. Therefore the maximum current limit may not be reached before the drive reduces the current limit to prevent the peak limit from becoming active.

The rated active and rated magnetising currents are calculated from the power factor (Pr 5.10) and motor rated current (Pr 5.07) as:

- rated active current = power factor x motor rated current
- rated magnetising current = $\sqrt{(1 - \text{power factor}^2)}$ x motor rated current

The drive uses the motor rated current and the power factor at rated load to set up the maximum current limits, scale the current limits correctly and

calculate the rated active and magnetising currents. The user may enter the nameplate values in Pr 5.07 and Pr 5.10 respectively and the drive will operate satisfactorily. Alternatively the drive can perform an auto-tune test on the motor to measure the power factor at rated load by measuring R_s (stationary test), σL_s (stationary test), and L_s (rotating test). See Pr 5.12 on page 60 for details.

4.01	Current magnitude (motor current)															
Coding	Bit	SP	FI	DE	Txt	VM	DP	ND	RA	NC	NV	PT	US	RW	BU	PS
			1			1	2	1		1		1			1	
Range	0 to DRIVE_CURRENT_MAX															
Update rate	Background															

This parameter is the r.m.s. current from each output phase of the drive. The phase currents consist of an active component and a reactive component. The three phase currents can be combined to form a resultant current vector as shown below:

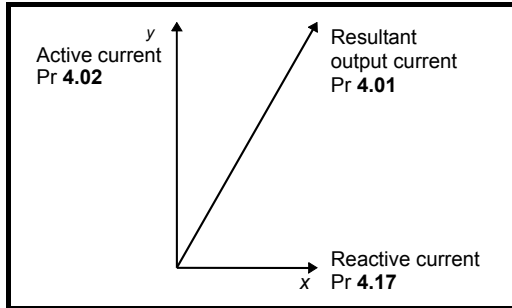

The resultant current magnitude is displayed by this parameter. The active current is the torque producing current, and the reactive current is the magnetising or flux producing current.

4.02	Motor active current															
Coding	Bit	SP	FI	DE	Txt	VM	DP	ND	RA	NC	NV	PT	US	RW	BU	PS
			1			1	2	1		1		1				
Range	±DRIVE_CURRENT_MAX A															
Update rate	Background															

The active current is the torque producing current in a motor drive.

Direction of active current	Direction of rotation	State and direction of rotation	Torque
+	+	Forward accelerating	Motoring (+)
-	+	Forward decelerating or braking	Regeneration (-)
+	-	Reverse decelerating or braking	Regeneration (-)
-	-	Reverse accelerating	Motoring (+)

The diagram above shows the magnetising and active current vectors. These are represented in x and y axes of a reference frame. Pr 4.02 gives the active current which is proportional to the length of the vector in the y axis and equivalent to the active phase current value in amps.

If the drive operates with fixed boost the y axis is aligned with the output voltage. Therefore the magnetising current represents the reactive component of current leaving the drive and the active current represents the real component of current leaving the drive. Therefore the active current produces torque and supplies the losses in the motor.

If the drive operates in vector mode (see Pr 5.14 on page 62) the x axis is aligned with the stator flux in the steady state, and so the active current should be proportional to the torque produced by the machine. The active current will give a good indication of the machine torque over most of the frequency range, however, the accuracy is reduced below 10Hz.

In both cases the relationship between the active current and motor torque will change once the maximum drive output voltage or the rated voltage of the motor set by Pr 5.09 is reached, whichever is the lowest. (Generally the maximum drive output voltage will be just below the r.m.s. line supply voltage.) Once one of these limits is reached the voltage is held constant and the motor flux reduces with frequency. This is referred to as field weakening or constant power operation. In this region the relationship between torque and active current is approximately as follows, where K is a constant related to the motor:

$$\text{Torque} = K \times \text{active current} \times \text{frequency at voltage limit} / \text{actual frequency}$$

Normally the point at which the voltage limit is reached is close to the rated frequency of the motor.

4.03	Unused parameter
-------------	-------------------------

4.04	Current demand															
Coding	Bit	SP	FI	DE	Txt	VM	DP	ND	RA	NC	NV	PT	US	RW	BU	PS
			1			1	1	1		1		1				
Range	±TORQUE_PROD_CURRENT_MAX %															
Update rate	Background															

The current demand is derived from the torque demand. Provided the motor is not field weakened the torque and current demands are the same. In field weakening the current demand is increased with reduced flux:

$$\text{Current demand} = \frac{\text{Output frequency (Pr 5.01)}}{\text{Rated frequency (Pr 5.06)}}$$

The current demand is subject to the current limits.

4.05 to 4.06	Unused parameters
---------------------	--------------------------

4.07	Symmetrical current limit															
Coding	Bit	SP	FI	DE	Txt	VM	DP	ND	RA	NC	NV	PT	US	RW	BU	PS
						1	1		1				1	1	1	
Range	0 to MOTOR1_CURRENT_LIMIT_MAX %															
Default	165.0															
Second motor parameter	Pr 21.29															
Update rate	Background															

This parameter defines the current limit as a percentage of the rated active current. When the motor rated current is set lower than the drive rated current, the maximum value of this parameter increases to allow larger overloads.

Therefore, by setting the motor rated current to a lower value than the drive rated current, it is possible to have a current limit greater than 165%. An absolute maximum current limit of 999.9% is applied.

In frequency control mode (Pr 4.11 = 0), the drive output frequency is modified if necessary to keep the active current within the current limits as shown below:

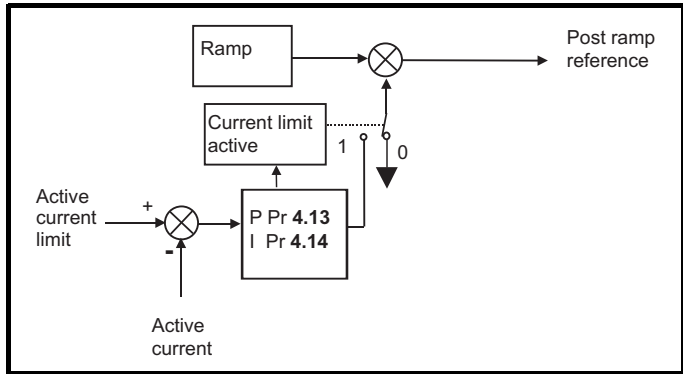

The active current limit is compared with the active current and if the current exceeds the limit the error value passes through the PI controller to give a frequency component which is used to modify the ramp output. The direction of the modification is always to reduce the frequency to zero if the active current is motoring, or to increase the frequency towards the maximum if the current is regenerating. Even when the current limit is active the ramp still operates, therefore the proportional and integral gains (Pr 4.13 and Pr 4.14) must be high enough to counter the effects of the ramp. For method of setting the gains see Pr 4.13 and Pr 4.14 on page 50.

In torque control mode the current demand is limited by the active current limit. For operation of this mode see Pr 4.11 on page 50.

4.08	Torque reference															
Coding	Bit	SP	FI	DE	Txt	VM	DP	ND	RA	NC	NV	PT	US	RW	BU	PS
						1	1						1	1		
Range	±USER_CURRENT_MAX %															
Default	0.0															
Update rate	Background															

This is the main torque reference parameter. A positive value is required for torque to be applied in the forward direction, and a negative value is required for torque to be applied in the reverse direction.

For a negative value, program a digital input to the analog input invert bit. This will give a negative value on the analog input destination parameter.

If operating in torque control, due to small errors in current measurement at low frequencies, with zero torque reference and light loads, the drive may allow the motor to rotate. The direction of rotation while in torque control is determined by the polarity of the torque reference. Therefore, at power-up with zero torque reference and with the drive enabled, the motor may rotate in either direction. This is because any error in the current feedback maybe a positive or negative value. If the error is positive, the motor will rotate in the forward direction and if the error is negative, the motor will rotate in the reverse direction.

If it is necessary to guarantee the direction of rotation at power up while in torque control, a small positive or negative error must be present in Pr 4.08.

4.09 to 4.10 Unused parameters

4.11	Torque mode selector															
Coding	Bit	SP	FI	DE	Txt	VM	DP	ND	RA	NC	NV	PT	US	RW	BU	PS
	1												1	1		
Range	0 or 1															
Default	0															
Update rate	Background															

- 0: Torque mode disabled
- 1: Torque mode enabled

If this parameter is 0 normal frequency control is used.

If this parameter is set to 1 the current demand is connected to the current PI controller giving closed loop torque/current demand as shown below.

The current error is passed through proportional and integral terms to give a frequency reference. In motoring conditions the frequency reference is limited to the maximum frequency set up in menu 1, while for regeneration the frequency reference is allowed to go up to the maximum programmed in menu 1 + 20% to allow for current control close to maximum speed.

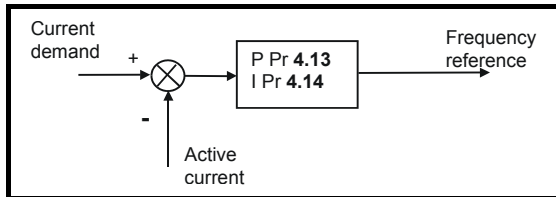

NOTE

This parameter can be changed from 0 to 1 when the drive is still running, the drive does not have to be disabled or stopped etc.

NOTE

When torque control is enabled, slip compensation is automatically disabled to prevent overspeed trips (O.SPd)

4.12 Unused parameter

4.13	Current controller Kp gain															
Coding	Bit	SP	FI	DE	Txt	VM	DP	ND	RA	NC	NV	PT	US	RW	BU	PS
													1	1	1	
Range	0 to 250															
Default	250															
Update rate	Background															

See Pr 4.14 for details.

4.14	Current controller Ki gain															
Coding	Bit	SP	FI	DE	Txt	VM	DP	ND	RA	NC	NV	PT	US	RW	BU	PS
													1	1	1	
Range	0 to 250															
Default	40															
Update rate	Background															

These parameters control the proportional and integral gains of the current controller. As already mentioned the current controller either provides current limits or closed loop torque control by modifying the drive output frequency. The control loop is also used in its torque mode during mains loss, or when the controlled mode standard ramp is active and the drive is decelerating, to regulate the flow of current into the drive. Although the default settings have been chosen to give suitable gains for less demanding applications it may be necessary for the user to adjust the performance of the controller. The following is a guide to setting the gains for different applications.

Current limit operation

The current limits will normally operate with an integral term only, particularly below the point where field weakening begins. The proportional term is

inherent in the loop. The integral term must be increased enough to counter the effect of the ramp which is still active even in current limit. For example, if the drive is operating at constant frequency and is overloaded the current limit system will try to reduce the output frequency to reduce the load. At the same time the ramp will try to increase the frequency back up to the demand level. If the integral gain is increased too far the first signs of instability will occur when operating around the point where field weakening begins. These oscillations can be reduced by increasing the proportional gain. A system has been included to prevent regulation because of the opposite actions of the ramps and the current limit. This can reduce the actual level that the current limit becomes active by 12.5%. This still allows the current to increase up to the current limit set by the user. However the current limit flag (Pr 10.09) could become active up to 12.5% below the current limit depending on the ramp rate used.

Torque control

Again the controller will normally operate with an integral term only, particularly below the point where field weakening begins. The first signs of instability will appear around rated speed, and can be reduced by increasing the proportional gain. The controller can be less stable in torque control mode rather than when it is used for current limiting. This is because load helps to stabilise the controller, and under torque control the drive may operate with light load. Under current limit the drive is often under heavy load unless the current limits are set at a low level.

Mains loss and controlled standard ramp

The DC bus voltage controller becomes active if mains loss detection is enabled and the drive supply is lost or controlled standard ramp is being used and the machine is regenerating. The DC bus controller attempts to hold the DC bus voltage at a fixed level by controlling the flow of current from the drive inverter into its DC bus capacitors. The output of the DC bus controller is a current demand which is fed into the current PI controller as shown below:

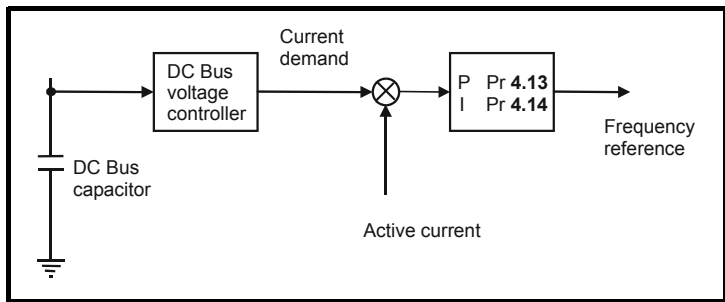

The DC bus controller gain is a function of DC bus capacitance and therefore is fixed internally. It may often be necessary to adjust the current controller gains to obtain the required performance. If the gains are not suitable it is best to set up the drive in torque control first. Set the gains to a value that does not cause instability around the point at which field weakening occurs. Then revert back to open loop speed control in standard ramp mode. To test the controller the supply should be removed whilst the motor is running. It is likely that the gains can be increased further if required because the DC bus voltage controller has a stabilising effect, provided that the drive is not required to operate in torque control mode.

4.15	Thermal time constant															
Coding	Bit	SP	FI	DE	Txt	VM	DP	ND	RA	NC	NV	PT	US	RW	BU	PS
Range	0 to 250 s															
Default	89															
Second motor parameter	Pr 21.16															
Update rate	Background															

See Pr 4.16 for details.

4.16	Thermal protection mode															
Coding	Bit	SP	FI	DE	Txt	VM	DP	ND	RA	NC	NV	PT	US	RW	BU	PS
Range	0 to 1															
Default	0															
Update rate	Background															

- 0: Trip when threshold reached
- 1: Reduce current limit when threshold reached

The motor is modelled thermally in a way that is equivalent to the electrical circuit shown below:

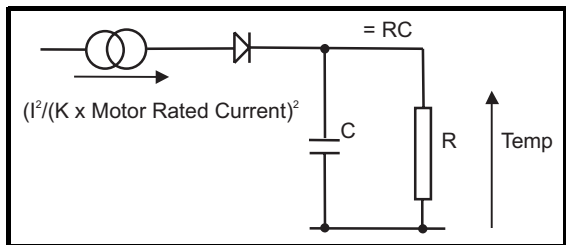

The temperature of the motor as a percentage of maximum temperature, with a constant current magnitude of I , constant value of K and constant value of motor rated current (set by Pr 5.07 or Pr 21.07) after time t is given by

$$\text{Temp} = \left[\frac{I^2}{(K \times \text{Motor rated current})^2} \right] (1 - e^{-t/\tau}) \times 100\%$$

This assumes that the maximum allowed motor temperature is produced by $K \times$ Motor rated current and that τ is the thermal time constant of the point in the motor that reaches its maximum allowed temperature first. τ is defined by Pr 4.15. The estimated motor temperature is given by Pr 4.19 as a percentage of maximum temperature. If Pr 4.15 has a value of 0 the thermal time constant is taken as 1.

If the rated current (defined by Pr 5.07 or Pr 21.07 depending on which motor is selected) is less or equal to the Maximum heavy duty rating then Pr 4.25 can be used to select 2 alternative protection characteristics (see diagram below). If Pr 4.25 is 0 the characteristic is for a motor which can operate at rated current over the whole speed range. Induction motors with this type of characteristic normally have forced cooling. If Pr 4.25 is 1 the characteristic is intended for motors where the cooling effect of motor fan reduces with reduced motor speed below half of rated speed. The maximum value for K is 1.05, so that above the knee of the characteristics the motor can operate continuously up to 105% current.

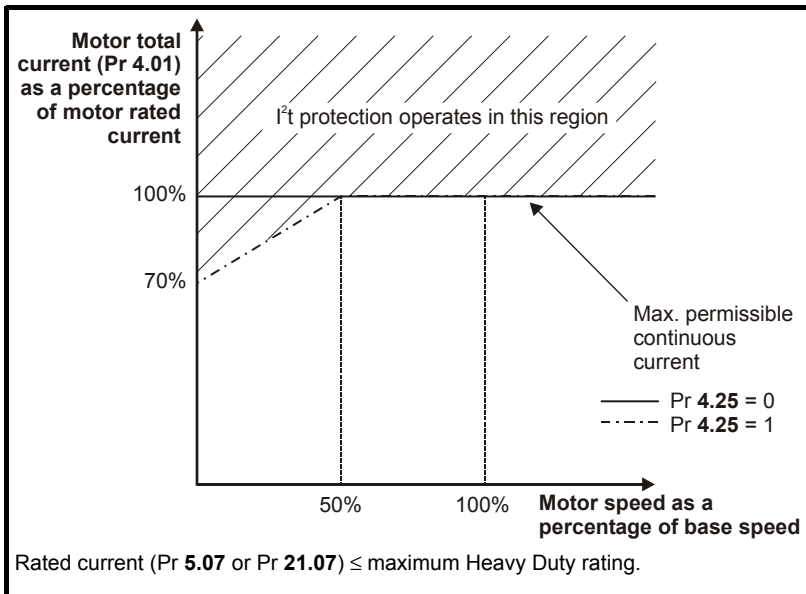

If the rated current is above the maximum Heavy Duty rating then Pr 4.25 can also be used to select 2 alternative protection characteristics. Both characteristics are intended for motors where the cooling effect of the motor fan reduces with reduced motor speed, but with different speeds below which the cooling effect is reduced. The maximum value for K is 1.01, so that above the knee of the characteristics the motor can operate continuously up to 101% current.

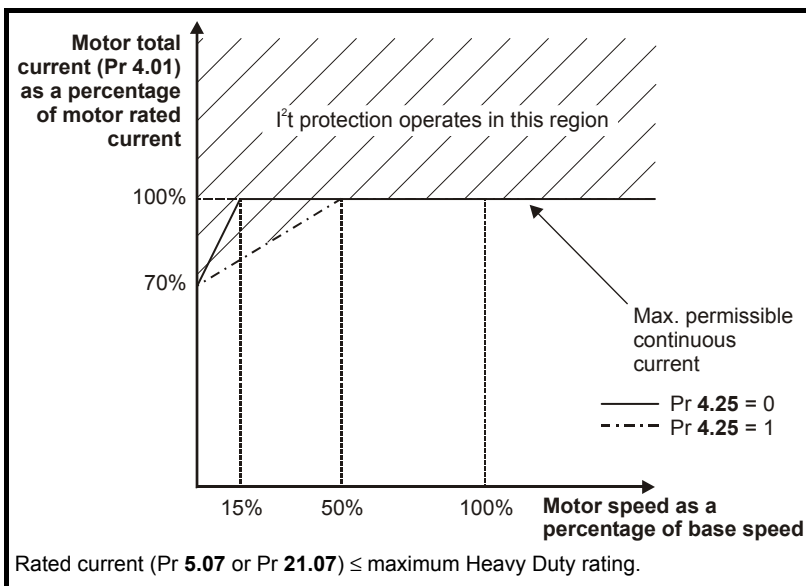

When the estimated temperature reaches 100% the drive takes some action depending on the setting of Pr 4.16. If Pr 4.16 is 0, the drive trips when the threshold is reached. If Pr 4.16 is 1, the current limit is reduced to $(K - 0.05) \times 100\%$ when the temperature is 100%. The current limit is set back to the user defined level when the temperature falls below 95%.

The time for some action to be taken by the drive from cold with constant motor current is given by:

$$T_{trip} = -(\text{Pr } 4.15) \times \ln \left[1 - \left(\frac{K \times \text{Pr } 5.07}{\text{Pr } 4.01} \right)^2 \right]$$

Alternatively the thermal time constant can be calculated from the trip time with a given current from

$$\text{Pr } 4.15 = \frac{-T_{trip}}{\ln \left[1 - \left(\frac{K}{\text{Overload}} \right)^2 \right]}$$

For example, if the drive should trip after supplying 150% overload for 60seconds with K = 1.05 then

$$\text{Pr } 4.15 = \frac{-60}{\ln \left[1 - \left(\frac{1.05}{1.50} \right)^2 \right]} = 89$$

The thermal model temperature accumulator is reset to zero at power-up and accumulates the temperature of the motor whilst the drive remains powered-up. Each time parameter Pr 11.45 is changed to select a new motor, or the rated current defined by Pr 5.07 or Pr 21.07 (depending on the motor selected) is altered, the accumulator is reset to zero.

4.17	Reactive current (motor magnetising current)															
Coding	Bit	SP	FI	DE	Txt	VM	DP	ND	RA	NC	NV	PT	US	RW	BU	PS
			1			1	2	1		1		1				
Range	±DRIVE_CURRENT_MAX A															
Update rate	Background															

This parameter is proportional to the length of the vector in the x axis of the reference frame and is equivalent to the reactive current (magnetising current) in each output phase in amps.

4.18	Overriding current limit															
Coding	Bit	SP	FI	DE	Txt	VM	DP	ND	RA	NC	NV	PT	US	RW	BU	PS
						1	1	1		1		1			1	
Range	0 to TORQUE_PROD_CURRENT_MAX %															
Update rate	Background															

This parameter gives an indication of the internal CURRENT_LIMIT_MAX as defined above.

4.19	Overriding accumulator															
Coding	Bit	SP	FI	DE	Txt	VM	DP	ND	RA	NC	NV	PT	US	RW	BU	PS
							1	1		1		1			1	
Range	0.0 to 100.0%															
Update rate	Background															

This parameter gives a continuous indication of modelled motor temperature as a percentage of the trip level.

When this parameter reaches 75% (and the load is above 105%), the drive will flash 'OVLd' on the display to indicate that the motor temperature is excessive and the motor current should be reduced to stop the drive from tripping on 'It'.

When this parameter reaches 100%, the drive will give an 'It' trip or apply a restriction on the current limit (see Pr 4.16 on page 51).

The level of the accumulator is given by:

$$\text{Pr } 4.19 = \left(\frac{\text{Pr } 4.01^2 (1 - e^{-t/\text{Pr } 4.15})}{(\text{Pr } 5.07 \times 1.05)^2} \right) \times 100\%$$

Also see Pr 4.15 on page 51.

4.20	Percentage load															
Coding	Bit	SP	FI	DE	Txt	VM	DP	ND	RA	NC	NV	PT	US	RW	BU	PS
			1			1	1	1		1		1				
Range	±USER_CURRENT_MAX %															
Update rate	Background															

This parameter indicates the drive loading as a percentage of rated active current, where the 100% rated active current is Pr 5.07 x Pr 5.10.

Therefore:

$$\text{Pr } 4.20 = \frac{\text{Motor active current (Pr } 4.02) \times 100\%}{\text{Motor rated current (Pr } 5.07)} \times \text{Power factor (Pr } 5.10)$$

A positive value in this parameter indicates motoring load and a negative value indicates a regenerating load.

4.21	Load display units															
Coding	Bit	SP	FI	DE	Txt	VM	DP	ND	RA	NC	NV	PT	US	RW	BU	PS
					1								1	1	1	
Range	0 to 1															
Update rate	Background															

- 0: Ld Value of Pr 4.20 displayed.
 1: A Value of Pr 4.01 displayed.

This parameter defines whether the load indication in the display status mode displays percentage load or output current

4.22 to 4.23	Unused parameters
---------------------	--------------------------

4.24	User current maximum scaling															
Coding	Bit	SP	FI	DE	Txt	VM	DP	ND	RA	NC	NV	PT	US	RW	BU	PS
						1	1						1	1	1	
Range	0.0 to TORQUE_PROD_CURRENT_MAX %															
Default	165.0															
Update rate	Background															

The maximum for Pr 4.08 and Pr 4.20 is defined by this parameter.

4.25	Low speed thermal protection mode															
Coding	Bit	SP	FI	DE	Txt	VM	DP	ND	RA	NC	NV	PT	US	RW	BU	PS
	1												1	1		
Range	0 or 1															
Default	0															
Update rate	Background															

- 0: Low speed thermal protection mode disabled
 1: Low speed thermal protection mode enabled

See Pr 4.16 on page 51 for details.

4.26	Percentage torque															
Coding	Bit	SP	FI	DE	Txt	VM	DP	ND	RA	NC	NV	PT	US	RW	BU	PS
			1			1	1	1		1		1				
Range	±USER_CURRENT_MAX %															
Update rate	Background															

Pr 4.26 shows the torque producing current (Pr 4.02) as a percentage of the active torque producing current, but with an additional adjustment above base speed so that this parameter shows percentage torque. Below base speed, Pr 4.26 is equal to Pr 4.20. Above base speed the percentage torque producing current (Pr 4.20) is adjusted as follows:

$$\text{Pr 4.26} = \text{Pr 4.20} \times \text{motor rated frequency (Pr 5.06)} / \text{post ramp reference (Pr 2.01)}$$

9.6 Menu 5: Machine control

Table 9-7 Menu 5 parameters: single line descriptions

Parameter	Range	Default	Setting	Update Rate
5.01 Output frequency	± 1500 Hz			21 ms
5.02 Output voltage	0 to AC_VOLTAGE_MAX V			B
5.03 Output power	±POWER_MAX kW			B
5.04 Motor rpm	± 9999 rpm			B
5.05 DC bus voltage	0 to +DC_VOLTAGE_MAX V			B
5.06 Motor rated frequency {39}	0.0 to 1500.0 Hz	50.0(EUR), 60.0(USA)		B
5.07 Motor rated current {06}	0 to RATED_CURRENT_MAX A	Drive rated current {Pr 11.32}		B
5.08 Motor rated full load rpm {07}	0 to 9999 rpm	1500(EUR) 1800(USA)		B
5.09 Motor rated voltage {08}	0 to AC_VOLTAGE_SET_MAX V	200 V drive: 230 400 V drive: 400(EUR) 460(USA)		128 ms
5.10 Motor rated power factor {09}	0.00 to 1.00	0.85		B
5.11 Number of poles {40}	0 to 4	0 (Auto)		B
5.12 Auto-tune {38}	0 to 2	0		B
5.13 Dynamic V to F select {32}	0 or 1	0		B
5.14 Voltage mode select {41}	0 to 5	4		B
5.15 Low frequency voltage boost {42}	0.0 to 50.0% of motor rated voltage	3.0		B
5.16 Not used				
5.17 Stator resistance	0.000 to 65.000 Ω	0.000		B
5.18 Maximum switching frequency {37}	0 to 3	0		B
5.19 High stability space vector modulation	0 or 1	0		B
5.20 Over modulation enable	0 or 1	0		B
5.21 Not used				
5.22 Not used				
5.23 Voltage offset	0.0 to 25.0 V	0.0		B
5.24 Transient inductance (σL_s)	0.000 to 320.00 mH	0.000		B
5.25 Not used				
5.26 Not used				
5.27 Enable slip compensation	0 or 1	1		B
5.28 Not used				
5.29 Not used				
5.30 Not used				
5.31 Not used				
5.32 Not used				
5.33 Not used				
5.34 Speed display units {23}	0 to 2	0		B
5.35 Disable auto-switching frequency change	0 or 1	0		B
5.36 Not used				
5.37 Actual switching frequency	0 to 3			BW
5.38 Not used				
5.39 Not used				
5.40 Not used				
5.41 Not used				
5.42 Not used				
5.43 Not used				
5.44 Not used				
5.45 Not used				
5.46 Not used				
5.47 Not used				
5.48 Not used				
5.49 Not used				
5.50 Security unlock	0 to 999			BR

Figure 9-13 Menu 5 logic diagram

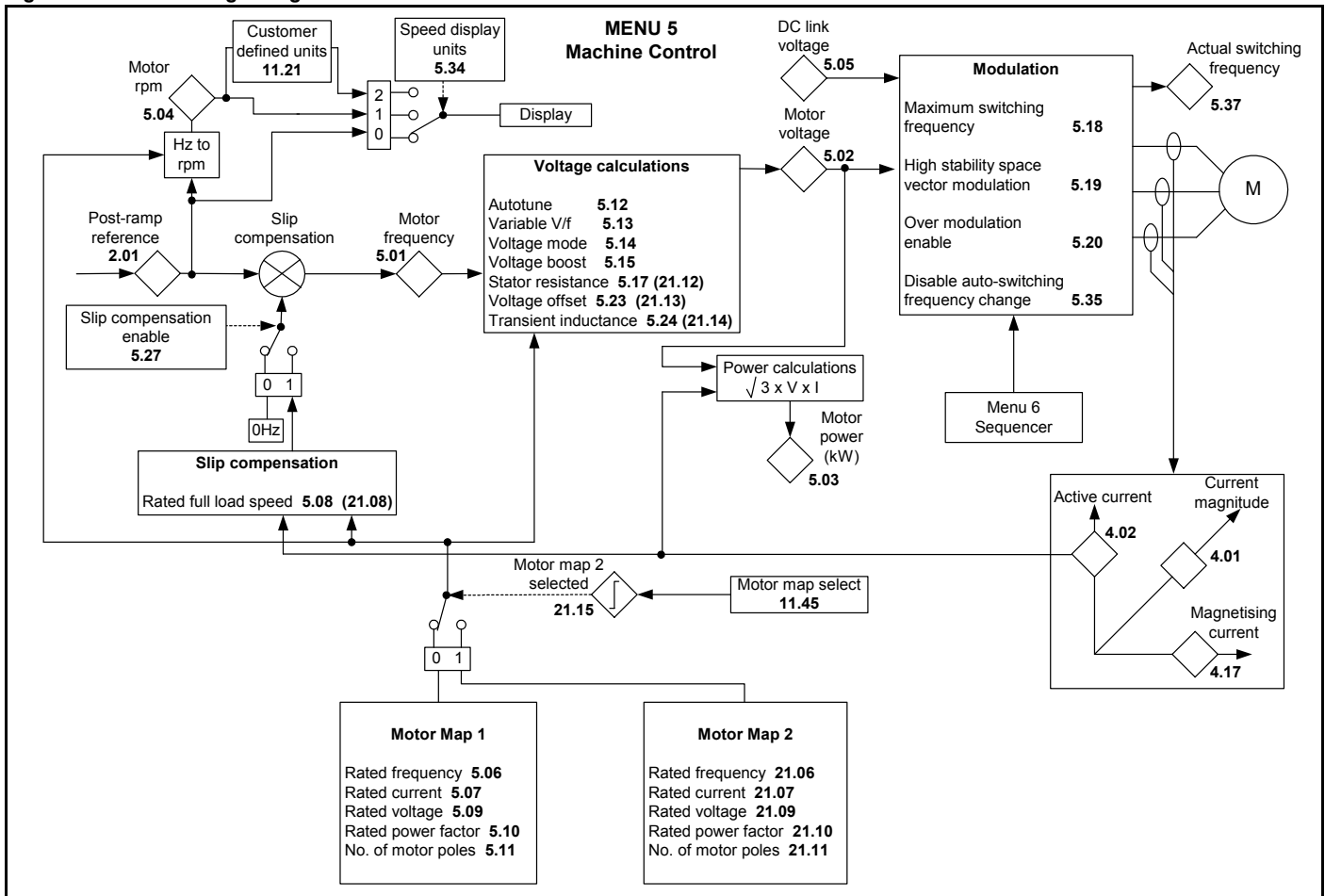

5.01	Output frequency															
Coding	Bit	SP	FI	DE	Txt	VM	DP	ND	RA	NC	NV	PT	US	RW	BU	PS
			1			1	1	1		1		1				
Range	±1500.0 Hz															
Update rate	21 ms															

Although the range for scaling purposes is ±1500Hz, the actual parameter value can be increased beyond this range by slip compensation. This parameter gives the output frequency of the drive, i.e. the sum of the post ramp reference and the slip compensation.

5.02	Output voltage															
Coding	Bit	SP	FI	DE	Txt	VM	DP	ND	RA	NC	NV	PT	US	RW	BU	PS
			1			1		1		1		1			1	
Range	0 to AC_VOLTAGE_MAX V															
Update rate	Background															

This is the modulus of the r.m.s. fundamental line-to-line voltage at the inverter output.

5.03	Output power															
Coding	Bit	SP	FI	DE	Txt	VM	DP	ND	RA	NC	NV	PT	US	RW	BU	PS
			1			1	2	1		1		1				
Range	±POWER_MAX kW															
Update rate	Background															

Total output power of the drive (positive for power flow out of the drive's output terminals). Output power of the drive is calculated from the in phase components of voltage and current such that the total real power output is measured.

$$\text{Output power range} = \frac{\sqrt{3} \times I_{\max} \times \text{Pr 5.09}}{1000}$$

Where:

$$I_{\max} = 150\% \text{ of drive rated current}$$

5.04	Motor rpm															
Coding	Bit	SP	FI	DE	Txt	VM	DP	ND	RA	NC	NV	PT	US	RW	BU	PS
			1					1		1		1				
Range	±9999 rpm															
Update rate	Background															

The motor rpm is calculated from the post ramp reference (Pr 2.01). The speed of rotation is calculated as follows:

$$\text{rpm} = 60 \times \text{Frequency} / \text{No. of pole pairs} = 60 \times \text{Pr 2.01} / (\text{Pr 5.11} / 2)$$

The result will be fairly accurate provided the slip compensation has been set up correctly with the rated full load speed parameter (Pr 5.08). This calculation relies on the number of motor poles being set up correctly in Pr 5.11, or if auto mode is selected (Pr 5.11 = 0) then it relies on a reasonably accurate value of motor rated speed being set in Pr 5.08 to allow correct calculation of the motor poles.

5.05	DC bus voltage															
Coding	Bit	SP	FI	DE	Txt	VM	DP	ND	RA	NC	NV	PT	US	RW	BU	PS
			1			1		1		1		1			1	
Range	0 to +DC_VOLTAGE_MAX V															
Update rate	Background															

Voltage across the internal DC bus of the drive.

5.06	Motor rated frequency															
Coding	Bit	SP	FI	DE	Txt	VM	DP	ND	RA	NC	NV	PT	US	RW	BU	PS
							1						1	1	1	
Range	0.0 to 1500.0 Hz															
Default	EUR: 50.0, USA 60.0															
Second motor parameter	Pr 21.06															
Update rate	Background															

The motor rated frequency and the motor rated voltage (Pr 5.09) are used to define the voltage to frequency characteristic applied to the drive (see Pr 5.09). The motor rated frequency is also used in conjunction with the motor full load rpm to calculate the rated slip for slip compensation (see Pr 5.08).

5.07	Motor rated current															
Coding	Bit	SP	FI	DE	Txt	VM	DP	ND	RA	NC	NV	PT	US	RW	BU	PS
						1	2		1				1	1	1	
Range	0 to RATED_CURRENT_MAX A															
Default	Drive rated current (Pr 11.32)															
Second motor parameter	Pr 21.07															
Update rate	Background															

The motor rated current should be set at the machine nameplate value for rated current.

This value is used in the following:

- Current limit, see Pr 4.07 on page 49
- Motor protection system, see Pr 4.15 on page 51
- Slip compensation, see Pr 5.08
- Vector mode voltage control, see Pr 5.09 on page 59
- Dynamic V to f control, see Pr 5.13 on page 61

5.08	Motor rated full load rpm															
Coding	Bit	SP	FI	DE	Txt	VM	DP	ND	RA	NC	NV	PT	US	RW	BU	PS
													1	1	1	
Range	0 to 9999															
Default	EUR: 1500, USA 1800															
Second motor parameter	Pr 21.08															
Update rate	Background															

The rated full load rpm is used with the motor rated frequency and No. of poles to calculate the rated slip of the induction machine in Hz.

$$\text{Rated slip} = \text{Motor rated frequency} - (\text{No. of motor pole pairs} \times \text{Motor full load rpm} / 60) = \text{Pr 5.06} - [(\text{Pr 5.11} / 2) \times (\text{Pr 5.08} / 60)]$$

The rated slip is used to calculate the frequency adjustment required to compensate for slip from the following equation:

$$\text{Slip compensation} = \text{Rated slip} \times \text{Active current} / \text{Rated active current}$$

If slip compensation is required, Pr 5.27 must be set to a 1 and this parameter should be set to the nameplate value, which should give the correct rpm for a hot machine.

Sometimes it will be necessary to adjust this when the drive is commissioned because the nameplate value may be inaccurate. Slip compensation will operate correctly both below rated speed and within the field weakening region. Slip compensation is normally used to correct for the motor speed to prevent speed variation with load. The rated load rpm can be set higher than synchronous speed to deliberately introduce speed droop. This can be useful to aid load sharing with mechanically coupled motors.

NOTE

If Pr 5.08 is set to 0 or to synchronous speed, slip compensation is disabled.

NOTE

If the full load speed of the motor is above 9999rpm, slip compensation should be disabled. This is because a value above 9999 cannot be entered in Pr 5.08.

5.09 Motor rated voltage																																	
Coding	<table border="1"> <tr> <td>Bit</td> <td>SP</td> <td>FI</td> <td>DE</td> <td>Txt</td> <td>VM</td> <td>DP</td> <td>ND</td> <td>RA</td> <td>NC</td> <td>NV</td> <td>PT</td> <td>US</td> <td>RW</td> <td>BU</td> <td>PS</td> </tr> <tr> <td></td> <td></td> <td></td> <td></td> <td></td> <td>1</td> <td></td> <td></td> <td>1</td> <td></td> <td></td> <td></td> <td>1</td> <td>1</td> <td>1</td> <td></td> </tr> </table>	Bit	SP	FI	DE	Txt	VM	DP	ND	RA	NC	NV	PT	US	RW	BU	PS						1			1				1	1	1	
Bit	SP	FI	DE	Txt	VM	DP	ND	RA	NC	NV	PT	US	RW	BU	PS																		
					1			1				1	1	1																			
Range	0 to AC_VOLTAGE_SET_MAX V																																
Default	200V rating drive: 230V 400V rating drive: EUR: 400V, USA: 460V																																
Second motor parameter	Pr 21.09																																
Update rate	128ms																																

The rated voltage is used in conjunction with the motor rated frequency (Pr 5.06) to define the voltage to frequency characteristic applied to the motor. The following operating methods selected by Pr 5.14 are used to define the drive frequency to voltage characteristic.

Open-loop vector mode: Ur S, Ur A, Ur or Ur I

A linear characteristic is used from 0Hz to rated frequency, and then a constant voltage above rated frequency. When the drive operates between rated frequency/50 and rated frequency/4, full vector based stator resistance (Rs) compensation is applied. However there is a delay of 0.5s when the drive is enabled during which only partial vector based compensation is applied to allow the machine flux to build up. When the drive operates between rated frequency/4 and rated frequency/2 the Rs compensation is gradually reduced to zero as the frequency increases. For the vector modes to operate correctly the stator resistance (Pr 5.17), motor rated power factor (Pr 5.10) and voltage offset (Pr 5.24) are all required to be set-up accurately.

Fixed boost mode: Fd

A linear characteristic is used from 0Hz to rated frequency, and then constant voltage above rated frequency. Low frequency voltage boost as defined by Pr 5.15 is applied as shown below.

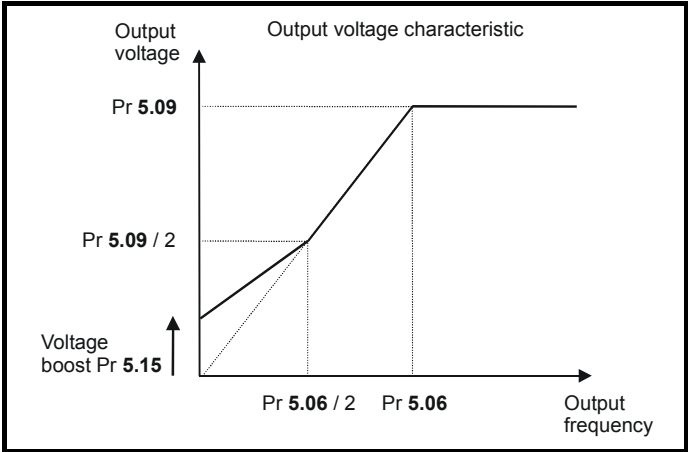

Square law mode: SrE

A square law characteristic is used from 0Hz to rated frequency, and then constant voltage above rated frequency. Low frequency voltage boost raises the start point of the square law characteristic as shown below.

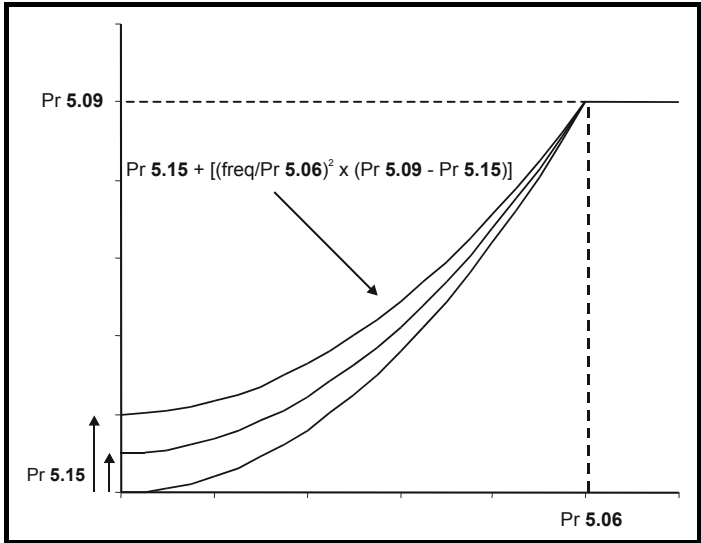

5.10	Motor rated power factor															
Coding	Bit	SP	FI	DE	Txt	VM	DP	ND	RA	NC	NV	PT	US	RW	BU	PS
							2						1	1	1	
Range	0.00 to 1.00															
Default	0.85															
Second motor parameter	Pr 21.10															
Update rate	Background															

The power factor is the true power factor of the motor, i.e. the angle between the motor voltage and current. The power factor is used in conjunction with the motor rated current (Pr 5.07) to calculate the rated active current and magnetising current of the motor. The rated active current is used extensively to control the drive, and the magnetising current is used in vector mode Rs compensation. It is important that this parameter is set up correctly.

5.11	Number of motor poles															
Coding	Bit	SP	FI	DE	Txt	VM	DP	ND	RA	NC	NV	PT	US	RW	BU	PS
					1								1	1	1	
Range	0 (Auto), 1 (2P), 2 (4P), 3 (6P), 4 (8P)															
Default	0 (Auto)															
Second motor parameter	Pr 21.11															
Update rate	Background															

Poles by text (value on display)	Pole pairs (value through serial comms)
Auto	0
2P	1
4P	2
6P	3
8P	4

This parameter is used in the calculation of motor speed and in applying the correct slip compensation. When auto is selected the number of motor poles is automatically calculated from the rated frequency (Pr 5.06) and the rated load rpm (Pr 5.08).

The number of poles = 120 x rated frequency / rpm rounded to the nearest even number.

5.12	Autotune															
Coding	Bit	SP	FI	DE	Txt	VM	DP	ND	RA	NC	NV	PT	US	RW	BU	PS
										1				1	1	
Range	0 to 2															
Default	0															
Update rate	Background															

- 0: No auto-tune
- 1: Non-rotating static auto-tune
- 2: Rotating auto-tune

If this parameter is set to a non-zero value and the drive is enabled and a run command is applied in either direction, the drive will perform an auto-tune test.

The drive must be in disabled or stopped condition before the test is initiated by applying a run command. The autotune test will not begin while the drive is in a disabled or stopped condition.

NOTE

It is important that the drive is at standstill before the auto-tune test is performed if the correct results are to be obtained.

The parameters modified by the autotune tests are defined below. If the second motor map is selected for the duration of the tests (i.e. Pr 11.45 = 1), the second motor parameters in menu 21 are modified and not the parameters described below. All modified parameters are saved to EEPROM immediately after the auto-tune is complete. When the test is completed successfully the drive is disabled. The motor can only be restarted if the enable or run command is removed and then re-applied or if the drive is tripped, reset and then given a run command.

The following parameters are used in the vector control algorithm.

	Parameter	Basic algorithm	Slip compensation
Rated frequency	5.06	✓	✓
Rated current	5.07	✓	✓
Rated load rpm	5.08		✓
Rated voltage	5.09	✓	
Power factor	5.10	✓	
No. of poles	5.11		✓
Stator resistance (R _s)	5.17	✓	
Voltage offset	5.23	✓	
Transient inductance (σL _s)	5.24		

All these parameters can be set by the user except the transient inductance. The autotune test can be used to overwrite the user or default settings as described below. Accurate values of stator resistance and voltage offset are required even for moderate performance in vector mode (an accurate value of power factor is less critical).

1 Stationary test

The stationary test measures the stator resistance (Pr **5.17**) and voltage offset (Pr **5.23**). The power factor (Pr **5.10**) is not affected.

2 Rotating test

A stationary test is performed to measure stator resistance (Pr **5.17**), voltage offset (Pr **5.23**) and transient inductance (Pr **5.24**). The transient inductance is not used directly by the drive, but is an intermediate value in determining the power factor after the rotating test. This is followed by a rotating test in which the motor is accelerated with the currently selected ramps to $\frac{2}{3}$ of rated speed and held at this speed for several seconds. Once the test is complete the power factor (Pr **5.10**) is updated and the motor coasts to a stop.

NOTE

The motor should be unloaded for this test to produce correct results.

The autotune tests may be aborted by removing the run command or if a trip occurs. During the auto-tune tests the following trips can occur in addition to the other drive trips.

Trip code	Reason
tunE	Auto-tune stopped before completion
rS	Stator resistance too high

The rS trip is produced if the drive cannot achieve the necessary current levels to measure the stator resistance during the test (i.e. there is no motor connected to the drive), or if the necessary current level can be achieved, but the calculated resistance exceeds the maximum values for the particular drive size. The maximum measurable value can be calculated from the following formula.

$$R_{s_{max}} = DC_VOLTAGE_MAX / (Drive\ rated\ current \times \sqrt{2} \times 2)$$

NOTE

It is important to make sure that the motor wiring configuration is correct (i.e. Star/Delta) before performing an autotune.

If any changes are made to the drive's motor map parameter, system wiring, motor wiring configuration or motor size or type, the drive must be re-autotuned to the motor. Not performing another auto-tune will result in poor motor performance, OI.AC or It.AC trips.

5.13	Variable torque select															
Coding	Bit	SP	FI	DE	Txt	VM	DP	ND	RA	NC	NV	PT	US	RW	BU	PS
	1												1	1		
Range	0 or 1															
Default	0															
Update rate	Background															

0: Variable torque select disabled

1: Variable torque select enabled

Setting this bit to a 1 enables variable torque mode which is intended for applications where power loss should be kept to a minimum under low load conditions. The V/f ratio is modified with load as follows:

If $|active\ current| < 0.7 \times rated\ active\ current$

$$V/f\ ratio = Normal\ V/f\ ratio \times (0.5 + (active\ current / (2 \times 0.7 \times rated\ active\ current)))$$

Else, if $|active\ current| \geq 0.7 \times rated\ active\ current$

$$V/f\ ratio = Normal\ V/f\ ratio$$

Although the rated frequency varies, the value shown as Pr **5.06** does not vary from that set by the user.

5.14 Voltage mode select	
Coding	Bit SP FI DE Txt VM DP ND RA NC NV PT US RW BU PS
	1
Range	0 (Ur S), 1 (Ur), 2 (Fd), 3 (Ur A), 4 (Ur I), 5 (SrE)
Default	4 (Ur I)
Update rate	Background

0 Ur S Stator resistance and voltage offset measured on each run signal

The stator resistance (Pr 5.17) and the voltage offset (Pr 5.23) are measured and the parameters for the selected motor map are over-written each time the drive is given a run signal. This test can only be done with a stationary machine where the flux has decayed to zero. Therefore this mode should only be used if the machine is guaranteed to be stationary each time the drive is enabled. To prevent the test from being done before the flux has decayed there is a period of 1 second after the drive has been in the ready state during which the test is not done if the drive is re-started. In this case, previously measured values are used. The new values of stator resistance and voltage offset are not automatically saved to EEPROM.

1 Ur No measurements

The stator resistance and voltage offset are not measured. The user can enter the motor and cabling resistance into the stator resistance parameter. However this will not include resistance effects within the drive inverter. Therefore if this mode is to be used, it is best to use the auto-tuning stationary test initially to measure the stator resistance.

2 Fd Fixed boost mode.

Neither the stator resistance nor the voltage offset are used, instead a fixed characteristic with boost applied as defined by Pr 5.15 is used. (see Pr 5.09 on page 59)

NOTE

Fixed boost mode should be used for multiple motor applications.

3 Ur A Stator resistance and voltage offset measured at first drive enable

The stator resistance and voltage offset are measured once, the first time the drive is enabled and run. After the test has been completed successfully the mode is changed to Ur mode. The stator resistance and voltage offset are written to the parameters for the currently selected motor map and these parameters along with this parameter are saved in the EEPROM.

NOTE

If the test fails the stator resistance and voltage offset are not updated, the mode is changed to Ur, but no parameters are saved. If the drive is powered down and back up, the drive will carry out another autotune when the drive is enabled and run.

4 Ur I Stator resistance and voltage offset measured at each power-up and after a drive default

The stator resistance and voltage offset are measured when the drive is first enabled after each power-up and after a drive default. The new values of stator resistance and voltage offset are not automatically saved to EEPROM.

5 SrE Square law characteristic

Neither the stator resistance nor the voltage offset are used, instead a fixed square law characteristic with boost applied as defined by Pr 5.15 is used. (see Pr 5.09 on page 59)

5.15 Low frequency voltage boost	
Coding	Bit SP FI DE Txt VM DP ND RA NC NV PT US RW BU PS
	1
Range	0.0 to 50.0 % of motor rated voltage
Default	3.0
Update rate	Background

The voltage boost level used in fixed boost mode and square law mode is defined by this parameter. See Pr 5.09 on page 59.

5.16 Unused parameter	
-----------------------	--

5.17 Stator resistance	
Coding	Bit SP FI DE Txt VM DP ND RA NC NV PT US RW BU PS
	3 1
Range	0.000 to 65.000 Ω
Default	0.000
Second motor parameter	Pr 21.12
Update rate	Background

This parameter contains the stator resistance of the machine for open loop vector mode operation.

If the drive cannot achieve the necessary current levels to measure the stator resistance during an auto-tune (e.g. there is no motor connected to the drive) an rS trip will occur and the value in Pr 5.17 remains unchanged. If the necessary current levels can be achieved but the calculated resistance exceeds the maximum allowable value for that particular drive size, an rS trip will occur and Pr 5.17 will contain the maximum allowable value.

5.18	Maximum switching frequency															
Coding	Bit	SP	FI	DE	Txt	VM	DP	ND	RA	NC	NV	PT	US	RW	BU	PS
					1				1				1	1	1	
Range	0 (3), 1 (6), 2 (12), 3 (18) kHz															
Default	0 (3)															
Update rate	Background															

- 0: 3kHz
- 1: 6kHz
- 2: 12kHz
- 3: 18kHz

This parameter defines the required switching frequency.

The drive may automatically reduce the actual switching frequency (without changing this parameter) if the power stage becomes too hot. The switching frequency can reduce from 18kHz to 12kHz to 6kHz to 3kHz. An estimation of the IGBT junction temperature is made based on the heatsink temperature and an instantaneous temperature drop using the drive output current and switching frequency. The estimated IGBT junction temperature is displayed in Pr 7.34.

If the temperature exceeds 135°C, the switching frequency is reduced if possible (i.e if the current switching frequency is >3kHz) and auto-switching frequency change mode is enabled (see Pr 5.35 on page 65) to reduce the drives losses and thus reduce the IGBT junction temperature.

If the load condition persists, the junction temperature may continue to rise. If the temperature exceeds 145°C and the switching frequency cannot be reduced the drive will initiate an O.ht1 trip.

Every 20ms the drive will attempt to restore the set switching frequency if the higher switching frequency will not take the IGBT temperature above 135°C.

5.19	High stability space vector modulation															
Coding	Bit	SP	FI	DE	Txt	VM	DP	ND	RA	NC	NV	PT	US	RW	BU	PS
	1												1	1		
Range	0 or 1															
Default	0															
Update rate	Background															

- 0: High stability space vector modulation disabled
- 1: High stability space vector modulation enabled

Normally the drive will use space vector modulation to produce the IGBT control signals. High stability space vector modulation offers three advantages in an open loop drive, but the acoustic noise produced by the motor may increase slightly.

- It is possible for instability to occur around motor rated frequency/2 on light load. The drive uses deadtime compensation to reduce this effect, however, it is still possible that some machines will be unstable. To prevent this, high stability space vector modulation should be enabled by setting this parameter.
- As the output voltage approaches the maximum available from the drive, pulse deletion occurs. This can cause unstable operation with a lightly or fully loaded machine. High stability space vector modulation will reduce this effect.
- High stability space vector modulation will also give a small reduction in drive heat loss.

5.20	Over modulation enable															
Coding	Bit	SP	FI	DE	Txt	VM	DP	ND	RA	NC	NV	PT	US	RW	BU	PS
	1												1	1		
Range	0 or 1															
Default	0															
Update rate	Background															

- 0: Over modulation disabled
- 1: Over modulation enable

The maximum modulation level of the drive is normally limited to unity giving an output voltage equivalent to the drive input voltage minus voltage drops within the drive. If the motor rated voltage is set at the same level as the supply voltage some pulse deletion will occur as the drive output voltage approaches the rated voltage level. If Pr 5.20 is set to 1 the modulator will allow over modulation, so that as the output frequency increases beyond the rated frequency the voltage continues to increase above the rated voltage. The modulation depth will increase beyond unity producing trapezoidal waveforms. This can be used for example to get slightly better performance above rated speed. The disadvantage is that the machine current will be distorted as the modulation depth increases above unity, and will contain a significant amount of low order odd harmonics of the fundamental output frequency.

5.20 to 5.22	Unused parameters
--------------	-------------------

5.23 Voltage offset	
Coding	Bit SP FI DE Txt VM DP ND RA NC NV PT US RW BU PS
Range	0.0 to 25.0 V
Default	0.0
Second motor parameter	Pr 21.13
Update rate	Background

Due to various effects in the drive inverter a voltage offset must be produced before any current flows. To obtain good performance at low frequencies where the machine terminal voltage is small this offset must be taken into account. The value shown in Pr 5.23 is this offset given in line to line rms volts. It is not possible for the user to measure this voltage easily, and so the automatic measurement procedure should be used (see Pr 5.14 on page 62).

5.24 Transient inductance (σL_s)	
Coding	Bit SP FI DE Txt VM DP ND RA NC NV PT US RW BU PS
Range	0.000 to 320.00 mH
Default	0.000
Second motor parameter	Pr 21.14
Update rate	Background

With reference to the diagram below, the transient inductance is defined as

$$\sigma L_s = L_1 + (L_2 \cdot L_m / (L_2 + L_m))$$

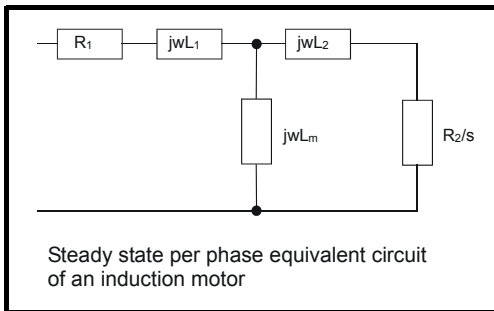

Based on the parameters normally used for the motor equivalent circuit for transient analysis, i.e. $L_s = L_1 + L_m$, $L_r = L_2 + L_m$, the transient inductance is given by:

$$\sigma L_s = L_s - (L_m^2 / L_r)$$

The transient inductance is used as an intermediate variable to calculate the power factor.

5.25 to 5.26	Unused parameters
---------------------	--------------------------

5.27 Enable slip compensation	
Coding	Bit SP FI DE Txt VM DP ND RA NC NV PT US RW BU PS
	1
Range	0 or 1
Default	1
Update rate	Background

0: Slip compensation disabled

1: Slip compensation enabled

The level of slip compensation is set by the rated frequency and rated speed parameters. Slip compensation is only enabled when this parameter is set to 1 and Pr 5.08 is set to a value other than zero or synchronous speed.

5.28 to 5.33	Unused parameters
---------------------	--------------------------

5.34	Speed display units																																
Coding	<table border="1" style="width:100%; border-collapse: collapse;"> <tr> <td>Bit</td><td>SP</td><td>FI</td><td>DE</td><td>Txt</td><td>VM</td><td>DP</td><td>ND</td><td>RA</td><td>NC</td><td>NV</td><td>PT</td><td>US</td><td>RW</td><td>BU</td><td>PS</td> </tr> <tr> <td></td><td></td><td></td><td></td><td>1</td><td></td><td></td><td></td><td></td><td></td><td></td><td></td><td>1</td><td>1</td><td>1</td><td></td> </tr> </table>	Bit	SP	FI	DE	Txt	VM	DP	ND	RA	NC	NV	PT	US	RW	BU	PS					1								1	1	1	
Bit	SP	FI	DE	Txt	VM	DP	ND	RA	NC	NV	PT	US	RW	BU	PS																		
				1								1	1	1																			
Range	0 (Fr), 1 (SP), 2 (Cd)																																
Default	0 (Fr)																																
Update rate	Background																																

Selects the units for the displayed speed.

- 0: Fr Drive output in Hz (Pr 2.01)
- 1: SP Motor speed in RPM (Pr 5.04)
- 2: Cd Machine speed in customer defined units (Scaled from Pr 5.04)

NOTE

See *Parameter scaling* Pr 11.21 on page 115 for information on how to scale the rpm (Pr 5.04) when customer defined units is selected.

5.35	Disable auto-switching frequency change																																
Coding	<table border="1" style="width:100%; border-collapse: collapse;"> <tr> <td>Bit</td><td>SP</td><td>FI</td><td>DE</td><td>Txt</td><td>VM</td><td>DP</td><td>ND</td><td>RA</td><td>NC</td><td>NV</td><td>PT</td><td>US</td><td>RW</td><td>BU</td><td>PS</td> </tr> <tr> <td>1</td><td></td><td></td><td></td><td></td><td></td><td></td><td></td><td></td><td></td><td></td><td></td><td>1</td><td>1</td><td></td><td></td> </tr> </table>	Bit	SP	FI	DE	Txt	VM	DP	ND	RA	NC	NV	PT	US	RW	BU	PS	1												1	1		
Bit	SP	FI	DE	Txt	VM	DP	ND	RA	NC	NV	PT	US	RW	BU	PS																		
1												1	1																				
Range	0 or 1																																
Default	1																																
Update rate	Background																																

- 0: Auto-switching frequency change enabled
- 1: Auto-switching frequency change disabled

The drive thermal protection scheme (see Pr 5.18 on page 63) reduces the switching frequency automatically when necessary to prevent the drive from overheating. It is possible to disable this feature by setting this bit parameter to a 1. If the feature is disabled the drive will trip immediately on O.ht1 when the IGBT temperature gets too high.

5.36	Unused parameter
-------------	-------------------------

5.37	Actual switching frequency																																
Coding	<table border="1" style="width:100%; border-collapse: collapse;"> <tr> <td>Bit</td><td>SP</td><td>FI</td><td>DE</td><td>Txt</td><td>VM</td><td>DP</td><td>ND</td><td>RA</td><td>NC</td><td>NV</td><td>PT</td><td>US</td><td>RW</td><td>BU</td><td>PS</td> </tr> <tr> <td></td><td></td><td></td><td></td><td>1</td><td></td><td></td><td>1</td><td></td><td>1</td><td></td><td>1</td><td></td><td></td><td>1</td><td></td> </tr> </table>	Bit	SP	FI	DE	Txt	VM	DP	ND	RA	NC	NV	PT	US	RW	BU	PS					1			1		1		1			1	
Bit	SP	FI	DE	Txt	VM	DP	ND	RA	NC	NV	PT	US	RW	BU	PS																		
				1			1		1		1			1																			
Range	0 or 3																																
Update rate	Background write																																

Pr 5.37 shows the actual switching frequency used by the inverter. The maximum switching frequency is set with Pr 5.18, but this may be reduced by the drive if automatic switching frequency changes are allowed (Pr 5.35 = 1).

Value	String	Switching frequency (kHz)
0	3	3
1	6	6
2	12	12
3	18	18

5.38 to 5.49	Unused parameters
---------------------	--------------------------

5.50	Security unlock																																
Coding	<table border="1" style="width:100%; border-collapse: collapse;"> <tr> <td>Bit</td><td>SP</td><td>FI</td><td>DE</td><td>Txt</td><td>VM</td><td>DP</td><td>ND</td><td>RA</td><td>NC</td><td>NV</td><td>PT</td><td>US</td><td>RW</td><td>BU</td><td>PS</td> </tr> <tr> <td></td><td></td><td></td><td></td><td></td><td></td><td></td><td>1</td><td></td><td>1</td><td>1</td><td>1</td><td></td><td>1</td><td>1</td><td></td> </tr> </table>	Bit	SP	FI	DE	Txt	VM	DP	ND	RA	NC	NV	PT	US	RW	BU	PS								1		1	1	1		1	1	
Bit	SP	FI	DE	Txt	VM	DP	ND	RA	NC	NV	PT	US	RW	BU	PS																		
							1		1	1	1		1	1																			
Range	0 to 999																																
Update rate	Background read																																

Pr 5.50 is not visible from the keypad and holds the value of the security entered to allow parameters to be edited when security is enabled.

9.7 Menu 6: Drive sequencer and clock

Table 9-8 Menu 6 parameters: single line descriptions

Parameter		Range	Default	Setting	Update Rate
6.01	Stop mode {31}	0 to 4	1		2 ms
6.02	Not used				
6.03	Mains loss mode	0 to 2	0		2 ms
6.04	Start/stop logic select {11}	0 to 6	0 (EUR) 4 (USA)		Drive reset
6.05	Not used				
6.06	Injection braking level	0.0 to 150.0%	100.0		B
6.07	Injection braking time	0.0 to 25.0 s	1.0		2 ms
6.08	Not used				
6.09	Catch a spinning motor {33}	0 to 3	0		B
6.10	Low DC bus operation	0 or 1	0		B
6.11	Remote LED keypad function key status	0 or 1	0		B
6.12	Permanently enable stop key	0 or 1	0		B
6.13	Function key mode	0 to 5	0		BR
6.14	Disable auto reset on enable	0 or 1	0		2 ms
6.15	Drive enable	0 or 1	1		2 ms
6.16	Electricity cost per kWh	0.0 to 600.0 currency/kWh	0.0		B
6.17	Reset energy meter	0 or 1	0		B
6.18	Not used				
6.19	Not used				
6.20	Not used				
6.21	Not used				
6.22	Run time log: years.days	0.000 to 9.365 years.days			B
6.23	Run time log: hours.minutes	0.00 to 23.59 hours.minutes			B
6.24	Energy meter: MWh	0.0 to 999.9 MWh			B
6.25	Energy meter: kWh	0.00 to 99.99 kWh			B
6.26	Running cost	±32000 currency/hour			B
6.27	Not used				
6.28	Not used				
6.29	Permanent hardware enable	0 or 1	1		2 ms
6.30	Sequencing bit: Run forward	0 or 1	0		2 ms
6.31	Sequencing bit: Jog forward	0 or 1	0		2 ms
6.32	Sequencing bit: Run reverse	0 or 1	0		2 ms
6.33	Sequencing bit: Fwd/Rev	0 or 1	0		2 ms
6.34	Sequencing bit: Run	0 or 1	0		2 ms
6.35	Forward limit switch	0 or 1	0		2 ms
6.36	Reverse limit switch	0 or 1	0		2 ms
6.37	Sequencing bit: Jog reverse	0 or 1	0		2 ms
6.38	Not used				
6.39	Sequencing bit: not stop	0 or 1	0		2 ms
6.40	Enable sequencer latching	0 or 1	0		2 ms
6.41	Not used				
6.42	Control word	0 to 32767	0		2 ms
6.43	Control word enable	0 or 1	0		2 ms
6.44	Not used				
6.45	Force cooling fan to run at full speed	0 or 1	0		B

Figure 9-14 Menu 6A logic diagram

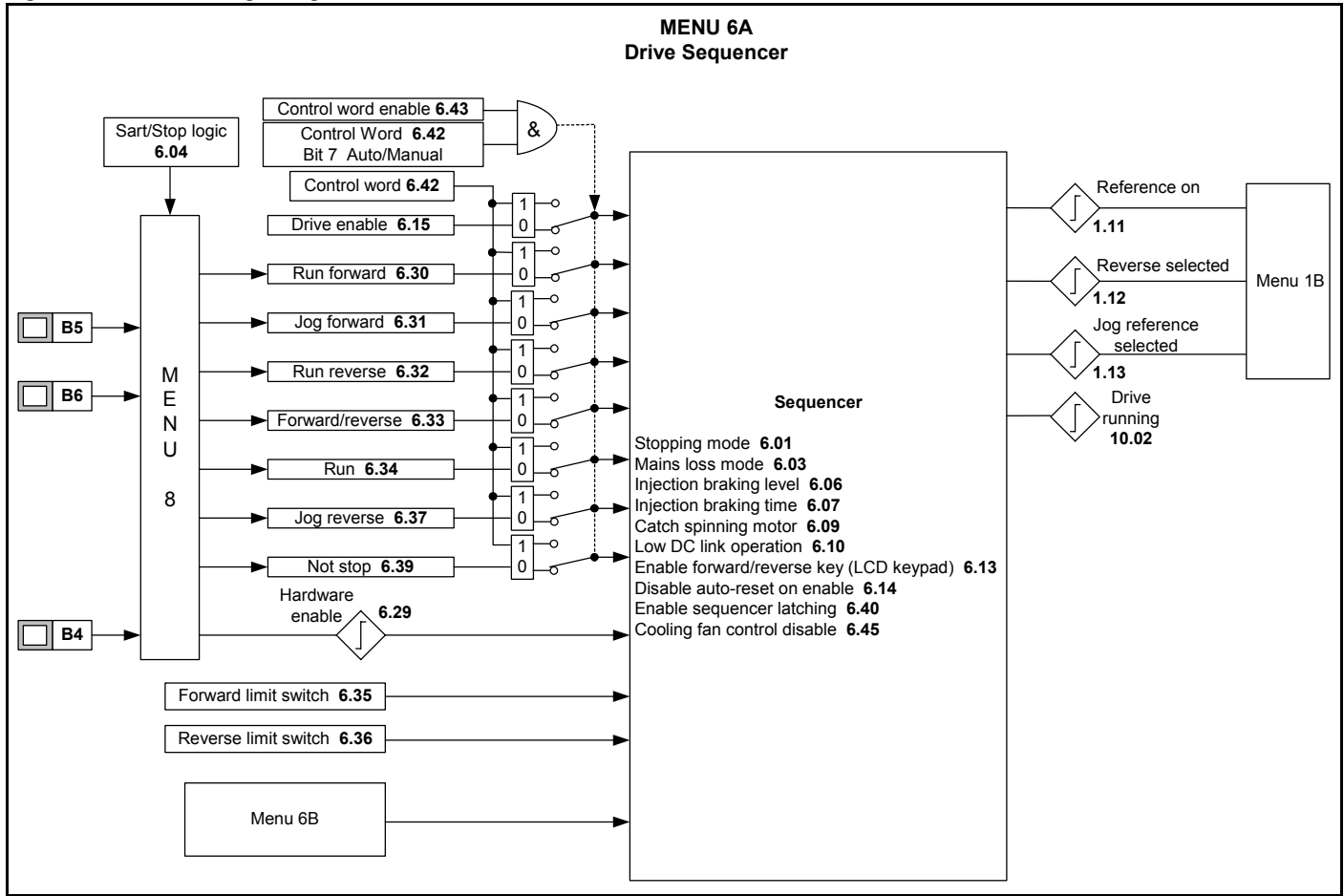
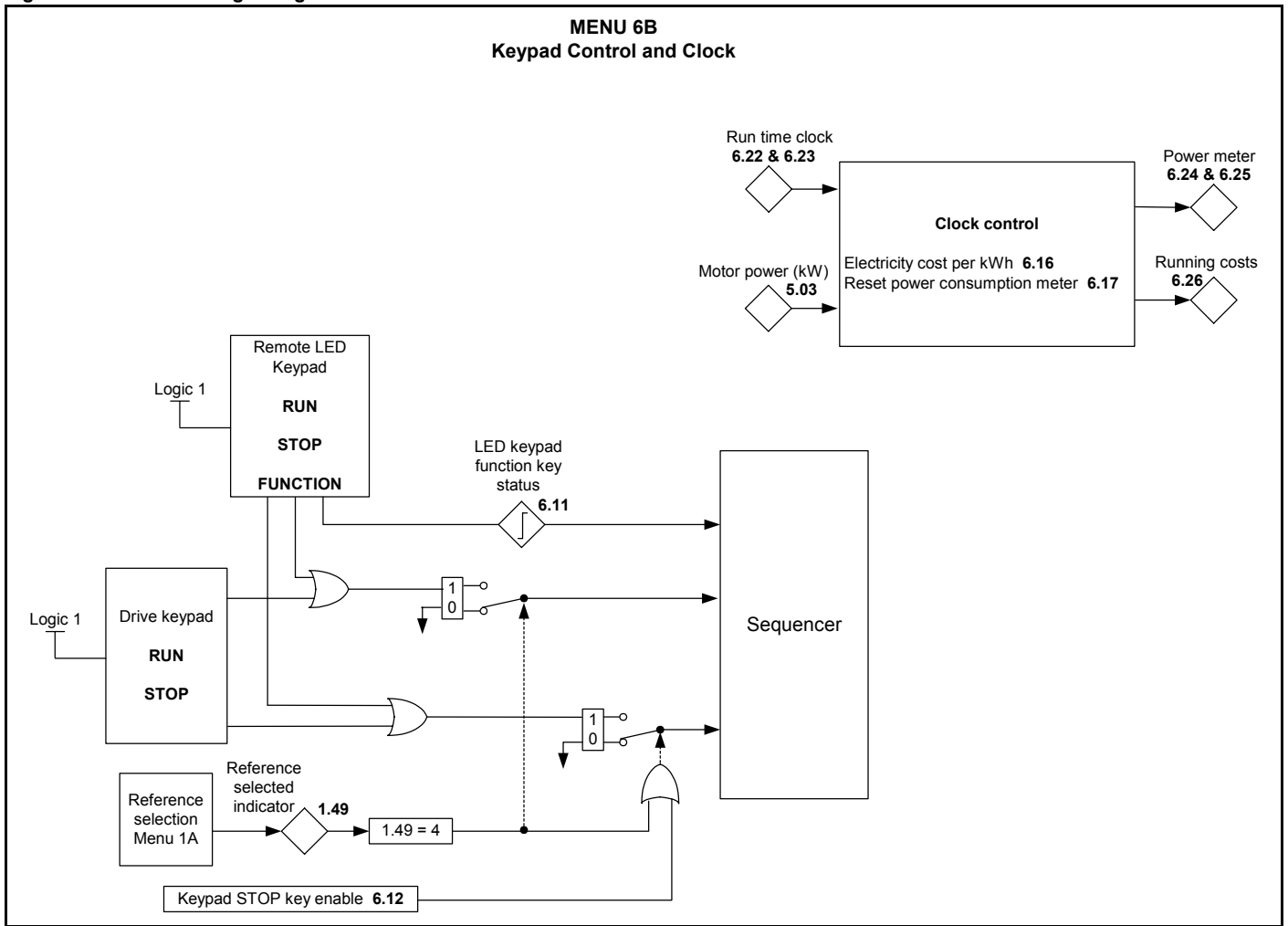

Figure 9-15 Menu 6B logic diagram



6.01	Stop mode															
Coding	Bit	SP	FI	DE	Txt	VM	DP	ND	RA	NC	NV	PT	US	RW	BU	PS
													1	1	1	
Range	0 to 4															
Default	1															
Update rate	2 ms															

- 0: Coast stop
- 1: Ramp stop
- 2: Ramp stop + 1 second dc injection
- 3: Injection braking stop with detection of zero speed
- 4: Timed injection braking stop

Stopping is in two distinct phases: decelerating to stop, and stopped.

Stopping Mode	Phase 1	Phase 2	Comments
0: Coast	Inverter disabled	Drive cannot be re-enabled for a specific time period which is drive size dependant.	Delay in phase 2 allows rotor flux to decay.
1: Ramp	Ramp down to zero frequency	Wait for 1s with inverter enabled	
2: Ramp followed by DC injection	Ramp down to zero frequency	Inject DC at level specified by Pr 6.06 for time defined by Pr 6.07	
3: DC injection with zero speed detection	Low frequency current injection with detection of low speed before next phase	Inject DC at level specified by Pr 6.06 for time defined by Pr 6.07	The drive automatically senses low speed and therefore it adjusts the injection time to suit the application. If the injection current level is too small the drive will not sense low speed (normally a minimum of 50-60% is required).
4: Timed DC injection braking stop	Inject DC at level specified by Pr 6.06 for time specified by Pr 6.07	Inject DC at level specified by Pr 6.06 for 1s	The minimum total injection time is 1s for phase 1 and 1s for phase 2, i.e. 2s in total.

Once modes 3 or 4 have begun the drive must go through the ready state before being restarted either by stopping, tripping or being disabled.

6.02	Unused parameter
------	------------------

6.03	Mains loss mode															
Coding	Bit	SP	FI	DE	Txt	VM	DP	ND	RA	NC	NV	PT	US	RW	BU	PS
					1								1	1	1	
Range	0 to 2															
Default	0															
Update rate	2 ms															

This parameter has 3 settings as follows:

Pr 6.03	Mnemonic	Function
0	diS	Disabled
1	StoP	Stop
2	rd.th	Ride through

0 diS

There is no mains loss detection and the drive operates normally only as long as the DC bus voltage remains within specification (i.e. >Vuu). Once the voltage falls below Vuu a UU trip occurs and this will reset itself if the voltage rises again above VuuRestart in the table below.

1 StoP

The action taken by the drive is the same as for ride through mode, except the ramp down rate is at least as fast as the deceleration ramp setting and the drive will continue to decelerate to 0Hz even if the mains is re-applied.

Depending on whether the mains is re-applied during the ramp down phase will depend on what happens next:

- If the mains is not re-applied during the ramp down phase, the drive will trip on UU after it has reached 0Hz.
- If the mains is re-applied during the ramp down phase, when the drive reaches 0Hz and depending on the state of the control terminals, the drive will either go into the 'rd' ready state or the drive will run back up to set speed.

Normally the controlling system will see that the mains has been lost and even though it has been re-applied, the controller will remove the run terminal so that when it reaches 0Hz, it will go into the 'rd' state.

If normal or timed injection braking is selected, the drive will use ramp mode to stop on loss of the supply. If ramp stop followed by injection braking is selected the drive will ramp to a stop and then attempt to apply DC injection. At this point, unless the mains has been restored the drive is likely to initiate a UU trip.

2 rd.th

The drive detects mains loss when the DC bus voltage falls below V_{ml1} . The drive then enters a mode where a closed-loop controller attempts to hold the DC bus level at V_{ml2} . This causes the motor to decelerate at a rate that increases as the speed falls. If the mains is re-applied it will force the DC bus voltage above the detection threshold V_{ml1} and the drive will continue to operate normally. The output of the mains loss controller is a current demand that is fed into the current control system and therefore the gain parameters Pr 4.13 and Pr 4.14 must be set up for optimum control. See Pr 4.13 and Pr 4.14 on page 50 for set-up details.

The following table shows the voltage levels used by drives with each voltage rating.

Voltage level	200V drive	400V drive
Vuu	175	330
Vml ₁	205	410
Vml ₂	195	390
VuuRestart	215	425

When the drive is carrying out a mains loss stop or ride through, the drive's left hand display will show 'AC'.

6.04	Start/stop logic select															
Coding	Bit	SP	FI	DE	Txt	VM	DP	ND	RA	NC	NV	PT	US	RW	BU	PS
					1								1	1	1	
Range	0 to 6															
Default	EUR: 0, USA: 4															
Update rate	Actioned on exit of edit mode and on drive reset															

This parameter changes the functions of terminals B4, B5 and B6, which are normally associated with the enabling, starting and stopping the drive. This also writes to parameter Pr 6.40 to enable and disable the input latches.

Pr 6.04	Terminal B4	Terminal B5	Terminal B6	Pr 6.40
0	Enable	Run Forward	Run Reverse	0 (non latching)
1	Not Stop	Run Forward	Run Reverse	1 (latching)
2	Enable	Run	Fwd/Rev	0 (non latching)
3	Not Stop	Run	Fwd/Rev	1 (latching)
4	Not Stop	Run	Jog	1 (latching)
5	User programmable	Run Forward	Run Reverse	0 (non latching)
6	User programmable	User programmable	User programmable	User programmable

Pr 6.40, Pr 8.22, Pr 8.23 and Pr 8.24 are also saved when this parameter is modified.

A change to this parameter is only actioned when the drive is stopped, tripped or disabled. If the drive is active when this parameter is changed, the parameter will return to its pre-altered value on exit of edit mode.

In mode 6 the user is free to assign the terminals as appropriate to their application.

6.05	Unused parameter
------	------------------

6.06	Injection braking level															
Coding	Bit	SP	FI	DE	Txt	VM	DP	ND	RA	NC	NV	PT	US	RW	BU	PS
							1		1				1	1	1	
Range	0.0 to 150.0 %															
Default	100.0															
Update rate	Background															

Defines the current level used during DC injection braking as a percentage of rated active current as defined by Pr 5.07.

6.07	Injection braking time															
Coding	Bit	SP	FI	DE	Txt	VM	DP	ND	RA	NC	NV	PT	US	RW	BU	PS
							1						1	1	1	
Range	0.0 to 25.0 s															
Default	1.0															
Update rate	2 ms															

Defines the time of injection braking where this is specified in stopping modes 3 and 4 (see Pr 6.01 on page 69).

6.08	Unused parameter
-------------	-------------------------

6.09	Catch a spinning motor															
Coding	Bit	SP	FI	DE	Txt	VM	DP	ND	RA	NC	NV	PT	US	RW	BU	PS
													1	1	1	
Range	0 to 3															
Default	0															
Update rate	Background															

Pr 6.09	Function
0	Disabled
1	Detect all frequencies
2	Detect positive frequencies only
3	Detect negative frequencies only

When the drive is enabled with this bit at 0, the output frequency starts at zero and ramps to the required reference. When the drive is enabled and this parameter has a non-zero value, the drive performs a start-up test to determine the motor speed and then sets the initial output frequency to the synchronous frequency of the motor. The test is not carried out, and the motor frequency starts at zero, if the run command is given when the drive is in the stop state, or when the drive is first enabled after power up with UR I voltage mode, or when the run command is given in UR S voltage mode.

NOTE

For the test to operate correctly it is important that the stator resistance (Pr 5.17, Pr 21.12) is set up correctly. This applies even if fixed boost (Fd) or square law (SrE) voltage mode is being used. The test uses the rated magnetising current of the motor during the test, therefore the rated current (Pr 5.07, Pr 21.07 and Pr 5.10, Pr 21.10) and power factor should be set to values close to those of the motor, although these parameters are not as critical as the stator resistance.

NOTE

Stationary lightly loaded motors with low inertia may move slightly during the test. The direction of the movement is undefined. Restrictions may be placed on the direction of this movement and on the frequencies detected by the drive as in the above table.

6.10	Low DC bus operation															
Coding	Bit	SP	FI	DE	Txt	VM	DP	ND	RA	NC	NV	PT	US	RW	BU	PS
	1												1	1		
Range	0 or 1															
Default	0															
Update rate	Background															

0: Low DC bus operation disabled

1: Low DC bus operation enabled

On the 400V product setting this bit will enable the drive to run off 240Vac input. The current limit will automatically be reduced therefore only allowing the drive to operate at a lower power rating.

Figure 9-16 Low DC bus operation

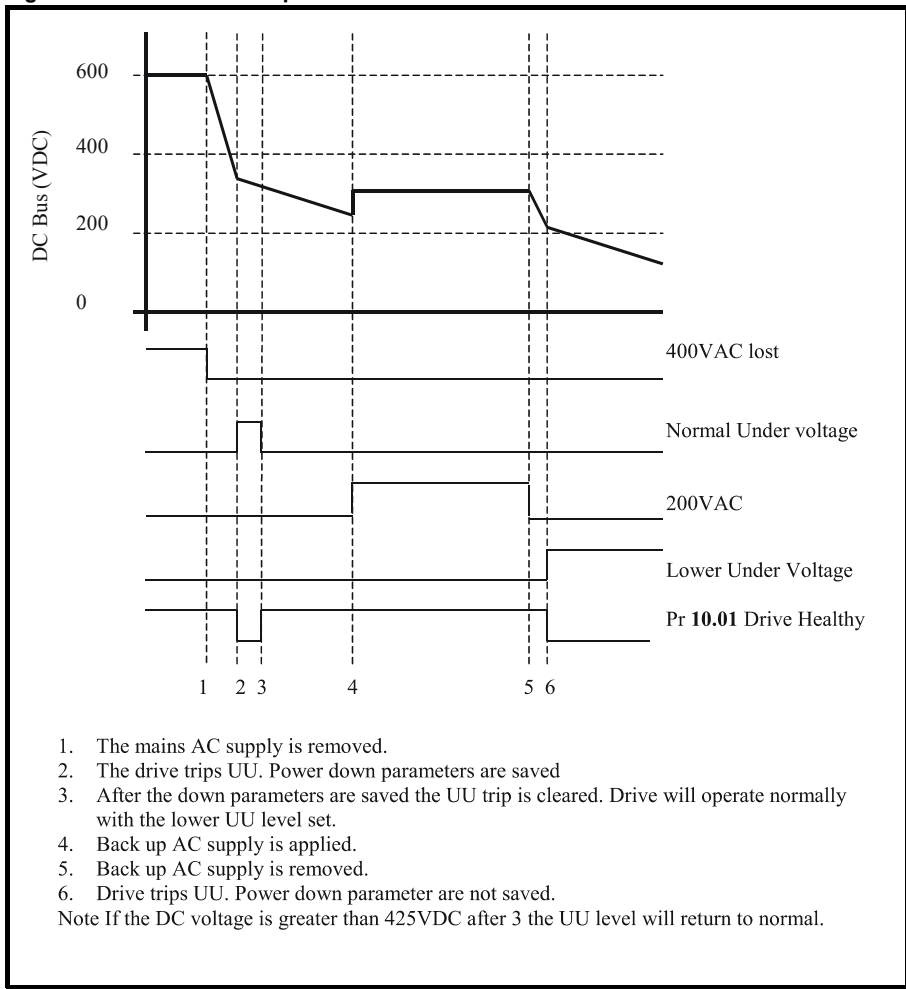

6.11 Remote LED keypad function key status	
Coding	Bit SP FI DE Txt VM DP ND RA NC NV PT US RW BU PS
	1
Range	0 or 1
Default	0
Update rate	Background

The remote LED display has a function key. When the key is pressed this parameter will be 1 otherwise it will be 0. This allows drive user programming to access the function key.

6.12 Permanently enable stop key	
Coding	Bit SP FI DE Txt VM DP ND RA NC NV PT US RW BU PS
	1
Range	0 or 1
Default	0
Update rate	Background

This parameter permanently enables the Stop key on the drive such that the drive will always stop when the stop switch is pressed. If keypad mode is selected this has no effect because the stop key is automatically enabled.

The sequencer logic has been designed so that pressing the stop key, whether the stop key is enabled or not, does not make the drive change from a stopped to a running condition. As the stop key is also used to reset trips this means that if the stop key is pressed when the drive is tripped, the trip will be reset but the drive will not start. This is done as follows.

Sequencer latching not enabled (Pr 6.40 = 0)

If the stop key is pressed when the stop key is enabled (Pr 6.12 = 1) or when the drive is tripped the sequencer run is removed, and so the drive stops or remains stopped respectively. The sequencer run can only then be reapplied after at least one of the following conditions occurs.

1. Run forward, Run reverse and Run sequencing bits all zero
2. OR the drive is disabled via Pr 6.15 or Pr 6.29

3. OR Run forward and Run reverse are both active and have been for 60ms.

The drive can then be restarted by activating the necessary bits to give a normal start. This means that the drive cannot restart automatically after a trip, for example, by pressing the stop key.

Sequencer latching enabled (Pr 6.40 = 1)

If the stop key is pressed when the stop key is enabled (Pr 6.12 = 1) or when the drive is tripped the sequencer run is removed, and so the drive stops or remains stopped respectively. The sequencer run can only then be reapplied after at least one of the following conditions occurs.

1. Run forward, Run reverse and Run sequencing bits all zero after the latches
2. OR Not stop sequencing bit is zero
3. OR the drive is disabled via Pr 6.15 or Pr 6.29
4. OR Run forward and Run reverse are both active and have been for 60ms.

The drive can then be restarted by activating the necessary bits to give a normal start. This means that the drive cannot restart automatically after a trip, for example, by pressing the stop key. Note that Run forward and Run reverse together will reset the stop key condition, but the latches associated with Run forward and Run reverse must then be reset before the drive can be restarted.

6.13	Function key mode															
Coding	Bit	SP	FI	DE	Txt	VM	DP	ND	RA	NC	NV	PT	US	RW	BU	PS
													1	1		
Range	0 to 5															
Default	0															
Update rate	Background read															

On the LCD keypad:

This parameter enables the Fwd/Rev key to operate in keypad mode.

On the LED keypad:

- 0: No Function
- 1: Forward/Reverse toggle
- 2: Run Reverse
- 3: Jog
- 4: Hand off auto
- 5: Function

6.14	Disable auto-reset on enable															
Coding	Bit	SP	FI	DE	Txt	VM	DP	ND	RA	NC	NV	PT	US	RW	BU	PS
	1												1	1		
Range	0 or 1															
Default	0															
Update rate	2 ms															

- 0: Auto reset on enable enabled
- 1: Auto reset on enable disabled

If this parameter is set to 1, the automatic reset on the toggle of the enable terminal of the drive is disabled.

6.15	Drive enable															
Coding	Bit	SP	FI	DE	Txt	VM	DP	ND	RA	NC	NV	PT	US	RW	BU	PS
	1												1	1	1	
Range	0 or 1															
Default	1															
Update rate	2 ms															

- 0: Drive disabled
- 1: Drive enabled

Setting this parameter to 0 will disable the drive. It must be at 1 for the drive to run.

6.16	Electricity cost per kWh															
Coding	Bit	SP	FI	DE	Txt	VM	DP	ND	RA	NC	NV	PT	US	RW	BU	PS
							1						1	1	1	
Range	0.0 to 600.0 Currency/kWh															
Default	0.0															
Update rate	Background															

When this parameter is set up correctly for the local currency, Pr 6.26 will give an instantaneous read out of running cost.

6.17	Reset energy meter															
Coding	Bit	SP	FI	DE	Txt	VM	DP	ND	RA	NC	NV	PT	US	RW	BU	PS
	1									1				1		
Range	0 or 1															
Default	0															
Update rate	Background															

If Pr 6.17 = 1, the energy meter (Pr 6.24 and Pr 6.25) is reset and held at zero.

6.18 to 6.21	Unused parameters
---------------------	--------------------------

6.22	Run time log: years.days															
Coding	Bit	SP	FI	DE	Txt	VM	DP	ND	RA	NC	NV	PT	US	RW	BU	PS
							3	1		1		1			1	1
Range	0.000 to 9.365 years.days															
Update rate	Background															

6.23	Run time log: hours.minutes															
Coding	Bit	SP	FI	DE	Txt	VM	DP	ND	RA	NC	NV	PT	US	RW	BU	PS
							2	1		1		1			1	1
Range	0.00 to 23.59 hours.minutes															
Update rate	Background															

The run time log increments when the drive inverter is active to indicate the amount of time that the drive has been running since leaving the manufacturing plant. In the event of drives never being switched off, the value of this parameter will be updated in EEprom after every 24hours of running.

6.24	Energy meter: MWh															
Coding	Bit	SP	FI	DE	Txt	VM	DP	ND	RA	NC	NV	PT	US	RW	BU	PS
							1	1		1		1				1
Range	0.0 to 999.9 MWh															
Update rate	Background															

6.25	Energy meter: kWh															
Coding	Bit	SP	FI	DE	Txt	VM	DP	ND	RA	NC	NV	PT	US	RW	BU	PS
							2	1		1		1				1
Range	0.00 to 99.99 kWh															
Update rate	Background															

The energy meter indicates the energy supplied from the drive in kWh. Pr 6.24 and Pr 6.25 give an accumulated value of power used. The energy meter is reset and held at zero when Pr 6.17 = 1.

6.26	Running cost															
Coding	Bit	SP	FI	DE	Txt	VM	DP	ND	RA	NC	NV	PT	US	RW	BU	PS
			1					1		1		1				
Range	±3200 currency/hour															
Update rate	Background															

This parameter gives an instantaneous read out of the cost/hour of running the drive. This requires Pr 6.16 to be set up correctly.

6.27 to 6.28	Unused parameters
---------------------	--------------------------

6.29	Permanent hardware enable															
Coding	Bit	SP	FI	DE	Txt	VM	DP	ND	RA	NC	NV	PT	US	RW	BU	PS
	1									1				1	1	
Range	0 or 1															
Default	1															
Update rate	2 ms															

Provides a means of disabling the drive from a programmable input. In order that the drive does not always require a separate enable terminal this parameter is automatically set to a 1 if a terminal is not programmed as an enable terminal. A change from 0 to 1 causes a trip reset (see Pr 6.14 on page 73). In key pad mode and when the drive is being controlled by serial communications this bit is set to 0. When a terminal is set to control this parameter the terminal always has over riding control.

6.30	Sequencing bit: Run forward															
6.31	Sequencing bit: Jog forward															
6.32	Sequencing bit: Run reverse															
6.33	Sequencing bit: Forward/reverse															
6.34	Sequencing bit: Run															
6.35	Forward limit switch															
6.36	Reverse limit switch															
Coding	Bit	SP	FI	DE	Txt	VM	DP	ND	RA	NC	NV	PT	US	RW	BU	PS
	1									1				1		
Range	0 or 1															
Default	0															
Update rate	2 ms															

Digital inputs connected to limit switches should be routed to these parameters if stopping is required at a limit. The drive will respond in 5ms and stop the motor using the currently selected ramp rate. The limit switches are direction dependant so that the motor can rotate in a direction that allows the system to move away from the limit switch.

- Pre-ramp reference > 0Hz Forward limit switch active
- Pre-ramp reference < 0Hz Reverse limit switch active
- Pre-ramp reference = 0Hz Both limit switches active

6.37	Sequencing bit: Jog reverse															
Coding	Bit	SP	FI	DE	Txt	VM	DP	ND	RA	NC	NV	PT	US	RW	BU	PS
	1									1				1		
Range	0 or 1															
Default	0															
Update rate	2 ms															

6.38	Unused parameter															
-------------	-------------------------	--	--	--	--	--	--	--	--	--	--	--	--	--	--	--

6.39	Sequencing bit: Not stop															
Coding	Bit	SP	FI	DE	Txt	VM	DP	ND	RA	NC	NV	PT	US	RW	BU	PS
	1									1				1		
Range	0 or 1															
Default	0															
Update rate	2 ms															

The drive sequencer uses these bits as inputs rather than looking at the terminals directly. This allows the user to define the use of each terminal according to each applications needs.

Although these parameters are R/W, they are volatile and are not stored on power down. Every time the drive powers up they will be reset to 0.

The drive uses these sequencer bits to control the operation of the drive providing the keypad reference has not been selected. If the keypad reference has been selected, all the sequencing bits are disregarded such that only the keypad keys are used to control the drive. In this mode the run and stop keys are always operational.

The drive checks the state of the 'Run Forward' and 'Run Reverse' bits first. If either are set to 1 (but not both) then the drive will run in the commanded direction. If both are found to be 0 then the sequencer looks at the 'Run' bit, and if it is set then the drive is run in the direction commanded by the 'Fwd/Rev' bit (0 = forward, 1 = reverse).

If the 'Jog' bit is set the sequencer switches Pr 1.13 to 1 to select the Jog reference. The sequencer must also see one of the run commands for the drive to run at the jog speed.

Pr 6.04 has a number of pre-determined set-ups that change the functions of the terminals.

Latches are also available for each of the three run inputs, Run Forward, Run Reverse and Run, allowing them to become active from momentary inputs. When enabled, by setting Pr 6.04, a **NOT STOP** input must also be applied by using a digital input to program Pr 6.39. When the **NOT STOP** input becomes inactive each of the three latches are reset. When the latches are disabled, clearing Pr 6.04, they become transparent.

As default, terminals B5 and B6 are configured as Run Forward and Run Reverse. When either Run Forward or Run Reverse is selected, there is a 65ms delay within the drives software before the drive will actually run in the direction indicated. If the drive is running forward, there is also a delay when the Run Forward terminal is opened and the Run Reverse terminal is closed and vice-versa.

This 65ms delay is to allow the drive to change the direction of motor rotation without entering *stopping mode* i.e. if DC injection braking mode was enabled and there was no 65ms delay, when the run forward terminal was opened, the drive would immediately go into the DC injection braking mode rather than ramp down and ramp back up to speed in the reverse direction.

This 65ms delay can cause problems in some applications where a very fast response to the digital inputs is required.

One solution to the above is to set Pr 6.04 to a 2, so that terminal B5 is setup as a run terminal and B6 is setup as a fwd/rev terminal. This configuration eliminates the 65ms delay, and now the only delay is the sample time of the software.

The following diagram shows the main operation of the sequencer in normal and keypad modes. The diagram shows normal control where the sequencer bits are used as inputs and keypad mode where the keypad keys are used as inputs.

In normal operation the sequencer has been designed to operate with Run forward and Run reverse controls, and can be setup to accommodate a Run control and a fwd/rev selector.

Run forward / Run reverse configuration

If a Run forward or Run reverse control is required then bits 6.30 and 6.32 should be used to control the drive (digital inputs should not be routed to bits 6.33 and 6.34).

Run fwd/rev configuration

If Run control with a forward reverse selector is required then bits 6.33 and 6.34 should be used to control the drive (digital inputs should not be routed to bits 6.30 and 6.32).

Using Run forward and reverse, or using Run, can be made latching by setting bit 6.40. The Not stop bit (6.39) should be 1 to allow the sequencing bit to be latched. If the Not stop bit is zero all latches are cleared and held at zero.

Notes on Jog:

To allow the drive to run at the jog speed from standstill the jog input must be made active, while all run inputs remain inactive. If a run command is given while the jog input is active, the drive will at the normal speed reference selected in menu 1. When the run input is active and the drive is running at normal speed reference in menu 1, if the jog input is activated the drive will not act upon the jog reference until the run has been deactivated.

When the drive is required to stop after having been running at the jog speed, the jog (or any other run function) will not be able to go active for approximately 2s, because when the drive is disabled it will coast to a stop and a delay is incurred to allow the rotor flux to decay.

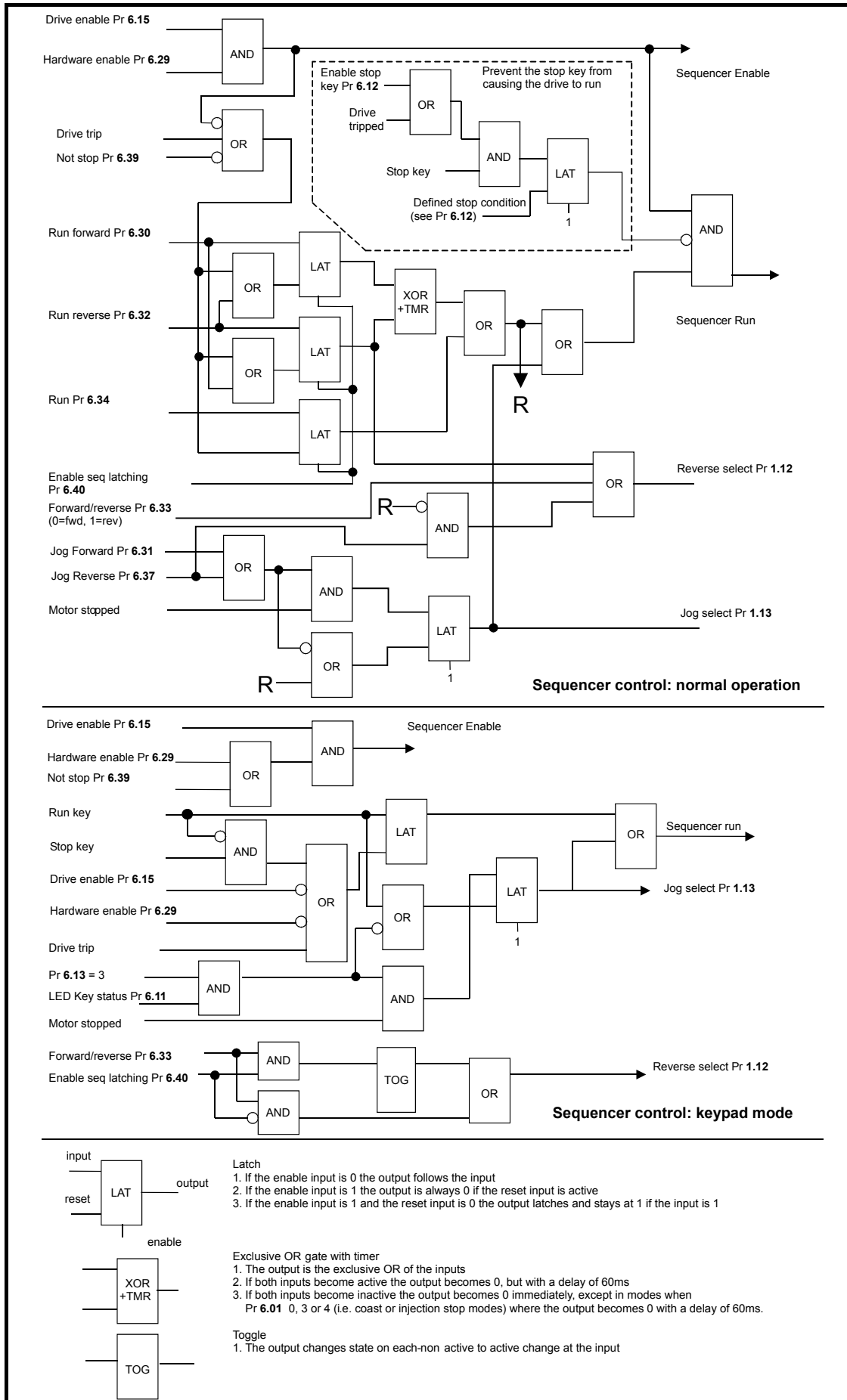

6.40	Enable sequencer latching															
Coding	Bit	SP	FI	DE	Txt	VM	DP	ND	RA	NC	NV	PT	US	RW	BU	PS
	1									1				1		
Range	0 or 1															
Default	0															
Update rate	2 ms															

This bit can be used to enable latches on the run forward, run reverse and run inputs to allow the drive to be controlled from momentary inputs. Also see Pr 6.04 on page 70 and Pr 6.30 to Pr 6.34 on page 75.

6.41	Unused parameter
-------------	-------------------------

6.42	Control word															
Coding	Bit	SP	FI	DE	Txt	VM	DP	ND	RA	NC	NV	PT	US	RW	BU	PS
										1				1	1	
Range	0 to 32767															
Default	0															
Update rate	2 ms															

6.43	Control word enable															
Coding	Bit	SP	FI	DE	Txt	VM	DP	ND	RA	NC	NV	PT	US	RW	BU	PS
	1													1	1	
Range	0 or 1															
Default	0															
Update rate	2 ms															

Pr 6.42 and Pr 6.43 provide a method of controlling the sequencer inputs and other functions directly from a single control word. If Pr 6.43 = 0 the control word has no effect, if Pr 6.43 = 1 the control word is enabled. Each bit of the control word corresponds to a sequencing bit or function as shown below.

Bit	Function	Equivalent parameter
0	Drive enable	Pr 6.15
1	Run forward	Pr 6.30
2	Jog forward	Pr 6.31
3	Run reverse	Pr 6.32
4	Forward/reverse	Pr 6.33
5	Run	Pr 6.34
6	Not stop	Pr 6.39
7	Auto/manual	
8	Analog/Preset reference	Pr 1.42
9	Jog reverse	Pr 6.37
10	Reserved	
11	Reserved	
12	Trip drive	
13	Reset drive	Pr 10.33
14	Keypad watchdog	
15	Reserved	

Bits 0 to 7 & 9: sequencing control

When the control word is enabled (Pr 6.43 = 1), and the Auto/manual bit (bit7) is also set to one, bits 0 to 6 of the control word become active. A hardware enable must also be active (Pr 6.29 = 1). The equivalent parameters are not modified by these bits, but become inactive when the equivalent bits in the control word are active. When the bits are active they replace the functions of the equivalent parameters. For example, if Pr 6.43 = 1 and bit 7 of Pr 6.42 = 1 the drive enable is no longer controlled by Pr 6.15, but by bit 0 of the control word. If either Pr 6.43 = 0, or bit 7 of Pr 6.42 = 0, the drive enable is controlled by Pr 6.15.

Bit 8: Analog/preset reference

When the control word is enabled (Pr 6.43) bit 8 of the control word becomes active. (Bit 7 of the control word has no effect on this function.) The state of bit 8 is written to Pr 1.42. With default drive settings this selects analog reference 1 (bit 8 = 0) or preset reference 1 (bit 8 = 1). If any other drive parameters are routed to Pr 1.42 the value of Pr 1.42 is undefined.

Bit 12: Trip drive

When the control word is enabled (Pr 6.43) bit 12 of the control word becomes active. (Bit 7 of the control word has no effect on this function.) When

bit 12 is set to one a CL.bt trip is initiated. The trip cannot be cleared until the bit is set to zero.

Bit 13: Reset drive

When the control word is enabled (Pr 6.43) bit 13 of the control word becomes active. (Bit 7 of the control word has no effect on this function.) When bit 13 is changed from 0 to 1 the drive is reset. This bit does not modify the equivalent parameter (Pr 10.33).

Bit 14: Keypad watchdog

When the control word is enabled (Pr 6.43) bit 14 of the control word becomes active. (Bit 7 of the control word has no effect on this function.) A watchdog is provided for an external keypad or other device where a break in the communication link must be detected. The watchdog system can be enabled and/or serviced if bit 14 of the control word is changed from zero to one with the control word enabled. Once the watchdog is enabled it must be serviced at least once every second or an "SCL" trip occurs. The watchdog is disabled when an "SCL" trip occurs, and so it must be re-enabled when the trip is reset.

6.44	Unused parameter
-------------	-------------------------

6.45	Force cooling fan to run at full speed															
Coding	Bit	SP	FI	DE	Txt	VM	DP	ND	RA	NC	NV	PT	US	RW	BU	PS
	1												1	1		
Range	0 or 1															
Default	0															
Update rate	Background															

- 0: Fan speed controlled by drive
- 1: Fan runs at full speed

When this parameter is set to 0, the fan is controlled by the drive. If the heatsink temperature is above 60°C or the drive output current (Pr 4.01) is above 75% of the drive rated current, the fan will switch on and run at full speed for a minimum of 10s. After 10s, if the heatsink temperature falls below 60°C or the drive output current falls below 75% of the drive rated current, the fan will switch off. If the temperature remains above 60°C or the drive output current remains above 75% of the drive rated current, the fan will continue running at full speed.

When this parameter is set to 1, the fan runs at full speed at all times when the drive is powered up.

9.8 Menu 7: Analog inputs and outputs

Table 9-9 Menu 7 parameters: single line descriptions

Parameter	Range	Default	Setting	Update Rate
7.01	Analog input 1 monitor (terminal T2)	0.0 to 100.0%		5 ms
7.02	Analog input 2 monitor (terminal T4)	0.0 to 100.0%		5 ms
7.03	Not used			
7.04	Heatsink temperature	-128 to 127 °C		B
7.05	Not used			
7.06	Analog input 1 mode (terminal T2) {16}	0 to 6	4	B
7.07	Not used			
7.08	Analog input 1 scaling	0.000 to 4.000	1.000	B
7.09	Analog input 1 invert	0 or 1	0	5 ms
7.10	Analog input 1 destination	Pr 1.01 to Pr 21.51	Pr 1.36	Drive reset
7.11	Analog input 2 mode (terminal T4)	0 or 1	0	B
7.12	Analog input 2 scaling	0.000 to 4.000	1.000	B
7.13	Analog input 2 invert	0 or 1	0	5 ms
7.14	Analog input 2 destination	Pr 1.01 to Pr 21.51	Pr 1.37	Drive reset
7.15	Not used			
7.16	Not used			
7.17	Not used			
7.18	Not used			
7.19	DAC output source	Pr 0.01 to Pr 21.51	Pr 2.01	Drive reset
7.20	DAC output scaling	0.000 to 4.000	1.000	21 ms
7.21	Not used			
7.22	Not used			
7.23	Not used			
7.24	Not used			
7.25	Not used			
7.26	Not used			
7.27	Not used			
7.28	Current loop loss indicator	0 or 1		5 ms
7.29	Not used			
7.30	Analog input 1 offset	±100.0%		5 ms
7.31	Analog input 2 offset	±100.0%		5 ms
7.32	Not used			
7.33	Analog output control (Terminal B1) {36}	0 to 4	0	Drive reset
7.34	IGBT junction temperature	±200 °C		B
7.35	Drive thermal protection accumulator	0 to 100%		B

Figure 9-17 Menu 7 logic diagram

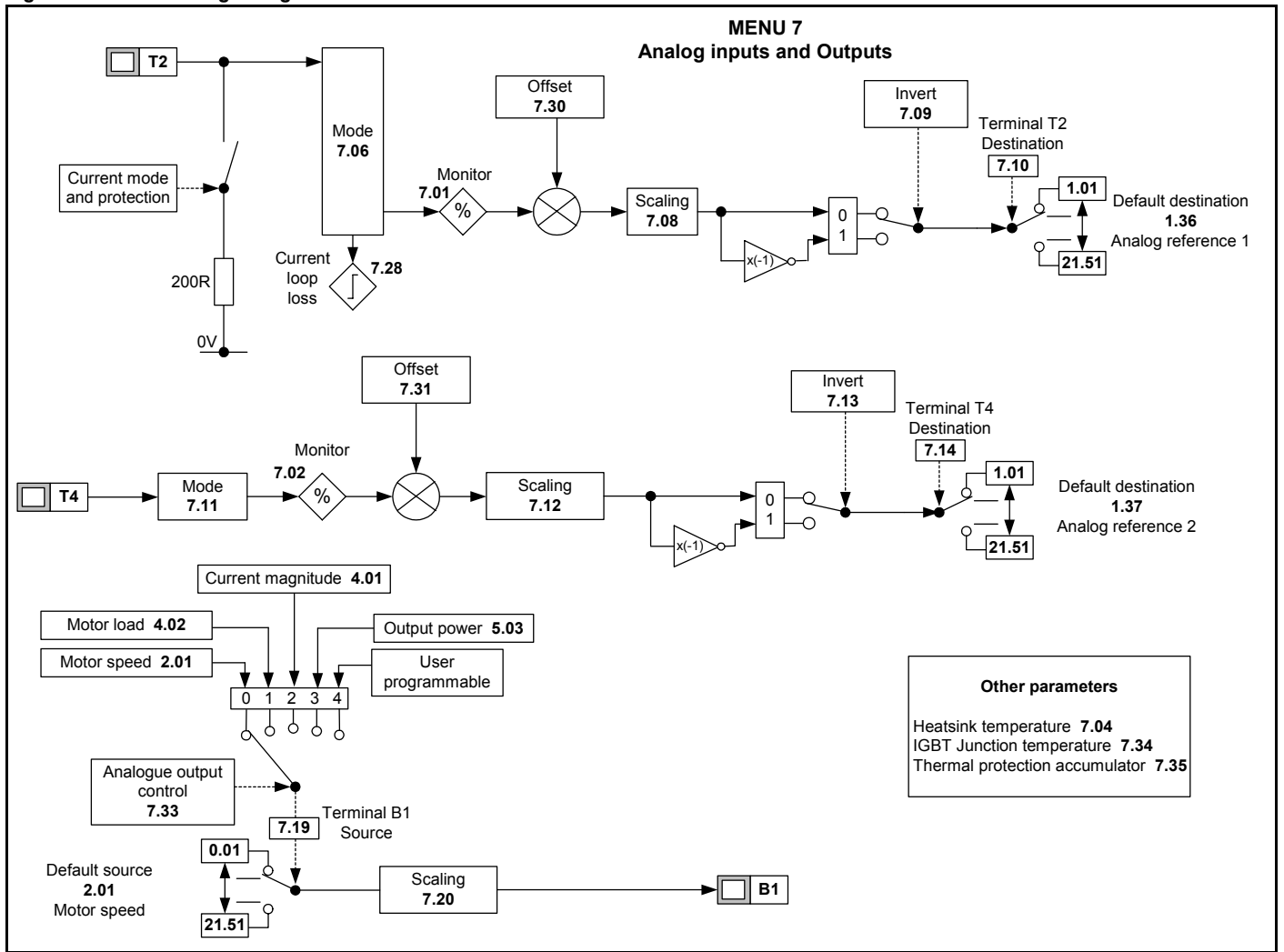

7.01	Analog input 1 monitor (terminal T2)															
Coding	Bit	SP	FI	DE	Txt	VM	DP	ND	RA	NC	NV	PT	US	RW	BU	PS
							1	1		1		1			1	
Range	0.0 to 100.0 %															
Update rate	5 ms															

This parameter displays the level of the analog signal present at analog input 1.

In voltage mode, this is a unipolar voltage input where the input range is 0 to +10V.

In current mode, this is a unipolar current input having a maximum measurable input of 20mA. The drive can be programmed to convert the measured current to any one of the defined ranges in Pr 7.06. The selected range is converted to 0 to 100.0%, the resolution being 10 bit for the 0 - 20mA range.

7.02	Analog input 2 monitor (terminal T4)															
Coding	Bit	SP	FI	DE	Txt	VM	DP	ND	RA	NC	NV	PT	US	RW	BU	PS
							1	1		1		1			1	
Range	0.0 to 100.0 %															
Update rate	5 ms															

This parameter display's the level of the analog input 2.

This is a unipolar voltage input having a range of 0 to +10V which is converted to 0 - 100%, the resolution being 10 bits.

Analog input 2 can also be configured as a digital input in which case this parameter will indicate 0 or 100% depending on the state of the input.

7.03	Unused parameter															
-------------	-------------------------	--	--	--	--	--	--	--	--	--	--	--	--	--	--	--

7.04	Heatsink temperature															
Coding	Bit	SP	FI	DE	Txt	VM	DP	ND	RA	NC	NV	PT	US	RW	BU	PS
								1		1		1				
Range	-128°C to 127°C															
Update rate	Background															

This parameter displays the temperature currently being measured on the heat sink. If the level reaches 95°C the drive will trip O.ht2 on the display. This is used as part of the drive's thermal model, see Pr 10.18 on page 107 for further details.

7.05	Unused parameter															
-------------	-------------------------	--	--	--	--	--	--	--	--	--	--	--	--	--	--	--

7.06	Analog input 1 mode (terminal T2)															
Coding	Bit	SP	FI	DE	Txt	VM	DP	ND	RA	NC	NV	PT	US	RW	BU	PS
													1	1	1	
Range	0 to 6															
Default	4															
Update rate	Background															

Terminal T2 is a voltage/current reference input. The setting of this parameter configures the terminal for the required mode.

Value	Display	Function
0	0-20	0 to 20mA
1	20-0	20 to 0mA
2	4-20	4 to 20mA with trip on loss
3	20-4	20 to 4mA with trip on loss
4	4-.20	4 to 20mA with no trip on loss
5	20-.4	20 to 4mA with no trip on loss
6	VoLt	0 to +10 volts

In modes 2 and 3, a current loop loss trip (cL1) will be generated if the current input falls below 3mA.

NOTE

If 4-20 or 20-4 modes are selected and the drive trips on current loop loss (cL1), analog reference 2 cannot be selected if the current reference is less than 3mA.

If 4-.20 or 20-.4 modes are selected, Pr 7.28 will switch from a 0 to 1 to indicate that the current reference is less than 3mA.

7.07	Unused parameter															
-------------	-------------------------	--	--	--	--	--	--	--	--	--	--	--	--	--	--	--

7.08	Analog input 1 scaling															
Coding	Bit	SP	FI	DE	Txt	VM	DP	ND	RA	NC	NV	PT	US	RW	BU	PS
							3						1	1	1	
Range	0.000 to 4.000															
Default	1.000															
Update rate	Background															

This parameter is used to scale the analog input if so desired. However in most cases it is not necessary as each input is automatically scaled such that for 100.0%, the destination parameters (defined by the settings of Pr 7.10 and Pr 7.14) will be at maximum.

7.09	Analog input 1 invert															
Coding	Bit	SP	FI	DE	Txt	VM	DP	ND	RA	NC	NV	PT	US	RW	BU	PS
	1												1	1		
Range	0 or 1															
Default	0															
Update rate	5 ms															

This parameter can be used to invert the analog input reference (i.e. multiply the input scaling result by -1).

7.10	Analog input 1 destination															
Coding	Bit	SP	FI	DE	Txt	VM	DP	ND	RA	NC	NV	PT	US	RW	BU	PS
				1			2						1	1	1	1
Range	Pr 1.01 to Pr 21.51															
Default	Pr 1.36															
Update rate	Read on drive reset															

As default, this parameter is set-up automatically according to the drive configuration (see Pr 11.27 on page 116).

Only non bit parameters which are not protected can be controlled by analog inputs. If a non valid parameter is programmed to the destination of an analog input, the input is not routed anywhere.

After a modification to this parameter, the destination is only changed when a reset is performed.

7.11	Analog input 2 mode (terminal T4)															
Coding	Bit	SP	FI	DE	Txt	VM	DP	ND	RA	NC	NV	PT	US	RW	BU	PS
					1								1	1	1	
Range	0 to 1															
Default	0															
Update rate	Background															

Analog input 2 can be configured as either a 0 to +10V analog input or a +24V digital input (positive logic).

Value	Display	Function
0	VoLt	0 to +10V
1	dig	0 to +24V

7.12	Analog input 2 scaling															
Coding	Bit	SP	FI	DE	Txt	VM	DP	ND	RA	NC	NV	PT	US	RW	BU	PS
							3						1	1	1	
Range	0.000 to 4.000															
Default	1.000															
Update rate	Background															

When analog input 2 is set up for analog input, this parameter is used to scale the input (see Pr 7.08). When the input is defined as a digital input, this parameter has no effect.

7.13	Analog input 2 invert															
Coding	Bit	SP	FI	DE	Txt	VM	DP	ND	RA	NC	NV	PT	US	RW	BU	PS
	1												1	1		
Range	0 or 1															
Default	0															
Update rate	5 ms															

When set-up as an analog input, this parameter can be used to invert the analog input reference (i.e. multiply the input scaling result by -1).

For digital input, this parameter selects a digital inversion.

7.14	Analog input 2 destination															
Coding	Bit	SP	FI	DE	Txt	VM	DP	ND	RA	NC	NV	PT	US	RW	BU	PS
				1			2					1	1	1	1	
Range	Pr 1.01 to Pr 21.51															
Default	Pr 1.37															
Update rate	Read on drive reset															

As default, this parameter is set-up automatically according to the drive configuration (see Pr 11.27 on page 116).

Only non bit parameters which are not protected can be controlled by analog inputs. If a non valid parameter is programmed to the destination of an analog input, the input is not routed anywhere.

After a modification to this parameter, the destination is only changed when a reset is performed.

7.15 to 7.18	Unused parameters
---------------------	--------------------------

7.19	DAC output source															
Coding	Bit	SP	FI	DE	Txt	VM	DP	ND	RA	NC	NV	PT	US	RW	BU	PS
							2					1	1	1	1	
Range	Pr 0.01 to Pr 21.51															
Default	Pr 2.01															
Update rate	Read on drive reset															

The parameter required to be represented as an analog signal by the analog output on terminal B1, should be programmed in this parameter.

This parameter is used in conjunction with Pr 7.33 to determine the analog output signal. Pr 7.33 has 4 pre-determined settings for easy set-up of the analog output. If the user requires to set Pr 7.19 to another parameter, then Pr 7.33 must be set to 4: **USER**.

See Pr 7.33 for further details. If a non valid parameter is programmed as a source, the output will remain at zero.

NOTE

Users wanting to output load should be aware of the maximum values of the parameters they are routing to the output.

The maximum value of Pr 4.02 (active current) is the maximum level of current that the drive can operate at which is drive rating x 1.5. Therefore, at rated load the analog output will be $1/1.5 \times 10 = 6.66V$.

The maximum value of Pr 4.20 is the active current limit (Pr 4.18) and therefore the analog output will be at 10V when the load is at its maximum.

Users wishing to see 10V output at 100% load will need to set a scale factor in Pr 7.20 equal to Pr 4.18/100 to achieve this.

7.20	DAC output scaling															
Coding	Bit	SP	FI	DE	Txt	VM	DP	ND	RA	NC	NV	PT	US	RW	BU	PS
							3						1	1	1	
Range	0.000 to 4.000															
Default	1.000															
Update rate	21 ms															

This parameters can be used to scale the analog output if so desired. However in most cases it is not necessary as the output is automatically scaled such that when the source parameter is at its maximum, the analog output will be at its maximum.

7.21 to 7.27	Unused parameters
---------------------	--------------------------

7.28	Current loop loss indicator															
Coding	Bit	SP	FI	DE	Txt	VM	DP	ND	RA	NC	NV	PT	US	RW	BU	PS
	1							1		1		1				
Range	0 or 1															
Update rate	5 ms															

If analog input 1 is programmed in any of the modes 2 to 5 (see Pr 7.06 on page 82) then this bit is set if the current input falls below 3mA. This bit can be designated to a digital output to indicate that the current input is less than 3mA.

7.29	Unused parameter															
-------------	-------------------------	--	--	--	--	--	--	--	--	--	--	--	--	--	--	--

7.30	Analog input 1 offset															
7.31	Analog input 2 offset															
Coding	Bit	SP	FI	DE	Txt	VM	DP	ND	RA	NC	NV	PT	US	RW	BU	PS
							1						1	1		
Range	±100.0 %															
Default	0.0															
Update rate	5 ms															

An offset can be added to each analog input with a range from -100% to 100%. If the sum of the input and the offset exceeds ±100% the results is limited to ±100%.

7.32	Unused parameter															
-------------	-------------------------	--	--	--	--	--	--	--	--	--	--	--	--	--	--	--

7.33	Analog output control (Terminal B1)															
Coding	Bit	SP	FI	DE	Txt	VM	DP	ND	RA	NC	NV	PT	US	RW	BU	PS
					1								1	1		
Range	0 to 4															
Default	0															
Update rate	Read on drive reset															

This offers a simple control of Pr 7.19 to change the analog output. Its function is used to set the value of Pr 7.19 between a frequency output, load output, current output, or power output, or to leave the value unchanged. A user wishing to change the analog output to something other than these must first program this parameter to USEr (or 4).

Pr 7.33	Display	Function	Pr 7.19
0	Fr	Frequency output	Pr 2.01
1	Ld	Load output	Pr 4.02
2	A	Current output	Pr 4.01
3	Por	Power output	Pr 5.03
4	USEr	Allows Pr 7.19 to be set up by user.	

0	Fr	Frequency output, Pr 7.19 = Pr 2.01 (<i>Post ramp reference</i>) 0V represents 0Hz/0rpm +10V represents the value of Pr 1.06 (<i>Maximum set speed clamp</i>)
1	Ld	Load output, Pr 7.19 = Pr 4.02 (<i>Active current</i>) $V_{out} = \frac{\text{Active current}}{1.5 \times \text{Drive rated active current}} \times 10$
2	A	0 to 200% output current = 0 to 10V
3	Por	$10V = \frac{\sqrt{3} \times I_{max} \times \text{Pr 5.09}}{1000}$ Where: I_{max} = 150% of drive rated current

7.34		IGBT junction temperature														
Coding	Bit	SP	FI	DE	Txt	VM	DP	ND	RA	NC	NV	PT	US	RW	BU	PS
								1		1		1				
Range	±200 °C															
Update rate	Background															

The IGBT junction temperature is calculated using Heatsink temperature (Pr 7.04) and a thermal model of the drive power stage. The resulting temperature is displayed in this parameter. The calculated IGBT junction temperature is used to modify the drive switching frequency to reduce losses if the devices become too hot (see Pr 5.08 on page 58).

7.35		Drive thermal protection accumulator														
Coding	Bit	SP	FI	DE	Txt	VM	DP	ND	RA	NC	NV	PT	US	RW	BU	PS
								1		1		1			1	
Range	0 to 100 %															
Update rate	Background															

In addition to monitoring the IGBT junction temperatures the drive includes a thermal protection system to protect the other components within the drive. This includes the effects of drive output current and DC bus ripple. The estimated temperature is displayed as a percentage of the trip level in this parameter. If the parameter value reaches 100% an O.ht3 trip is initiated.

9.9 Menu 8: Digital inputs and outputs

Table 9-10 Menu 8 parameters: single line descriptions

Parameter		Range	Default	Setting	Update Rate
8.01	Terminal B3 digital input/output state	0 or 1			2 ms
8.02	Terminal B4 digital input state	0 or 1			2 ms
8.03	Terminal B5 digital input state	0 or 1			2 ms
8.04	Terminal B6 digital input state	0 or 1			2 ms
8.05	Terminal B7 digital input state	0 or 1			2 ms
8.06	Not used				
8.07	Status relay state (Terminals T5 & T6)	0 or 1			2 ms
8.08	Not used				
8.09	Not used				
8.10	Not used				
8.11	Terminal B3 digital input/output invert	0 or 1	0		2 ms
8.12	Terminal B4 digital input invert	0 or 1	0		2 ms
8.13	Terminal B5 digital input invert	0 or 1	0		2 ms
8.14	Terminal B6 digital input invert	0 or 1	0		2 ms
8.15	Terminal B7 digital input invert	0 or 1	1		2 ms
8.16	Not used				
8.17	Status relay invert	0 or 1	0		2 ms
8.18	Not used				
8.19	Not used				
8.20	Digital I/O read word	0 to 95			B
8.21	Terminal B3 digital input destination/output source	Pr 0.01 to 21.51	Pr 10.03		Drive reset
8.22	Terminal B4 digital input destination	Pr 1.01 to 21.51	Pr 6.29		Drive reset
8.23	Terminal B5 digital input destination	Pr 1.01 to 21.51	Pr 6.30		Drive reset
8.24	Terminal B6 digital input destination	Pr 1.01 to 21.51	Pr 6.32		Drive reset
8.25	Terminal B7 digital input destination	Pr 1.01 to 21.51	Pr 1.41		Drive reset
8.26	Not used				
8.27	Status relay source	Pr 0.01 to 21.51	Pr 10.01		Drive reset
8.28	Not used				
8.29	Not used				
8.30	Not used				
8.31	Terminal B3 function select	0 to 3	1		B
8.32	Not used				
8.33	Not used				
8.34	Not used				
8.35	Terminal B7 function select	{34} 0 to 3	0		B
8.36	Not used				
8.37	Not used				
8.38	Not used				
8.39	Not used				
8.40	Not used				
8.41	Digital output control (Terminal B3)	{35} 0 to 8	0		Drive reset

Figure 9-18 Menu 8A logic diagram

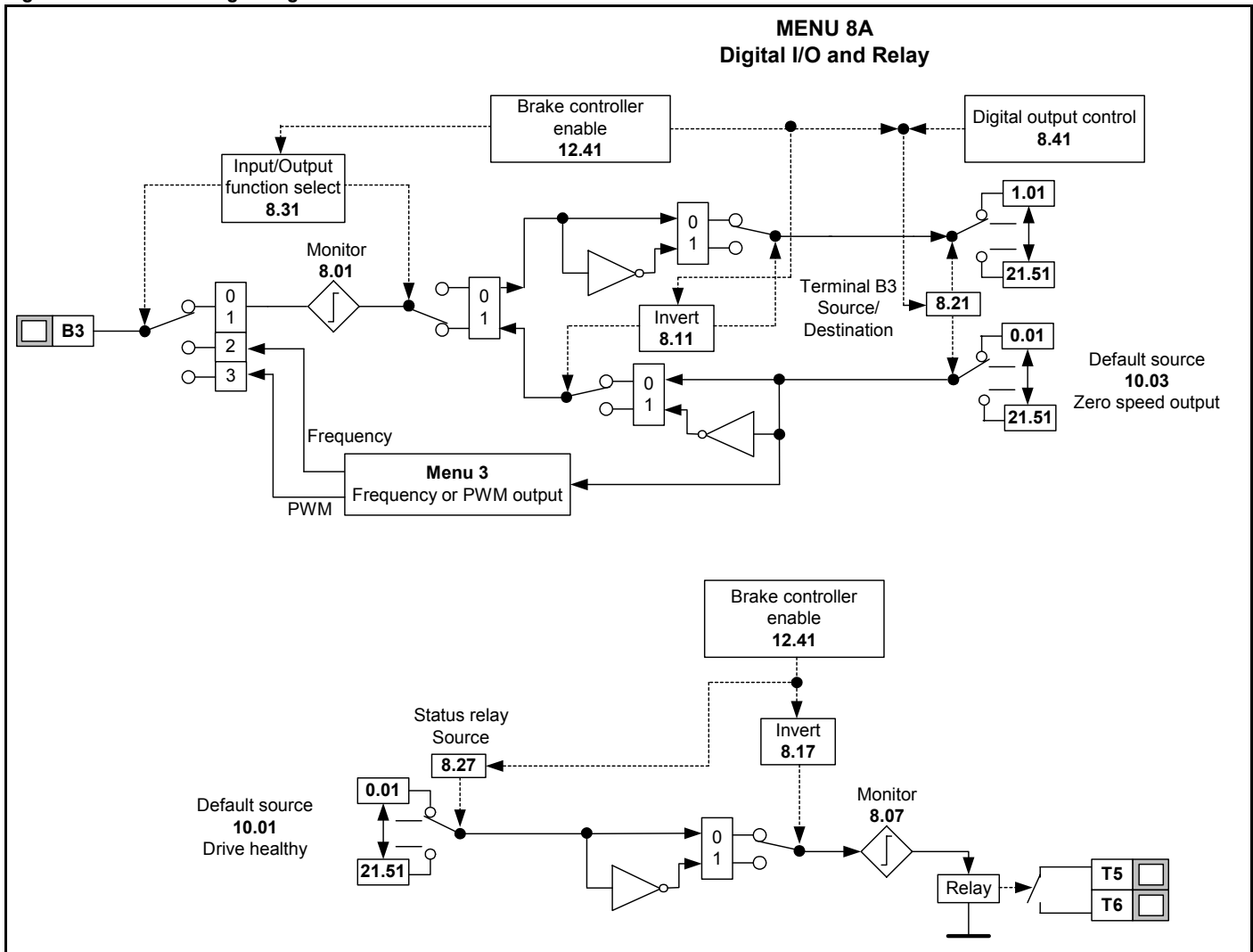

Figure 9-19 Menu 8B logic diagram

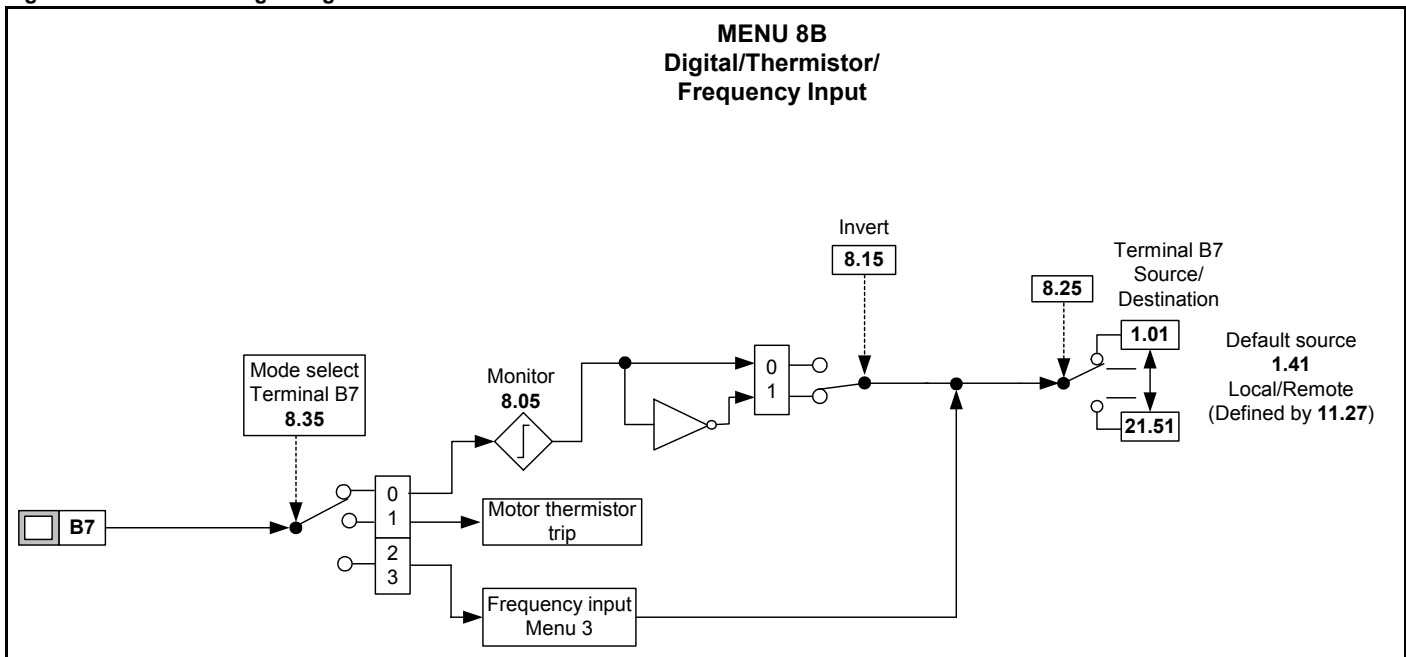

Figure 9-20 Menu 8C logic diagram

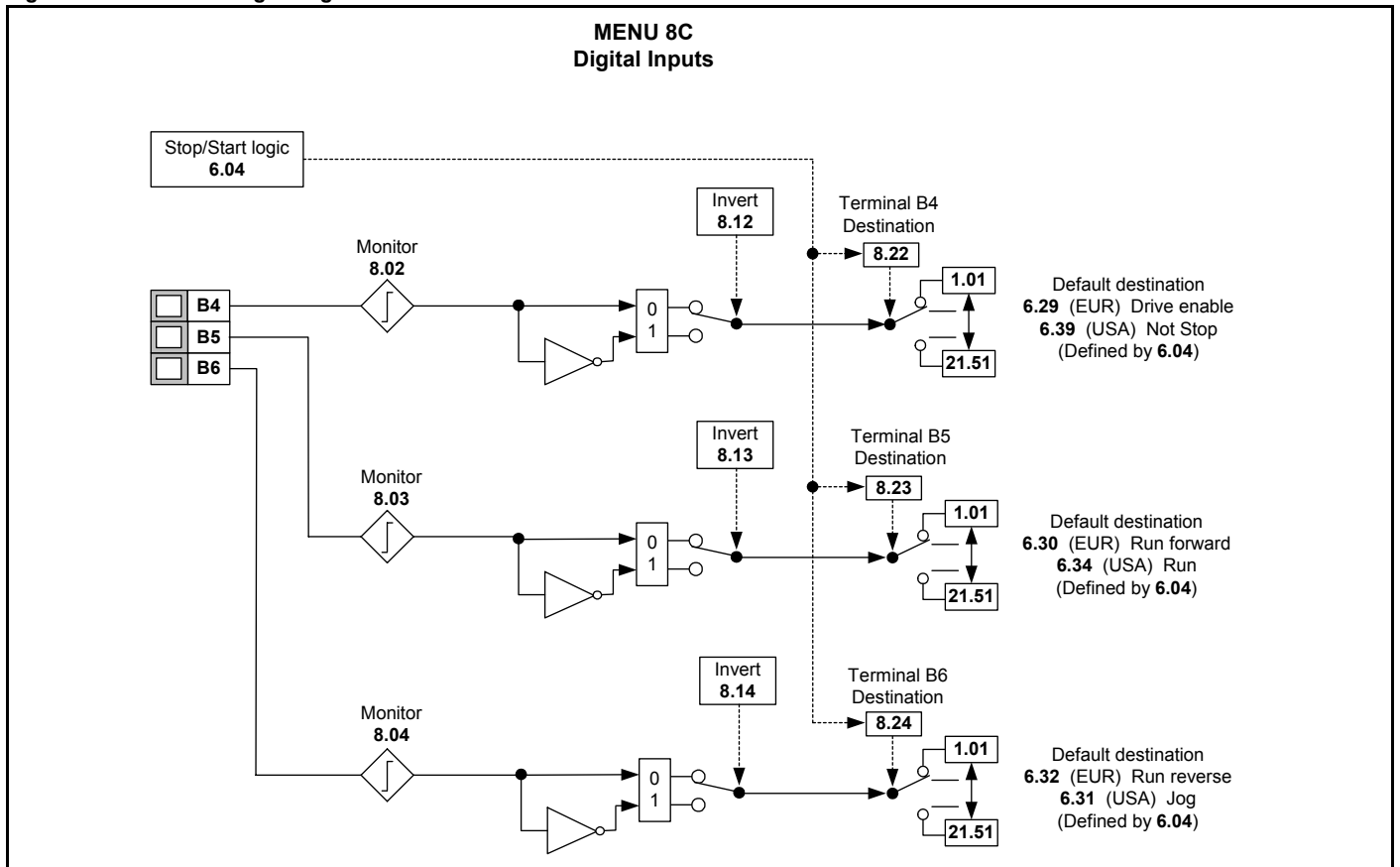
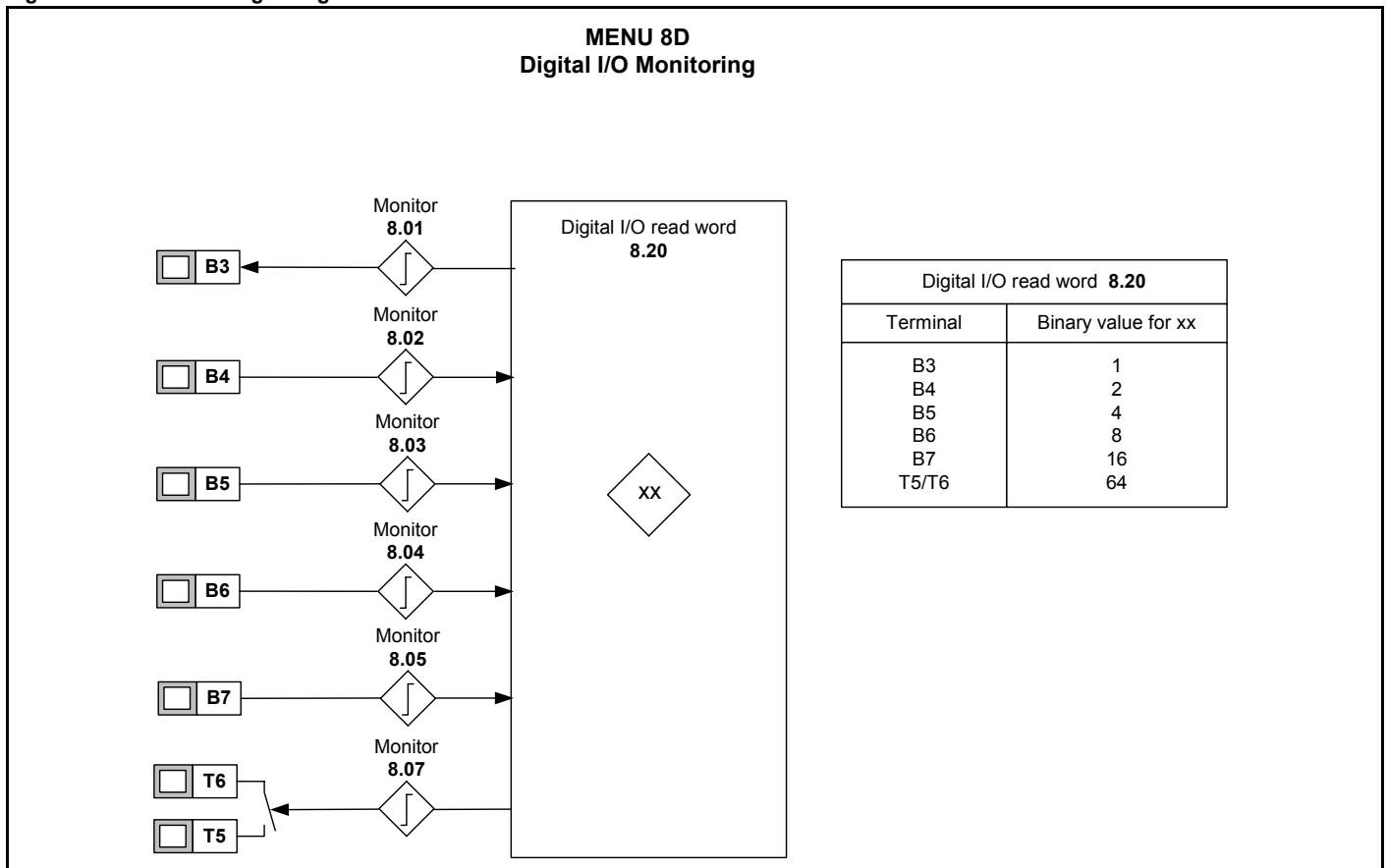

Figure 9-21 Menu 8D logic diagram



Terminals B3 to B7 are five programmable input terminals. In addition terminal B3 can also be programmed as an output terminal, and terminal B7 can be programmed as a motor thermistor input. If an external trip is required then one of the terminals should be programmed to control the External Trip parameter (Pr 10.32) with the invert set to 1 so that the terminal must be made active for the drive not to trip.

NOTE

The digital inputs are set-up in positive logic only. This logic cannot be changed.

8.01	Terminal B3 digital input/output state															
8.02	Terminal B4 digital input state															
8.03	Terminal B5 digital input state															
8.04	Terminal B6 digital input state															
8.05	Terminal B7 digital input state															
Coding	Bit	SP	FI	DE	Txt	VM	DP	ND	RA	NC	NV	PT	US	RW	BU	PS
	1							1		1		1				
Range	0 or 1															
Update rate	2 ms															

- 0: inactive
- 1: active

These parameters indicate the input and output state of the terminals

Terminals B4 to B7 are four programmable digital inputs. Terminal B3 is a digital output that can also be programmed as a digital input, using Pr 8.31. If an external trip is required, then one of the terminals should be programmed to control the external trip parameter (Pr 10.32), with the invert set to a 1 so that the terminal must be made active for the drive not to trip.

The digital inputs are sampled every 1.5ms and the digital output is updated every 21ms.

8.06	Unused parameter
-------------	-------------------------

8.07	Status relay state (Terminals T5 and T6)															
Coding	Bit	SP	FI	DE	Txt	VM	DP	ND	RA	NC	NV	PT	US	RW	BU	PS
	1							1		1		1				
Range	0 or 1															
Update rate	2 ms															

- 0: de-energised
- 1: energised

This parameter indicates the state of the drive's status relay.

8.08 to 8.10	Unused parameters
---------------------	--------------------------

8.11	Terminal B3 digital input/output invert															
8.12	Terminal B4 digital input invert															
8.13	Terminal B5 digital input invert															
8.14	Terminal B6 digital input invert															
Coding	Bit	SP	FI	DE	Txt	VM	DP	ND	RA	NC	NV	PT	US	RW	BU	PS
	1												1	1		
Range	0 or 1															
Default	0															
Update rate	2 ms															

8.15	Terminal B7 digital input invert															
Coding	Bit	SP	FI	DE	Txt	VM	DP	ND	RA	NC	NV	PT	US	RW	BU	PS
	1												1	1	1	
Range	0 or 1															
Default	1															
Update rate	2 ms															

Setting these parameters to a 1 causes the input sense to the destination parameter to be inverted or the output sense from the source to be inverted.

8.16	Unused parameter
-------------	-------------------------

8.17	Status relay invert															
Coding	Bit	SP	FI	DE	Txt	VM	DP	ND	RA	NC	NV	PT	US	RW	BU	PS
	1												1	1		
Range	0 or 1															
Default	0															
Update rate	2 ms															

Setting this parameter to a 1 causes the relay sense to be inverted.

8.18 to 8.19	Unused parameters
---------------------	--------------------------

8.20	Digital I/O read word															
Coding	Bit	SP	FI	DE	Txt	VM	DP	ND	RA	NC	NV	PT	US	RW	BU	PS
								1		1		1			1	
Range	0 to 95															
Update rate	Background															

This word is used to determine the status of the digital I/O by reading one parameter.

Pr 8.20 contains a binary value 'xx'. This binary value is determined by the state of Pr 8.01 to Pr 8.07. So for example, if all terminals were active the value displayed in Pr 8.20 would be the sum of the binary values shown in the table, i.e. 95.

Binary value for xx	Digital I/O
1	Terminal B3
2	Terminal B4
4	Terminal B5
8	Terminal B6
16	Terminal B7
64	Terminal T5/T6

8.21	Terminal B3 digital input destination/output source															
8.22	Terminal B4 digital input destination															
8.23	Terminal B5 digital input destination															
8.24	Terminal B6 digital input destination															
8.25	Terminal B7 digital input destination															
Coding	Bit	SP	FI	DE	Txt	VM	DP	ND	RA	NC	NV	PT	US	RW	BU	PS
			1				2					1	1	1	1	
Range	Destination: Pr 1.01 to Pr 21.51 Source: Pr 0.01 to Pr 21.51															
Update rate	Read on drive reset															

Parameter	Function	Default Setting	Description
8.21	Terminal B3 digital input destination/output source	10.03	Zero Speed (Output)
8.22	Terminal B4 digital input destination	6.29	Enable
8.23	Terminal B5 digital input destination	6.30	Run forward
8.24	Terminal B6 digital input destination	6.32	Run Reverse
8.25	Terminal B7 digital input destination	1.41	Reference select

The terminal configuration is changed using Pr 6.04.

Destination parameters define the parameter each of the programmable inputs is to control. Only bit parameters which are not protected can be controlled by the programmable digital inputs. If a non-valid parameter is programmed, the digital input is not routed anywhere.

Source parameters define the parameter to be represented by the digital output terminal. Only bit parameters can be selected as a source for a digital output. If a non-valid parameter is programmed, then the digital output will remain in the inactive state.

8.26	Unused parameter
-------------	-------------------------

8.27	Status relay source
Coding	Bit SP FI DE Txt VM DP ND RA NC NV PT US RW BU PS
Range	Pr 0.01 to Pr 21.51
Default	Pr 10.01
Update rate	Read on drive reset

This parameter defines the parameter to be represented by the status relay. Only bit parameters can be selected as a source for the relay output. If a non-valid parameter is programmed, then the relay will remain in the de-energised state.

8.28 to 8.30	Unused parameters
---------------------	--------------------------

8.31	Terminal B3 function select
Coding	Bit SP FI DE Txt VM DP ND RA NC NV PT US RW BU PS
Range	0 to 3
Default	1 (out)
Update rate	Background

This parameter selects the function Terminal B3 as follows:

Value	Display	Function
0	in	Digital input
1	out	Digital output
2	Fr	Frequency output
3	PuLS	PWM output (10kHz)

If modes 1, 2 or 3 are selected, the digital input operation of the terminal is disabled.

In modes 0 and 1, terminal B3 will function as digital input/outputs which are described in menu 8.

In modes 2 and 3, terminal B3 will function as a frequency output or a PWM output as described in menu 3.

8.32 to 8.34	Unused parameters
---------------------	--------------------------

8.35	Terminal B7 function select
Coding	Bit SP FI DE Txt VM DP ND RA NC NV PT US RW BU PS
Range	0 to 3
Default	1 (dig)
Update rate	Background

This parameter selects the function of Terminal B7 as follows:

Value	Display	Function
0	dig	Digital input
1	th	Thermistor input
2	Fr	Frequency input
3	Fr.hr	High resolution frequency input

If modes 1, 2 or 3 are selected, the digital input operation of the input is disabled.

In mode 0, the digital input functions as described in menu 8.

In mode 1, the input functions as a motor thermistor.

Trip resistance: 3kΩ

Reset resistance: 1k8

The drive will not trip if the thermistor goes short circuit.

NOTE

The thermistor going short circuit will not damage the drive.

There is no parameter to display the motor temperature.

Connect the motor thermistor between 0V and terminal B7.

Figure 9-22 Connection diagram

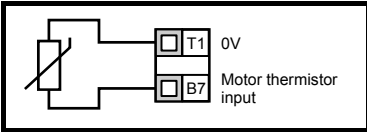

In modes 2 and 3, terminal B7 will function as a frequency input as described in menu 3.

8.36 to 8.40 Unused parameters

8.41	Digital output control (Terminal B3)															
Coding	Bit	SP	FI	DE	Txt	VM	DP	ND	RA	NC	NV	PT	US	RW	BU	PS
					1								1	1	1	
Range	0 to 8															
Default	0 (n=0)															
Update rate	Read on drive reset															

This parameter offers a simple control of Pr 8.21 to change the functionality of the digital output. Its function is used to set the value of Pr 8.21 to one of the parameters listed below.

Value	Display	Function	Parameter Setting
0	n=0	At zero speed	Pr 8.21 = Pr 10.03
1	At.SP	At speed	Pr 8.21 = Pr 10.06
2	Lo.SP	At minimum speed	Pr 8.21 = Pr 10.04
3	hEAL	Drive healthy	Pr 8.21 = Pr 10.01
4	Act	Drive active	Pr 8.21 = Pr 10.02
5	ALAr	General drive alarm	Pr 8.21 = Pr 10.19
6	I.Lt	Current limit active	Pr 8.21 = Pr 10.09
7	At.Ld	At 100% load	Pr 8.21 = Pr 10.08
8	USEr	Allows Pr 8.21 to be set up by user.	

A user wishing to change the digital output to something other than the ones listed above must first program this parameter to 8. Pr 8.21 should then be programmed to the desired bit parameter.

9.10 Menu 9: Programmable logic, motorised pot and binary sum

Table 9-11 Menu 9 parameters: single line descriptions

Parameter		Range	Default	Setting	Update Rate
9.01	Logic function 1 output	0 or 1			21 ms
9.02	Logic function 2 output	0 or 1			21 ms
9.03	Motorised pot output	±100.0%			21 ms
9.04	Logic function 1 source 1	Pr 0.01 to Pr 21.51	Pr 0.00		Drive reset
9.05	Logic function 1 source 1 invert	0 or 1	0		21 ms
9.06	Logic function 1 source 2	Pr 0.01 to Pr 21.51	Pr 0.00		Reset
9.07	Logic function 1 source 2 invert	0 or 1	0		21 ms
9.08	Logic function 1 output invert	0 or 1	0		21 ms
9.09	Logic function 1 delay	±25.0 s	0.0		21 ms
9.10	Logic function 1 destination	Pr 1.01 to Pr 21.51	Pr 0.00		Drive reset
9.11	Not used				
9.12	Not used				
9.13	Not used				
9.14	Logic function 2 source 1	Pr 0.01 to Pr 21.51	Pr 0.00		Drive reset
9.15	Logic function 2 source 1 invert	0 or 1	0		21 ms
9.16	Logic function 2 source 2	Pr 0.01 to Pr 21.51	Pr 0.00		Drive reset
9.17	Logic function 2 source 2 invert	0 or 1	0		21 ms
9.18	Logic function 2 output invert	0 or 1	0		21 ms
9.19	Logic function 2 delay	±25.0 s	0.0		21 ms
9.20	Logic function 2 destination	Pr 1.01 to Pr 21.51	Pr 0.00		Drive reset
9.21	Motorised pot mode	0 to 3	2		BR
9.22	Motorised pot Bipolar select	0 or 1	0		21 ms
9.23	Motorised pot rate	0 to 250 s	20		B
9.24	Motorised pot scale factor	0.000 to 4.000	1.000		B
9.25	Motorised pot destination	Pr 1.01 to Pr 21.51	Pr 0.00		Drive reset
9.26	Motorised pot up	0 or 1			21 ms
9.27	Motorised pot down	0 or 1			21 ms
9.28	Motorised pot reset	0 or 1			21 ms
9.29	Binary sum one's input	0 or 1	0		21 ms
9.30	Binary sum two's input	0 or 1	0		21 ms
9.31	Binary sum four's input	0 or 1	0		21 ms
9.32	Binary sum output	0 to 255			21 ms
9.33	Binary sum destination	Pr 1.01 to Pr 21.51	Pr 0.00		Drive reset
9.34	Binary sum offset	0 to 248	0		21 ms

Figure 9-23 Menu 9A logic diagram

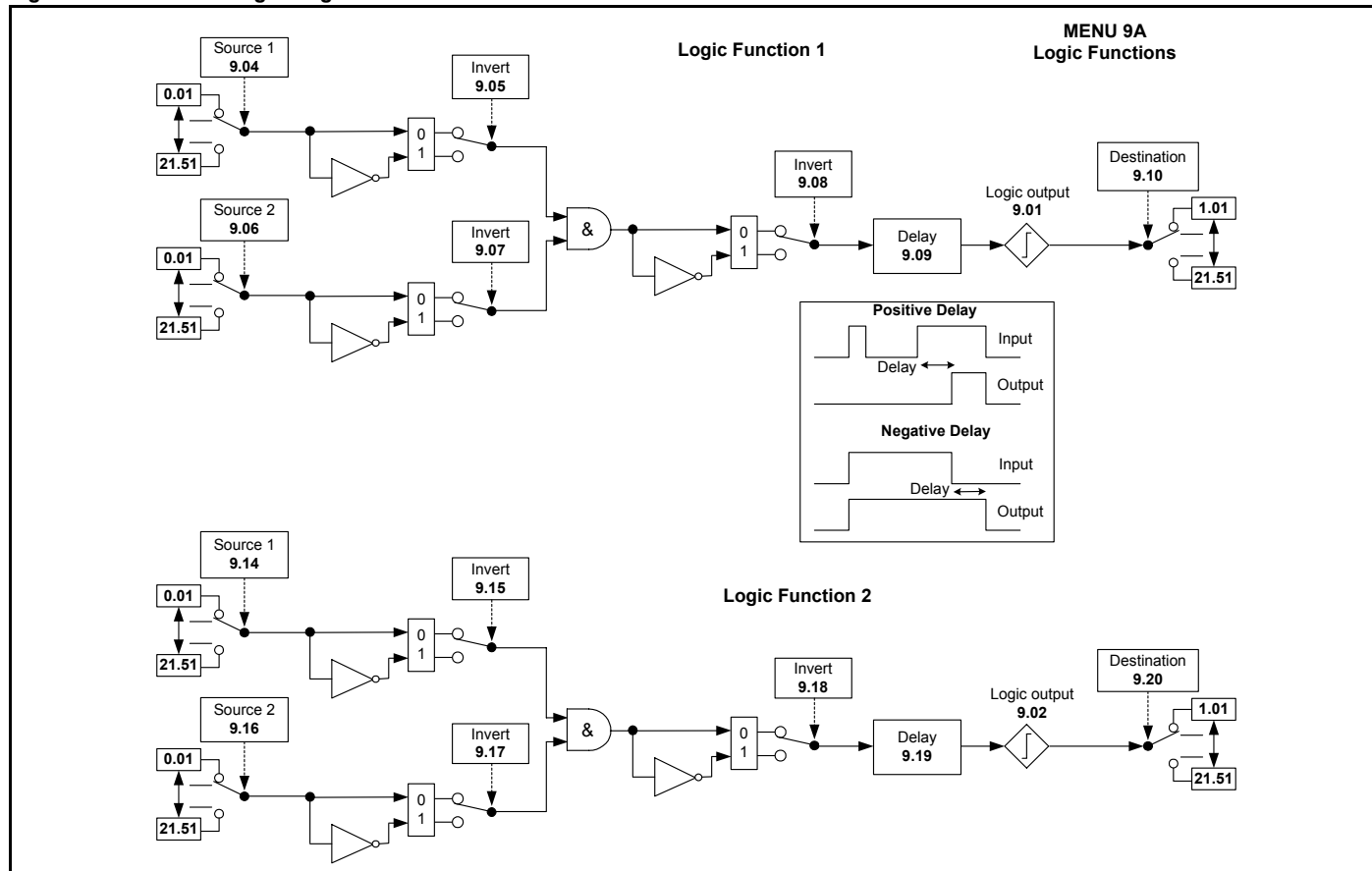
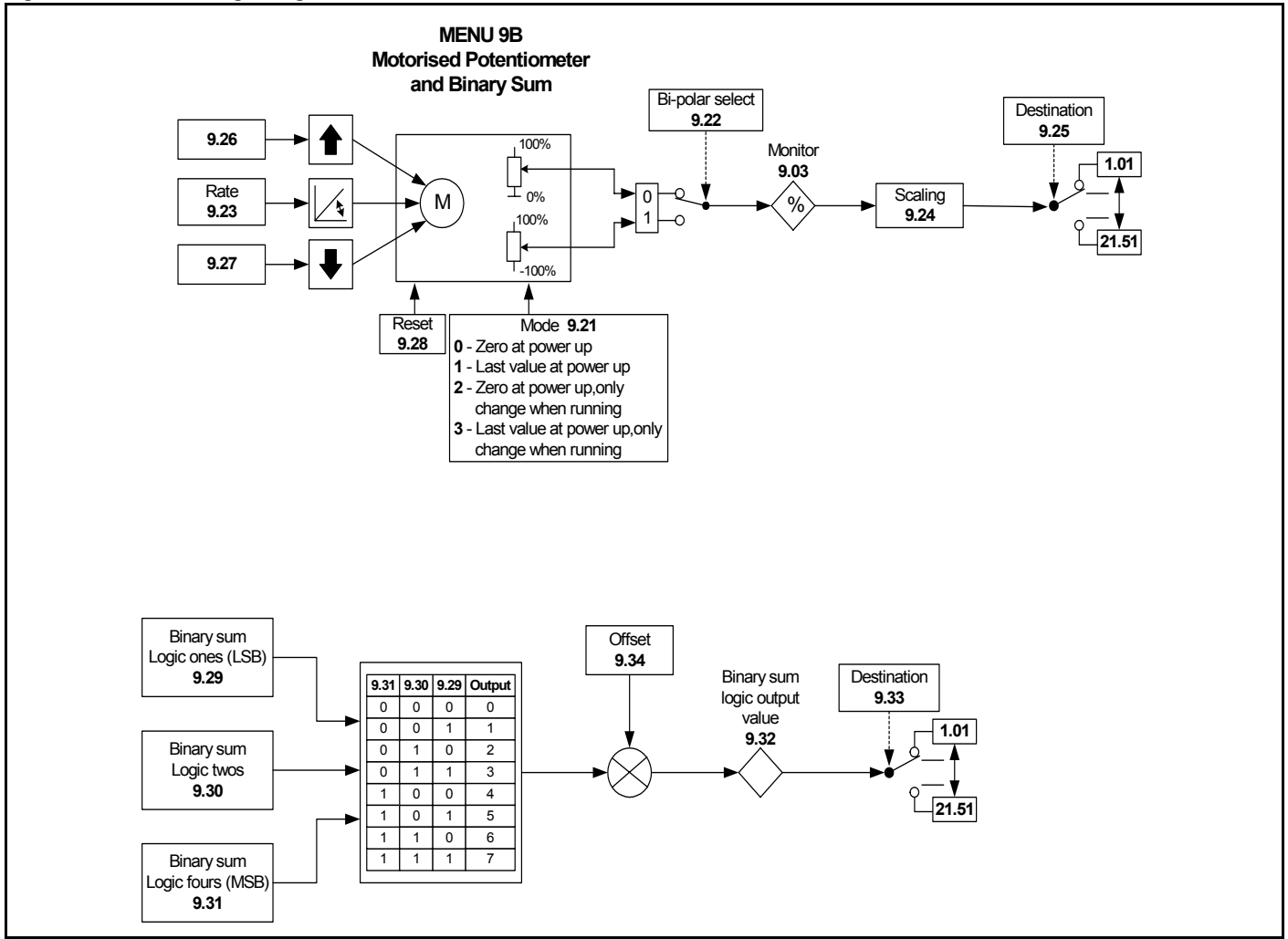

Figure 9-24 Menu 9B logic diagram



Menu 9 contains two programmable logic block functions (which can be used to produce any type of 2 input logic gate, with or without a delay), a motorised potentiometer function and a binary sum block.

The programmable logic functions are active only if both the sources are routed to a valid parameter.

NOTE

The motorised potentiometer or binary sum functions are only active if the output destination is routed to a valid unprotected parameter. If only the indicator parameter is required, the destination parameter should be routed to an unused valid parameter.

9.01	Logic function 1 output indicator															
9.02	Logic function 2 output indicator															
Coding	Bit	SP	FI	DE	Txt	VM	DP	ND	RA	NC	NV	PT	US	RW	BU	PS
	1							1		1		1				
Range	0 or 1															
Update rate	21 ms															

Indicates the output state of the programmable logic function. The output of the logic function can be routed to the digital output if required, by setting the appropriate digital output source in menu 8.

9.03	Motorised pot output															
Coding	Bit	SP	FI	DE	Txt	VM	DP	ND	RA	NC	NV	PT	US	RW	BU	PS
							1	1		1		1				1
Range	±100.0 %															
Update rate	21 ms															

9.04	Logic function 1 source 1															
Coding	Bit	SP	FI	DE	Txt	VM	DP	ND	RA	NC	NV	PT	US	RW	BU	PS
							2					1	1	1	1	
Range	Pr 0.01 to Pr 21.51															
Default	Pr 0.00															
Update rate	Read on drive reset															

This source parameter and Pr 9.14 define the inputs for source 1 of the programmable logic functions.

Only bit parameters can be programmed into these inputs.

If one or both inputs to the logic function are invalid, then the logic output will always be 0.

9.05	Logic function 1 source 1 invert															
Coding	Bit	SP	FI	DE	Txt	VM	DP	ND	RA	NC	NV	PT	US	RW	BU	PS
	1												1	1		
Range	0 or 1															
Default	0															
Update rate	21 ms															

Setting this parameter and Pr 9.15 to a 1 causes the input sense of the logic functions to be inverted.

9.06	Logic function 1 source 2															
Coding	Bit	SP	FI	DE	Txt	VM	DP	ND	RA	NC	NV	PT	US	RW	BU	PS
							2					1	1	1	1	
Range	Pr 0.01 to Pr 21.51															
Default	Pr 0.00															
Update rate	Read on drive reset															

This source parameter and Pr 9.16 defines the inputs for source 2 of the programmable logic functions.

Only bit parameters can be programmed into these inputs.

If one or both inputs to the logic function are invalid, then the logic output will always be 0.

9.07	Logic function 1 source 2 invert															
Coding	Bit	SP	FI	DE	Txt	VM	DP	ND	RA	NC	NV	PT	US	RW	BU	PS
	1												1	1		
Range	0 or 1															
Default	0															
Update rate	21 ms															

Setting this parameter and Pr 9.17 to a 1 causes the input sense of the logic functions to be inverted.

9.08	Logic function 1 output invert															
Coding	Bit	SP	FI	DE	Txt	VM	DP	ND	RA	NC	NV	PT	US	RW	BU	PS
	1												1	1		
Range	0 or 1															
Default	0															
Update rate	21 ms															

Setting this parameter and Pr 9.18 to a 1 causes the output sense from the logic functions to be inverted.

9.09	Logic function 1 delay															
Coding	Bit	SP	FI	DE	Txt	VM	DP	ND	RA	NC	NV	PT	US	RW	BU	PS
							1						1	1		
Range	±25.0 s															
Default	0.0															
Update rate	21 ms															

If the delay parameter is positive, the delay ensures that the output does not become active until an active condition has been present at the input for the delay time as shown below.

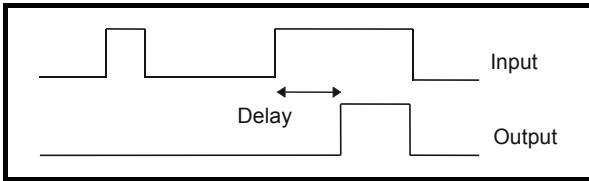

If the delay parameter is negative, the delay holds the output active for the delay period after the active condition has been removed as shown below. Therefore an active input that lasts for as long as the sample time or more will produce an output that lasts at least as long as the delay time.

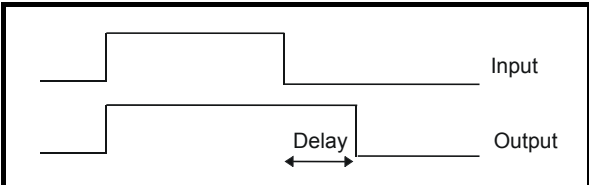

9.10	Logic function 1 destination															
Coding	Bit	SP	FI	DE	Txt	VM	DP	ND	RA	NC	NV	PT	US	RW	BU	PS
							2					1	1	1	1	
Range	Pr 1.01 to Pr 21.51															
Default	Pr 0.00															
Update rate	Read on drive reset															

This destination parameter and Pr 9.20 define the parameters to be controlled by the logic function. Only non-protected bit parameters can be programmed as a destination. If a invalid parameter is programmed, the output is not routed anywhere.

9.11 to 9.13	Unused parameters
---------------------	--------------------------

9.14	Logic function 2 source 1																																
Coding	<table border="1" style="width:100%; border-collapse: collapse;"> <tr> <td>Bit</td><td>SP</td><td>FI</td><td>DE</td><td>Txt</td><td>VM</td><td>DP</td><td>ND</td><td>RA</td><td>NC</td><td>NV</td><td>PT</td><td>US</td><td>RW</td><td>BU</td><td>PS</td> </tr> <tr> <td></td><td></td><td></td><td></td><td></td><td></td><td>2</td><td></td><td></td><td></td><td></td><td>1</td><td>1</td><td>1</td><td>1</td><td></td> </tr> </table>	Bit	SP	FI	DE	Txt	VM	DP	ND	RA	NC	NV	PT	US	RW	BU	PS							2					1	1	1	1	
Bit	SP	FI	DE	Txt	VM	DP	ND	RA	NC	NV	PT	US	RW	BU	PS																		
						2					1	1	1	1																			
Range	Pr 0.01 to Pr 21.51																																
Default	Pr 0.00																																
Update rate	Read on drive reset																																

This source parameter and Pr 9.04 define the inputs for source 1 of the programmable logic functions. Only bit parameters can be programmed into these inputs. If one or both inputs to the logic function are invalid, then the logic output will always be 0.

9.15	Logic function 2 source 1 invert																																
Coding	<table border="1" style="width:100%; border-collapse: collapse;"> <tr> <td>Bit</td><td>SP</td><td>FI</td><td>DE</td><td>Txt</td><td>VM</td><td>DP</td><td>ND</td><td>RA</td><td>NC</td><td>NV</td><td>PT</td><td>US</td><td>RW</td><td>BU</td><td>PS</td> </tr> <tr> <td>1</td><td></td><td></td><td></td><td></td><td></td><td></td><td></td><td></td><td></td><td></td><td></td><td>1</td><td>1</td><td></td><td></td> </tr> </table>	Bit	SP	FI	DE	Txt	VM	DP	ND	RA	NC	NV	PT	US	RW	BU	PS	1												1	1		
Bit	SP	FI	DE	Txt	VM	DP	ND	RA	NC	NV	PT	US	RW	BU	PS																		
1												1	1																				
Range	0 or 1																																
Default	0																																
Update rate	21 ms																																

Setting this parameter and Pr 9.05 to a 1 causes the input sense of the logic functions to be inverted.

9.16	Logic function 2 source 2																																
Coding	<table border="1" style="width:100%; border-collapse: collapse;"> <tr> <td>Bit</td><td>SP</td><td>FI</td><td>DE</td><td>Txt</td><td>VM</td><td>DP</td><td>ND</td><td>RA</td><td>NC</td><td>NV</td><td>PT</td><td>US</td><td>RW</td><td>BU</td><td>PS</td> </tr> <tr> <td></td><td></td><td></td><td></td><td></td><td></td><td>2</td><td></td><td></td><td></td><td></td><td>1</td><td>1</td><td>1</td><td>1</td><td></td> </tr> </table>	Bit	SP	FI	DE	Txt	VM	DP	ND	RA	NC	NV	PT	US	RW	BU	PS							2					1	1	1	1	
Bit	SP	FI	DE	Txt	VM	DP	ND	RA	NC	NV	PT	US	RW	BU	PS																		
						2					1	1	1	1																			
Range	Pr 0.01 to Pr 21.51																																
Default	Pr 0.00																																
Update rate	Read on drive reset																																

This source parameter and Pr 9.06 defines the inputs for source 2 of the programmable logic functions. Only bit parameters can be programmed into these inputs. If one or both inputs to the logic function are invalid, then the logic output will always be 0.

9.17	Logic function 2 source 2 invert																																
Coding	<table border="1" style="width:100%; border-collapse: collapse;"> <tr> <td>Bit</td><td>SP</td><td>FI</td><td>DE</td><td>Txt</td><td>VM</td><td>DP</td><td>ND</td><td>RA</td><td>NC</td><td>NV</td><td>PT</td><td>US</td><td>RW</td><td>BU</td><td>PS</td> </tr> <tr> <td>1</td><td></td><td></td><td></td><td></td><td></td><td></td><td></td><td></td><td></td><td></td><td></td><td>1</td><td>1</td><td></td><td></td> </tr> </table>	Bit	SP	FI	DE	Txt	VM	DP	ND	RA	NC	NV	PT	US	RW	BU	PS	1												1	1		
Bit	SP	FI	DE	Txt	VM	DP	ND	RA	NC	NV	PT	US	RW	BU	PS																		
1												1	1																				
Range	0 or 1																																
Default	0																																
Update rate	21 ms																																

Setting this parameter and Pr 9.07 to a 1 causes the input sense of the logic functions to be inverted.

9.18	Logic function 2 output invert																																
Coding	<table border="1" style="width:100%; border-collapse: collapse;"> <tr> <td>Bit</td><td>SP</td><td>FI</td><td>DE</td><td>Txt</td><td>VM</td><td>DP</td><td>ND</td><td>RA</td><td>NC</td><td>NV</td><td>PT</td><td>US</td><td>RW</td><td>BU</td><td>PS</td> </tr> <tr> <td>1</td><td></td><td></td><td></td><td></td><td></td><td></td><td></td><td></td><td></td><td></td><td></td><td>1</td><td>1</td><td></td><td></td> </tr> </table>	Bit	SP	FI	DE	Txt	VM	DP	ND	RA	NC	NV	PT	US	RW	BU	PS	1												1	1		
Bit	SP	FI	DE	Txt	VM	DP	ND	RA	NC	NV	PT	US	RW	BU	PS																		
1												1	1																				
Range	0 or 1																																
Default	0																																
Update rate	21 ms																																

Setting this parameter and Pr 9.08 to a 1 causes the output sense from the logic functions to be inverted.

9.19	Logic function 2 delay																																
Coding	<table border="1" style="width:100%; border-collapse: collapse;"> <tr> <td>Bit</td><td>SP</td><td>FI</td><td>DE</td><td>Txt</td><td>VM</td><td>DP</td><td>ND</td><td>RA</td><td>NC</td><td>NV</td><td>PT</td><td>US</td><td>RW</td><td>BU</td><td>PS</td> </tr> <tr> <td></td><td></td><td></td><td></td><td></td><td></td><td>1</td><td></td><td></td><td></td><td></td><td></td><td>1</td><td>1</td><td></td><td></td> </tr> </table>	Bit	SP	FI	DE	Txt	VM	DP	ND	RA	NC	NV	PT	US	RW	BU	PS							1						1	1		
Bit	SP	FI	DE	Txt	VM	DP	ND	RA	NC	NV	PT	US	RW	BU	PS																		
						1						1	1																				
Range	±25.0 s																																
Default	0.0																																
Update rate	21 ms																																

If the delay parameter is positive, the delay ensures that the output does not become active until an active condition has been present at the input for

the delay time as shown below.

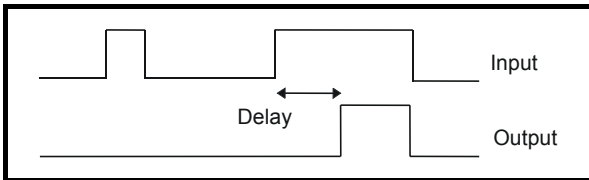

If the delay parameter is negative, the delay holds the output active for the delay period after the active condition has been removed as shown below. Therefore an active input that lasts for as long as the sample time or more will produce an output that lasts at least as long as the delay time.

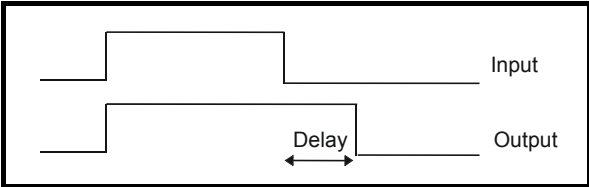

9.20	Logic function 2 destination															
Coding	Bit	SP	FI	DE	Txt	VM	DP	ND	RA	NC	NV	PT	US	RW	BU	PS
							2					1	1	1	1	
Range	Pr 1.01 to Pr 21.51															
Default	Pr 0.00															
Update rate	Read on drive reset															

This destination parameter and Pr 9.10 define the parameters to be controlled by the logic function. Only non-protected bit parameters can be programmed as a destination. If a invalid parameter is programmed, the output is not routed anywhere.

9.21	Motorised pot mode															
Coding	Bit	SP	FI	DE	Txt	VM	DP	ND	RA	NC	NV	PT	US	RW	BU	PS
													1	1	1	
Range	0 to 3															
Default	2															
Update rate	Background read															

The motorised pot modes are given in the table below:

Pr 9.21	Mode	Comments
0	Zero at power-up	Reset to zero at each power-up. Up, down and reset are active at all times.
1	Last value at power-up	Set to value at power-down when drive powered-up. Up, down and reset are active at all times.
2	Zero at power-up and only change when drive running	Reset to zero at each power-up. Up and down are only active when the drive is running (i.e. inverter active). Reset is active at all times.
3	Last value at power-up and only change when drive running	Set to value at power-down when drive powered-up. Up and down are only active when the drive is running (i.e. inverter active). Reset is active at all times.

9.22	Motorised pot bipolar select															
Coding	Bit	SP	FI	DE	Txt	VM	DP	ND	RA	NC	NV	PT	US	RW	BU	PS
	1												1	1		
Range	0 or 1															
Default	0															
Update rate	21 ms															

When this bit is set to 0 the motorised pot output is limited to positive values only (0 to 100.0%). Setting it to 1 allows negative outputs also (-100.0% to 100.0%).

9.23	Motorised pot rate															
Coding	Bit	SP	FI	DE	Txt	VM	DP	ND	RA	NC	NV	PT	US	RW	BU	PS
													1	1	1	
Range	0 to 250 s															
Default	20															
Update rate	Background read															

This parameter defines the time taken for the motorised pot function to ramp from 0 to 100.0%. Twice this time will be taken to adjust the output from -100.0% to +100.0%.

9.24	Motorised pot scale factor															
Coding	Bit	SP	FI	DE	Txt	VM	DP	ND	RA	NC	NV	PT	US	RW	BU	PS
							3						1	1	1	
Range	0.000 to 4.000															
Default	1.000															
Update rate	Background															

This parameter can be used to restrict the output of the motorised pot to operate over a reduced range so that it can be used as a trim for example. There is an automatic scaling such that when this parameter is set to 1.000, a 100% level on the motorised pot will cause the programmed destination parameter to be at its maximum value.

9.25	Motorised pot destination															
Coding	Bit	SP	FI	DE	Txt	VM	DP	ND	RA	NC	NV	PT	US	RW	BU	PS
			1				2					1	1	1	1	
Range	Pr 1.01 to Pr 21.51															
Default	Pr 0.00															
Update rate	Read on drive reset															

This needs to be set up with the parameter that the motorised pot is to control. Only non bit parameters which are not protected can be controlled by the motorised pot function, if a non valid parameter is programmed the output is not routed anywhere. If the motorised pot is to control speed then it is suggested that one of the preset speed parameters is entered here.

9.26	Motorised pot up															
9.27	Motorised pot down															
9.28	Motorised pot reset															
Coding	Bit	SP	FI	DE	Txt	VM	DP	ND	RA	NC	NV	PT	US	RW	BU	PS
	1									1				1		
Range	0 or 1															
Default	0															
Update rate	21 ms															

These three bits control the motorised pot. The up and down inputs increase and decrease the output at the programmed rate respectively. If both up and down are active together the up function dominates and the output increases. If the reset input is set to 1, the motorised pot output is reset and held at 0.0%.

Input terminals must be programmed to control these parameters to implement the motorised pot.

9.29	Binary sum one's input															
9.30	Binary sum two's input															
9.31	Binary sum four's input															
Coding	Bit	SP	FI	DE	Txt	VM	DP	ND	RA	NC	NV	PT	US	RW	BU	PS
	1									1				1		
Range	0 or 1															
Default	0															
Update rate	21 ms															

9.32	Binary sum output															
Coding	Bit	SP	FI	DE	Txt	VM	DP	ND	RA	NC	NV	PT	US	RW	BU	PS
								1		1		1	1		1	
Range	0 to 255															
Update rate	21 ms															

9.33	Binary sum destination															
Coding	Bit	SP	FI	DE	Txt	VM	DP	ND	RA	NC	NV	PT	US	RW	BU	PS
				1			2					1	1	1	1	
Range	Pr 1.01 to Pr 21.51															
Default	Pr 0.00															
Update rate	Read on drive reset															

9.34	Binary sum offset															
Coding	Bit	SP	FI	DE	Txt	VM	DP	ND	RA	NC	NV	PT	US	RW	BU	PS
													1	1	1	
Range	0 to 248															
Default	0															
Update rate	21 ms															

The binary sum output is given by:

$$\text{One's input} + (2 \times \text{two's input}) + (4 \times \text{four's input}) + \text{Offset}$$

The value written to the destination parameter is defined as follows:

If maximum of the destination parameter is $\leq (7 + \text{offset})$:

The value in the destination parameter = the binary sum output (Pr 9.32)

If maximum of the destination parameter $> (7 + \text{offset})$:

The value in the destination parameter =
Destination parameter maximum \times Binary sum output (Pr 9.32) / $(7 + \text{offset})$

The table below shows how the binary sum function operates with 0 offset.

Ones input (Pr 9.29)	Twos input (Pr 9.30)	Fours input (Pr 9.31)	Binary sum output (Pr 9.32)	Value in destination parameter	
				Destination parameter with a maximum value of 7 or less, i.e. Pr 6.01 with a range of 0 to 4	Destination parameter with a maximum value of greater than 7, i.e. Pr 5.23 with a range of 0.0 to 25.0
0	0	0	0	0	0.0
1	0	0	1	1	3.6
0	1	0	2	2	7.1
1	1	0	3	3	10.7
0	0	1	4	4	14.3
1	0	1	5	4	17.8
0	1	1	6	4	21.4
1	1	1	7	4	25.0

If the parameter that the binary sum value is routed to has a maximum value of less than 7 then the destination parameter will be limited to the correct value for that parameter independent of the binary sum output.

If the parameter that the binary sum value is routed to has a maximum value greater than 7 then the binary sum output will be scaled evenly across the maximum range of the destination parameter

The table below shows how the binary sum function operates with an offset value.

Ones input (Pr 9.29)	Twos input (Pr 9.30)	Fours input (Pr 9.31)	Offset (Pr 9.34)	Binary sum output (Pr 9.32)	Value in destination parameter	
					Destination parameter with a maximum value of (7 + offset) or less, i.e. Pr 1.15 with a range of 0 to 8	Destination parameter with a maximum value of greater than 7, i.e. Pr 5.23 with a range of 0.0 to 25.0
0	0	0	3	3	3	7.5
1	0	0		4	4	10.0
0	1	0		5	5	12.5
1	1	0		6	6	15.0
0	0	1		7	7	17.5
1	0	1		8	8	20.0
0	1	1		9	8	22.5
1	1	1		10	8	25.0

9.11 Menu 10: Status logic and diagnostic information

Table 9-12 Menu 10 parameters: single line descriptions

Parameter		Range	Default	Setting	Update Rate
10.01	Drive healthy	0 or 1			B
10.02	Drive active	0 or 1			B
10.03	Zero speed	0 or 1			B
10.04	Running at or below minimum speed	0 or 1			B
10.05	Below set speed	0 or 1			B
10.06	At speed	0 or 1			B
10.07	Above set speed	0 or 1			B
10.08	Load reached	0 or 1			B
10.09	Drive output is at current limit	0 or 1			B
10.10	Regenerating	0 or 1			B
10.11	Dynamic brake active	0 or 1			B
10.12	Braking resistor alarm	0 or 1			B
10.13	Direction commanded	0 or 1			B
10.14	Direction running	0 or 1			B
10.15	Mains loss	0 or 1			B
10.16	Not used				
10.17	Overload alarm	0 or 1			B
10.18	Drive temperature alarm	0 or 1			B
10.19	General drive alarm	0 or 1			B
10.20	Last trip	{55} 0 to 230			On drive trip
10.21	Trip 1	{56} 0 to 230			On drive trip
10.22	Trip 2	{57} 0 to 230			On drive trip
10.23	Trip 3	{58} 0 to 230			On drive trip
10.24	Trip 4	0 to 230			On drive trip
10.25	Trip 5	0 to 230			On drive trip
10.26	Trip 6	0 to 230			On drive trip
10.27	Trip 7	0 to 230			On drive trip
10.28	Trip 8	0 to 230			On drive trip
10.29	Trip 9	0 to 230			On drive trip
10.30	Full power braking time	0.00 to 320.00 s	0.0		B
10.31	Full power braking period	0.0 to 1500.0 s	0.0		B
10.32	External trip	0 or 1	0		B
10.33	Drive reset	0 or 1	0		21 ms
10.34	No. of auto reset attempts	0 to 5	0		B
10.35	Auto reset delay	0.0 to 25.0 s	1.0		B
10.36	Hold 'drive healthy' until last attempt	0 or 1	0		B
10.37	Action on trip detection	0 to 3	0		B
10.38	User trip	0 to 255	0		B
10.39	Braking energy overload accumulator	0.0 to 100.0%			B
10.40	Status word	0 to 32767			B

10.01	Drive healthy															
Coding	Bit	SP	FI	DE	Txt	VM	DP	ND	RA	NC	NV	PT	US	RW	BU	PS
	1							1		1		1				
Range	0 or 1															
Update rate	Background															

Indicates the drive is not in the trip state. If Pr **10.36** is 1 and an auto-reset is being used, this bit is not cleared until all auto-resets have been attempted and the next trip occurs.

10.02	Drive active															
Coding	Bit	SP	FI	DE	Txt	VM	DP	ND	RA	NC	NV	PT	US	RW	BU	PS
	1							1		1		1				
Range	0 or 1															
Update rate	Background															

Indicates that the inverter output is active.

10.03	Zero speed															
Coding	Bit	SP	FI	DE	Txt	VM	DP	ND	RA	NC	NV	PT	US	RW	BU	PS
	1							1		1		1				
Range	0 or 1															
Update rate	Background															

This bit is set to 1 when the absolute value of the ramp output is at or below the threshold programmed into Pr **3.05**.

10.04	Running at or below minimum speed															
Coding	Bit	SP	FI	DE	Txt	VM	DP	ND	RA	NC	NV	PT	US	RW	BU	PS
	1							1		1		1				
Range	0 or 1															
Update rate	Background															

In bipolar mode (Pr **1.10** = 1) this parameter is the same as zero speed (Pr **10.03**).

In unipolar mode, this parameter is set if the absolute value of the ramp output is at or below minimum speed + 0.5Hz. Minimum speed is defined by Pr **1.07**.

The parameter is only set if the drive is running.

10.05	Below set speed															
10.06	At speed															
10.07	Above set speed															
Coding	Bit	SP	FI	DE	Txt	VM	DP	ND	RA	NC	NV	PT	US	RW	BU	PS
	1							1		1		1				
Range	0 or 1															
Update rate	Background															

These flags are set by the speed detector in menu 3. These flags are only set if the drive is running.

See Pr **3.06** on page 42.

10.08	Load reached															
Coding	Bit	SP	FI	DE	Txt	VM	DP	ND	RA	NC	NV	PT	US	RW	BU	PS
	1							1		1		1				
Range	0 or 1															
Update rate	Background															

Indicates that the modulus of the active current is greater or equal to the rated active current as defined in menu 4.

10.09	Drive output is at current limit															
Coding	Bit	SP	FI	DE	Txt	VM	DP	ND	RA	NC	NV	PT	US	RW	BU	PS
	1							1		1		1				
Range	0 or 1															
Update rate	Background															

Indicates that the normal current limits are active.

10.10	Regenerating															
Coding	Bit	SP	FI	DE	Txt	VM	DP	ND	RA	NC	NV	PT	US	RW	BU	PS
	1							1		1		1				
Range	0 or 1															
Update rate	Background															

Indicates that power is being transferred from the motor to the drive.

10.11	Dynamic brake active															
Coding	Bit	SP	FI	DE	Txt	VM	DP	ND	RA	NC	NV	PT	US	RW	BU	PS
	1							1		1		1				
Range	0 or 1															
Update rate	Background															

Indicates that the braking IGBT is active. If the IGBT becomes active this parameter is held on for at least 0.5s so that it can be seen on the display.

10.12	Brake resistor alarm															
Coding	Bit	SP	FI	DE	Txt	VM	DP	ND	RA	NC	NV	PT	US	RW	BU	PS
	1							1		1		1				
Range	0 or 1															
Update rate	Background															

This parameter is set when the braking IGBT is active and the braking energy overload accumulator is greater than 75% (Pr 10.39). This parameter is held on for at least 0.5s so that it can be seen on the display.

10.13	Direction commanded															
Coding	Bit	SP	FI	DE	Txt	VM	DP	ND	RA	NC	NV	PT	US	RW	BU	PS
	1							1		1		1				
Range	0 or 1															
Update rate	Background															

This parameter is set if the pre-ramp reference (Pr 1.03) is negative (reverse), reset if pre-ramp reference is positive (forward).

10.14	Direction running															
Coding	Bit	SP	FI	DE	Txt	VM	DP	ND	RA	NC	NV	PT	US	RW	BU	PS
	1							1		1		1				
Range	0 or 1															
Update rate	Background															

This parameter is set if the post-ramp reference (Pr 2.01) is negative (reverse), or reset if post-ramp reference is positive (forward).

10.15	Mains loss															
Coding	Bit	SP	FI	DE	Txt	VM	DP	ND	RA	NC	NV	PT	US	RW	BU	PS
	1							1		1		1				
Range	0 or 1															
Update rate	Background															

Indicates that the drive has detected mains loss from the level of the DC bus voltage. This parameter can only become active if mains loss ride through or mains loss stop modes are selected (see Pr 6.03 on page 69).

10.16	Unused parameter														
--------------	-------------------------	--	--	--	--	--	--	--	--	--	--	--	--	--	--

10.17	Overload alarm															
Coding	Bit	SP	FI	DE	Txt	VM	DP	ND	RA	NC	NV	PT	US	RW	BU	PS
	1							1		1		1				
Range	0 or 1															
Update rate	Background															

This parameter is set if the drive output current is larger than 105% of rated current (Pr **5.07**) and the overload accumulator is greater than 75% to warn that if the motor current is not reduced the drive will trip on an Ixt overload. (If the rated current [Pr **5.07**] is set to a level above the rated drive current [Pr **11.32**] the overload alarm is given when the current is higher than 100% of rated current.)

10.18	Drive temperature alarm															
Coding	Bit	SP	FI	DE	Txt	VM	DP	ND	RA	NC	NV	PT	US	RW	BU	PS
	1							1		1		1				
Range	0 or 1															
Update rate	Background															

This flag is set if the IGBT junction temperature calculated from the drive thermal model is above 135°C, or if the heat sink temperature has made the switching frequency decrease.

The following table indicates how the switching frequency is controlled:

Drive condition	Action
Heat sink > 95°C	Trip drive
Heat sink > 92°C	Reduce switching frequency to 3kHz
Heat sink > 88°C	Reduce switching frequency to 6kHz
Heat sink > 85°C	Reduce switching frequency to 12kHz
IGBT temp > 135°C	Reduce switching frequency, if it is minimum trip drive

The switching frequency and drive thermal model are updated once per second. Whenever the drive has reduced the switching frequency this alarm is set.

10.19	General drive alarm															
Coding	Bit	SP	FI	DE	Txt	VM	DP	ND	RA	NC	NV	PT	US	RW	BU	PS
	1							1		1		1				
Range	0 or 1															
Update rate	Background															

This flag is set if any of the other drive alarms are active, i.e. *Drive temperature alarm*, *Overload alarm* or *Dynamic brake alarm*.

Pr **10.19** = Pr **10.18** or Pr **10.17** or Pr **10.12**

10.20	Last trip															
10.21	Trip 1															
10.22	Trip 2															
10.23	Trip 3															
10.24	Trip 4															
10.25	Trip 5															
10.26	Trip 6															
10.27	Trip 7															
10.28	Trip 8															
10.29	Trip 9															
Coding	Bit	SP	FI	DE	Txt	VM	DP	ND	RA	NC	NV	PT	US	RW	BU	PS
					1			1		1		1			1	1
Range	0 to 230															
Update rate	On drive trip															

Contains the last 10 drive trips. Pr **10.20** is the most recent trip and Pr **10.29** the oldest. When a new trip occurs all the parameters move down one, the current trip is put in 10.20 and the oldest trip is lost off the bottom of the log. Possible trips for Commander SK are shown in Table 9-13 on page 108. All trips are stored including HF trips which are numbered from 20 to 30. (HF trips below numbered from 1 to 19 are not stored in the trip log.) UU trips are not stored unless the drive is running when the trip occurs. Any trip can be initiated by the actions described or by writing the relevant trip number to Pr **10.38**. If any trips shown as user trips are initiated the trip string is "bxxx", where xxx is the trip number.

Table 9-13 Trip indications

No.	String	Cause of trip
1	UU	DC bus under voltage
2	OU	DC bus over voltage. Drive voltage rating Instantaneous trip 200V 415V 400V 830V
3	OI.AC	AC instantaneous over current.
4	OI.br	Braking resistor instantaneous current trip.
6	Et	External trip (see Pr 10.32 on page 111)
7	O.SPd	Overspeed
18	tunE	Auto-tune stopped before completion (see Pr 5.12 on page 60)
19	It.br	I ² t on braking resistor (see Pr 10.31 on page 110)
20	It.AC	I ² t on drive output current (see Pr 4.15 on page 51)
21	O.ht1	Drive over-heat (IGBT junctions) based on thermal model (see Pr 5.18 on page 63)
22	O.ht2	Drive over-heat based on heatsink temperature (see Pr 7.04 on page 82)
24	th	Motor thermistor trip
26	O.Ld1	+24V or Digital output overload
27	O.ht3	Drive over-heat based on thermal model (see Pr 7.35 on page 86) The drive will attempt to stop the motor before tripping. If the motor does not stop in 10 seconds the drive trips immediately.
28	cL1	Analog input 1 current mode: current loss (see Pr 7.06 on page 82)
30	SCL	Serial comms timeout with external keypad on drives comms port
31	EEF	Internal drive EEPROM failure. All the parameters are set to default. The trip can only be removed by entering a load default command (see Pr 11.43 on page 124)
32	PH	High input voltage phase imbalance or input phase loss. Normally a motor load of between 50 and 100% or drive rating is required to trigger the trip. The drive will attempt to stop the motor before tripping.
33	rS	Failure to measure resistance during auto-tune or when starting in open-loop voltage modes 0 or 3. This is either because the resistance exceeds the maximum measurable value or no motor connected to drive (see Pr 5.12 on page 60, Pr 5.14 and Pr 5.17 on page 62)
35	CL.bt	Trip initiated from the control word (see Pr 6.42 on page 78)
40-89	t040 - t089	User trips
90	t090	Drive user program error - divide by zero
91	t091	Drive user program error - parameter does not exist
92	t092	Drive user program error - parameter is read only
93	t093	Drive user program error - parameter write over range
94	t094	Drive user program error - virtual memory stack overflow
95	t095	Drive user program error - LogicStick removed
96	t096	Drive user program error - invalid operating system call
97	t097	Drive user program error - invalid instruction
98	t098	Drive user program error - invalid function block argument
99	t099	User trip
100		Drive reset (see Pr 10.38 on page 112)
182	C.Err	Card data error: The file access is corrupted. Pr 11.42 is set to 3 or 4 and a parameter is changed in menu 0 before reset is activated.
183	C.dAt	Data does not exist: An attempt has been made to transfer data from a blank card or data block that does not exist.
185	C.Acc	Card read/write fail: The drive cannot communicate with the card either because it is faulty or is not fitted in the drive. Removing a card during an access will cause this trip.
186	C.rtg	Rating change: The parameters loaded to the drive from a card are for a drive of a different voltage or current rating. No rating dependent parameters have been transferred.
189	O.cL	Overload on current loop input
199	dESt	Destination parameter clash
200	SI.HF	Option module hardware fault. This could occur because the module cannot be identified, or the module has not indicated it is running within 5s of drive power-up, or an internal hardware fault has occurred in the module.
201	SI.tO	Option module watchdog timeout. The module has started the watchdog system, but has not subsequently serviced the watchdog within the timeout period.
202	SI.Er	Option module error. The module has detected an error and tripped the drive. The reason for the error is stored in Pr 15.50

No.	String	Cause of trip
203	Sl.nF	Option module not fitted. The option module is identified by the drive by an option code. The drive stores the codes of the modules fitted when the drive parameters are saved. The stored codes are compared with the codes from the option modules at power-up. If a module is not present, but a code is stored in drive EEPROM to indicate that it should be fitted the drive trips. If the module is removed after power-up the drive produces this trip within 4ms.
204	Sl.dF	Option module different fitted. The option module is identified by the drive by an option code. The drive stores the codes of the modules fitted when the drive parameters are saved. The stored codes are compared with the codes from the option modules at power-up. If a module is different to the code stored in drive EEPROM the drive trips.
220 to 230	HF20 - HF30	Hardware faults (See table Table 9-15 <i>HF trips</i>)

Trips can be grouped into the following categories:

Category	Trips	Comments
Hardware faults	HF01 to HF19	These indicate fatal problems and cannot be reset. The drive is inactive after one of these trips and the display shows HFxx. The serial communications is inactive and the parameters cannot be accessed.
Self resetting trips	UU	Under voltage trip cannot be reset by the user, but is automatically reset by the drive when the supply voltage is within specification (See table Table 9-14 <i>Under voltage trip and restart levels</i>)
Non-resetable trips	HF20 to HF30, Sl.HF	Cannot be reset. The serial communications is active and parameters can be accessed.
EEF trip	EEF	Cannot be reset unless a default parameter set has been loaded.
Normal trips	All other trips	Can be reset after 1.0s
Normal trips with extended reset	OI.AC, OI.br	Can be reset after 10.0s
Low priority trips	O.Ld1, CL1, SCL	If Pr 10.37 is 1 or 3 the drive will stop before tripping.
Phase loss	PH	The drive stops before tripping provided the drive motoring power is suitably reduced after 500ms of detecting phase loss

Table 9-14 Under voltage trip and restart levels

Drive voltage rating	UU trip level	UU restart level
200	175	215
400	330	425

Table 9-15 HF trips

HF fault code	Reason for trip
01 to 04	Not used
05	No signal from DSP at start up
06	Unexpected interrupt
07	Watchdog failure
08	Interrupt crash (code overrun)
09 to 10	Not used
11	Access to the EEPROM failed
12 to 19	Not used
20	Power stage - code error
21	Power stage - unrecognised frame size
22	OI failure at power up
23 to 24	Not used
25	DSP Communications failure
26	Soft start relay failed to close, or soft start monitor failed, or braking IGBT short circuit at power up
27	Power stage thermistor fault
28	DSP software overrun
29 to 30	Not used

The braking IGBT continues to operate even when the drive is not enabled, and is only disabled if one of the following trips occurs or would occur if another trip has not already become active: OI.br or It.br.

It should be noted that although the UU trip operates in a similar way to all other trips, all drive functions can still operate, but the drive cannot be enabled. Parameter values are only loaded from EEPROM if the supply voltage is low enough for the switch mode power supply in the drive to shut down and then it is increased to restart the drive power supplies. The only differences between UU and other trips are as follows:

1. Power down save user parameters are saved when UU trip is activated.
2. The UU trip is self-resetting when the DC bus voltage rises above the drive restart voltage level.

3. When the drive is first powered up a UU trip is initiated if the supply voltage is below the restart voltage level. This does not save power down save parameters. If another trip occurs during power-up it is the active trip in preference to the UU trip. If this trip is cleared and the supply voltage is still below the restart voltage threshold a UU trip is then initiated.

Table 9-16 Alarm Warnings

Display	Condition
OVL.d	Ixt overload (see Pr 4.15, Pr 4.16 on page 51, Pr 4.19 on page 53 and Pr 10.17 on page 107)
hot	Heatsink/IGBT temperature too high (see Pr 5.18 on page 63, Pr 5.35 on page 65 and Pr 10.18 on page 107)
br.rS	Ixt overload on braking resistor (see Pr 10.12 on page 106, Pr 10.30 and Pr 10.31)

10.30	Full power braking time
Coding	Bit SP FI DE Txt VM DP ND RA NC NV PT US RW BU PS
Range	0.00 to 320.00 s
Default	0.00
Update rate	Background

This parameter defines the time period that the braking resistor fitted can stand full braking volts without damage. The setting of this parameter is used in determining the braking overload time.

Drive voltage rating	Full braking volts
200V	390V
400V	780V

10.31	Full power braking period
Coding	Bit SP FI DE Txt VM DP ND RA NC NV PT US RW BU PS
Range	0.0 to 1500.0 s
Default	0.0
Update rate	Background

This parameter defines the time period which must elapse between consecutive braking periods of maximum braking power as defined by Pr 10.30. The setting of this parameter is used in determining the thermal time constant of the resistor fitted. It is assumed that the temperature will fall by 99% in this time, and so the time constant is Pr 10.30 / 5. If either Pr 10.30 or Pr 10.31 are is set to 0 then no braking resistor protection is implemented. The braking resistor temperature is modelled by the drive as shown below. The temperature rises in proportion to the power flowing into the resistor and falls in proportion to the difference between the resistor temperature and ambient.

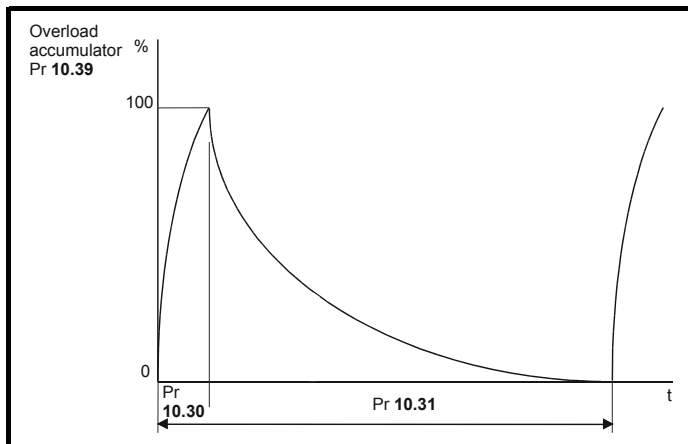

Assuming that the full power braking time is much shorter than the full power braking period (which is normally the case) the values for Pr 10.30 and Pr 10.31 can be calculated as follows:

Power flowing into the resistor when the braking IGBT is on, $P_{on} = \text{Full braking volts}^2 / R$

Where:

Full braking volts is defined in the table (see Pr 10.30) and R is the resistance of the braking resistor.

Full power braking time (Pr 10.30), $T_{on} = E / P_{on}$

Where:

E is the total energy that can be absorbed by the resistor when its initial temperature is ambient temperature.

Therefore full power braking time (Pr 10.30), $T_{on} = E \times R / \text{Full braking volts}^2$

If the cycle shown in the diagram previously is repeated, where the resistor is heated to its maximum temperature and then cools to ambient:

The average power in the resistor $P_{av} = P_{on} \times T_{on} / T_p$

Where:

T_p is the full power braking period

$P_{on} = E / T_{on}$

Therefore $P_{av} = E / T_p$

Therefore full power braking period (Pr 10.31) $T_p = E / P_{av}$

The resistance of the braking resistor R, the total energy E and the average power P_{av} can normally be obtained for the resistor and used to calculate Pr 10.30 and Pr 10.31.

The temperature of the resistor is monitored by the braking energy accumulator (Pr 10.39). When this parameter reaches 100% the drive will trip if Pr 10.37 is 0 or 1, or will disable the braking IGBT until the accumulator falls below 95% if Pr 10.37 is 2 or 3. The second option is intended for applications with parallel connected DC buses where there are several braking resistors, each of which cannot withstand full DC bus voltage continuously. The braking load will probably not be shared equally between the resistors because of voltage measurement tolerances within the individual drives. However, once a resistor reaches its maximum temperature its load will be reduced, and be taken up by another resistor.

10.32	External trip															
Coding	Bit	SP	FI	DE	Txt	VM	DP	ND	RA	NC	NV	PT	US	RW	BU	PS
	1									1				1		
Range	0 or 1															
Default	0															
Update rate	Background															

If this flag is set to 1 then the drive will trip (Et). If an external trip function is required, a digital input should be programmed to control this bit (see section 9.9 Menu 8: Digital inputs and outputs on page 87).

10.33	Drive reset															
Coding	Bit	SP	FI	DE	Txt	VM	DP	ND	RA	NC	NV	PT	US	RW	BU	PS
	1									1				1		
Range	0 or 1															
Default	0															
Update rate	21 ms															

A 0 to 1 change on this parameter will cause a drive reset. If a drive reset terminal is required on the drive the required terminal must be programmed to control this bit.

10.34	No. of auto-reset attempts															
Coding	Bit	SP	FI	DE	Txt	VM	DP	ND	RA	NC	NV	PT	US	RW	BU	PS
													1	1	1	
Range	0 to 5															
Default	0															
Update rate	Background															

10.35	Auto-reset delay															
Coding	Bit	SP	FI	DE	Txt	VM	DP	ND	RA	NC	NV	PT	US	RW	BU	PS
							1						1	1	1	
Range	0.0 to 25.0 s															
Default	1.0															
Update rate	Background															

If Pr 10.34 is set to zero then no auto reset attempts are made. Any other value will cause the drive to automatically reset following a trip for the number of times programmed. Pr 10.35 defines the time between the trip and the auto reset (this time is always at least 10s for OI.AC, OI.br trips, etc.). The reset count is only incremented when the trip is the same as the previous trip, otherwise it is reset to 0. When the reset count reaches the programmed value, any further trip of the same value will not cause an auto-reset. If there has been no trip for 5 minutes then the reset count is cleared. Auto reset will not occur on UU, Et, EEF or HFxx trips. When a manual reset occurs the auto reset counter is reset to zero.

10.36	Hold 'drive healthy' until last attempt															
Coding	Bit	SP	FI	DE	Txt	VM	DP	ND	RA	NC	NV	PT	US	RW	BU	PS
	1												1	1		
Range	0 or 1															
Default	0															
Update rate	Background															

If this parameter is 0 then Pr 10.01 (*Drive healthy*) is cleared every time the drive trips regardless of any auto-reset that may occur. When this parameter is set, the 'drive healthy' indication is not cleared on a trip if an auto-reset is going to occur.

10.37	Action on trip detection															
Coding	Bit	SP	FI	DE	Txt	VM	DP	ND	RA	NC	NV	PT	US	RW	BU	PS
													1	1	1	
Range	0 to 3															
Default	0															
Update rate	Background															

	Braking IGBT trip mode	Stop on low priority trips
0	Trip	No
1	Trip	Yes
2	Disable	No
3	Disable	Yes

For details of braking IGBT trip mode see Pr 10.31 on page 110.

If stop on low priority trips is selected the drive will stop before tripping. Low priority trips are: th, O.Ld1, cL1, and SCL.

10.38	User trip															
Coding	Bit	SP	FI	DE	Txt	VM	DP	ND	RA	NC	NV	PT	US	RW	BU	PS
													1	1	1	
Range	0 to 255															
Default	0															
Update rate	Background															

This parameter is used to generate user trips over the serial comms. Valid trip codes are numbers which are not values already used by the drive and are not 100 or 255. Writing a trip code that already exists causes that trip to occur. User generated trips will be indicated by txxx in the trip log where xxx is the trip code.

Users wishing to reset the drive over the serial comms can do so by writing a value of 100 to this parameter. Writing a value of 255 to this parameter will cause the trip log to be cleared. When the drive has detected a write to this parameter it immediately writes the value back to zero.

NOTE

It is not possible to generate UU, EEF or HF trips using Pr 10.38.

10.39	Braking energy overload accumulator															
Coding	Bit	SP	FI	DE	Txt	VM	DP	ND	RA	NC	NV	PT	US	RW	BU	PS
							1	1		1		1			1	
Range	0.0 to 100.0 %															
Update rate	Background															

This parameter gives an indication of braking resistor temperature based on a simple thermal model, see Pr 10.30 and Pr 10.31 on page 110. Zero indicates the resistor is close to ambient and 100% is the maximum temperature (trip level). A br.rS warning is given if this parameter is above 75% and the braking IGBT is active.

10.40	Status word															
Coding	Bit	SP	FI	DE	Txt	VM	DP	ND	RA	NC	NV	PT	US	RW	BU	PS
								1		1		1			1	
Range	0 to 32767															
Update rate	Background															

The bits in this parameter correspond to the status bits in menu 10 as follows.

15	14	13	12	11	10	9	8
Not used	Pr 10.15	Pr 10.14	Pr 10.13	Pr 10.12	Pr 10.11	Pr 10.10	Pr 10.09
7	6	5	4	3	2	1	0
Pr 10.08	Pr 10.07	Pr 10.06	Pr 10.05	Pr 10.04	Pr 10.03	Pr 10.02	Pr 10.01

9.12 Menu 11: General drive set-up

Table 9-17 Menu 11 parameters: single line descriptions

Parameter		Range	Default	Setting	Update Rate
11.01	Pr 61 set-up {61}	Pr 0.00 to Pr 21.51	Pr 0.00		B
11.02	Pr 62 set-up {62}	Pr 0.00 to Pr 21.51	Pr 0.00		B
11.03	Pr 63 set-up {63}	Pr 0.00 to Pr 21.51	Pr 0.00		B
11.04	Pr 64 set-up {64}	Pr 0.00 to Pr 21.51	Pr 0.00		B
11.05	Pr 65 set-up {65}	Pr 0.00 to Pr 21.51	Pr 0.00		B
11.06	Pr 66 set-up {66}	Pr 0.00 to Pr 21.51	Pr 0.00		B
11.07	Pr 67 set-up {67}	Pr 0.00 to Pr 21.51	Pr 0.00		B
11.08	Pr 68 set-up {68}	Pr 0.00 to Pr 21.51	Pr 0.00		B
11.09	Pr 69 set-up {69}	Pr 0.00 to Pr 21.51	Pr 0.00		B
11.10	Pr 70 set-up {70}	Pr 0.00 to Pr 21.51	Pr 0.00		B
11.11	Not used				
11.12	Not used				
11.13	Not used				
11.14	Not used				
11.15	Not used				
11.16	Not used				
11.17	Not used				
11.18	Not used				
11.19	Not used				
11.20	Not used				
11.21	Parameter scaling {24}	0.000 to 9.999	1.000		B
11.22	Parameter displayed at power up	0 or 1	0		N/A
11.23	Serial address {44}	0 to 247	1		B
11.24	Modbus RTU / user serial mode	0 to 3	1		B
11.25	Baud rate {43}	0 to 4	3		B
11.26	Silent period extension	0 to 250 ms	2		B
11.27	Drive configuration {05}	0 to 8	0		Drive reset
11.28	Not used				
11.29	Software version {45}	0.00 to 99.99			N/A
11.30	User security code {25}	0 to 999			B
11.31	Not used				
11.32	Maximum heavy duty drive current rating	0.00 to 290.00 A			N/A
11.33	Voltage rating	0 to 2			N/A
11.34	Software sub-version	0 to 99			N/A
11.35	DSP software version	0.0 to 9.9			N/A
11.36	Not used				
11.37	Not used				
11.38	Not used				
11.39	Not used				
11.40	Not used				
11.41	Status mode timeout	0 to 250 s	240		B
11.42	Parameter cloning {28}	0 to 4	0		Drive reset
11.43	Load defaults {29}	0 to 3	0		Drive reset
11.44	Security status {10}	0 to 3	0		Drive reset
11.45	Select motor 2 parameters	0 or 1	0		B
11.46	Defaults previously loaded	0 to 2	0		BW
11.47	Drive user program enable	0 to 2	2		BR
11.48	Drive user program status	-128 to 127			BW
11.49	Not used				
11.50	User program maximum scan time	0 to 65535 ms			User program

11.01	Pr 61 set-up															
11.02	Pr 62 set-up															
11.03	Pr 63 set-up															
11.04	Pr 64 set-up															
11.05	Pr 65 set-up															
11.06	Pr 66 set-up															
11.07	Pr 67 set-up															
11.08	Pr 68 set-up															
11.09	Pr 69 set-up															
11.10	Pr 70 set-up															
Coding	Bit	SP	FI	DE	Txt	VM	DP	ND	RA	NC	NV	PT	US	RW	BU	PS
							2					1	1	1	1	
Range	Pr 0.00 to Pr 21.51															
Default	Pr 0.00															
Update rate	Background															

These parameters define the parameters that reside in the programmable area in level 2 of the basic parameter set.

11.11 to 11.20	Unused parameters
----------------	-------------------

11.21	Parameter scaling															
Coding	Bit	SP	FI	DE	Txt	VM	DP	ND	RA	NC	NV	PT	US	RW	BU	PS
							3						1	1	1	
Range	0.000 to 9.999															
Default	1.000															
Update rate	Background															

When customer defined units are selected as the display units this parameter is used to scale the RPM (Pr 5.04) to give the displayed units. See Pr 5.34 on page 65.

NOTE

When speeds greater than 9999 rpm are to be displayed, set Pr 11.21 to 0.1 or 0.01.

Example:

Maximum speed of 30000 rpm. Set Pr 11.21 to 0.1, 30000 rpm = 3000 on display

11.22	Parameter displayed at power-up															
Coding	Bit	SP	FI	DE	Txt	VM	DP	ND	RA	NC	NV	PT	US	RW	BU	PS
	1												1	1		
Range	0 or 1															
Default	0															
Update rate	N/A															

- 0: Speed
- 1: Load

This parameter defines which parameter is displayed at power-up, either the speed or the load. This parameter is written to automatically when the user switches between speed and load indications in parameter status mode by holding the Mode button down for a period of 2 seconds. In this case the parameter is saved automatically by the drive, if the user changes this parameter using serial communication it is not saved automatically.

11.23	Serial address															
Coding	Bit	SP	FI	DE	Txt	VM	DP	ND	RA	NC	NV	PT	US	RW	BU	PS
													1	1	1	
Range	0 to 247															
Default	1															
Update rate	Background															

This parameter is used to define the unique address for the drive for the serial interface. The drive is always a slave.

Address 0 is used to globally address all slaves, and so this address should not be set in this parameter.

The communications port on the Sequel will support Modbus RTU protocol only. Full details of the CT implementation of Modbus RTU are given in "CT MODBUS RTU specification".

The protocol provides the following facilities:

- Drive parameter access with basic Modbus RTU
- Drive parameter database upload via CMP extensions

The following product specific limitations apply:

- Maximum slave response time when accessing the drive is 100ms
- Maximum number of 16 bit registers that can be written to, or read from, the drive itself is limited to 16
- The communications buffer can hold a maximum of 128 bytes

11.24	Modbus RTU / user serial mode															
Coding	Bit	SP	FI	DE	Txt	VM	DP	ND	RA	NC	NV	PT	US	RW	BU	PS
													1	1	1	
Range	0 to 3															
Default	1															
Update rate	Background															

Modes 0 and 1 are for Modbus slave mode. Modes 2 and 3 allow a drive user program to control the comms.

- 0: mode 0 8 data bit and 1 stop bit with no parity (Commander SE backward compatibility)
- 1: mode 1 8 data bit and 2 stop bits with no parity
- 2: mode 2 7 data bit and 1 stop bit with even parity
- 3: mode 3 8 data bit and 2 stop bits with no parity

11.25	Baud rate															
Coding	Bit	SP	FI	DE	Txt	VM	DP	ND	RA	NC	NV	PT	US	RW	BU	PS
					1								1	1	1	
Range	0 (2.4 kB), 1 (4.8 kB), 2 (9.6 kB), 3 (19.2 kB), 4 (38.4 kB)															
Default	3 (19.2 kB)															
Update rate	Background															

This parameter is used to select the comms port baud rate.

11.26	Silent period extension															
Coding	Bit	SP	FI	DE	Txt	VM	DP	ND	RA	NC	NV	PT	US	RW	BU	PS
													1	1	1	
Range	0 to 250 ms															
Default	2															
Update rate	Background															

Modbus RTU uses a silent period detection system to detect the end of a message. This silent period is normally the length of time for 3.5 characters at the present baud rate, but for systems that cannot turn the communications buffers around fast enough this time can be extended to the time programmed in Pr 11.26.

11.27	Drive configuration															
Coding	Bit	SP	FI	DE	Txt	VM	DP	ND	RA	NC	NV	PT	US	RW	BU	PS
					1							1	1	1	1	
Range	0 to 8															
Default	0 (AI.AV)															
Update rate	Actioned on exit of edit mode and on drive reset															

This parameter is used to automatically setup the user programmable area in the level 2 parameter set according to drive configurations. Other default values may also be changed by drive configuration. Parameters are stored in EEPROM automatically following a configuration change. See menu 0 for description. Defaults are loaded before drive configuration changes are made. Defaults loaded are defined by Pr 11.46. Action will only occur if the drive is inactive. If the drive is active the parameter will return to its pre altered value on exit from edit mode. In all of the settings below, the status relay is set up as the drive healthy relay.

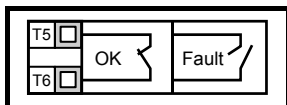

Pr 11.27	Configuration	Description
0	AI.AV	Voltage and current input
1	AV.Pr	Voltage input and 3 preset speeds
2	AI.Pr	Current input and 3 preset speeds
3	Pr	4 preset speeds
4	PAd	Keypad control
5	E.Pot	Electronic motorised potentiometer control
6	tor	Torque control operation
7	Pid	PID control
8	HUAC	Fan and pump control

Figure 9-25 Key to switches

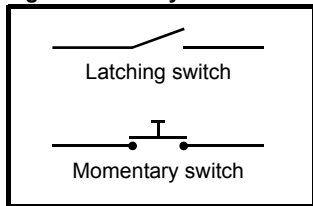
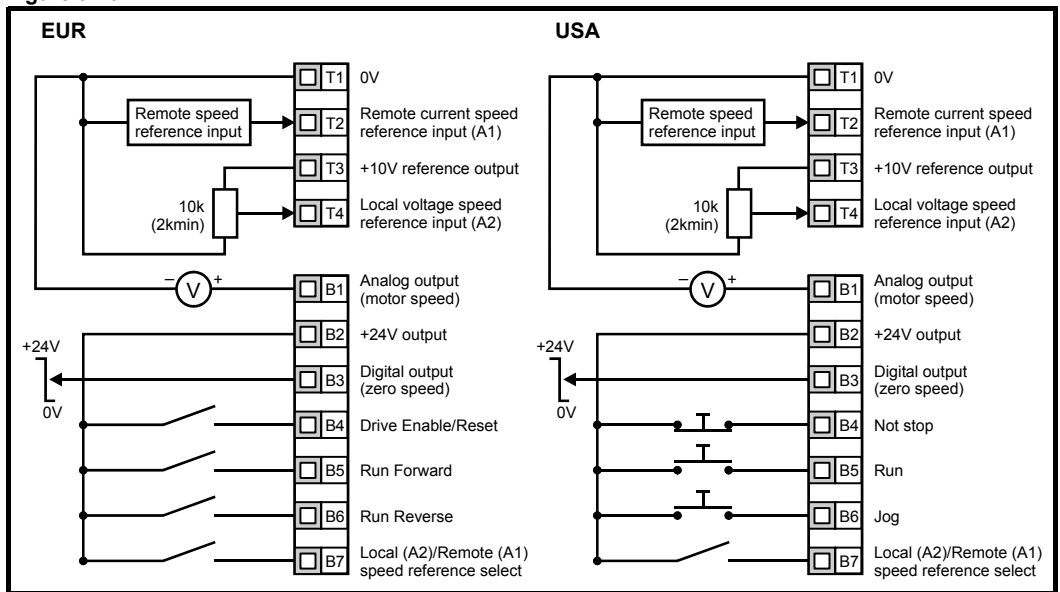
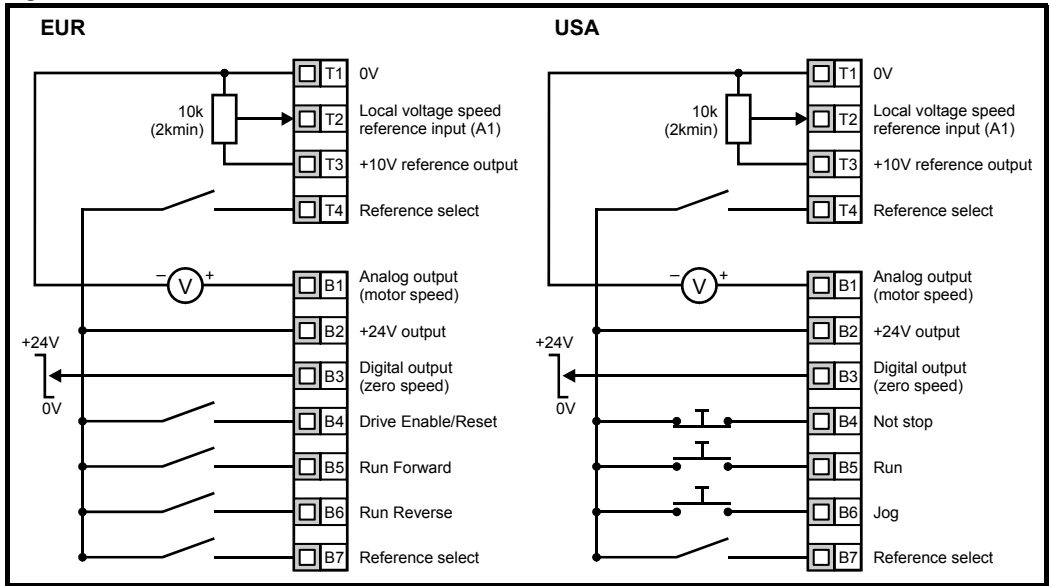

Figure 9-26 Pr 11.27 = AI.AV



Terminal B7 open: Local voltage speed reference input (A2) selected.
 Terminal B7 closed: Remote current speed reference input (A1) selected.

Figure 9-27 Pr 11.27 = AV.Pr



T4	B7	Reference selected
0	0	A1
0	1	Preset 2
1	0	Preset 3
1	1	Preset 4

Figure 9-28 Pr 11.27 = AI.Pr

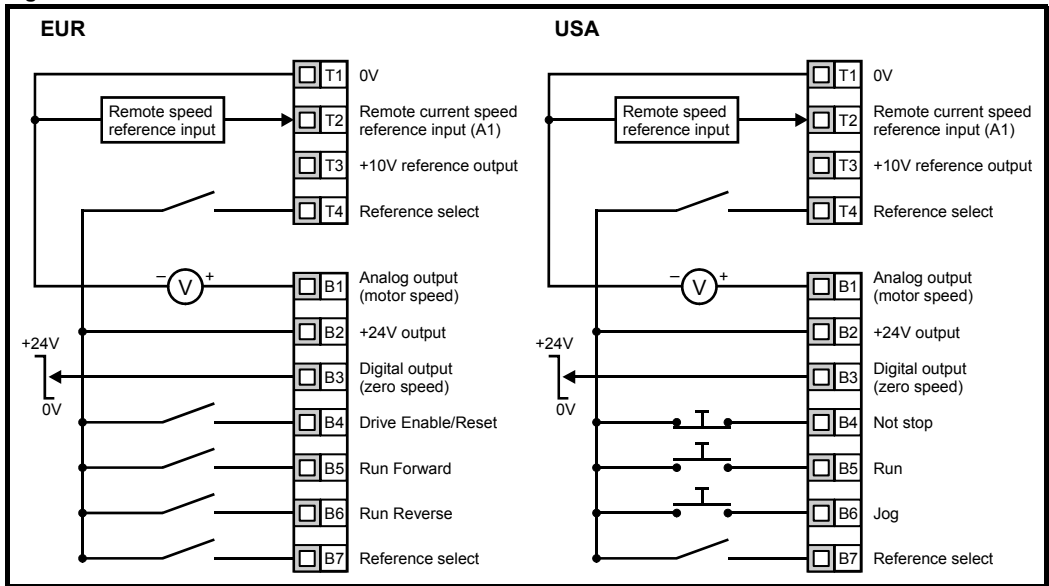

T4	B7	Reference selected
0	0	A1
0	1	Preset 2
1	0	Preset 3
1	1	Preset 4

Figure 9-29 Pr 11.27 = Pr

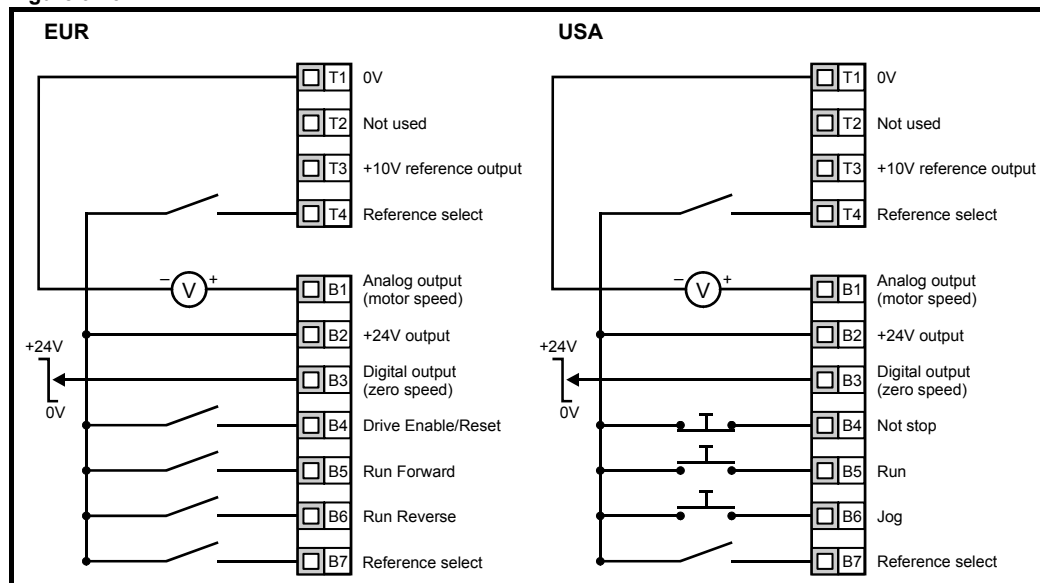

T4	B7	Reference selected
0	0	Preset 1
0	1	Preset 2
1	0	Preset 3
1	1	Preset 4

Figure 9-30 Pr 11.27 = PAd

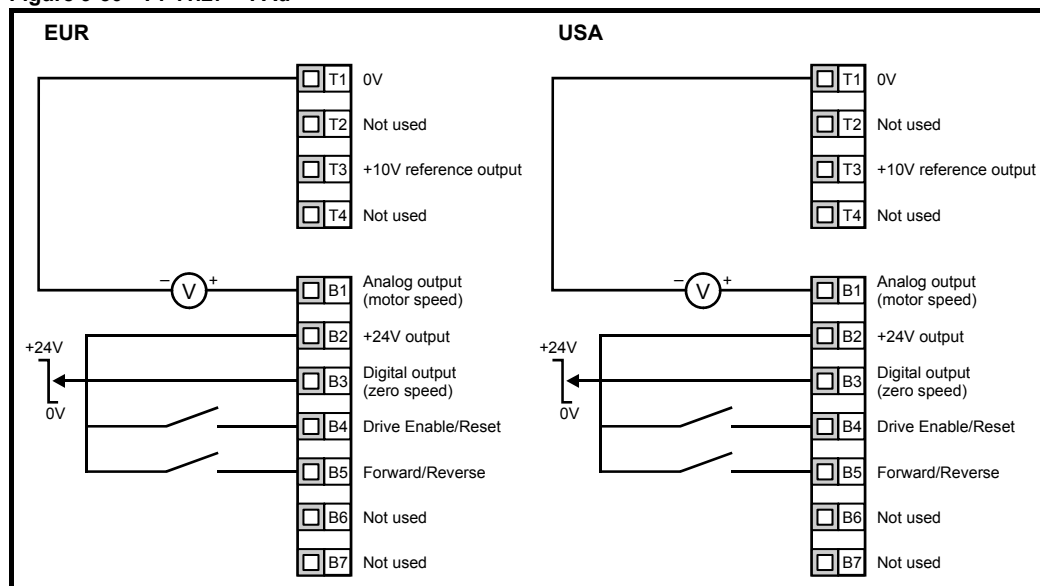

Setting-up a Forward/Reverse terminal in Keypad mode

From the drive's display:

- Set Pr 71 to 8.23
- Set Pr 61 to 6.33
- Press the Stop/Reset key

Terminal B5 will now be set-up as a Forward/Reverse terminal

Figure 9-31 Pr 11.27 = E.Pot

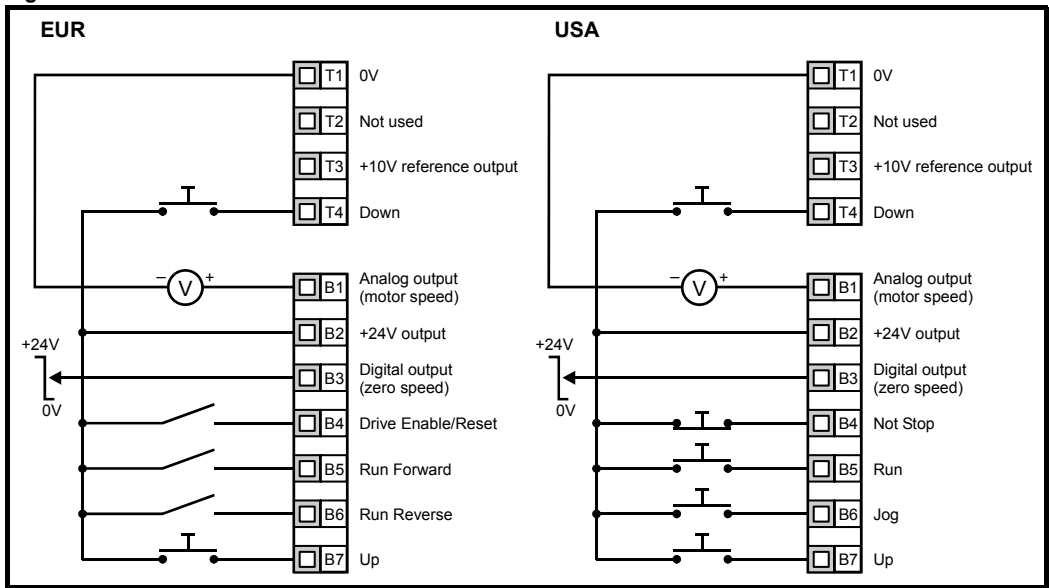

When Pr 11.27 is set to E.Pot, the following parameters are made available for adjustment:

- Pr 9.23: Motorised pot up/down rate (s/100%)
- Pr 9.22: Motorised pot bipolar select (0 = unipolar, 1 = bipolar)
- Pr 9.21: Motorised pot mode:
 - 0 = zero at power-up
 - 1 = last value at power-up
 - 2 = zero at power-up and only change when drive is running
 - 3 = last value at power-up and only change when drive is running

Figure 9-32 Pr 11.27 = tor

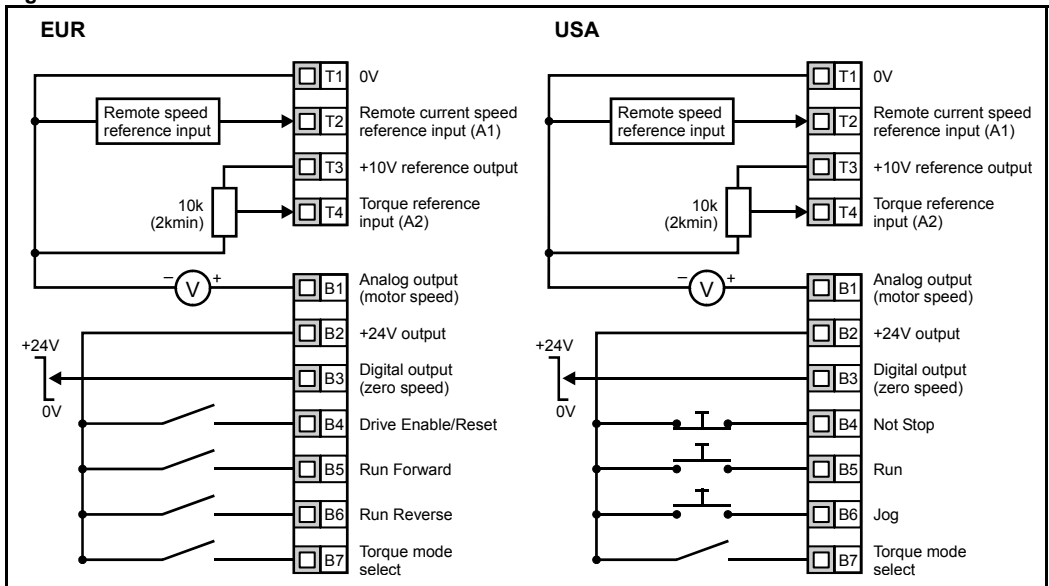

When torque mode is selected and the drive is connected to an unloaded motor, the motor speed may increase rapidly to the maximum speed (Pr 02 +20%)

WARNING

Figure 9-33 Pr 11.27 = Pid

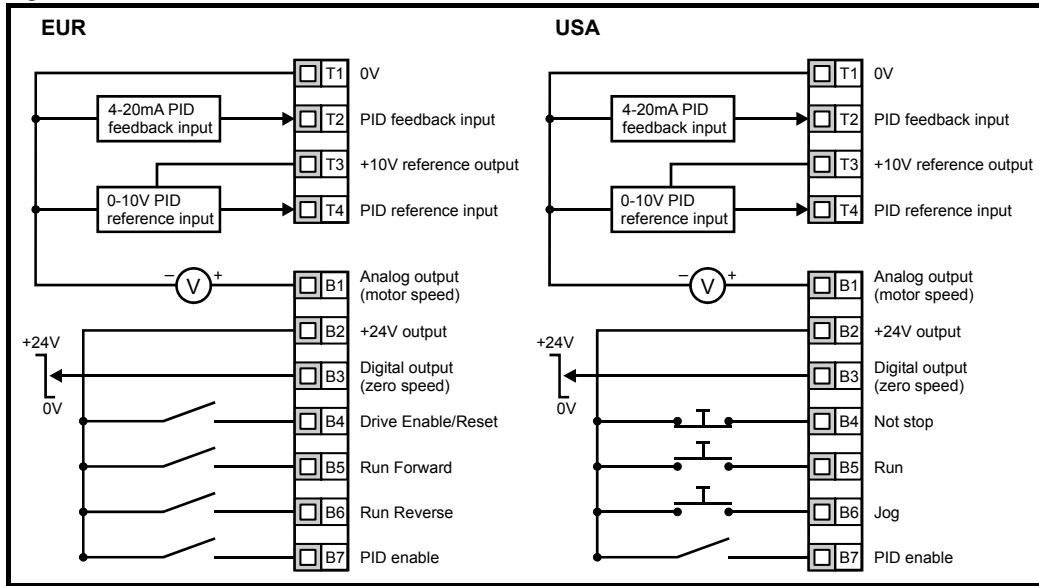

When Pr 11.27 is set to Pid, the following parameters are made available for adjustment:

- Pr 14.10: PID proportional gain
- Pr 14.11: PID integral gain
- Pr 14.06: PID feedback invert
- Pr 14.13: PID high limit (%)
- Pr 14.14: PID low limit (%)
- Pr 14.01: PID output (%)

Figure 9-34 PID logic diagram

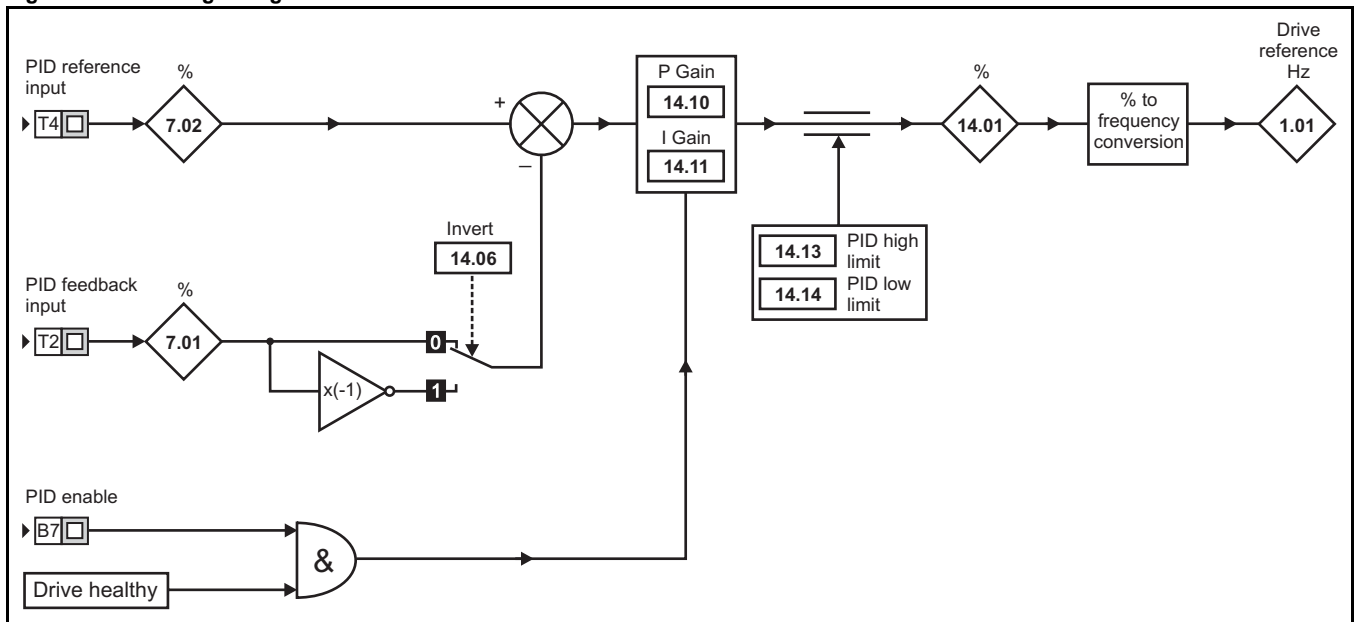
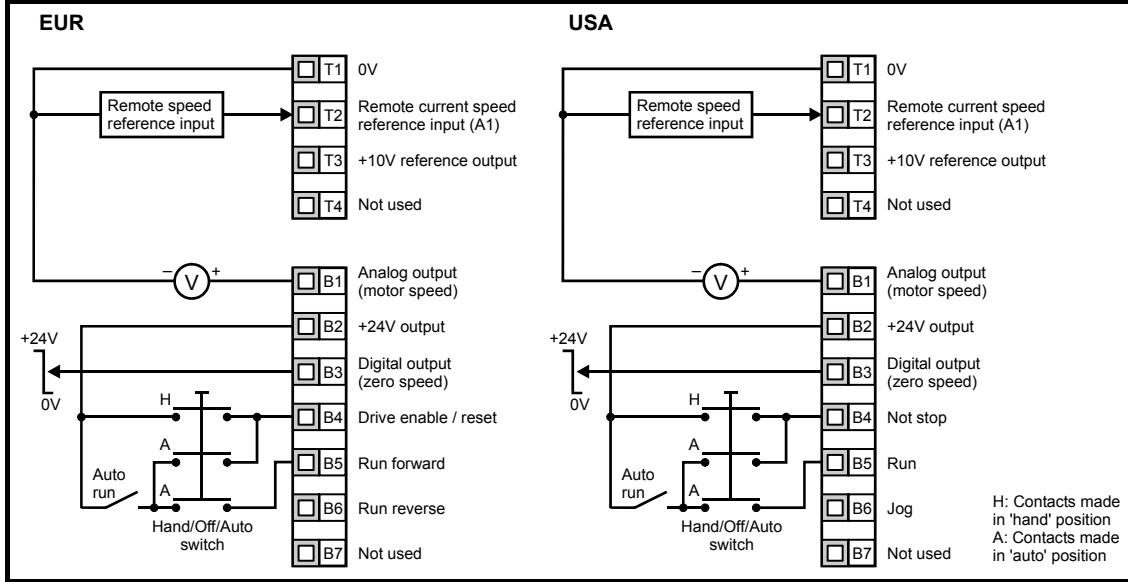

Figure 9-35 Pr 11.27 = HUAC



11.28 Unused parameter

11.29 Software version																
Coding	Bit	SP	FI	DE	Txt	VM	DP	ND	RA	NC	NV	PT	US	RW	BU	PS
Range	0.00 to 99.99															
Update rate	N/A															

The drive software version consists of three numbers xx.yy.zz. xx.yy is displayed in this parameter and zz is displayed in Pr 11.34. Where xx specifies a change that affects hardware compatibility, yy specifies a change that affects product documentation, and zz specifies a change that does not affect the product documentation.

11.30 User security code																
Coding	Bit	SP	FI	DE	Txt	VM	DP	ND	RA	NC	NV	PT	US	RW	BU	PS
Range	0 to 999															
Default	0															
Update rate	Background															

If any number, other than 0 is programmed into this parameter the user security is applied so that no parameters except Pr 11.44 can be adjusted with the LED keypad. When this parameter is read via an LED keypad and security is locked it appears as zero. The security code can be modified via serial comms etc. by setting this parameter to the required value, setting Pr 11.44 to 3 and initiating a reset by setting Pr 10.38 to 100. However security can only be cleared via the LED keypad.

11.31 Unused parameter

11.32 Maximum heavy duty drive current rating																
Coding	Bit	SP	FI	DE	Txt	VM	DP	ND	RA	NC	NV	PT	US	RW	BU	PS
Range	0.00 to 290.00 A															
Update rate	N/A															

This parameter indicates the continuous industrial current rating of the drive for heavy-duty operation. If this parameter is programmed into the level two area, the decimal place on the drives four digit display will be adjusted to 1 for drive sizes with current ratings greater than 99.99A.

11.33	Voltage rating																																
Coding	<table border="1" style="width:100%; border-collapse: collapse;"> <tr> <td>Bit</td><td>SP</td><td>FI</td><td>DE</td><td>Txt</td><td>VM</td><td>DP</td><td>ND</td><td>RA</td><td>NC</td><td>NV</td><td>PT</td><td>US</td><td>RW</td><td>BU</td><td>PS</td> </tr> <tr> <td></td><td></td><td></td><td></td><td>1</td><td></td><td></td><td>1</td><td></td><td>1</td><td></td><td>1</td><td></td><td></td><td>1</td><td></td> </tr> </table>	Bit	SP	FI	DE	Txt	VM	DP	ND	RA	NC	NV	PT	US	RW	BU	PS					1			1		1		1			1	
Bit	SP	FI	DE	Txt	VM	DP	ND	RA	NC	NV	PT	US	RW	BU	PS																		
				1			1		1		1			1																			
Range	0 (200), 1 (400)																																
Update rate	N/A																																

This parameter has two possible values and indicates the voltage rating of the drive.

- 0: 200 200V product
- 1: 400 400V product

11.34	Software sub-version																																
Coding	<table border="1" style="width:100%; border-collapse: collapse;"> <tr> <td>Bit</td><td>SP</td><td>FI</td><td>DE</td><td>Txt</td><td>VM</td><td>DP</td><td>ND</td><td>RA</td><td>NC</td><td>NV</td><td>PT</td><td>US</td><td>RW</td><td>BU</td><td>PS</td> </tr> <tr> <td></td><td></td><td></td><td></td><td></td><td></td><td></td><td>1</td><td></td><td>1</td><td></td><td>1</td><td></td><td></td><td>1</td><td></td> </tr> </table>	Bit	SP	FI	DE	Txt	VM	DP	ND	RA	NC	NV	PT	US	RW	BU	PS								1		1		1			1	
Bit	SP	FI	DE	Txt	VM	DP	ND	RA	NC	NV	PT	US	RW	BU	PS																		
							1		1		1			1																			
Range	0 to 99																																
Update rate	N/A																																

See Pr 11.29 on page 122.

11.35	DSP software version																																
Coding	<table border="1" style="width:100%; border-collapse: collapse;"> <tr> <td>Bit</td><td>SP</td><td>FI</td><td>DE</td><td>Txt</td><td>VM</td><td>DP</td><td>ND</td><td>RA</td><td>NC</td><td>NV</td><td>PT</td><td>US</td><td>RW</td><td>BU</td><td>PS</td> </tr> <tr> <td></td><td></td><td></td><td></td><td></td><td></td><td>1</td><td>1</td><td></td><td>1</td><td></td><td>1</td><td></td><td></td><td>1</td><td></td> </tr> </table>	Bit	SP	FI	DE	Txt	VM	DP	ND	RA	NC	NV	PT	US	RW	BU	PS							1	1		1		1			1	
Bit	SP	FI	DE	Txt	VM	DP	ND	RA	NC	NV	PT	US	RW	BU	PS																		
						1	1		1		1			1																			
Range	0.0 to 9.9																																
Update rate	N/A																																

This parameter indicates the version of DSP software fitted.

11.36 to 11.40	Unused parameters
-----------------------	--------------------------

11.41	Status mode timeout																																
Coding	<table border="1" style="width:100%; border-collapse: collapse;"> <tr> <td>Bit</td><td>SP</td><td>FI</td><td>DE</td><td>Txt</td><td>VM</td><td>DP</td><td>ND</td><td>RA</td><td>NC</td><td>NV</td><td>PT</td><td>US</td><td>RW</td><td>BU</td><td>PS</td> </tr> <tr> <td></td><td></td><td></td><td></td><td></td><td></td><td></td><td></td><td></td><td></td><td></td><td></td><td>1</td><td>1</td><td>1</td><td></td> </tr> </table>	Bit	SP	FI	DE	Txt	VM	DP	ND	RA	NC	NV	PT	US	RW	BU	PS													1	1	1	
Bit	SP	FI	DE	Txt	VM	DP	ND	RA	NC	NV	PT	US	RW	BU	PS																		
												1	1	1																			
Range	0 to 250 s																																
Default	240																																
Update rate	Background																																

This parameter sets the timeout in seconds for the drive display to revert to status mode from edit mode following no presses of the keypad. Although this parameter can be set to less than 2s, the minimum timeout is 2s.

11.42	Parameter cloning																																
Coding	<table border="1" style="width:100%; border-collapse: collapse;"> <tr> <td>Bit</td><td>SP</td><td>FI</td><td>DE</td><td>Txt</td><td>VM</td><td>DP</td><td>ND</td><td>RA</td><td>NC</td><td>NV</td><td>PT</td><td>US</td><td>RW</td><td>BU</td><td>PS</td> </tr> <tr> <td></td><td></td><td></td><td></td><td>1</td><td></td><td></td><td></td><td></td><td>1</td><td></td><td></td><td></td><td>1</td><td>1</td><td></td> </tr> </table>	Bit	SP	FI	DE	Txt	VM	DP	ND	RA	NC	NV	PT	US	RW	BU	PS					1					1				1	1	
Bit	SP	FI	DE	Txt	VM	DP	ND	RA	NC	NV	PT	US	RW	BU	PS																		
				1					1				1	1																			
Range	0 (no), 1 (rEAd), 2 (Prog), 3 (boot)																																
Default	0 (no)																																
Update rate	Actioned on exit of edit mode and on drive reset																																

NOTE

The SmartStick should only be installed and removed when power to the drive has been turned off.

This parameter selects the mode of operation for the cloning module. 4 options are available

Value	Display	Function
0	no	No action
1	rEAd	Read parameters from the SmartStick
2	Prog	Write parameters to the SmartStick
3	boot	Set the SmartStick as master, so it becomes read only.

When data is programmed to the SmartStick it takes the information directly from the drives EEPROM memory thus taking a copy of the stored configuration of the drive rather than the current configuration in drive RAM. The drive takes action on the command when the user exits the parameter edit mode. Also, to be backwards compatible with Commander SE and to allow cloning over the serial interface, the drive will action the value programmed on a drive reset.

1 rEAd

Parameters can only be read from the SmartStick when the drive is disabled or tripped. If the drive is not in one of these states when a read is commanded, the display will flash **FAIL** twice and then Pr 11.42 will be set back to no. Immediately after a read takes place, Pr 11.42 is set back to no by the drive. Once parameters are read from the SmartStick the drive automatically performs a parameter save to its internal EEPROM.

2 Prog

Parameters can be written to the SmartStick at any time. When a 'Prog' is commanded, the SmartStick is updated with the current parameter set. Pr 11.42 is set back to no prior to the write taking place. If the card is read only the display will flash **FAIL** twice and then Pr 11.42 will be set back to no.

3 boot

Mode 3 is similar to mode 2 except that Pr 11.42 is not reset to 0 before the write takes place. If the 'boot' mode is stored in the cloning card this makes the cloning the master device. When a drive is powered up it always checks for a SmartStick, if one is fitted and it has been programmed in 'boot' mode the parameters are automatically loaded from the cloning card to the drive and furthermore they are saved in the drive. This provides a very fast and efficient way of re-programming a number of drives. Once a card is set to boot it becomes read only. If the card is read only the display will flash **FAIL** twice and then Pr 11.42 will be set back to no.

Different drive ratings

The SmartStick can be used to copy parameters between drives with different ratings but certain rating dependant parameters are not copied to the cloned drive, but are still stored within the cloning key.

If the data is transferred to a drive of a different voltage or current rating from the source drive all parameters with the RA coding bit set are not modified and a **C.rtg** trip occurs.

Parameter number	Function
2.08	Standard ramp voltage
4.07, 21.29	Current limits
5.07, 21.07	Motor rated currents
5.09, 21.09	Motor rated voltages
5.17, 21.12	Stator resistances
5.18	Switching frequency
5.23, 21.13	Voltage offsets
5.24, 21.14	Transient inductances
6.06	DC injection braking current

NOTE

Modes 1 and 2 are not saved to EEPROM or to the cloning card.

11.43	Load defaults															
Coding	Bit	SP	FI	DE	Txt	VM	DP	ND	RA	NC	NV	PT	US	RW	BU	PS
					1					1				1	1	
Range	0 (no), 1 (Eur), 2 (USA)															
Default	0 (no)															
Update rate	Actioned on exit of edit mode and on drive reset															

If this parameter is set to a non-zero value and the drive is reset when the drive is inactive, the selected default parameters will automatically be loaded. After the parameters have been set to default values they are automatically saved to the drive's internal EEPROM. If the drive is active the display will flash **FAIL** twice and then Pr 11.43 will be set back to no.

Value	Display	Function
0	no	No action
1	Eur	Load European defaults
2	USA	Load USA defaults

11.44	Security status															
Coding	Bit	SP	FI	DE	Txt	VM	DP	ND	RA	NC	NV	PT	US	RW	BU	PS
					1			1				1	1	1	1	
Range	0 (L1), 1 (L2), 2 (L3), 3 (Loc)															
Default	0 (L1)															
Update rate	Actioned on exit of edit mode and on drive reset															

This read write parameter defines the level of security for menu 0.

9.12.1 User programming (PLC ladder logic programming)

11.47	Drive user program enable															
Coding	Bit	SP	FI	DE	Txt	VM	DP	ND	RA	NC	NV	PT	US	RW	BU	PS
													1	1	1	
Range	0 to 2															
Default	0															
Update rate	Background read															

The drive user program enable parameter is used to start and stop the drive user program.

Value	Description
0	Stop the drive user program
1	Run the drive user program (trip drive if LogicStick is not fitted). Any out-of-range parameter writes attempted will be limited to the maximum / minimum values valid for that parameter before being written.
2	Run the drive user program (trip drive if LogicStick is not fitted). Any out-of-range parameter writes attempted will cause a drive trip.

11.48	Drive user program status															
Coding	Bit	SP	FI	DE	Txt	VM	DP	ND	RA	NC	NV	PT	US	RW	BU	PS
								1		1		1				
Range	-128 to +127															
Update rate	Background write															

The drive user program status parameter indicates to the user the actual state of the drive user program. (not fitted / running / stopped / tripped.)

Value	Description
-n	User program caused a drive trip due to an error condition while running rung n. Note that the rung number is shown on the display as a negative number.
0	User program is not fitted.
1	User program is fitted but stopped.
2	User program is fitted and running.

11.49	Unused parameter
--------------	-------------------------

11.50	User program maximum scan time															
Coding	Bit	SP	FI	DE	Txt	VM	DP	ND	RA	NC	NV	PT	US	RW	BU	PS
								1		1		1			1	
Range	0 to 65535 ms															
Update rate	User program execution period															

The user program maximum scan time parameter gives the longest scan time within the last ten scans of the drive user program. If the scan time is greater than the maximum value which may be represented by this parameter the value will be clipped to the maximum value.

9.13 Menu 12: Programmable threshold and variable selector

Table 9-18 Menu 12 parameters: single line descriptions

Parameter	Range	Default	Setting	Update Rate
12.01	Threshold detector 1 output	0 or 1		21 ms
12.02	Threshold detector 2 output	0 or 1		21 ms
12.03	Threshold detector 1 source	Pr 0.01 to Pr 21.51	Pr 0.00	Drive reset
12.04	Threshold detector 1 level	0.0 to 100.0%	0.0	21 ms
12.05	Threshold detector 1 hysteresis	0.0 to 25.0%	0.0	21 ms
12.06	Threshold detector 1 output invert	0 or 1	0	21 ms
12.07	Threshold detector 1 destination	Pr 1.01 to Pr 21.51	Pr 0.00	Drive reset
12.08	Variable selector 1 source 1	Pr 0.01 to Pr 21.51	Pr 0.00	Drive reset
12.09	Variable selector 1 source 2	Pr 0.01 to Pr 21.51	Pr 0.00	Drive reset
12.10	Variable selector 1 mode	0 to 9	0	21 ms
12.11	Variable selector 1 destination	Pr 1.01 to Pr 21.51	Pr 0.00	Drive reset
12.12	Variable selector 1 output	±100.0%		21 ms
12.13	Variable selector 1 source 1 scaling	±4.000	1.000	21 ms
12.14	Variable selector 1 source 2 scaling	±4.000	1.000	21 ms
12.15	Variable selector 1 control	0.00 to 99.99	0.00	B
12.16	Not used			
12.17	Not used			
12.18	Not used			
12.19	Not used			
12.20	Not used			
12.21	Not used			
12.22	Not used			
12.23	Threshold detector 2 source	Pr 0.01 to Pr 21.51	Pr 0.00	Drive reset
12.24	Threshold detector 2 level	0.0 to 100.0%	0.0	21 ms
12.25	Threshold detector 2 hysteresis	0.0 to 25.0%	0.0	21 ms
12.26	Threshold detector 2 output invert	0 or 1	0	21 ms
12.27	Threshold detector 2 destination	Pr 1.01 to Pr 21.51	Pr 0.00	Drive reset
12.28	Variable selector 2 source 1	Pr 0.01 to Pr 21.51	Pr 0.00	Drive reset
12.29	Variable selector 2 source 2	Pr 0.01 to Pr 21.51	Pr 0.00	Drive reset
12.30	Variable selector 2 mode	0 to 9	0	21 ms
12.31	Variable selector 2 destination	Pr 1.01 to Pr 21.51	Pr 0.00	Drive reset
12.32	Variable selector 2 output	±100.0%		21 ms
12.33	Variable selector 2 source 1 scaling	±4.000	1.000	21 ms
12.34	Variable selector 2 source 2 scaling	±4.000	1.000	21 ms
12.35	Variable selector 2 control	0.00 to 99.99	0.00	B
12.36	Not used			
12.37	Not used			
12.38	Not used			
12.39	Not used			
12.40	Brake release indicator	0 or 1		21 ms
12.41	Brake controller enable {12}	0 to 3	0	Drive reset
12.42	Brake release current threshold {46}	0 to 200%	50%	21 ms
12.43	Brake apply current threshold {47}	0 to 200%	10%	21 ms
12.44	Brake release frequency {48}	0.0 to 20.0 Hz	1	21 ms
12.45	Brake apply frequency {49}	0.0 to 20.0 Hz	2	21 ms
12.46	Pre-brake release delay {50}	0.0 to 25.0 s	1.0	21 ms
12.47	Post-brake release delay {51}	0.0 to 25.0 s	1.0	21 ms

Figure 9-36 Menu 12A logic diagram

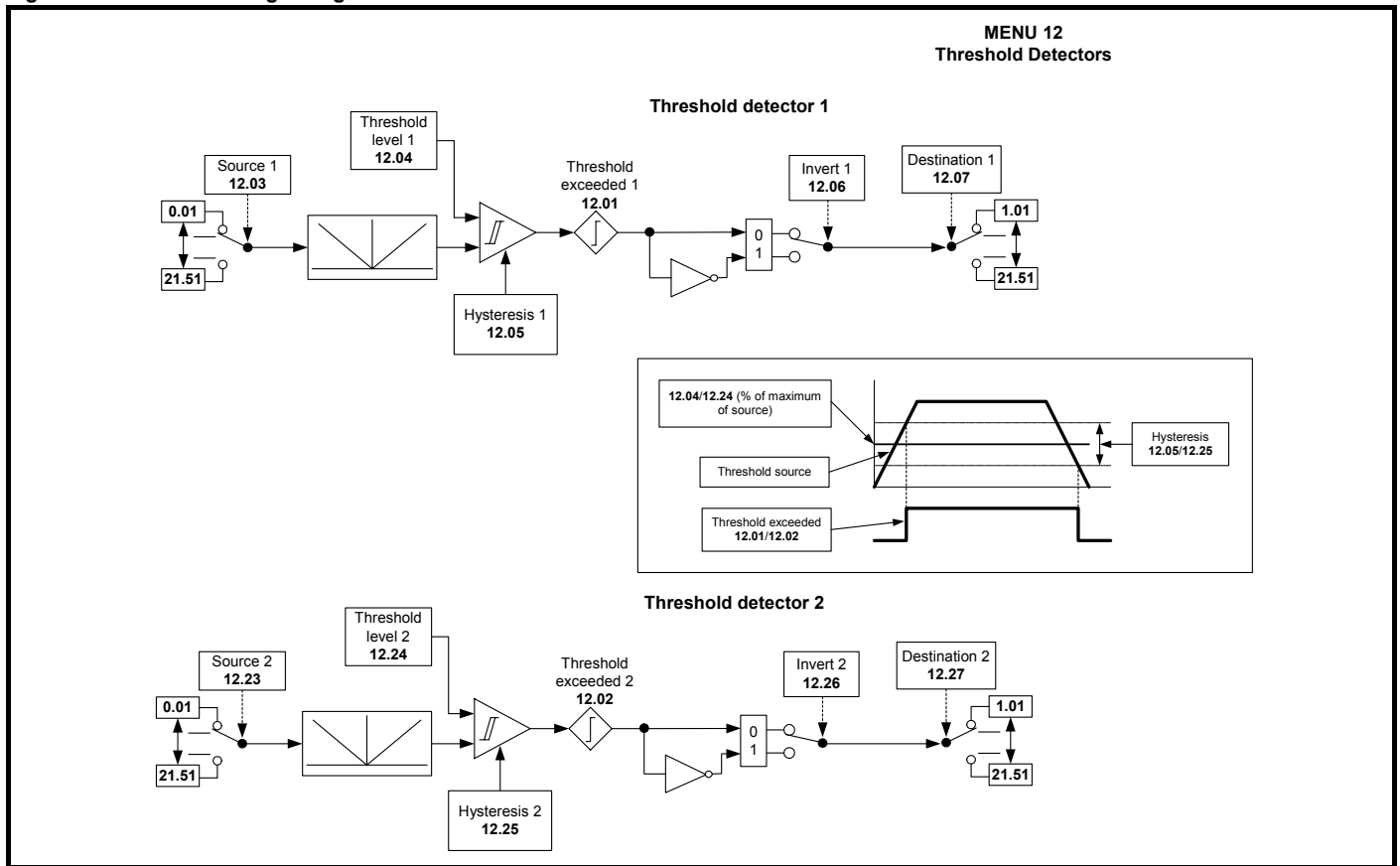

Figure 9-37 Menu 12B logic diagram

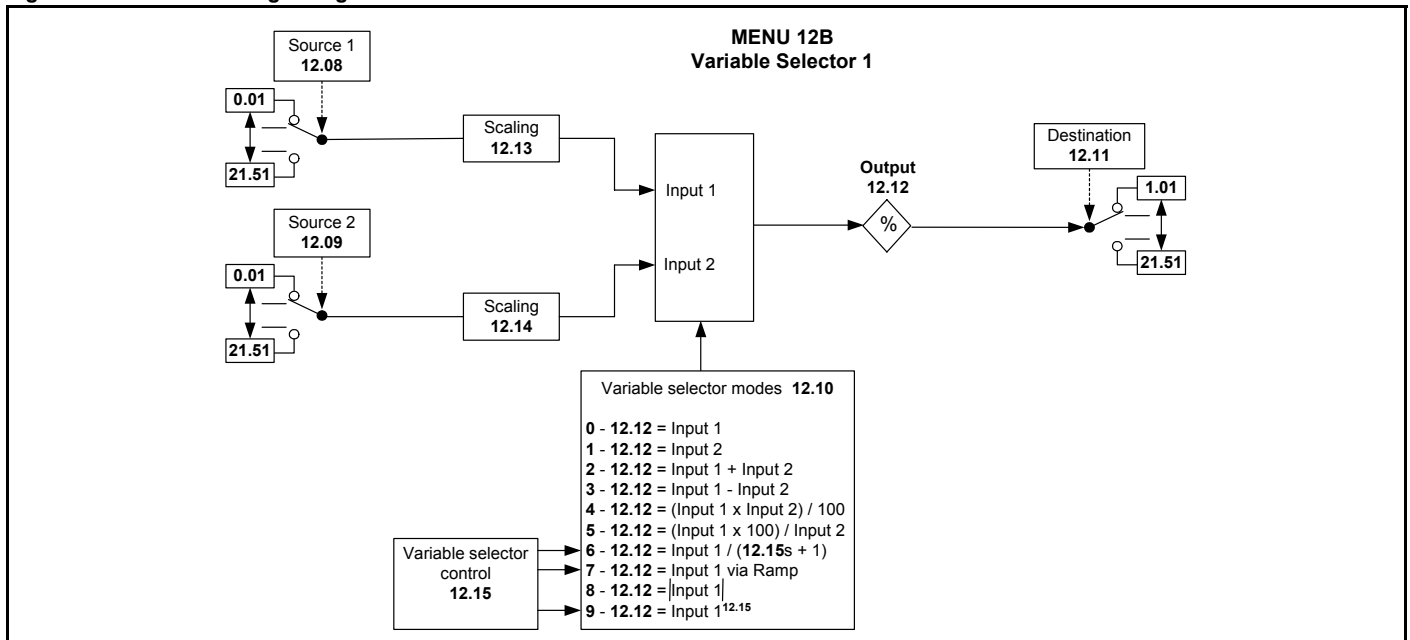

Figure 9-38 Menu 12C logic diagram

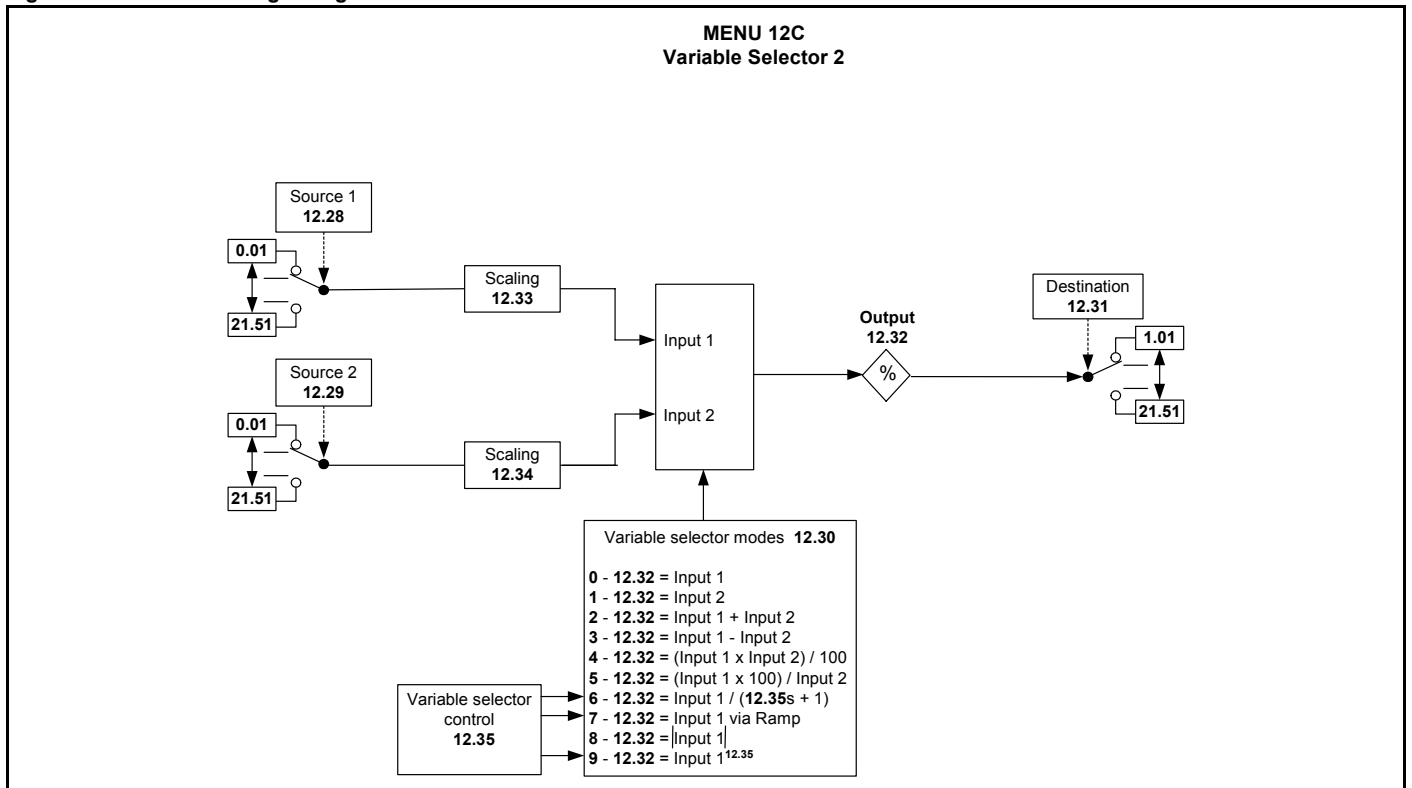
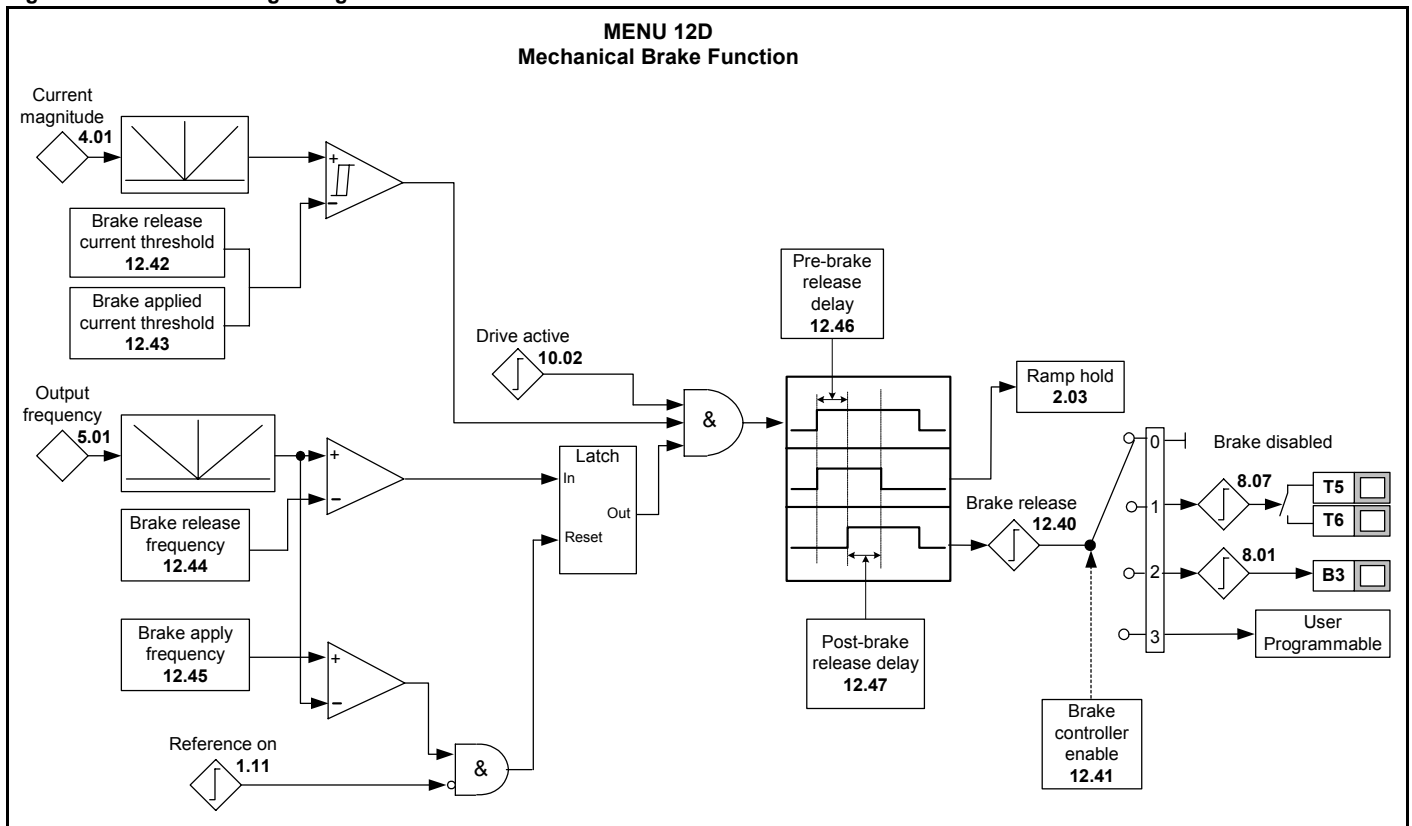

Figure 9-39 Menu 12D logic diagram



Menu 12 includes two threshold detectors which produce logic signals depending on the level of a variable value with respect to a threshold, and two variable selectors which allow two input parameters to be selected or combined to produce a variable output. A function is active if one or more sources are routed to a valid parameter.

12.01	Threshold detector 1 output indicator															
12.02	Threshold detector 2 output indicator															
Coding	Bit	SP	FI	DE	Txt	VM	DP	ND	RA	NC	NV	PT	US	RW	BU	PS
	1							1		1		1				
Range	0 or 1															
Update rate	21 ms															

These parameters indicate whether the threshold input variable is above (1) or below (0) the programmed threshold.

12.03	Threshold detector 1 source															
Coding	Bit	SP	FI	DE	Txt	VM	DP	ND	RA	NC	NV	PT	US	RW	BU	PS
	1							1		1		1				
Range	Pr 0.01 to Pr 21.51															
Update rate	Read on drive reset															

This parameter and Pr 12.23 define the parameter to be input to the programmable threshold.

The absolute value of the source variable is taken as input to the threshold comparator. Only non-bit parameters can be programmed as a source. If a non valid parameter is programmed the input value is taken as 0.

12.04	Threshold detector 1 level															
Coding	Bit	SP	FI	DE	Txt	VM	DP	ND	RA	NC	NV	PT	US	RW	BU	PS
							1						1	1	1	
Range	0.0 to 100.0 %															
Update rate	21 ms															

This parameter and Pr 12.24 are the user defined threshold levels entered as a percentage of the source maximum.

12.05	Threshold detector 1 hysteresis															
Coding	Bit	SP	FI	DE	Txt	VM	DP	ND	RA	NC	NV	PT	US	RW	BU	PS
							1						1	1	1	
Range	0.0 to 25.0 %															
Default	0.0															
Update rate	21 ms															

This parameter and Pr 12.25 define the band within which no change will occur on the output.

The upper limit for switching is: Level + Hysteresis/2

The lower limit for switching is: Level - Hysteresis/2

12.06	Threshold detector 1 output invert															
Coding	Bit	SP	FI	DE	Txt	VM	DP	ND	RA	NC	NV	PT	US	RW	BU	PS
	1												1	1		
Range	0 or 1															
Default	0															
Update rate	21 ms															

This parameter and Pr 12.26 are used to invert the logic states of the threshold output if required.

12.07	Threshold detector 1 destination															
Coding	Bit	SP	FI	DE	Txt	VM	DP	ND	RA	NC	NV	PT	US	RW	BU	PS
				1			2					1	1	1	1	
Range	Pr 1.01 to Pr 21.51															
Default	Pr 0.00															
Update rate	Read on drive reset															

This parameter and Pr 12.27 define the parameter which is to be controlled by the threshold parameter. Only bit parameters which are not protected can be set up as a destination. If a non valid parameter is programmed the output is not routed anywhere.

12.08	Variable selector 1 source 1															
12.09	Variable selector 1 source 2															
Coding	Bit	SP	FI	DE	Txt	VM	DP	ND	RA	NC	NV	PT	US	RW	BU	PS
							2					1	1	1	1	
Range	Pr 0.01 to Pr 21.51															
Default	Pr 0.00															
Update rate	Read on drive reset															

These parameters and Pr 12.28 and Pr 12.29 define the parameters which are to be switched by the variable selector block. These can bit variables or non bit variables but not a mixture of both. Also the output parameter programmed must be the same type as the destination parameter, if not they will always read as zero. When programming a reference to a variable source select, if the reference is a percentage, then the variable source treats the percentage as a whole number, e.g. 50.0% of reference = 50.0Hz.

12.10	Variable selector 1 mode															
Coding	Bit	SP	FI	DE	Txt	VM	DP	ND	RA	NC	NV	PT	US	RW	BU	PS
													1	1	1	
Range	0 to 9															
Default	0															
Update rate	21 ms															

The output of the variable select can be changed by the mode as in the following table:

Mode value (Pr 12.30)	Action	Result
0	Select input 1	output = input1
1	Select input 2	output = input2
2	Add	output = input1 + input2
3	Subtract	output = input1 - input2
4	Multiply	output = (input1 x input2) / 100.0
5	Divide	output = (input1 x 100.0) / input2
6	Time constant	output = input1 / ((control param)s + 1)
7	Linear ramp	output = input1 via a ramp with a ramp time of (control param) seconds from 0 to 100%
8	Modulus	output = input1
9	Raise to power	output = input control param (1 - 3) output = 0.02: output = input ² / 100 output = 0.02: output = input ³ / 100 ² control has any other value: output = input 1

12.11	Variable selector 1 destination															
Coding	Bit	SP	FI	DE	Txt	VM	DP	ND	RA	NC	NV	PT	US	RW	BU	PS
			1				2					1	1	1	1	
Range	Pr 1.01 to Pr 21.51															
Default	Pr 0.00															
Update rate	Read on drive reset															

Defines the destination parameters for the variable selector outputs. Only non-protected parameters can be programmed as a destination. If a non-valid parameter is programmed, the output is not routed anywhere.

12.12	Variable selector 1 output															
Coding	Bit	SP	FI	DE	Txt	VM	DP	ND	RA	NC	NV	PT	US	RW	BU	PS
							1	1		1		1				
Range	±100.0 %															
Update rate	21 ms															

Indicates the level of output signal from the variable selector.

12.13	Variable selector 1 source 1 scaling															
Coding	Bit	SP	FI	DE	Txt	VM	DP	ND	RA	NC	NV	PT	US	RW	BU	PS
							3						1	1		
Range	±4.000															
Default	1.000															
Update rate	21 ms															

Can be used to scale the source 1 inputs of the variable selectors.

12.14	Variable selector 1 source 2 scaling															
Coding	Bit	SP	FI	DE	Txt	VM	DP	ND	RA	NC	NV	PT	US	RW	BU	PS
							3						1	1		
Range	±4.000															
Default	1.000															
Update rate	21 ms															

Can be used to scale the source 2 inputs of the variable selectors.

12.15	Variable selector 1 control															
Coding	Bit	SP	FI	DE	Txt	VM	DP	ND	RA	NC	NV	PT	US	RW	BU	PS
							2						1	1	1	
Range	0.00 to 99.99															
Default	0.00															
Update rate	Background															

The control parameter can be used to input a value when modes 6, 7 and 9 of the variable selector are implemented. See Pr 12.10 on page 131 and Pr 12.30 on page 133 for variable selector modes.

12.16 to 12.22	Unused parameters
----------------	-------------------

12.23	Threshold detector 2 source															
Coding	Bit	SP	FI	DE	Txt	VM	DP	ND	RA	NC	NV	PT	US	RW	BU	PS
	1							1		1		1				
Range	0 or 1															
Update rate	Read on drive reset															

This parameter and Pr 12.03 define the parameter to be input to the programmable threshold.

The absolute value of the source variable is taken as input to the threshold comparator. Only non-bit parameters can be programmed as a source. If a non valid parameter is programmed the input value is taken as 0.

12.24	Threshold detector 2 level															
Coding	Bit	SP	FI	DE	Txt	VM	DP	ND	RA	NC	NV	PT	US	RW	BU	PS
							1						1	1	1	
Range	0.0 to 100.0 %															
Update rate	21 ms															

This parameter and Pr 12.04 are the user defined threshold levels entered as a percentage of the source maximum.

12.25	Threshold detector 2 hysteresis															
Coding	Bit	SP	FI	DE	Txt	VM	DP	ND	RA	NC	NV	PT	US	RW	BU	PS
							1						1	1	1	
Range	0.0 to 25.0 %															
Default	0.0															
Update rate	21 ms															

This parameter and Pr 12.05 define the band within which no change will occur on the output.

The upper limit for switching is: Level + Hysteresis/2

The lower limit for switching is: Level - Hysteresis/2

12.26	Threshold detector 2 output invert															
Coding	Bit	SP	FI	DE	Txt	VM	DP	ND	RA	NC	NV	PT	US	RW	BU	PS
	1												1	1		
Range	0 or 1															
Default	0															
Update rate	21 ms															

This parameter and Pr 12.06 are used to invert the logic states of the threshold output if required.

12.27	Threshold detector 2 destination															
Coding	Bit	SP	FI	DE	Txt	VM	DP	ND	RA	NC	NV	PT	US	RW	BU	PS
				1			2					1	1	1	1	
Range	Pr 1.01 to Pr 21.51															
Default	Pr 0.00															
Update rate	Read on drive reset															

This parameter and Pr 12.07 define the parameter which is to be controlled by the threshold parameter. Only bit parameters which are not protected can be set up as a destination. If a non valid parameter is programmed the output is not routed anywhere.

12.28	Variable selector 2 source 1															
12.29	Variable selector 2 source 2															
Coding	Bit	SP	FI	DE	Txt	VM	DP	ND	RA	NC	NV	PT	US	RW	BU	PS
							2					1	1	1	1	
Range	Pr 0.01 to Pr 21.51															
Default	Pr 0.00															
Update rate	Read on drive reset															

These parameters and Pr 12.08 and Pr 12.09 define the parameters which are to be switched by the variable selector block. These can bit variables or non bit variables but not a mixture of both. Also the output parameter programmed must be the same type as the destination parameter, if not they will always read as zero. When programming a reference to a variable source select, if the reference is a percentage, then the variable source treats the percentage as a whole number, e.g. 50.0% of reference = 50.0Hz.

12.30	Variable selector 2 mode															
Coding	Bit	SP	FI	DE	Txt	VM	DP	ND	RA	NC	NV	PT	US	RW	BU	PS
													1	1	1	
Range	0 to 9															
Default	0															
Update rate	21 ms															

The output of the variable select can be changed by the mode as in the following table:

Mode value (Pr 12.30)	Action	Result
0	Select input 1	output = input1
1	Select input 2	output = input2
2	Add	output = input1 + input2
3	Subtract	output = input1 - input2
4	Multiply	output = (input1 x input2) / 100.0
5	Divide	output = (input1 x 100.0) / input2
6	Time constant	output = input1 / ((control param)s + 1)
7	Linear ramp	output = input1 via a ramp with a ramp time of (control param) seconds from 0 to 100%
8	Modulus	output = input1
9	Raise to power	output = input ^{control param} (1-3) output = 0.02: output = input ² / 100 output = 0.02: output = input ³ / 100 ² control has any other value: output = input 1

12.31	Variable selector 2 destination															
Coding	Bit	SP	FI	DE	Txt	VM	DP	ND	RA	NC	NV	PT	US	RW	BU	PS
				1			2					1	1	1	1	
Range	Pr 1.01 to Pr 21.51															
Default	Pr 0.00															
Update rate	Read on drive reset															

Defines the destination parameters for the variable selector outputs.

12.32	Variable selector 2 output															
Coding	Bit	SP	FI	DE	Txt	VM	DP	ND	RA	NC	NV	PT	US	RW	BU	PS
							1	1		1		1				
Range	±100.0 %															
Update rate	21 ms															

Indicates the level of output signal from the variable selector.

12.33	Variable selector 2 source 1 scaling															
Coding	Bit	SP	FI	DE	Txt	VM	DP	ND	RA	NC	NV	PT	US	RW	BU	PS
							3						1	1		
Range	±4.000															
Default	1.000															
Update rate	21 ms															

Can be used to scale the source 1 inputs of the variable selectors.

12.34	Variable selector 2 source 2 scaling															
Coding	Bit	SP	FI	DE	Txt	VM	DP	ND	RA	NC	NV	PT	US	RW	BU	PS
							3						1	1		
Range	±4.000															
Default	1.000															
Update rate	21 ms															

Can be used to scale the source 2 inputs of the variable selectors.

12.35	Variable selector 2 control															
Coding	Bit	SP	FI	DE	Txt	VM	DP	ND	RA	NC	NV	PT	US	RW	BU	PS
							2						1	1	1	
Range	0.00 to 99.99															
Default	0.00															
Update rate	Background															

The control parameter can be used to input a value when modes 6, 7 and 9 of the variable selector are implemented. See Pr 12.10 on page 131 and Pr 12.30 on page 133 for variable selector modes.

12.36 to 12.39	Unused parameters															
----------------	-------------------	--	--	--	--	--	--	--	--	--	--	--	--	--	--	--

9.13.1 Brake control function

The brake control function can be used to control an electro-mechanical brake via the drive digital I/O.

12.40	Brake release indicator															
Coding	Bit	SP	FI	DE	Txt	VM	DP	ND	RA	NC	NV	PT	US	RW	BU	PS
	1							1		1		1				
Range	0 or 1															
Update rate	21 ms															

This parameter should be used as a source for a digital output to control an electro-mechanical brake. This parameter is one to release the brake and zero to apply the brake. Digital I/O can be automatically configured to use this parameter as a source (see Pr 12.41).

12.41	Brake controller															
Coding	Bit	SP	FI	DE	Txt	VM	DP	ND	RA	NC	NV	PT	US	RW	BU	PS
					1								1	1	1	
Range	0 to 3															
Default	0															
Update rate	Actioned on exit of edit mode and on drive reset															

Action will only occur if the drive is inactive. If the drive is active the parameter will return to its pre altered value on exit from edit mode.

0 diS

The brake controller is disabled and no other drive parameters are affected by the brake controller. When this parameter is changed from a non-zero value to zero Pr 2.03 is set to zero.

1 rEL

The brake controller is enabled with I/O set up to control the brake via the relay output. Drive healthy is re-routed to digital I/O.

2 d IO

The brake controller is enabled with I/O set up to control the brake via digital I/O.

3 USEr

The brake controller is enabled, but no parameters are set to select the brake output.

The following table shows the automatic parameter changes that occur to set up digital I/O and the relay output after exit from edit mode or drive reset when Pr 12.41 has been changed.

Old value of Pr 12.41	New value of Pr 12.41	Pr 8.11	Pr 8.21	Pr 8.31	Pr 8.17	Pr 8.27	Pr 8.41
Any	1	Drive healthy output			Brake release output		3
		0	Pr 10.01	1	0	Pr 12.40	
Not 1	2	Brake release output					8
		0	Pr 12.40	1	No change	No change	
1	2	Brake release output			Drive healthy output		8
		0	Pr 12.40	1	0	Pr 10.01	
1	0 or 3	Zero speed output			Drive healthy output		0
		0	Pr 10.03	1	0	Pr 10.01	
2	0 or 3	Zero speed output					0
		0	Pr 10.03	1	No change	No change	

Figure 9-40 Brake function diagram

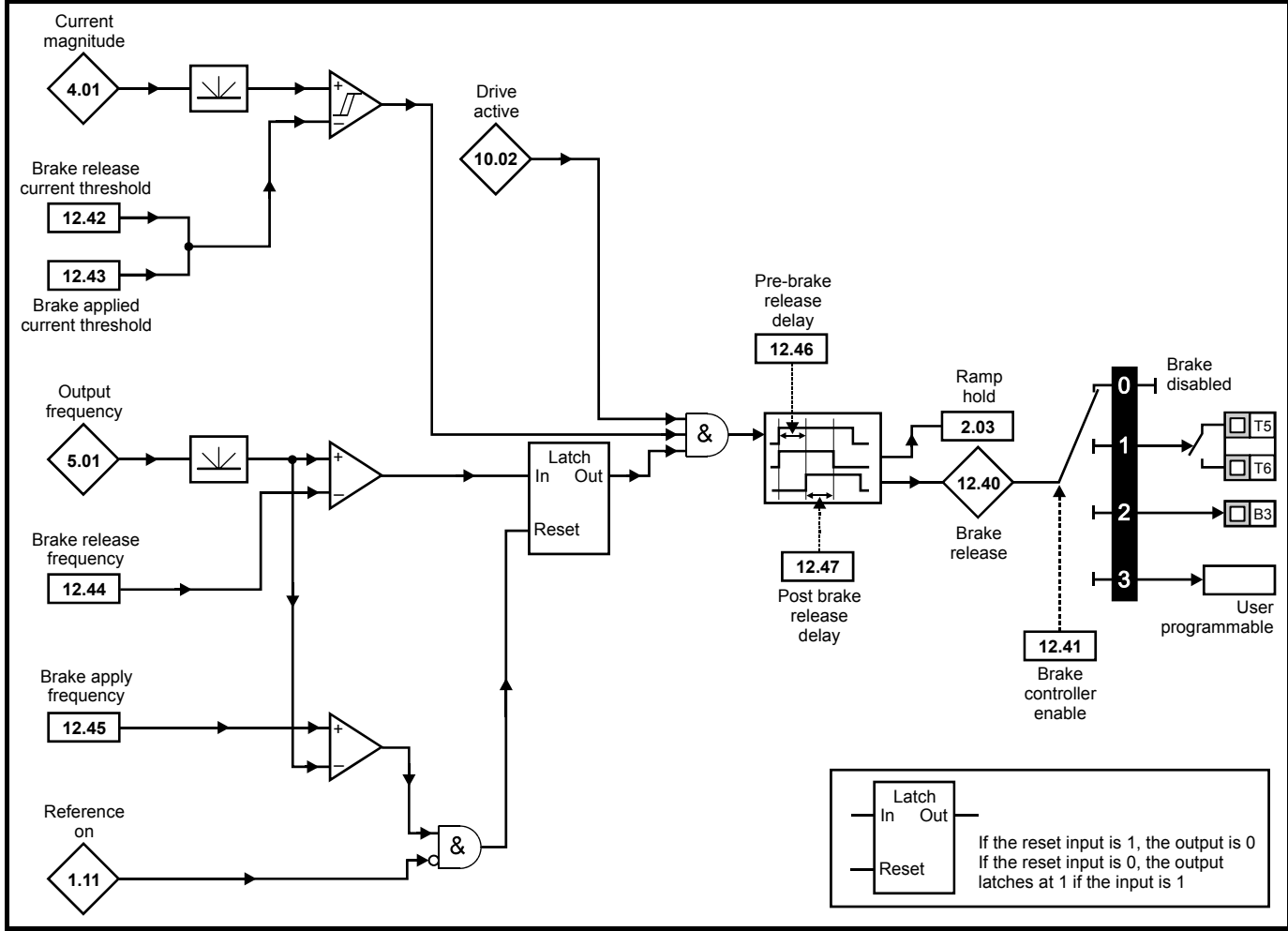
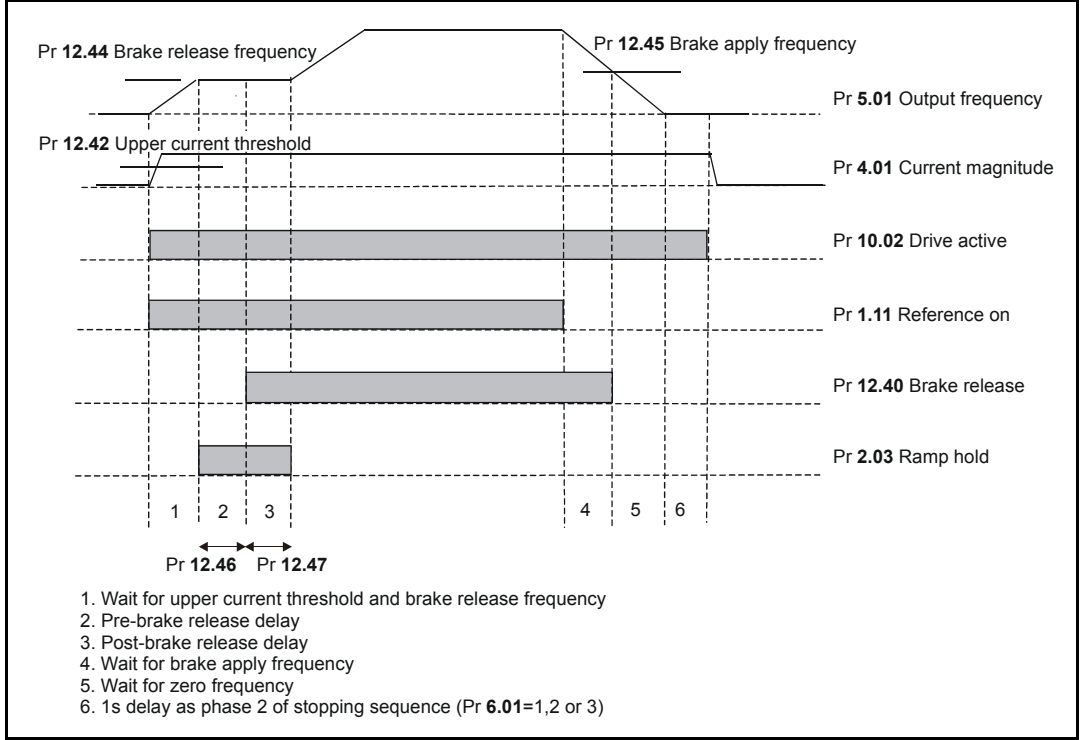

Figure 9-41 Brake sequence



12.42	Brake release current threshold															
Coding	Bit	SP	FI	DE	Txt	VM	DP	ND	RA	NC	NV	PT	US	RW	BU	PS
													1	1	1	
Range	0 to 200 %															
Default	50															
Update rate	21 ms															

12.43	Brake apply current threshold															
Coding	Bit	SP	FI	DE	Txt	VM	DP	ND	RA	NC	NV	PT	US	RW	BU	PS
													1	1	1	
Range	0 to 200 %															
Default	10															
Update rate	21 ms															

The current magnitude is compared to an upper and lower threshold by a comparator with hysteresis to give torque present and drive output open detection functions respectively. The upper and lower threshold currents are given as a percentage of motor current defined by Pr 5.07 (or Pr 21.07 if motor map 2 is selected). The upper threshold should be set to the current level that indicates that there is magnetising current and sufficient torque producing current in the motor to deliver the required amount of torque when the brake is released. The output of the comparator remains active after this level has been reached unless the current subsequently falls below the lower threshold which should be set to the required level to detect the condition where the motor has been disconnected from the drive. If the lower threshold is set greater or equal to the upper threshold, the upper threshold applies with a hysteresis band of zero. If Pr 12.42 and Pr 12.43 are both set to zero then the output of the comparator is always one.

12.44	Brake release frequency															
Coding	Bit	SP	FI	DE	Txt	VM	DP	ND	RA	NC	NV	PT	US	RW	BU	PS
							1						1	1	1	
Range	0 to 20.0 Hz															
Default	1.0															
Update rate	21 ms															

The frequency comparator can be used to detect when the motor frequency has reached a level where the motor can produce the required amount of torque to ensure that the motor rotates in the demanded direction when the brake is released. This parameter should be set to a level slightly above the motor slip frequency that is likely to occur under the highest expected load that is applied to the motor when the brake is released.

12.45	Brake apply frequency															
Coding	Bit	SP	FI	DE	Txt	VM	DP	ND	RA	NC	NV	PT	US	RW	BU	PS
							1						1	1	1	
Range	0 to 20.0 Hz															
Default	2.0															
Update rate	21 ms															

The brake apply frequency threshold is used to ensure that the brake is applied before the motor frequency reaches zero and to prevent the motor rotating (in the reverse direction due to an overhauling load for example) during the brake apply time. If the frequency falls below this threshold, but the motor is not required to stop (i.e. reversing direction without stopping), provided the reference on Pr 1.11 remains at one, the brake is not applied. This prevents the brake from activating and de-activating as the motor passes through zero speed.

12.46	Pre-brake release delay															
Coding	Bit	SP	FI	DE	Txt	VM	DP	ND	RA	NC	NV	PT	US	RW	BU	PS
							1						1	1	1	
Range	0.0 to 25.0 s															
Default	1.0															
Update rate	21 ms															

The pre-brake release delay is used to allow time for the motor torque to reach the required level before the brake is released. This time should allow for the motor flux to reach a significant proportion of the rated level (2 or 3 times the rotor time constant of the motor), and the time for slip compensation to become fully active (at least 0.5s). During the Pre-brake delay period the frequency reference is held constant (Pr 2.03 = 1).

12.47	Post-brake release delay															
Coding	Bit	SP	FI	DE	Txt	VM	DP	ND	RA	NC	NV	PT	US	RW	BU	PS
							1						1	1	1	
Range	0.0 to 25.0 s															
Default	1.0															
Update rate	21 ms															

The post-brake release delay is used to allow for the brake release time. During this period the frequency reference is held constant (Pr 2.03 = 1), so that there is no sudden increase in motor speed when the brake actually releases.

9.14 Menu 14: PID controller

Table 9-19 Menu 14 parameters: single line descriptions

Parameter		Range	Default	Setting	Update Rate
14.01	PID output	±100.0%			21 ms
14.02	PID main reference source	Pr 0.01 to Pr 21.51	Pr 0.00		Drive reset
14.03	PID reference source	Pr 0.01 to Pr 21.51	Pr 0.00		Drive reset
14.04	PID feedback source	Pr 0.01 to Pr 21.51	Pr 0.00		Drive reset
14.05	PID reference source invert	0 or 1	0		21 ms
14.06	PID feedback source invert	0 or 1	0		21 ms
14.07	PID reference slew rate limit	0.0 to 3200.0 s	0.0		B
14.08	PID enable	0 or 1	0		21 ms
14.09	Optional PID enable source	Pr 0.01 to Pr 21.51	Pr 0.00		Drive reset
14.10	PID proportional gain	0.000 to 4.000	1.000		21 ms
14.11	PID integral gain	0.000 to 4.000	0.500		21 ms
14.12	PID derivative gain	0.000 to 4.000	0.000		21 ms
14.13	PID high limit	0.0 to 100.0%	100.0		21 ms
14.14	PID low limit	±100.0%	-100.0		21 ms
14.15	PID scaling	0.000 to 4.000	1.000		21 ms
14.16	PID output destination	Pr 1.01 to Pr 21.51	Pr 0.00		Drive reset
14.17	Hold integrator	0 or 1	0		21 ms
14.18	Select symmetrical limit on PID	0 or 1	0		21 ms
14.19	Main reference	±100.0%			21 ms
14.20	PID reference	±100.0%			21 ms
14.21	PID feedback	±100.0%			21 ms
14.22	PID error	±100.0%			21 ms

Figure 9-42 Menu 14 logic diagram

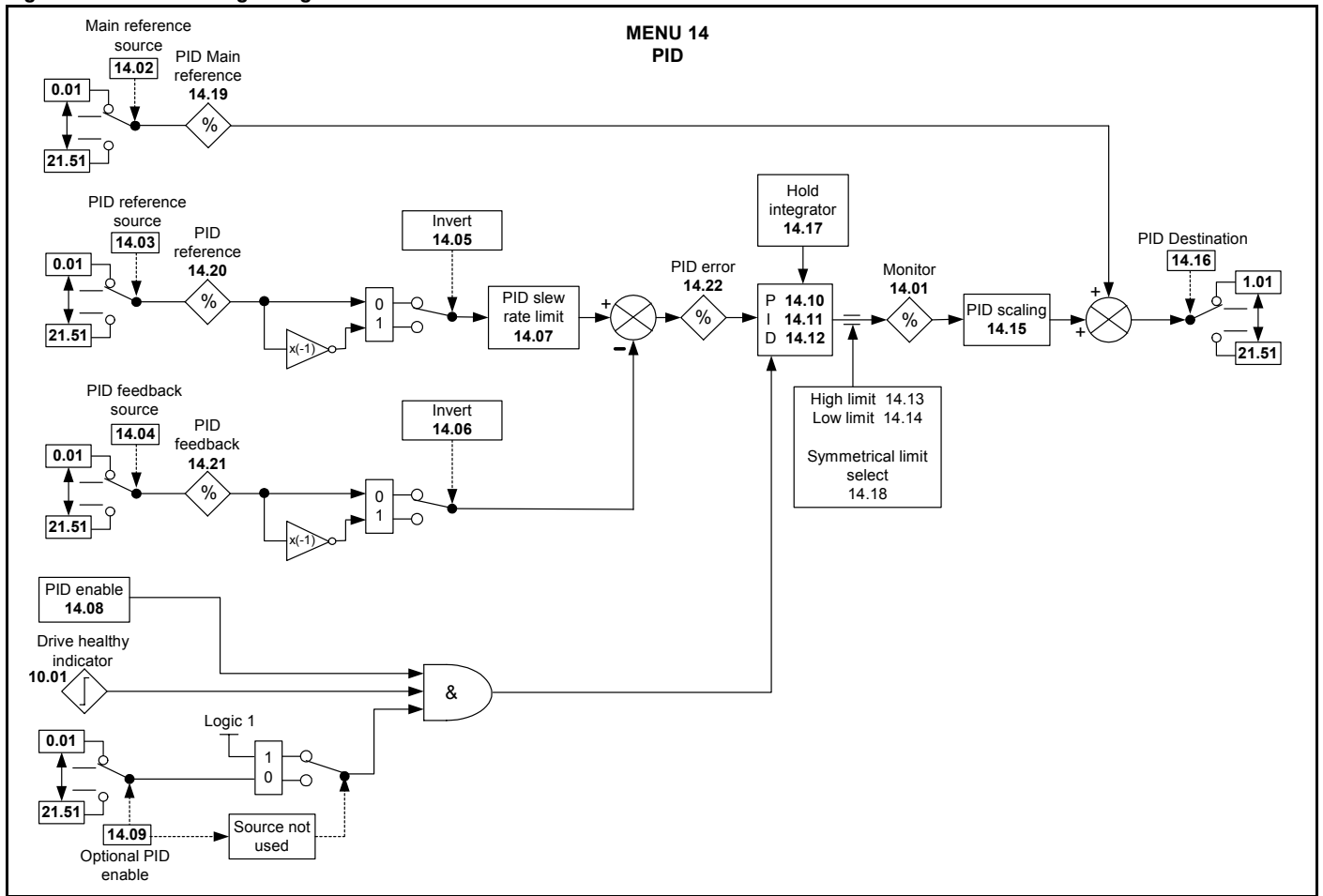

NOTE

The PID function is only active if the output destination is routed to a valid unprotected parameter. If only the indicator parameters are required, the destination parameter should be routed to an unused valid parameter.

14.01	PID output															
Coding	Bit	SP	FI	DE	Txt	VM	DP	ND	RA	NC	NV	PT	US	RW	BU	PS
							1	1		1		1				
Range	±100 %															
Update rate	21 ms															

This parameter monitors the output of the PID controller before scaling is applied. Subject to the PID output limits the PID output is given by:

$$\text{Output} = Pe + Ie/s + Des$$

Where:

- P = proportional gain (Pr 14.10)
- I = integral gain (Pr 14.11)
- D = differential gain (Pr 14.12)
- e = input error to the PID (14.22)
- s = Laplace operator

Therefore with an error of 100% and P = 1.00 the output produced by the proportional term is 100%. With an error of 100% and I = 1.00 the output produced by the integral term will increase linearly by 100% every second. With an error that is increasing by 100% per second and D = 1.00 the output produced by the D term will be 100%.

14.02	PID main reference source															
14.03	PID reference source															
14.04	PID feedback source															
Coding	Bit	SP	FI	DE	Txt	VM	DP	ND	RA	NC	NV	PT	US	RW	BU	PS
							2					1	1	1	1	
Range	Pr 0.01 to Pr 21.51															
Default	Pr 0.00															
Update rate	Read on drive reset															

These parameters define the variables which are to be used as the input variables to the PID controller. Only non-bit parameters can be programmed as a source. If a non valid parameter is programmed the input value is taken as 0. All variable inputs to the PID are automatically scaled to variables having the range of ±100.0% or 0 to 100% (of the source parameter) if they are unipolar.

14.05	PID reference source invert															
14.06	PID feedback source invert															
Coding	Bit	SP	FI	DE	Txt	VM	DP	ND	RA	NC	NV	PT	US	RW	BU	PS
	1												1	1		
Range	0 or 1															
Default	0															
Update rate	21 ms															

These parameters can be used to invert the PID reference and source variables respectively.

14.07	PID reference slew rate limit															
Coding	Bit	SP	FI	DE	Txt	VM	DP	ND	RA	NC	NV	PT	US	RW	BU	PS
							1						1	1	1	
Range	0.0 to 3200.0 s															
Default	0.0															
Update rate	Background															

This parameter defines the time taken for the reference input to ramp from 0.0 to 100.0% following a 0 to 100% step change in input.

14.08	PID enable															
Coding	Bit	SP	FI	DE	Txt	VM	DP	ND	RA	NC	NV	PT	US	RW	BU	PS
	1												1	1		
Range	0 or 1															
Default	0															
Update rate	21 ms															

This parameter must be at a 1 for the PID controller to operate, if it is 0 the PID output will be 0. If any changes are made to Pr 14.10, Pr 14.11 or Pr 14.12, then the PID enable must be set to a 0 then set to a 1 for the change to be set.

14.09	Optional PID enable source															
Coding	Bit	SP	FI	DE	Txt	VM	DP	ND	RA	NC	NV	PT	US	RW	BU	PS
							2					1	1	1	1	
Range	Pr 0.01 to Pr 21.51															
Default	Pr 0.00															
Update rate	Read on drive reset															

To enable the PID controller the drive must be healthy (Pr 10.01 = 1) and the PID enable (Pr 14.08) must be set to a 1. If the optional enable source (Pr 14.09) is 00.00 or routed to a non-existent parameter the PID controller is still enabled provided Pr 10.01 = 1 and Pr 14.08 = 1. If the optional enable source is routed to an existing parameter the source parameter must be one before the PID controller can be enabled. If the PID controller is disabled the output is zero and the integrator is set to zero.

14.10	PID proportional gain															
Coding	Bit	SP	FI	DE	Txt	VM	DP	ND	RA	NC	NV	PT	US	RW	BU	PS
							3						1	1	1	
Range	0.000 to 4.000															
Default	1.000															
Update rate	21 ms															

This is the proportional gain applied to the PID error.

14.11	PID integral gain															
Coding	Bit	SP	FI	DE	Txt	VM	DP	ND	RA	NC	NV	PT	US	RW	BU	PS
							3						1	1	1	
Range	0.000 to 4.000															
Default	0.500															
Update rate	21 ms															

This is the gain applied to the PID error before being integrated.

14.12	PID derivative gain															
Coding	Bit	SP	FI	DE	Txt	VM	DP	ND	RA	NC	NV	PT	US	RW	BU	PS
							3						1	1	1	
Range	0.000 to 4.000															
Default	0.000															
Update rate	21 ms															

This is the gain applied to the PID error before being differentiated.

14.13	PID high limit															
Coding	Bit	SP	FI	DE	Txt	VM	DP	ND	RA	NC	NV	PT	US	RW	BU	PS
							1						1	1	1	
Range	0.0 to 100.0 %															
Default	100.0															
Update rate	21 ms															

14.14	PID low limit															
Coding	Bit	SP	FI	DE	Txt	VM	DP	ND	RA	NC	NV	PT	US	RW	BU	PS
							1						1	1	1	
Range	±100.0 %															
Default	-100.0															
Update rate	21 ms															

If Pr 14.18 = 0, the upper limit (Pr 14.13) defines the maximum positive output for the PID controller and the lower limit (Pr 14.14) defines the minimum positive or maximum negative output. If Pr 14.18 = 1, the upper limit defines the maximum positive or negative magnitude for the PID controller output. When any of the limits are active the integrator is held.

14.15	PID scaling															
Coding	Bit	SP	FI	DE	Txt	VM	DP	ND	RA	NC	NV	PT	US	RW	BU	PS
							3					1	1	1	1	
Range	0.000 to 4.000															
Default	1.000															
Update rate	21 ms															

The PID output is scaled by this parameter before being added to the main reference. After the addition to the main reference, the output is automatically scaled again to match the range of the destination parameter.

14.16	PID output destination															
Coding	Bit	SP	FI	DE	Txt	VM	DP	ND	RA	NC	NV	PT	US	RW	BU	PS
				1			2					1	1	1	1	
Range	Pr 1.01 to Pr 21.51															
Default	Pr 0.00															
Update rate	Read on drive reset															

The destination parameter should be set up with the parameter that the PID controller is to control. Only non-bit parameters which are not protected can be controlled by the PID function. If a non valid parameter is programmed the output is not routed anywhere. If the PID is to control speed then it is suggested that one of the preset speed parameters is entered here.

14.17	Hold integrator															
Coding	Bit	SP	FI	DE	Txt	VM	DP	ND	RA	NC	NV	PT	US	RW	BU	PS
	1									1				1		
Range	0 or 1															
Default	0															
Update rate	21 ms															

When this parameter is set to 0 the integrator operates normally. Setting this parameter to 1 will cause the integrator value to be held as long as the PID is enabled when the drive is disabled. Setting this parameter does not prevent the integrator from being reset to zero if the PID controller is disabled.

14.18	Select symmetrical limit on PID															
Coding	Bit	SP	FI	DE	Txt	VM	DP	ND	RA	NC	NV	PT	US	RW	BU	PS
	1												1	1		
Range	0 or 1															
Default	0															
Update rate	21 ms															

See Pr 14.13 and Pr 14.14 on page 143.

14.19	Main reference															
Coding	Bit	SP	FI	DE	Txt	VM	DP	ND	RA	NC	NV	PT	US	RW	BU	PS
							1	1		1		1				
Range	±100.0 %															
Update rate	21 ms															

This parameter monitors the main reference input of the PID controller.

14.20	PID reference															
Coding	Bit	SP	FI	DE	Txt	VM	DP	ND	RA	NC	NV	PT	US	RW	BU	PS
							1	1		1		1				
Range	±100.0 %															
Update rate	21 ms															

This parameter monitors the reference input of the PID controller.

14.21	PID feedback															
Coding	Bit	SP	FI	DE	Txt	VM	DP	ND	RA	NC	NV	PT	US	RW	BU	PS
							1	1		1		1				
Range	±100.0 %															
Update rate	21 ms															

This parameter monitors the feedback input of the PID controller.

14.22	PID error															
Coding	Bit	SP	FI	DE	Txt	VM	DP	ND	RA	NC	NV	PT	US	RW	BU	PS
							1	1		1		1				
Range	±100.0 %															
Update rate	21 ms															

This parameter monitors the error of the PID controller.

9.15 Menu 15: I/O Option parameters

Table 9-20 Menu 15 parameters: single line descriptions

Parameter	Range	Default	Setting	Update Rate
15.01	Not used			
15.02	Not used			
15.03	Current loop loss indicator	0 or 1		BW
15.04	Terminal T5 digital input state	0 or 1		BW
15.05	Terminal T6 digital input state	0 or 1		BW
15.06	Terminal T7 digital input state	0 or 1		BW
15.07	Relay state (Terminals T21 and T23)	0 or 1		BW
15.08	Not used			
15.09	Not used			
15.10	Not used			
15.11	Not used			
15.12	Not used			
15.13	Not used			
15.14	Terminal T5 digital input invert	0 to 1	0	BR
15.15	Terminal T6 digital input invert	0 to 1	0	BR
15.16	Terminal T7 digital input invert	0 to 1	0	BR
15.17	Relay invert	0 to 1	0	BR
15.18	Not used			
15.19	Real time clock day light saving mode	0 to 1	0	BR
15.20	Digital I/O read word	0 to 255		BW
15.21	Not used			
15.22	Not used			
15.23	Not used			
15.24	Terminal T5 digital input destination	Pr 1.01 to Pr 21.51	Pr 0.00	Drive reset
15.25	Terminal T6 digital input destination	Pr 1.01 to Pr 21.51	Pr 0.00	Drive reset
15.26	Terminal T7 digital input destination	Pr 1.01 to Pr 21.51	Pr 0.00	Drive reset
15.27	Terminal T21/T23 relay source	Pr 0.01 to Pr 21.51	Pr 0.00	Drive reset
15.28	Not used			
15.29	Drive encoder speed feedback	-32000 to +32000 rpm		BW
15.30	Real time clock update mode	0 to 2	0	B R/W
15.31	Drive encoder lines per revolution	0 to 3	1	BR
15.32	Drive encoder revolution counter	0 to 65535		BW
15.33	Drive encoder position	0 to 65535 (1/2 ¹⁶ ths of a revolution)		BW
15.34	Real time clock minutes/seconds	00.00 to 59.59	00.00	B R/W
15.35	Real time clock days/hours	1.00 to 7.23	0.00	B R/W
15.36	Real time clock month date	00.00 to 12.31	00.00	B R/W
15.37	Real time clock years	2000 to 2099	2000	B R/W
15.38	Analog input 1 mode (Terminal T2)	0 to 6	0	BR
15.39	Analog output 1 mode (Terminal T3)	0 to 4	0	BR
15.40	Analog input 1 monitor (Terminal T2)	-100% to +100%		BW
15.41	Analog input 1 scaling (Terminal T2)	0.000 to 4.000	1.000	BR
15.42	Analog input 1 invert (Terminal T2)	0 to 1	0	BR
15.43	Analog input 1 destination (Terminal T2)	Pr 1.01 to Pr 21.51	Pr 0.00	Drive reset
15.44	Maximum drive encoder reference	0 to 32000 rpm	1500	BR
15.45	Drive encoder reference scaling	0.000 to 4.000	1.000	BR
15.46	Drive encoder reference monitor	-100% to +100%		BW
15.47	Drive encoder reference destination	Pr 1.01 to Pr 21.51	Pr 0.00	Drive reset
15.48	Analog output 1 source (Terminal T3)	Pr 0.01 to Pr 21.51	Pr 0.00	Drive reset
15.49	Analog output 1 scaling (Terminal T3)	0.000 to 4.000	1.000	BR

Figure 9-43 Menu 15A logic diagram

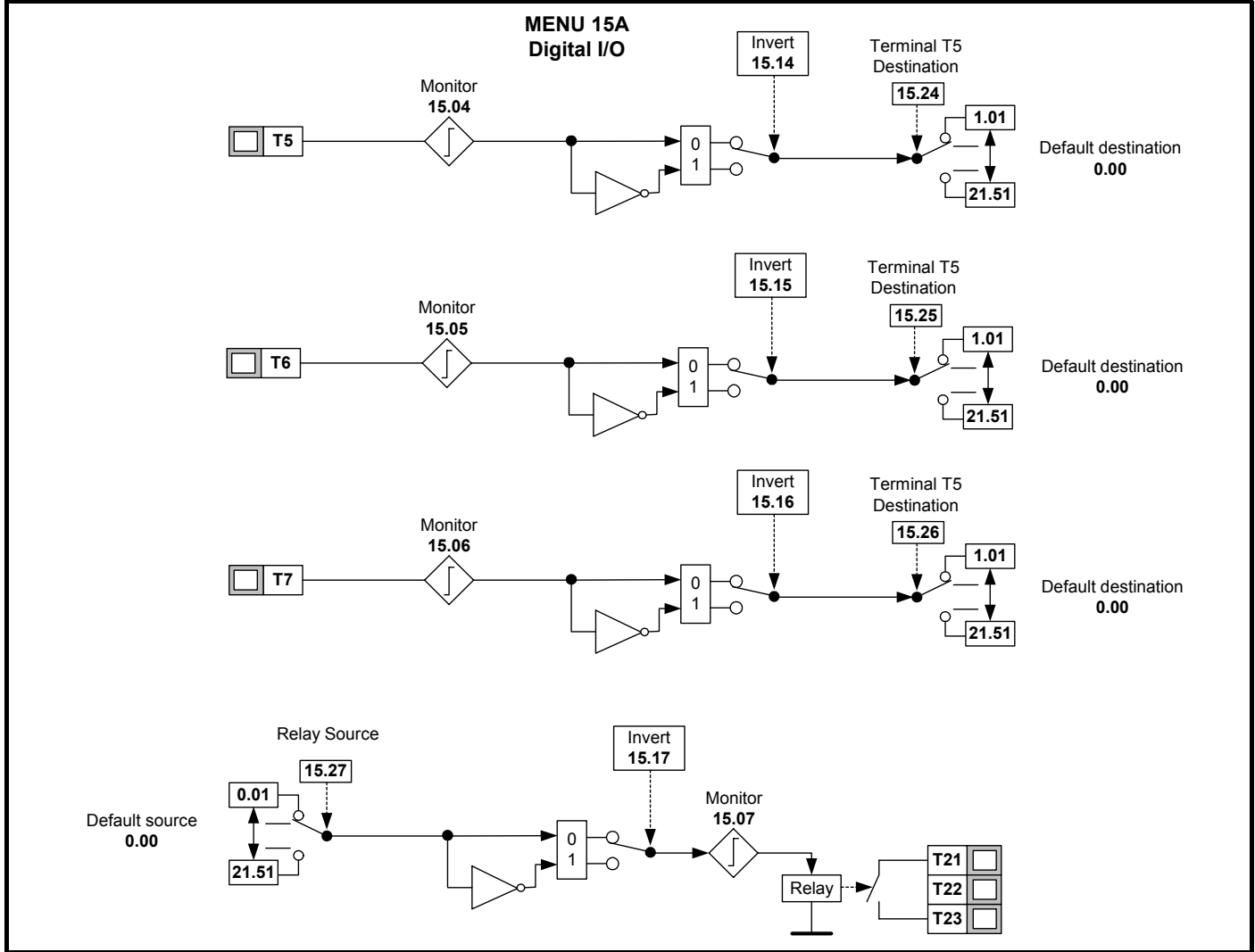

Figure 9-44 Menu 15B logic diagram

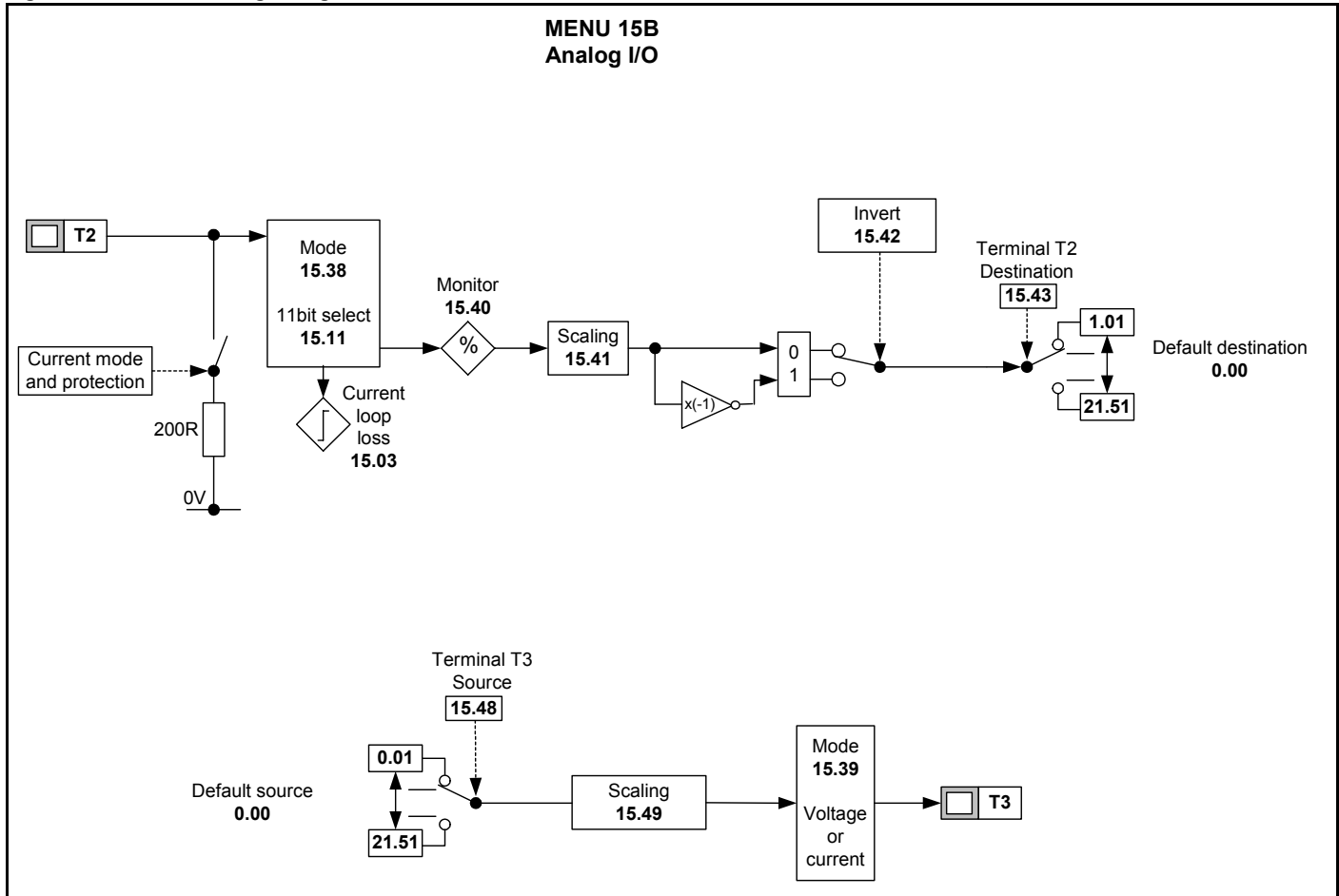

Figure 9-45 Menu 15C logic diagram

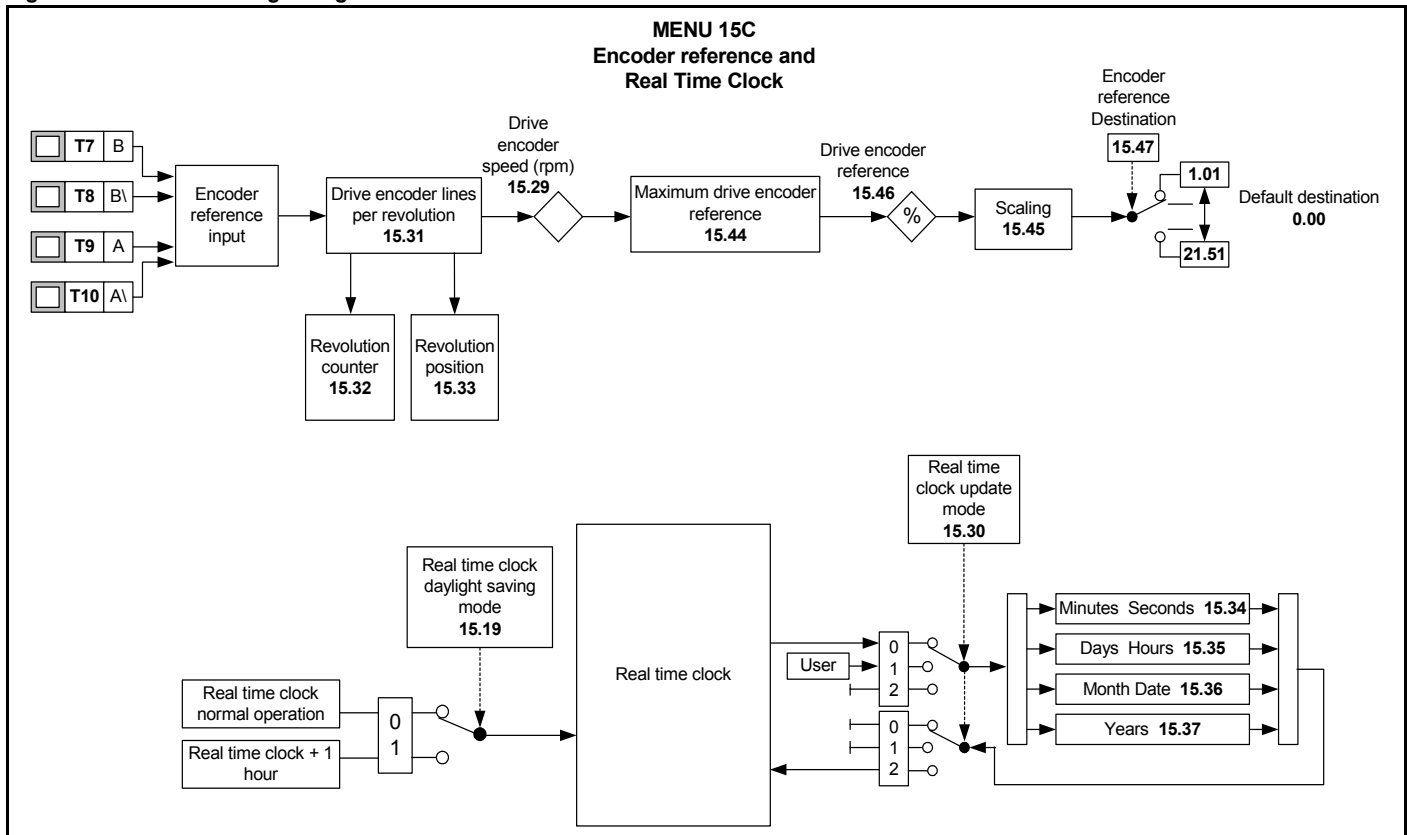
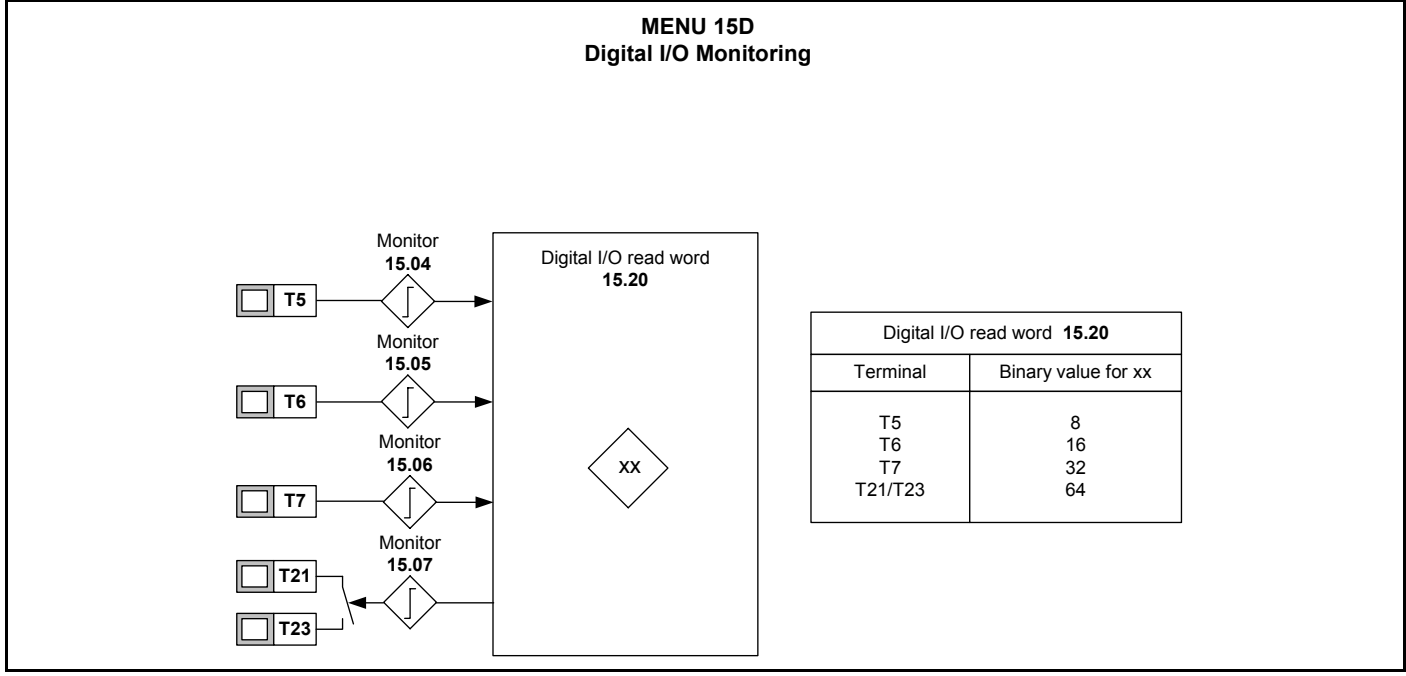

Figure 9-46 Menu 15D logic diagram



SM-I/O Lite & SM-I/O Timer

The Commander SK SM-I/O Lite & SM-I/O Timer options has an analog input that operates with 11 bit resolution in both voltage and current modes. The analog output has a resolution of approximately 13 bits ($\pm 1.25\text{mV}$ resolution in voltage mode and $\pm 2.5\mu\text{A}$ resolution in current mode).

Sample time/Update rate

The sample time/update rate of the parameters controlled by a destination or read by a source will be 2ms plus 2ms times the number of destinations or sources set up. For example, if only 2 digital inputs destinations are set-up, the parameters will be updated every 6ms. The software will cycle through the background read parameter in the 2ms slot.

Encoder input

The encoder input hardware is not a true quadrature input and may lose counts during direction change. The maximum input frequency is 55kHz

Error Codes

Error Code	Reason for Fault
0	No error
1	Digital output short circuit
2	Current input too high or too low
3	Encoder supply over current
4	I/O module serial communications error
5	Real time clock error
74	I/O option PCB over temperature ($>70^{\circ}\text{C}$)

The following parameters are available when an I/O option module is fitted to the drive.

15.01 to 15.02 Unused parameters

15.03	Current loop loss indicator															
Coding	Bit	SP	FI	DE	Txt	VM	DP	ND	RA	NC	NV	PT	US	RW	BU	PS
	1							1		1		1				
Range	0 or 1															
Update rate	Background write															

If the I/O options analog input is programmed in any of the modes 2 to 5 (see Pr 15.38) then this bit is set if the current input falls below 3mA. This bit can be designated to a digital output to indicate that the current input is less than 3mA.

NOTE

The digital inputs are set-up in positive logic only. This logic cannot be changed.

15.04	Terminal T5 digital input state															
15.05	Terminal T6 digital input state															
15.06	Terminal T7 digital input state															
Coding	Bit	SP	FI	DE	Txt	VM	DP	ND	RA	NC	NV	PT	US	RW	BU	PS
	1							1		1		1				
Range	0 or 1															
Update rate	Background write															

0 inactive

1 active.

These parameters indicate the state of the digital input terminals.

Terminals T5 to T7 are three programmable digital inputs.

If an external trip is required, then one of the terminals should be programmed to control the external trip parameter (Pr 10.32), with the invert set to a 1 so that the terminal must be made active for the drive not to trip.

15.07	Relay state (Terminals T21 and T23)															
Coding	Bit	SP	FI	DE	Txt	VM	DP	ND	RA	NC	NV	PT	US	RW	BU	PS
	1							1		1		1				
Range	0 or 1															
Update rate	Background write															

0: de-energised

1: energised

This parameter indicates the state of the drive's status relay

15.08 to 15.13 Unused parameters

15.14	Terminal T5 digital input invert															
15.15	Terminal T6 digital input invert															
15.16	Terminal T7 digital input invert															
Coding	Bit	SP	FI	DE	Txt	VM	DP	ND	RA	NC	NV	PT	US	RW	BU	PS
	1												1	1		
Range	0 to 1															
Default	0															
Update rate	Background read															

Setting these parameters to a 1 causes the input sense to the destination parameter to be inverted.

15.17	Relay invert															
Coding	Bit	SP	FI	DE	Txt	VM	DP	ND	RA	NC	NV	PT	US	RW	BU	PS
	1												1	1		
Range	0 to 1															
Default	0															
Update rate	Background read															

Setting this parameter to a 1 causes the relay sense to be inverted.

15.18	Unused parameter															
--------------	-------------------------	--	--	--	--	--	--	--	--	--	--	--	--	--	--	--

15.19	Real time clock day light saving mode															
Coding	Bit	SP	FI	DE	Txt	VM	DP	ND	RA	NC	NV	PT	US	RW	BU	PS
	1												1	1		
Range	0 to 1															
Default	0															
Update rate	Background read															

0 Real time clock normal operation

1 Real time clock + 1 hour

15.20	Digital I/O read word															
Coding	Bit	SP	FI	DE	Txt	VM	DP	ND	RA	NC	NV	PT	US	RW	BU	PS
								1		1		1			1	
Range	0 to 255															
Update rate	Background write															

This word is used to determine the status of the digital I/O by reading one parameter.

Pr 15.20 contains a binary value 'xx'. This binary value is determined by the state of Pr 15.04 to Pr 15.07. So for example, if all terminals were active the value displayed in Pr 15.20 would be the sum of the binary values shown in the table, i.e. 120.

Binary value for xx	Digital I/O
1	
2	
4	
8	Terminal T5
16	Terminal T6
32	Terminal T7
64	Terminals T8 & T9
128	

15.21 to 15.23	Unused parameters															
-----------------------	--------------------------	--	--	--	--	--	--	--	--	--	--	--	--	--	--	--

15.24	Terminal T5 digital input destination															
15.25	Terminal T6 digital input destination															
15.26	Terminal T7 digital input destination															
Coding	Bit	SP	FI	DE	Txt	VM	DP	ND	RA	NC	NV	PT	US	RW	BU	PS
				1			2					1	1	1	1	
Range	Pr 1.01 to Pr 21.51															
Default	Pr 0.00															
Update rate	Read on drive reset															

Destination parameters define the parameter each of the programmable inputs is to control. Only bit parameters that are not protected can be controlled by the programmable digital inputs. If a non-valid parameter is programmed, the digital input is not routed anywhere.

15.27	Terminal T21/T23 relay source															
Coding	Bit	SP	FI	DE	Txt	VM	DP	ND	RA	NC	NV	PT	US	RW	BU	PS
				1			2					1	1	1	1	
Range	Pr 0.01 to Pr 21.51															
Default	Pr 0.00															
Update rate	Read on drive reset															

This parameter defines the parameter to be represented by the status relay. Only bit parameters can be selected as a source for the relay output. If a non-valid parameter is programmed, then the relay will remain in the de-energised state.

15.28	Unused parameter															
--------------	-------------------------	--	--	--	--	--	--	--	--	--	--	--	--	--	--	--

15.29	Drive encoder speed feedback															
Coding	Bit	SP	FI	DE	Txt	VM	DP	ND	RA	NC	NV	PT	US	RW	BU	PS
			1					1		1		1				
Range	-32000 to + 32000 rpm															
Update rate	Background write															

This parameter shows the encoder speed in rpm provided that the set-up parameters for the drives encoder are correct.

15.30	Real time clock update mode															
Coding	Bit	SP	FI	DE	Txt	VM	DP	ND	RA	NC	NV	PT	US	RW	BU	PS
														1	1	
Range	0 to 2															
Default	0															
Update rate	Background read/write															

- 0: Real time clock parameters controlled by real time clock
- 1: Real time clock parameters controlled by user
- 2: Real time clock reads real time clock parameters and sets Pr 15.30 to 0

15.31	Drive encoder lines per revolution															
Coding	Bit	SP	FI	DE	Txt	VM	DP	ND	RA	NC	NV	PT	US	RW	BU	PS
					1								1	1	1	
Range	0 to 3															
Default	1															
Update rate	Background read															

- 0: 512 lines per revolution encoder
- 1: 1024 lines per revolution encoder
- 2: 2048 lines per revolution encoder
- 3: 4096 lines per revolution encoder

NOTE

A change to this parameter only takes effect when the drive is disabled, stopped or tripped.

15.32	Drive encoder revolution counter															
Coding	Bit	SP	FI	DE	Txt	VM	DP	ND	RA	NC	NV	PT	US	RW	BU	PS
			1					1		1		1			1	
Range	0 to 65535 revolutions															
Update rate	Background write															

15.33	Drive encoder position															
Coding	Bit	SP	FI	DE	Txt	VM	DP	ND	RA	NC	NV	PT	US	RW	BU	PS
			1					1		1		1			1	
Range	0 to 65535 (1/2 ¹⁶ ths of a revolution)															
Update rate	Background write															

15.34	Real time clock minutes/seconds															
Coding	Bit	SP	FI	DE	Txt	VM	DP	ND	RA	NC	NV	PT	US	RW	BU	PS
							2					1		1	1	
Range	00.00															
Default	00.00 to 59.59															
Update rate	Background read/write															

15.35	Real time clock days/hours															
Coding	Bit	SP	FI	DE	Txt	VM	DP	ND	RA	NC	NV	PT	US	RW	BU	PS
							2					1		1	1	
Range	00.0															
Default	1.00 to 7.23															
Update rate	Background read/write															

15.36	Real time clock month date															
Coding	Bit	SP	FI	DE	Txt	VM	DP	ND	RA	NC	NV	PT	US	RW	BU	PS
							2					1		1	1	
Range	00.00															
Default	00.00 to 12.31															
Update rate	Background read/write															

15.37	Real time clock years															
Coding	Bit	SP	FI	DE	Txt	VM	DP	ND	RA	NC	NV	PT	US	RW	BU	PS
												1		1	1	
Range	2000															
Default	2000 to 2099															
Update rate	Background read/write															

When an option with a real time clock is fitted, Pr 15.34 to Pr 15.37 will be controlled by the option.

15.38	Analog input 1 mode (Terminal T2)															
Coding	Bit	SP	FI	DE	Txt	VM	DP	ND	RA	NC	NV	PT	US	RW	BU	PS
					1								1	1		
Range	0 to 6															
Default	0															
Update rate	Background read															

Terminal T2 is a voltage/current reference input. The setting of this parameter configures the terminal for the required mode.

Value	Display	Function
0	0-20	0 to 20mA
1	20-0	20 to 0mA
2	4-20	4 to 20mA with trip on loss
3	20-4	20 to 4mA with trip on loss
4	4-.20	4 to 20mA with no trip on loss
5	20-.4	20 to 4mA with no trip on loss
6	VoLt	-10 to +10 volts

In modes 2 and 3, a current loop loss trip (cL) will be generated if the current input falls below 3mA.

NOTE

If 4-20 or 20-4 modes are selected and the drive trips on current loop loss (cL), analog reference 2 cannot be selected if the current reference is less than 3mA.

If 4-.20 or 20-.4 modes are selected, Pr 15.03 will switch from a 0 to 1 to indicate that the current reference is less than 3mA.

15.39	Analog output 1 mode (Terminal T3)															
Coding	Bit	SP	FI	DE	Txt	VM	DP	ND	RA	NC	NV	PT	US	RW	BU	PS
					1								1	1		
Range	0 to 4															
Default	0															
Update rate	Background read															

Terminal T3 is a voltage/current output. The setting of this parameter configures the terminal for the required mode.

Value	Display	Function
0	0-20	0 to 20mA
1	20-0	20 to 0mA
2	4-20	4 to 20mA
3	20-4	20 to 4mA
4	VoLt	0 to +10V

15.40	Analog input 1 monitor (Terminal T2)															
Coding	Bit	SP	FI	DE	Txt	VM	DP	ND	RA	NC	NV	PT	US	RW	BU	PS
							1	1		1		1				
Range	-100% to +100%															
Update rate	Background write															

This parameter displays the level of the analog signal present at analog input 1.

In voltage mode, this is a bipolar voltage input where the input range is -10V to +10V.

In current mode, this is a unipolar current input having a maximum measurable input of 20mA. The drive can be programmed to convert the measured current to any one of the defined ranges in Pr 15.38. The selected range is converted to 0 - 100.0%.

15.41	Analog input 1 scaling (Terminal T2)															
Coding	Bit	SP	FI	DE	Txt	VM	DP	ND	RA	NC	NV	PT	US	RW	BU	PS
							3						1	1	1	
Range	0.000 to 4.000															
Default	1.000															
Update rate	Background read															

This parameter is used to scale the analog input if so desired. However in most cases it is not necessary as each input is automatically scaled such that for 100.0%, the destination parameters (defined by the settings of Pr 15.43) will be at maximum.

15.42	Analog input 1 invert (terminal T2)															
Coding	Bit	SP	FI	DE	Txt	VM	DP	ND	RA	NC	NV	PT	US	RW	BU	PS
	1												1	1		
Range	0 to 1															
Default	0															
Update rate	Background read															

This parameter can be used to invert the analog input reference (i.e. multiply the input scaling result by -1)

15.43	Analog input 1 destination (Terminal T2)															
Coding	Bit	SP	FI	DE	Txt	VM	DP	ND	RA	NC	NV	PT	US	RW	BU	PS
							2					1	1	1	1	
Range	Pr 1.01 to Pr 21.51															
Default	Pr 0.00															
Update rate	Drive read on reset															

Only non-bit parameters that are not protected can be controlled by analog inputs. If a non-valid parameter is programmed to the destination of an analog input, the input is not routed anywhere. After a modification to this parameter, the destination is only changed when a reset is performed.

15.44	Maximum drive encoder reference															
Coding	Bit	SP	FI	DE	Txt	VM	DP	ND	RA	NC	NV	PT	US	RW	BU	PS
													1	1	1	
Range	0 to 32000 rpm															
Default	1500															
Update rate	Background read															

15.45	Drive encoder reference scaling															
Coding	Bit	SP	FI	DE	Txt	VM	DP	ND	RA	NC	NV	PT	US	RW	BU	PS
							3						1	1	1	
Range	0.000 to 4.000															
Default	1.000															
Update rate	Background read															

15.46	Drive encoder reference monitor															
Coding	Bit	SP	FI	DE	Txt	VM	DP	ND	RA	NC	NV	PT	US	RW	BU	PS
			1				1					1				
Range	-100% to +100%															
Update rate	Background write															

15.47	Drive encoder reference destination															
Coding	Bit	SP	FI	DE	Txt	VM	DP	ND	RA	NC	NV	PT	US	RW	BU	PS
				1			2					1	1	1	1	
Range	Pr 1.01 to Pr 21.51															
Default	Pr 0.00															
Update rate	Drive read on reset															

This parameter may be routed to any non-protected drive parameter.

After a modification to this parameter, the destination is only changed when a reset is performed.

15.48	Analog output 1 source (Terminal T3)															
Coding	Bit	SP	FI	DE	Txt	VM	DP	ND	RA	NC	NV	PT	US	RW	BU	PS
							2					1	1	1	1	
Range	Pr 0.01 to Pr 21.51															
Default	Pr 0.00															
Update rate	Drive read on reset															

The parameter required to be represented as an analog signal by the analog output on Terminal T3 should be programmed in this parameter. Only non-bit parameters that are not protected can be programmed as a source. If a non-valid parameter is programmed as a source, the output will remain at zero. After a modification to this parameter, the source is only changed when a reset is performed.

15.49	Analog output 1 scaling (Terminal T3)															
Coding	Bit	SP	FI	DE	Txt	VM	DP	ND	RA	NC	NV	PT	US	RW	BU	PS
							3						1	1	1	
Range	0.000 to 4.000															
Default	1.000															
Update rate	Background read															

This parameter can be used to scale the analog output if so desired. However in most cases it is not necessary as the output is automatically scaled such that when the source parameter is at its maximum, the analog output will be at its maximum.

9.16 Menu 18: Application menu 1

Table 9-21 Menu 18 parameters: single line descriptions

Parameter	Range	Default	Setting	Update Rate
18.01	Application menu 1 power-down saved integer	-32768 to 32767	0	N/A
18.02	Application menu 1 read-only integer	-32768 to 32767	0	N/A
18.03	Application menu 1 read-only integer	-32768 to 32767	0	N/A
18.04	Application menu 1 read-only integer	-32768 to 32767	0	N/A
18.05	Application menu 1 read-only integer	-32768 to 32767	0	N/A
18.06	Application menu 1 read-only integer	-32768 to 32767	0	N/A
18.07	Application menu 1 read-only integer	-32768 to 32767	0	N/A
18.08	Application menu 1 read-only integer	-32768 to 32767	0	N/A
18.09	Application menu 1 read-only integer	-32768 to 32767	0	N/A
18.10	Application menu 1 read-only integer	-32768 to 32767	0	N/A
18.11	Application menu 1 read-write integer	-32768 to 32767	0	N/A
18.12	Application menu 1 read-write integer	-32768 to 32767	0	N/A
18.13	Application menu 1 read-write integer	-32768 to 32767	0	N/A
18.14	Application menu 1 read-write integer	-32768 to 32767	0	N/A
18.15	Application menu 1 read-write integer	-32768 to 32767	0	N/A
18.16	Application menu 1 read-write integer	-32768 to 32767	0	N/A
18.17	Application menu 1 read-write integer	-32768 to 32767	0	N/A
18.18	Application menu 1 read-write integer	-32768 to 32767	0	N/A
18.19	Application menu 1 read-write integer	-32768 to 32767	0	N/A
18.20	Application menu 1 read-write integer	-32768 to 32767	0	N/A
18.21	Application menu 1 read-write integer	-32768 to 32767	0	N/A
18.22	Application menu 1 read-write integer	-32768 to 32767	0	N/A
18.23	Application menu 1 read-write integer	-32768 to 32767	0	N/A
18.24	Application menu 1 read-write integer	-32768 to 32767	0	N/A
18.25	Application menu 1 read-write integer	-32768 to 32767	0	N/A
18.26	Application menu 1 read-write integer	-32768 to 32767	0	N/A
18.27	Application menu 1 read-write integer	-32768 to 32767	0	N/A
18.28	Application menu 1 read-write integer	-32768 to 32767	0	N/A
18.29	Application menu 1 read-write integer	-32768 to 32767	0	N/A
18.30	Application menu 1 read-write integer	-32768 to 32767	0	N/A
18.31	Application menu 1 read-write bit	0 to 1	0	N/A
18.32	Application menu 1 read-write bit	0 to 1	0	N/A
18.33	Application menu 1 read-write bit	0 to 1	0	N/A
18.34	Application menu 1 read-write bit	0 to 1	0	N/A
18.35	Application menu 1 read-write bit	0 to 1	0	N/A
18.36	Application menu 1 read-write bit	0 to 1	0	N/A
18.37	Application menu 1 read-write bit	0 to 1	0	N/A
18.38	Application menu 1 read-write bit	0 to 1	0	N/A
18.39	Application menu 1 read-write bit	0 to 1	0	N/A
18.40	Application menu 1 read-write bit	0 to 1	0	N/A
18.41	Application menu 1 read-write bit	0 to 1	0	N/A
18.42	Application menu 1 read-write bit	0 to 1	0	N/A
18.43	Application menu 1 read-write bit	0 to 1	0	N/A
18.44	Application menu 1 read-write bit	0 to 1	0	N/A
18.45	Application menu 1 read-write bit	0 to 1	0	N/A
18.46	Application menu 1 read-write bit	0 to 1	0	N/A
18.47	Application menu 1 read-write bit	0 to 1	0	N/A
18.48	Application menu 1 read-write bit	0 to 1	0	N/A
18.49	Application menu 1 read-write bit	0 to 1	0	N/A
18.50	Application menu 1 read-write bit	0 to 1	0	N/A

Menu 18 contains parameter that do not affect the operation of the drive. These general purpose parameters are intended for use with fieldbus and drive user programming. The read write parameters in this menu can be saved in the drive.

18.01	Application menu 1 power-down saved integer															
Coding	Bit	SP	FI	DE	Txt	VM	DP	ND	RA	NC	NV	PT	US	RW	BU	PS
										1				1		1
Range	-32768 to 32767															
Default	0															
Update rate	N/A															

18.02 to 18.10	Application menu 1 read-only integer															
Coding	Bit	SP	FI	DE	Txt	VM	DP	ND	RA	NC	NV	PT	US	RW	BU	PS
										1						
Range	-32768 to 32767															
Default	0															
Update rate	N/A															

18.11 to 18.30	Application menu 1 read-write integer															
Coding	Bit	SP	FI	DE	Txt	VM	DP	ND	RA	NC	NV	PT	US	RW	BU	PS
													1	1		
Range	-32768 to 32767															
Default	0															
Update rate	N/A															

18.31 to 18.50	Application menu 1 read-write bit															
Coding	Bit	SP	FI	DE	Txt	VM	DP	ND	RA	NC	NV	PT	US	RW	BU	PS
	1												1	1		
Range	0 or 1															
Default	0															
Update rate	N/A															

9.17 Menu 20: Application menu 2

Table 9-22 Menu 20 parameters: single line descriptions

Parameter	Range	Default	Setting	Update Rate
20.00	Not used			
20.01	Not used			
20.02	Not used			
20.03	Not used			
20.04	Not used			
20.05	Not used			
20.06	Not used			
20.07	Not used			
20.08	Not used			
20.09	Not used			
20.10	Not used			
20.11	Not used			
20.12	Not used			
20.13	Not used			
20.14	Not used			
20.15	Not used			
20.16	Not used			
20.17	Not used			
20.18	Not used			
20.19	Not used			
20.20	Not used			
20.21	Application menu 2 read-write long integer	-2^{31} to $2^{31}-1$	0	N/A
20.22	Application menu 2 read-write long integer	-2^{31} to $2^{31}-1$	0	N/A
20.23	Application menu 2 read-write long integer	-2^{31} to $2^{31}-1$	0	N/A
20.23	Application menu 2 read-write long integer	-2^{31} to $2^{31}-1$	0	N/A
20.24	Application menu 2 read-write long integer	-2^{31} to $2^{31}-1$	0	N/A
20.25	Application menu 2 read-write long integer	-2^{31} to $2^{31}-1$	0	N/A
20.26	Application menu 2 read-write long integer	-2^{31} to $2^{31}-1$	0	N/A
20.26	Application menu 2 read-write long integer	-2^{31} to $2^{31}-1$	0	N/A
20.27	Application menu 2 read-write long integer	-2^{31} to $2^{31}-1$	0	N/A
20.28	Application menu 2 read-write long integer	-2^{31} to $2^{31}-1$	0	N/A
20.29	Application menu 2 read-write long integer	-2^{31} to $2^{31}-1$	0	N/A
20.30	Application menu 2 read-write long integer	-2^{31} to $2^{31}-1$	0	N/A

Menu 20 contains parameters that do not affect the operation of the drive. These general purpose parameters are intended for use with fieldbus and drive user programming. The read write parameters in this menu cannot be saved in the drive.

20.00 to 20.20 Unused parameters

20.21 to 20.30 Application menu 2 read-write long integer	
Coding	Bit SP FI DE Txt VM DP ND RA NC NV PT US RW BU PS
	1 1
Range	-2^{31} to $2^{31}-1$
Default	0
Update rate	N/A

9.18 Menu 21: Second motor map

Table 9-23 Menu 21 parameters: single line descriptions

Parameter	Range	Default	Setting	Update Rate
21.01	Motor 2 maximum set speed	0.0 to 1500.0 Hz	50(EUR), 60(USA)	B
21.02	Motor 2 minimum set speed	0.0 to Pr 1.06	0.0	B
21.03	Motor 2 reference selector	0 to 5	0	5 ms
21.04	Motor 2 acceleration rate	0.0 to 3200.0 s/100 Hz	5.0	5 ms
21.05	Motor 2 deceleration rate	0.0 to 3200.0 s/100 Hz	10.0	5 ms
21.06	Motor 2 motor rated frequency	0.0 to 1500.0 Hz	50.0(EUR), 60.0(USA)	B
21.07	Motor 2 motor rated current	0 to RATED_CURRENT_MAX A	Drive rated current {Pr 11.32}	B
21.08	Motor 2 motor rated load rpm	0 to 9999 rpm	1500(EUR), 1800(USA)	B
21.09	Motor 2 motor rated voltage	0 to AC_VOLTAGE_SET_MAX V	200 V drive: 230 400 V drive: 400(EUR) 460(USA)	128 ms
21.10	Motor 2 motor rated power factor	0.00 to 1.00	0.85	B
21.11	Motor 2 number of poles	0 to 4	0	B
21.12	Motor 2 stator resistance	0.000 to 30.000 Ω	0.000	B
21.13	Motor 2 voltage offset	0.0 to 25.0 V	0.0	B
21.14	Motor 2 transient inductance (σL_s)	0.000 to 320.00 mH	0.000	B
21.15	Motor 2 active	0 to 1	0	B
21.16	Motor 2 thermal time constant	0 to 250	89	B
21.17	Not used			
21.18	Not used			
21.19	Not used			
21.20	Not used			
21.21	Not used			
21.22	Not used			
21.23	Not used			
21.24	Not used			
21.25	Not used			
21.26	Not used			
21.27	Not used			
21.28	Not used			
21.29	Motor 2 symmetrical current limit	0 to MOTOR2_CURRENT_LIMIT_MAX %	165.0	B

21.01	Motor 2 maximum set speed															
Coding	Bit	SP	FI	DE	Txt	VM	DP	ND	RA	NC	NV	PT	US	RW	BU	PS
							1						1	1	1	
Range	0.0 to 1500.0 Hz															
Default	EUR: 50.0 USA: 60.0															
First motor parameter	Pr 1.06															
Update rate	Background															

This parameter is a symmetrical limit on both directions of rotation.

Defines drive absolute maximum frequency reference. Slip compensation and current limit can increase the motor frequency further.

21.02	Motor 2 minimum set speed															
Coding	Bit	SP	FI	DE	Txt	VM	DP	ND	RA	NC	NV	PT	US	RW	BU	PS
						1	1						1	1	1	
Range	0.0 to 1500.0 Hz															
Default	0.0															
First motor parameter	Pr 1.07															
Update rate	Background															

Used in unipolar mode to define drive minimum set speed. This can be overridden if the maximum set speed clamp Pr 21.01 is adjusted to be less than Pr 21.02. Inactive during jogging.

21.03	Motor 2 reference selector															
Coding	Bit	SP	FI	DE	Txt	VM	DP	ND	RA	NC	NV	PT	US	RW	BU	PS
					1								1	1	1	
Range	0 to 5															
Default	0 (AI.AV)															
First motor parameter	Pr 1.14															
Update rate	5ms															

This parameter is used to select a speed reference for motor 2 as follows:

- 0: AI.AV Analog reference 1 or 2 selected by terminal input
- 1: AV.Pr Analog reference 1 (voltage) or Presets selected by terminal input
- 2: AI.Pr Analog reference 1 (current) or Presets selected by terminal input
- 3: Pr Preset reference selected by terminal
- 4: PAd Keypad reference selected
- 5: Prc Precision reference selected

Pr 21.03	Terminal T4 destination	Terminal B7 destination	Pr 1.49
0 (AI.AV)	Pr 1.37	Pr 1.41	Selected by terminal input
1 (AV.Pr)	Pr 1.45	Pr 1.46	1
2 (AI.Pr)	Pr 1.45	Pr 1.46	2
3 (Pr)	Pr 1.45	Pr 1.46	3
4 (PAd)			4
5 (Prc)			5

When this parameter is set to 0 the reference selected depends on the state of bit parameters Pr 1.41 to Pr 1.44. These bits are for control by digital inputs such that references can be selected by external control. If any of the bits are set, the appropriate reference is selected (indicated by Pr 1.49). If more than one bit is set the highest numbered will have priority.

In modes 1 and 2 a preset speed will be selected instead of the voltage or current selection, if the preset selected is any preset speed other than preset speed 1. This gives the user the flexibility to be able to select between voltage and 3 presets, or current and three presets, with only two digital inputs.

Pr 1.41	Pr 1.42	Pr 1.43	Pr 1.44	Reference selected	Pr 1.49
0	0	0	0	Analog reference 1 (AI)	1
1	0	0	0	Analog reference 2 (AV)	2
X	1	0	0	Preset reference (Pr)	3
X	X	1	0	Keypad reference (PAd)	4
X	X	X	1	Precision reference (Prc)	5

Keypad reference

If Keypad reference is selected, the drive sequencer is controlled directly by the keypad keys and the keypad reference parameter (Pr 1.17) is selected. The sequencing bits, Pr 6.30 to Pr 6.34, have no effect and jog is disabled.

NOTE

There is no forward/ reverse button on the drives keypad. If a forward/ reverse is required in keypad mode, see Pr 11.27 for how to set this up.

Note: For existing users of Commander SE:

On Commander SE, Pr 1.14 (Pr 21.03) used to correspond to Pr 05.

On Commander SK, Pr 11.27 corresponds to Pr 05.

If Pr 05 or Pr 11.27 is used in a desired system set-up and then Pr 1.14 (Pr 21.03) is then used to change this set-up, although some of these set-ups for Pr 05 and Pr 1.14 (Pr 21.03) are the same, the displayed value showing the set-up of Pr 05 (AI, AV, Pr etc.) will not change to the setting of Pr 1.14 (Pr 21.03)

21.04	Motor 2 acceleration rate															
Coding	Bit	SP	FI	DE	Txt	VM	DP	ND	RA	NC	NV	PT	US	RW	BU	PS
							1						1	1	1	
Range	0 to 3200.0s/100 Hz															
Default	5.0															
First motor parameter	Pr 2.11															
Update rate	5ms															

Defines the acceleration ramp for motor 2

The acceleration ramp rate units can be change to s/10Hz or s/1000Hz, see Pr 2.39 on page 39 for details.

21.05	Motor 2 deceleration rate															
Coding	Bit	SP	FI	DE	Txt	VM	DP	ND	RA	NC	NV	PT	US	RW	BU	PS
							1						1	1	1	
Range	0 to 3200.0 s/100 Hz															
Default	10.0															
First motor parameter	Pr 2.21															
Update rate	5ms															

Defines the deceleration ramp for motor 2

The deceleration ramp rate units can be change to s/10Hz or s/1000Hz, see Pr 2.21 on page 38 for details.

21.06	Motor 2 motor rated frequency															
Coding	Bit	SP	FI	DE	Txt	VM	DP	ND	RA	NC	NV	PT	US	RW	BU	PS
							1						1	1	1	
Range	0.0 to 1500.0 Hz															
Default	EUR: 50.0, USA 60.0															
First motor parameter	Pr 5.06															
Update rate	Background															

The motor rated frequency and the motor rated voltage (Pr 21.09) are used to define the voltage to frequency characteristic applied to the drive (see Pr 21.09). The motor rated frequency is also used in conjunction with the motor full load rpm to calculate the rated slip for slip compensation (see Pr 21.08 on page 162).

21.07	Motor 2 motor rated current															
Coding	Bit	SP	FI	DE	Txt	VM	DP	ND	RA	NC	NV	PT	US	RW	BU	PS
						1	2		1				1	1	1	
Range	0 to RATED_CURRENT_MAX A															
Default	Drive rated current (Pr 11.32)															
First motor parameter	Pr 5.07															
Update rate	Background															

The motor rated current should be set at the machine nameplate value for rated current.

This value is used in the following:

- Current limit, see Pr 21.29 on page 165
- Motor protection system, see Pr 21.16 on page 165
- Slip compensation, see Pr 21.08
- Vector mode voltage control, see Pr 21.09
- Dynamic V to f control, see Pr 5.13 on page 61

21.08	Motor 2 motor rated full load rpm															
Coding	Bit	SP	FI	DE	Txt	VM	DP	ND	RA	NC	NV	PT	US	RW	BU	PS
													1	1	1	
Range	0 to 9999															
Default	EUR: 1500, USA 1800															
First motor parameter	Pr 5.08															
Update rate	Background															

The rated full load rpm is used with the motor rated frequency and No. of poles to calculate the rated slip of the induction machine in Hz.

$$\text{Rated slip} = \text{Motor rated frequency} - (\text{No. of motor pole pairs} \times \text{Motor full load rpm} / 60) = \text{Pr 21.06} - [(\text{Pr 21.11} / 2) \times (\text{Pr 21.08} / 60)]$$

The rated slip is used to calculate the frequency adjustment required to compensate for slip from the following equation:

$$\text{Slip compensation} = \text{Rated slip} \times \text{Active current} / \text{Rated active current}$$

If slip compensation is required, Pr 5.27 must be set to a 1 and this parameter should be set to the nameplate value, which should give the correct rpm for a hot machine.

Sometimes it will be necessary to adjust this when the drive is commissioned because the nameplate value may be inaccurate. Slip compensation will operate correctly both below rated speed and within the field weakening region. Slip compensation is normally used to correct for the motor speed to prevent speed variation with load. The rated load rpm can be set higher than synchronous speed to deliberately introduce speed droop. This can be useful to aid load sharing with mechanically coupled motors.

NOTE

If Pr 21.08 is set to 0 or to synchronous speed, slip compensation is disabled.

NOTE

If the full load speed of the motor is above 9999rpm, slip compensation should be disabled. This is because a value above 9999 cannot be entered in Pr 21.08.

21.09	Motor 2 motor rated voltage															
Coding	Bit	SP	FI	DE	Txt	VM	DP	ND	RA	NC	NV	PT	US	RW	BU	PS
						1			1				1	1	1	
Range	0 to AC_VOLTAGE_SET_MAX V															
Default	200V rating drive: 230V 400V rating drive: EUR: 400V, USA: 460V															
First motor parameter	Pr 5.09															
Update rate	128ms															

The rated voltage is used in conjunction with the motor rated frequency (Pr 21.06) to define the voltage to frequency characteristic applied to the motor. The following operating methods selected by Pr 5.14 are used to define the drive frequency to voltage characteristic.

Open-loop vector mode: Ur S, Ur A, Ur or Ur I

A linear characteristic is used from 0Hz to rated frequency, and then a constant voltage above rated frequency. When the drive operates between rated frequency/50 and rated frequency/4, full vector based stator resistance (Rs) compensation is applied. However there is a delay of 0.5s when the drive is enabled during which only partial vector based compensation is applied to allow the machine flux to build up. When the drive operates between rated frequency/4 and rated frequency/2 the Rs compensation is gradually reduced to zero as the frequency increases. For the vector

modes to operate correctly the stator resistance (Pr 21.12), motor rated power factor (Pr 21.10) and voltage offset (Pr 21.13) are all required to be set-up accurately.

Fixed boost mode: Fd

A linear characteristic is used from 0Hz to rated frequency, and then constant voltage above rated frequency. Low frequency voltage boost as defined by Pr 5.15 is applied as shown below.

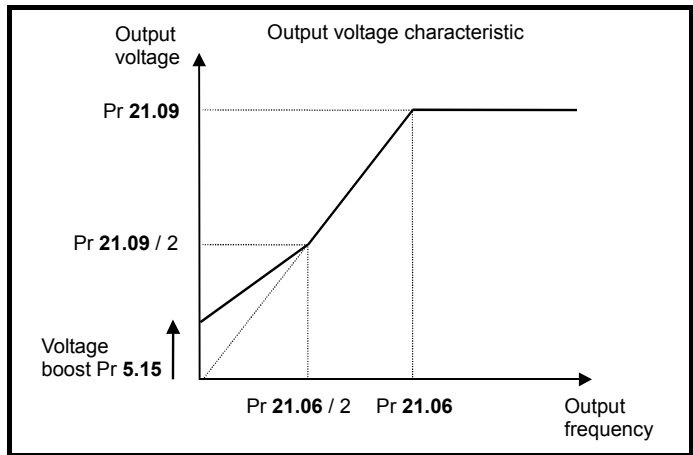

Square law mode: SrE

A square law characteristic is used from 0Hz to rated frequency, and then constant voltage above rated frequency. Low frequency voltage boost raises the start point of the square law characteristic as shown below.

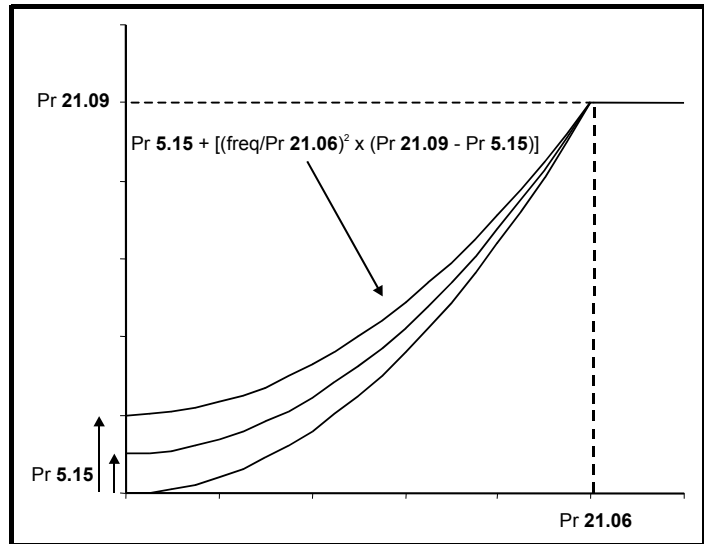

21.10	Motor 2 motor rated power factor															
Coding	Bit	SP	FI	DE	Txt	VM	DP	ND	RA	NC	NV	PT	US	RW	BU	PS
							2						1	1	1	
Range	0.00 to 1.00															
Default	0.85															
First motor parameter	Pr 5.10															
Update rate	Background															

The power factor is the true power factor of the motor, i.e. the angle between the motor voltage and current. The power factor is used in conjunction with the motor rated current (Pr 21.07) to calculate the rated active current and magnetising current of the motor. The rated active current is used extensively to control the drive, and the magnetising current is used in vector mode Rs compensation. It is important that this parameter is set up correctly.

21.11	Motor 2 number of motor poles															
Coding	Bit	SP	FI	DE	Txt	VM	DP	ND	RA	NC	NV	PT	US	RW	BU	PS
					1								1	1	1	
Range	0 (Auto), 1 (2P), 2 (4P), 3 (6P), 4 (8P)															
Default	0 (Auto)															
First motor parameter	Pr 5.11															
Update rate	Background															

Poles by text (value on display)	Pole pairs (value through serial comms)
Auto	0
2P	1
4P	2
6P	3
8P	4

This parameter is used in the calculation of motor speed and in applying the correct slip compensation. When auto is selected the number of motor poles is automatically calculated from the rated frequency (Pr 21.06) and the rated load rpm (Pr 21.08).

The number of poles = $120 \times \text{rated frequency} / \text{rpm}$ rounded to the nearest even number.

21.12	Motor 2 stator resistance															
Coding	Bit	SP	FI	DE	Txt	VM	DP	ND	RA	NC	NV	PT	US	RW	BU	PS
							3		1				1	1	1	
Range	0.000 to 30.000 Ω															
Default	3.0															
First motor parameter	Pr 5.17															
Update rate	Background															

This parameter contains the stator resistance of the machine for open loop vector mode operation.

If the drive cannot achieve the necessary current levels to measure the stator resistance during an auto-tune (e.g. there is no motor connected to the drive) an rS trip will occur and the value in Pr 21.12 remains unchanged. If the necessary current levels can be achieved but the calculated resistance exceeds the maximum allowable value for that particular drive size, an rS trip will occur and Pr 21.12 will contain the maximum allowable value.

21.13	Motor 2 voltage offset															
Coding	Bit	SP	FI	DE	Txt	VM	DP	ND	RA	NC	NV	PT	US	RW	BU	PS
							1		1				1	1	1	
Range	0.0 to 25.0 V															
Default	0.0															
First motor parameter	Pr 5.23															
Update rate	Background															

Due to various effects in the drive inverter a voltage offset must be produced before any current flows. To obtain good performance at low frequencies where the machine terminal voltage is small this offset must be taken into account. The value shown in Pr 21.13 is this offset given in line to line rms volts. It is not possible for the user to measure this voltage easily, and so the automatic measurement procedure should be used (see Pr 5.14 on page 62).

21.14	Motor 2 transient inductance (σL_s)															
Coding	Bit	SP	FI	DE	Txt	VM	DP	ND	RA	NC	NV	PT	US	RW	BU	PS
							2		1				1		1	
Range	0.000 to 320.00 mH															
Default	0.000															
First motor parameter	Pr 5.24															
Update rate	Background															

With reference to the following diagram, the transient inductance is defined as

$$\sigma L_s = L_1 + (L_2 \cdot L_m / (L_2 + L_m))$$

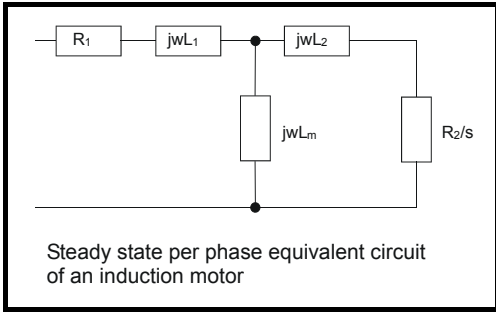

Based on the parameters normally used for the motor equivalent circuit for transient analysis, i.e. $L_s = L_1 + L_m$, $L_r = L_2 + L_m$, the transient inductance is given by:

$$\sigma L_s = L_s - (L_m^2 / L_r)$$

The transient inductance is used as an intermediate variable to calculate the power factor.

21.15	Motor 2 active															
Coding	Bit	SP	FI	DE	Txt	VM	DP	ND	RA	NC	NV	PT	US	RW	BU	PS
	1							1		1		1				
Range	0 or 1															
Default	0															
Update rate	Background															

When this parameter is set to a 1, it signifies that motor map 2 is active.

This parameter can be programmed to a digital output to give a signal to an external circuit to close a second motor contactor when motor map 2 becomes active.

21.16	Motor 2 thermal time constant															
Coding	Bit	SP	FI	DE	Txt	VM	DP	ND	RA	NC	NV	PT	US	RW	BU	PS
													1	1	1	
Range	0 to 250 s															
Default	89															
First motor parameter	Pr 4.15															
Update rate	Background															

Pr 21.16 works in conjunction with Pr 4.16 and Pr 4.25. The motor protection modes set-up by Pr 4.16 and Pr 4.25 for motor 1 will be used for motor 2 but the thermal time constant for motor 2 will be defined in Pr 21.16.

See Pr 4.16 on page 51 and Pr 4.25 on page 54 for further details.

21.17 to 21.28	Unused parameters
-----------------------	--------------------------

21.29	Motor 2 symmetrical current limit															
Coding	Bit	SP	FI	DE	Txt	VM	DP	ND	RA	NC	NV	PT	US	RW	BU	PS
						1	1		1				1	1	1	
Range	0 to MOTOR1_CURRENT_LIMIT_MAX %															
Default	165.0															
First motor parameter	Pr 4.07															
Update rate	Background															

This parameter defines the current limit as a percentage of the rated active current. When the motor rated current is set lower than the drive rated current, the maximum value of this parameter increases to allow larger overloads.

Therefore, by setting the motor rated current to a lower value than the drive rated current, it is possible to have a current limit greater than 165%. An absolute maximum current limit of 999.9% is applied.

In frequency control mode (Pr 4.11 = 0), the drive output frequency is modified if necessary to keep the active current within the current limits as shown in the following diagram:

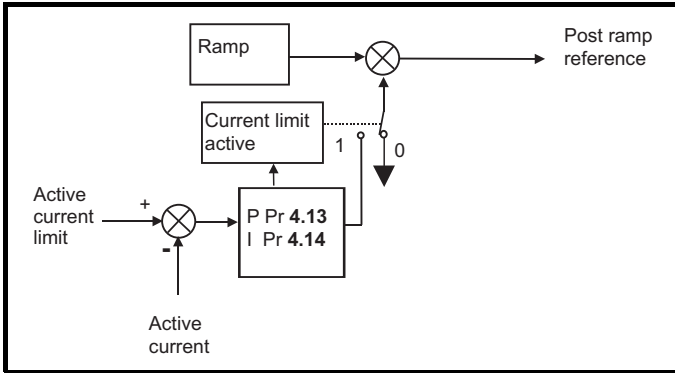

The active current limit is compared with the active current and if the current exceeds the limit the error value passes through the PI controller to give a frequency component which is used to modify the ramp output. The direction of the modification is always to reduce the frequency to zero if the active current is motoring, or to increase the frequency towards the maximum if the current is regenerating. Even when the current limit is active the ramp still operates, therefore the proportional and integral gains (Pr 4.13 and Pr 4.14) must be high enough to counter the effects of the ramp. For method of setting the gains see Pr 4.13 and Pr 4.14 on page 50.

In torque control mode the current demand is limited by the active current limit. For operation of this mode see Pr 4.11 on page 50.



0472-0001-02