

HIGH PERFORMANCE ALL-DIGITAL SUPER LOW-NOISE
GENERAL-PURPOSE INVERTER DRIVES

Varispeed-616G3 plus

200 to 230V 0.5 to 100HP (0.4 to 75kW) (1.4 to 130kVA)
380 to 460V 0.5 to 400HP (0.4 to 300kW) (1.4 to 510kVA)
500 to 600V 2 to 200HP (1.5 to 160kW) (2 to 200kVA)

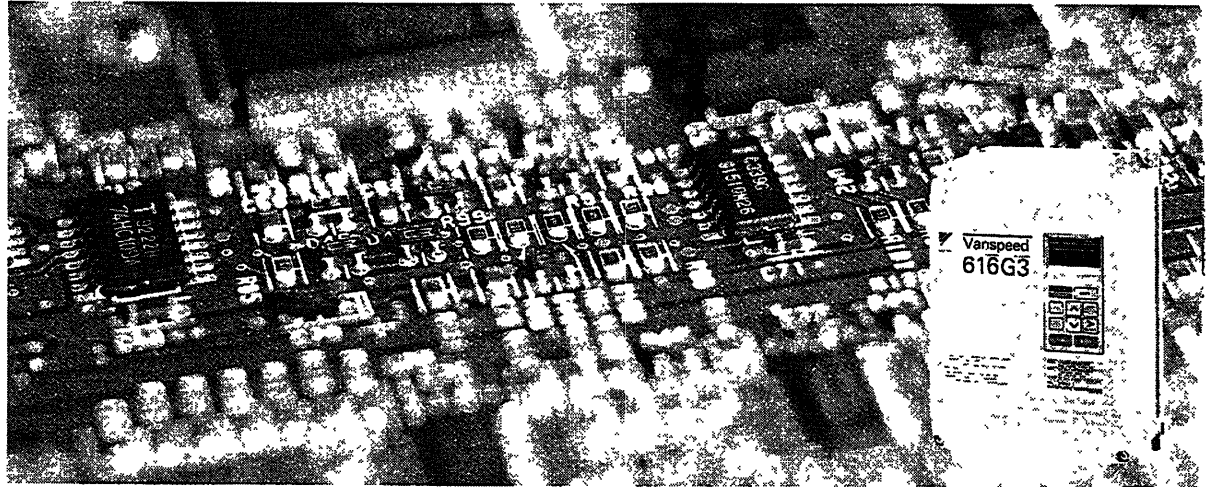

CONTENTS

SPECIFICATIONS	
Standard Specifications	14
Enclosures and Model Designation	17
Mounting Dimensions	18-42
Cooling Fin and Heat Loss	43-44
Panel Cut	45-47
Functions of the Digital Operator	48-49
VALUES OF CONSTANTS	
System Constant (Sn)	50-51
Control Constant (Cn)	52
Frequency Reference (Ar)	53
Constant to Change during Rimming (Bn)	53
SELECTION AND SETTING OF VARIOUS FUNCTIONS	
TERMINALS AND STANDARD CONNECTION	62-65
PROTECTIVE, WARNING, AND SELF-DIAGNOSIS FUNCTIONS	66-69
NOTES ON OPERATION	
Notes on Use of Inverter	70
Notes on Use of Peripherals	71
VALUES OF OPTIONS	
Option Units	75
Built-in Option Cards	76-77
Braking Resistor-Braking Unit	
Braking Resistor Unit	78-85
AC Reactor	81
Molded-Case Circuit Breaker (MCCB) and Power Supply Magnetic Contactor (MC)	82
Noise Filter	83-85
Frequency Meter Mounting Base	86
Isolator	87
VS System Module	88-91
NOTES	
Notes on Application of Motors	92
Motor Output Torque Characteristics	93
INDEX	
ALPHABETICALLY	94-101
APPENDICES	102-105
OVERVIEW OF SOFTWARE	106
APPENDIX A	107
APPENDIX B	108
APPENDIX C	109
APPENDIX D	110
APPENDIX E	111
APPENDIX F	112
APPENDIX G	113
APPENDIX H	114
APPENDIX I	115
APPENDIX J	116
APPENDIX K	117
APPENDIX L	118
APPENDIX M	119
APPENDIX N	120
APPENDIX O	121
APPENDIX P	122
APPENDIX Q	123
APPENDIX R	124
APPENDIX S	125
APPENDIX T	126
APPENDIX U	127
APPENDIX V	128
APPENDIX W	129
APPENDIX X	130
APPENDIX Y	131
APPENDIX Z	132

YASKAWA'S SOFTWARE BASED INVERTER FOR OPTIMUM MACHINE PERFORMANCE

A tough, effective, and adaptable inverter is a must for top performance of high-tech machines. Yaskawa's is a software based inverter which offers the flexibility to take full advantage of your machine's performance.

As a successor to the highly successful VS-616G2, the Varispeed-616G3 plus (VS-616G3 plus) has been designed as a full software inverter. Its enhanced functions and performance guarantee that throughout the 90's the VS-616G3 plus will set the standard that other inverters will be judged by.

With its vast experience in motor drive manufacturing, YASKAWA developed the VS-616G3 plus as an inverter that adds value to your machine.



692-545
692-546

YASKAWA inverters provide sign

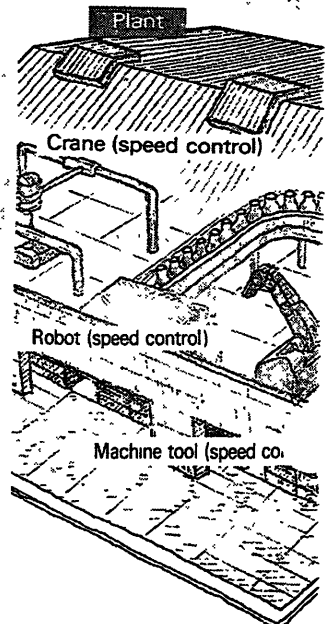
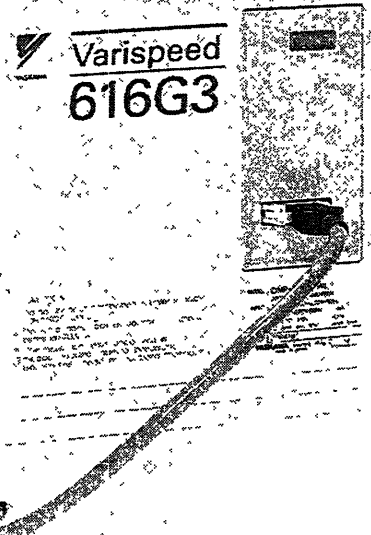
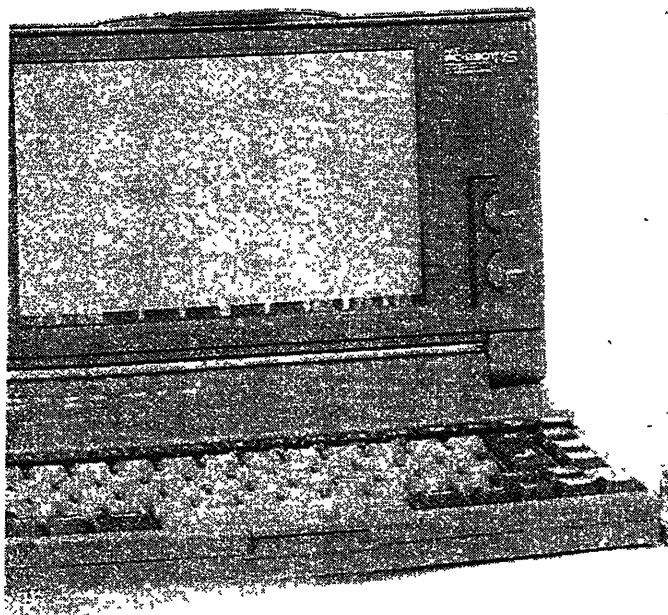
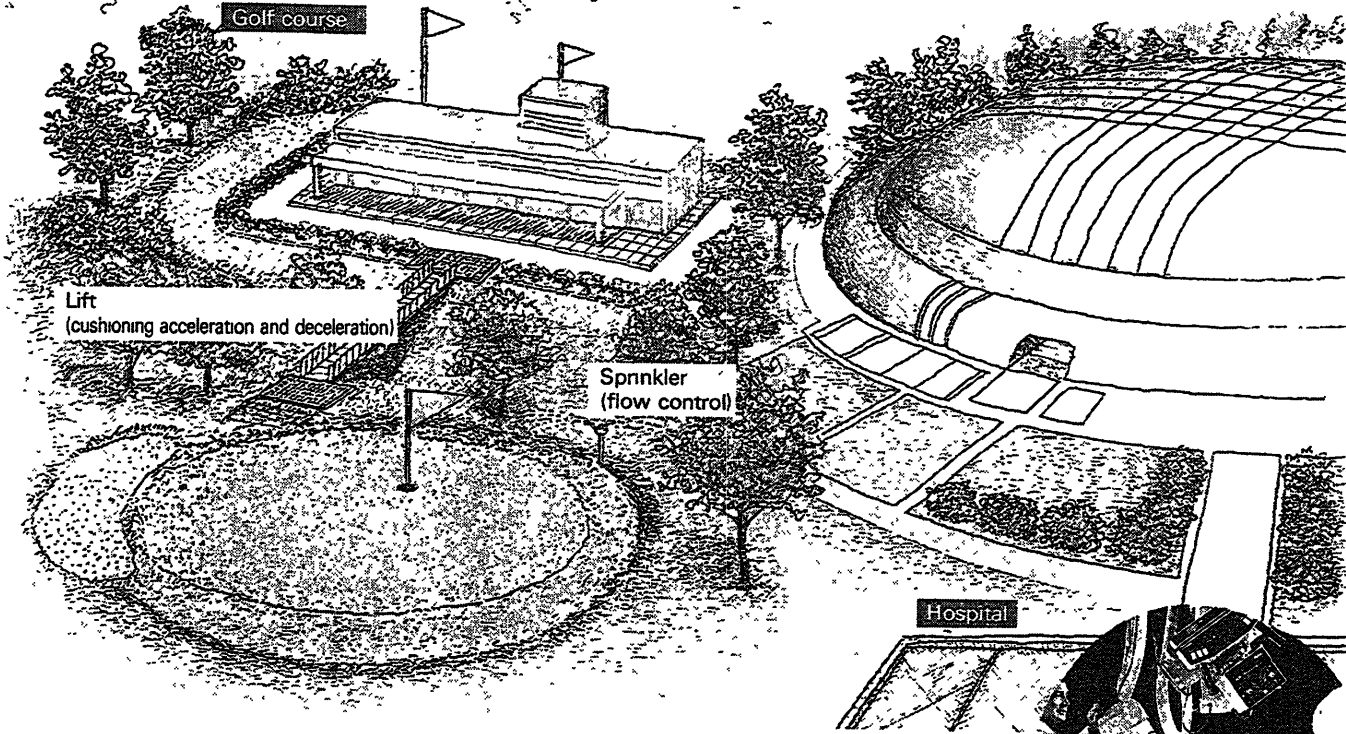

ficant improvements

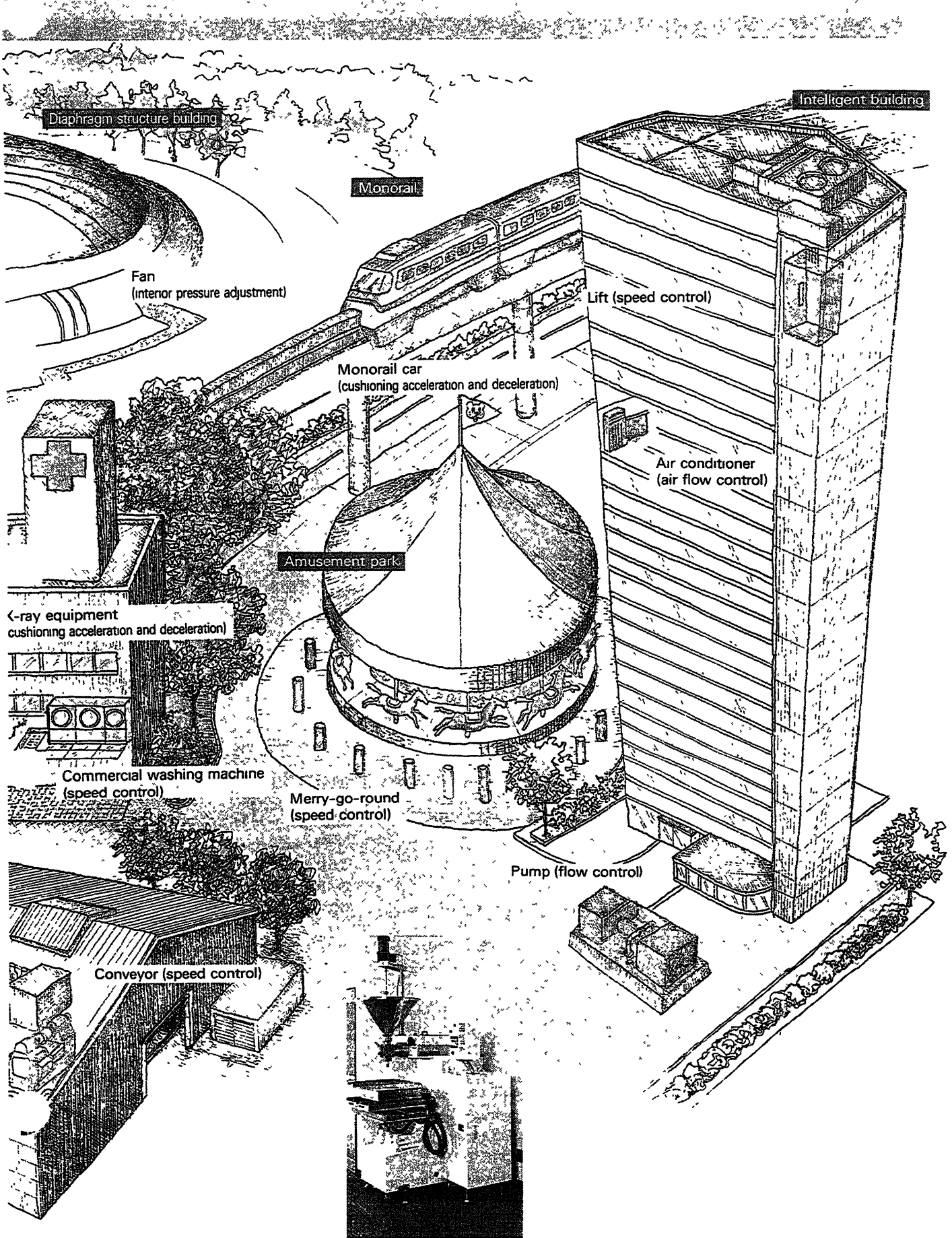

Diaphragm structure building

Intelligent building

Monorail

Fan
(interior pressure adjustment)

Lift (speed control)

Monorail car
(cushioning acceleration and deceleration)

Air conditioner
(air flow control)

Amusement park

X-ray equipment
(cushioning acceleration and deceleration)

Commercial washing machine
(speed control)

Merry-go-round
(speed control)

Pump (flow control)

Conveyor (speed control)

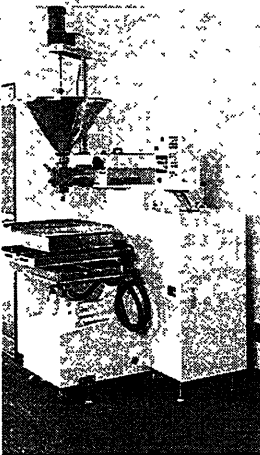

Mixer (Program Operation) 189-51

SUPER LOW-NOISE DRIVE ... IGBT

General-purpose inverter with advanced functions and low noise

All VS-616G3 plus series models employ IGBT for switching. The high-speed switching of the IGBT has changed the very concept of inverter control. Precise waveform control coupled with the high performance of the IGBT provides numerous advantages such as quiet operation, high starting torque, smoother shaft rotation and improved reliability.

Current Wave Example at 10Hz

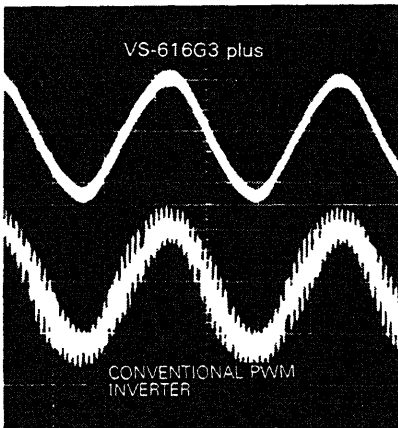

IGBT

Insulated Gate Bi-polar Transistor

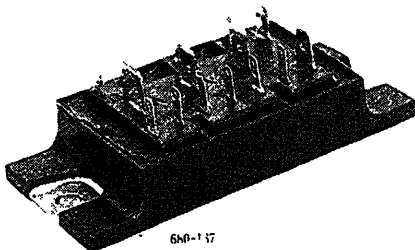

Features of IGBT (Insulated Gate Bi-polar Transistor)

- Minimal-loss, high-speed switching up to larger ampere ratings
- Direct drive through logic circuitry because of voltage-driven element
- Can accommodate 575V power supply

As quiet as running with commercial power

Employing our original asynchronous high-carrier technique for sine wave PWM control, we have succeeded in eliminating the motor noises that plagued conventional PWM inverters.

Running noise has been reduced by approximately 20 dB as compared to conventional PWM inverters. This quiet operation assures a more comfortable working environment.

Motor Noise Comparison

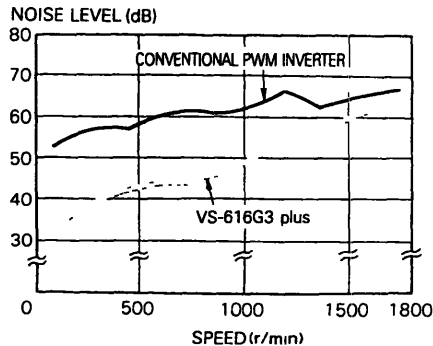

Tough inverters with utmost reliability

Standardized control circuits, custom LSI with original high integration design, latest surface mounted technology (SMT), and our IGBT direct drive technique-all combine to provide a compact and highly reliable inverter.

Compact and highly reliable control board with SMT

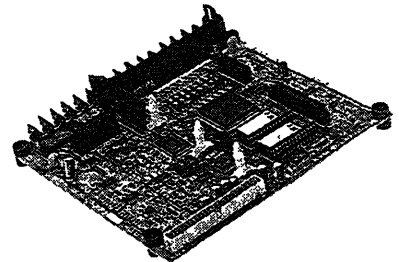

692-547

Exclusive-use ROM customizes the inverter for your machine control.

- Specialized ROM for cranes and hoists. This provides a slipping down prevention and an output phase interruption protection.
- Specialized ROM to correspond max. frequency 800Hz.
- Process control specialized ROM with built-in PID control.
- Energy-saving control specialized ROM to greatly reduce motor running costs.

Note: Specify the desired ROM on your order.

Water and dust tight type (NEMA4 Model)
200 to 230/380 to 460V
3 to 10HP (2.2 to 7.5kW)
Standard



693-86

INVERTER

Torque exceeding 150% under operation at 1Hz

Any type of machine starts smoothly
(High-torque Tripless Operation Even at Low Speed)

Two types of control can be selected depending on the applications.

■ With V/f control (general purpose) which is applicable for any type of motor (Torque exceeding 150% at 1/20 speed)

The fully-automatic torque boost feature based on our unique vector control operation and exact sine wave drive ensures maximum performance whenever it is needed. This tough, no-stall inverter won't trip even if overloaded.

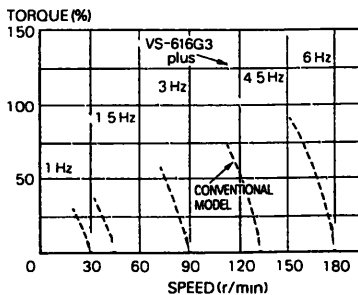

■ Voltage-type vector control combined with YASKAWA standard motor (Torque exceeding 150% under operation at 1Hz)

Simply change to encoder-less voltage-type vector control using exclusive-use ROM. Smooth starting at heavy loads and high-accuracy positioning are possible. Specify "voltage-type vector control incorporating type" on your order.

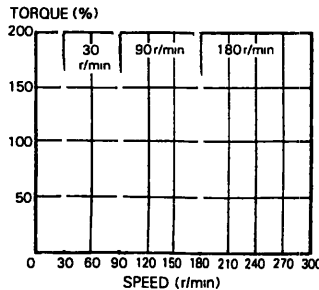

A variety of models

The IGBT series consists of a variety of inverters from which you can select the optimum model for your machine.

MAX APPLICABLE MOTOR OUTPUT HP (KW)	STANDARD		UL/CSA STANDARD		
	200V	400V	200V	400V	600V
0.5 (0.4)					
1 (0.75)					
2 (1.5)					
3 (2.2)	*	*	†	†	
5 (3.7)	*	*	†	†	
7.5 (5.5)	*	*	†	†	
10 (7.5)	*	*	†	†	
15 (11)					
20 (15)					
25 (18.5)					
30 (22)					
40 (30)					
50 (37)					
60 (45)					
75 (55)				†	
100 (75)				†	
120 (90)					
150 (110)				†	
200 (160)				†	
250 (185)					
300 (220)					
400 (300)					

*Water and dust tight type (NEMA4 model) is also available.

† Certification is pending for water and dust tight type (NEMA4 model).

‡ Certification is pending for low-noise type.

Note:

1. Colored boxes are the low noise type and non-colored boxes are compact low-carrier frequency type.
2. For 600V class, contact your YASKAWA representative.

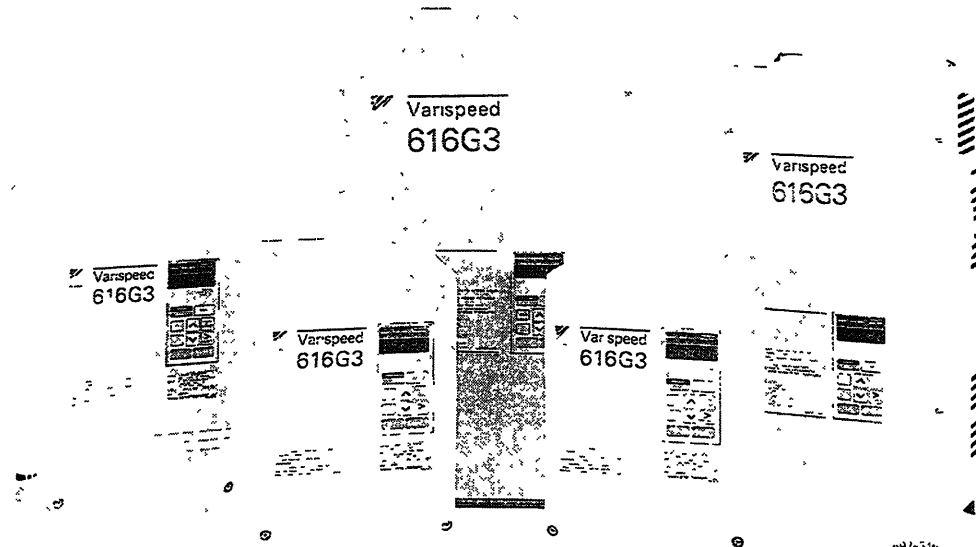

Your Machine becomes "one-of-a-kind."

The new intelligent inverter was designed based on accumulated know-how in motor drives. The versatility of the new fully-digital software inverter satisfies numerous needs and enables you to upgrade your machines. A broad function selection allows rapid and significant changes in your machine's performance. UL and CSA certified products back up your global strategies.

UL listed



CSA listed



Note: The above listed are available for models

CIMR-G3U□
-G3V□.

Global service network

Our quality assurance service network covers the USA, Europe, and Southeast Asia. UL and CSA certified products fit your global strategies.

Many Functions for Dramatic Enhancement

Consolidated monitoring functions for operating state

In addition to the conventional monitoring items, frequency input, output frequency, output current, output voltage, DC voltage, output power, and I/O terminal state are also indicated digitally to facilitate monitoring of machine operation. Alarm contents are retained in memory even at power off.

OUTPUT FREQUENCY INDICATION EXAMPLE

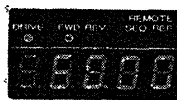

Digital indication of operating frequency makes checking of operating state easy

MOTOR CURRENT INDICATION EXAMPLE



Direct indication of motor current allows easy verification of loads

DC VOLTAGE INDICATION EXAMPLE



Input power can be checked by one-touch operation. The rectified value of input voltage can be read directly

ALARM MESSAGE INDICATION EXAMPLE



Should an error occur, the cause is indicated and kept in memory. Error history is retained for troubleshooting

OUTPUT POWER DISPLAY EXAMPLE



Output power is read on digital display or output terminals so that load status is clear. Energy savings can be easily monitored with the output power display

INPUT TERMINAL STATUS DISPLAY EXAMPLE



Contact states "open" and "closed" are read directly from the display to simple system troubleshooting

Basic and application functions ready to use

Over 200 intelligent functions including overtorque detection, reverse prevention, and frequency upper and lower limiter are supplied as standard. The following new functions are also provided:

- External control of accel/decel (by switching or analog input) (See pages 54 and 56.)
- Variable output voltage function by external signals (See page 55.)
- UP/DOWN function (See page 55.)

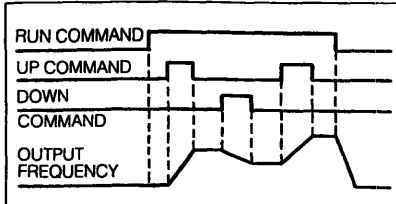

Simple multi-step operation

Operation speed can be set by up to nine steps by switching four-contact input signals. Various sequence operations can also be easily set. (See pages 44 and 53.)

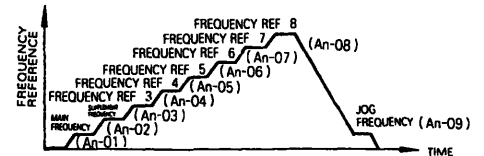

High grade I/O functions

The advanced multi-function I/O terminals adapt the inverter to each machine. Just set system constants with the digital operator to customize the I/O terminals.

INPUT SIGNAL

STANDARD SETTING (2-WIRE SEQUENCE)

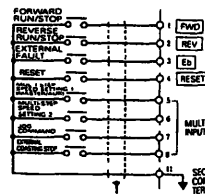

CUSTOMIZED SETTING EXAMPLE (3 WIRE EXAMPLE)

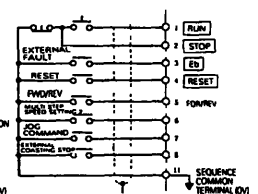

Note (Sn-15=00)

OUTPUT SIGNAL

STANDARD SETTING

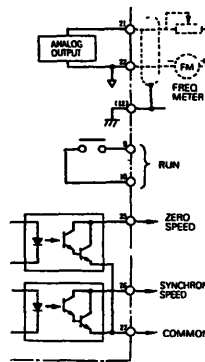

CUSTOMIZED SETTING EXAMPLE

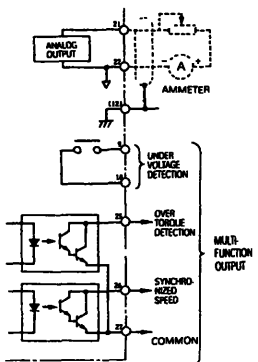

Note [Sn-05=1 x x x
Sn-20=07
Sn-21=0 B]

For other options refer to page 12, 13.

with the Highly Flexible Software Control

Our Machines Capability

A well-stocked software library customizes the inverter for each machine

The software library of the highly regarded VS-616G2 has been further enhanced to optimize the inverter for any machine.

- Adjusts the motor voltage to the optimum level by exact calculation of torque required for the load. This assures continuous operation even under overload conditions.

(Full-range, fully automatic torque boost) by vector control operation

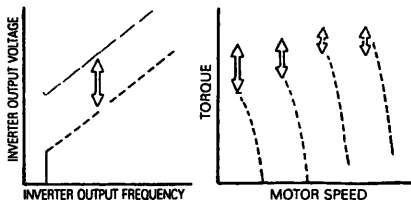

- Guarantees high-precision and constant operation regardless of load fluctuations. (See page 54.) Slip compensation circuit reduces motor slip to less than 1%. Use of PG speed control card (PG-C) improves up to approx. 0.03%.

(Example of 200V, 10HP (7.5kW), 4-pole motor)

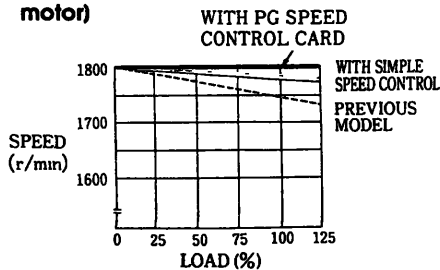

Quickly recovers from external problems and continues operation to assure final product quality.

- Two seconds momentary power loss ride-thru. (See page 51.)
0.5 to 1 sec for less than 3HP (2.2kW), 230V / 460V
(2 sec ride-thru is optional)

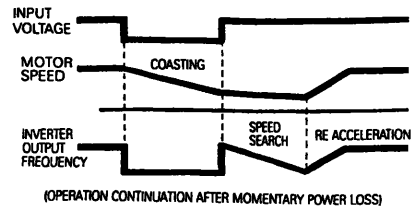

- Automatic restart after fault (See page 53.) After a fault occurs, the microcomputer performs self diagnosis and restarts automatically without stopping motor. (Up to 10 retries)
- Accel/decel (See page 51.) The stall prevention at running function ensures tripless operation.

Various monitors

A scalable analog output for frequency or current measurement is provided as a standard. Changing the ammeter, voltmeter, and wattmeter outputs is also possible by setting system constants. (See page 45.)

For applications requiring more feedback, an optional AO-08 board allows three signals to be output. If two analog output signals are required, use option AO-08 or AO-12.

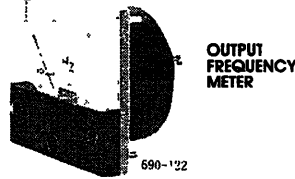

Enhanced output interface

Two new open collector output signals (a total of three output signals including the contact output) together with the multi-function output selection make possible more enhanced control of machines. (See page 55.)

- At zero-speed, at set speed, at set speed with hysteresis on decel ramp or accel ramp. (as standard)
- Frequency detection (detects a set frequency, below or above)
- Overtorque detected (machine overloaded)
- Low voltage detected (Input voltage insufficient)
- Others

Load operation indication

The output frequency can be scaled such that many units such as motor speed, load axis speed (r/min), line speed (m/min), and flow (m³/min) may be indicated. (See page 53.)

MOTOR SPEED DISPLAY (1800 r/min)

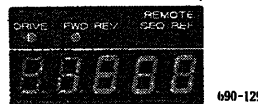

Easy set-up

Accel/dec time, frequency reference, and frequency meter scale, among others, can be adjusted while the machine is running. This speeds start-up and reduces downtime for system tuning.

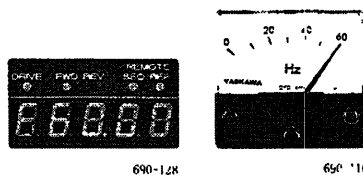

Easy link with PLC by digital setting.

Easy to link with PLC

Motor speed can be precisely set with an external signal. Either 4 digits BCD (binary code decimal) or 16 binary bits can be used (on-board option).

DIGITAL REFERENCE CARD DI-16

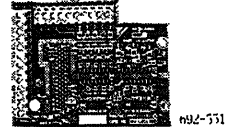

Computer link

Computer control with a personal computer or high-order sequencer can be accomplished through RS-232C, -422, -485 high-speed communication interface

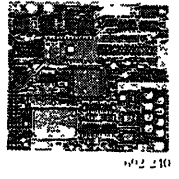

High-accuracy operation by speed feedback control

Speed regulation caused by slip is minimized using speed feedback function of pulse generator (PG) mounted on a motor.

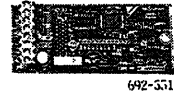

PG SPEED CONTROL CARD PG-C

Simultaneous read and write of constants

Set values can be copied by one touch control with the constant copy unit.

Remote controlled operation

Operation can be controlled at the machine side (within 3m) or from a remote control panel (within 100m).

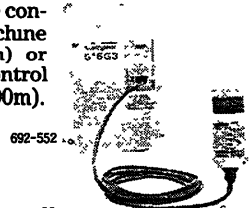

A variety of options

The frequency input options and output monitoring options allow high-precision control and monitoring.

- Frequency reference option cards:
 - High-precision analog input
 - AI-14U (14 bits)
 - AI-14B (13 bits with direction)
 - General-purpose digital input
 - DI-08 (two BCD digits or eight binary bits)
 - DI-16G (four BCD digits or sixteen binary bits)
- Monitoring option card
 - Analog monitor
 - A0-08 (0-10VDC, 8 bits, 2-point output)
 - A0-12 (0-10VDC, 12 bits, 2-point output)
 - Pulse monitor PO-36F (1F, 6F, 10F, 12F, 36F, +12V)
 - Digital output
 - DO-08 (2 contacts, 6 open-collectors).

ADVANCED LEVEL MOTOR DRIVE

Conventional Weak Points Have been Overcome to Achieve Top Motor Performance

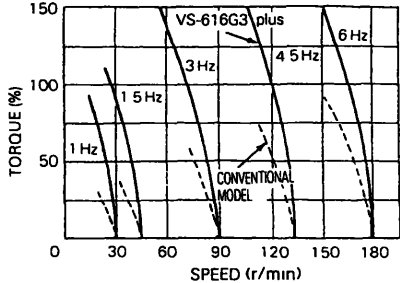
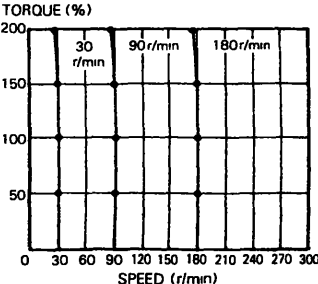
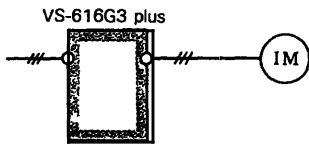
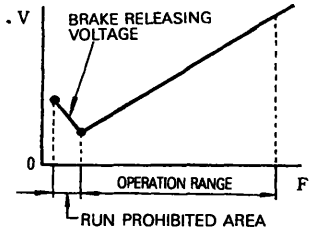
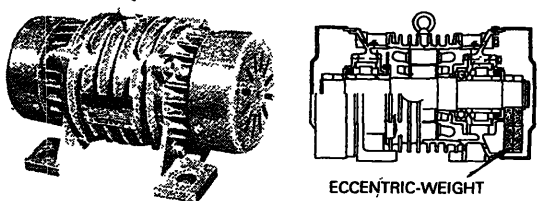
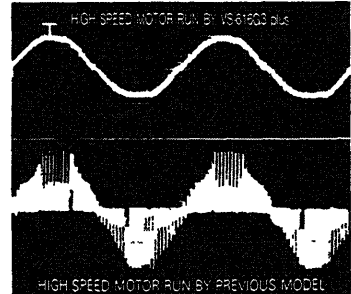
Conventional Inverter Shortcomings	VS-616G3 plus Solutions
<p>Low starting torque. Inverter of the next higher capacity must be employed for applications requiring high starting torque.</p>	<p>150% torque established at 1/20 of the rated speed. Motor torque increases up to 150% over full-speed range due current waveform correction by asynchronous PWM method and automatic torque compensation by vector control operation.</p>  <p>150% min. torque assured at 1Hz Voltage-type vector control combined with Yaskawa standard motor achieves strong low-speed torque.</p> 
<p>Typical Problem: Cannot vary speeds of the excitation release type motor with a brake.</p>	<p>Easily starts motor with a brake. The brake can be securely tripped.</p>   <p>V/f can be changed arbitrarily.</p>
<p>Difficult to vary speeds of the vibration type URAS motor. Inverter of one or two classes greater capacity is applied for the eccentric weight incompensating type motor. YASKAWA URAS Motor</p>	<p>Automatic torque boost effectively solves the eccentric torque problem. Inverter of the same capacity as the motor can be used for cost-savings.</p> 
<p>Frequent overcurrent when starting a high frequency motor. Because of very low inductance of a high frequency motor, ripple current tends to be high and overcurrent may frequently occur. To compensate for this, an inverter of one or two classes greater capacity and output AC reactor is normally used.</p>	<p>Original, asynchronous, high-carrier frequency, PWM technique improves the motor characteristics. This eliminates the need for an AC reactor to reduce ripple current.</p> 

Significantly Enhanced Speed Control Stability

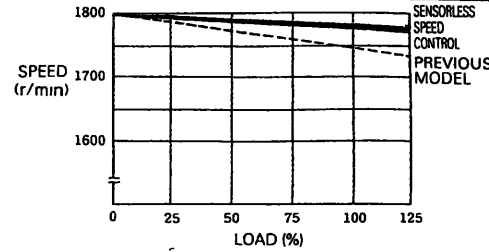
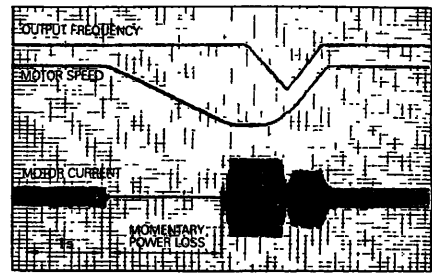
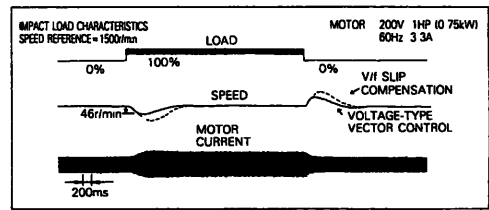
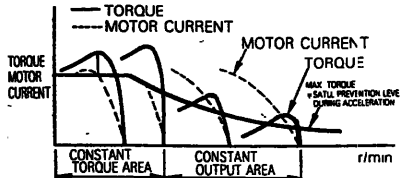
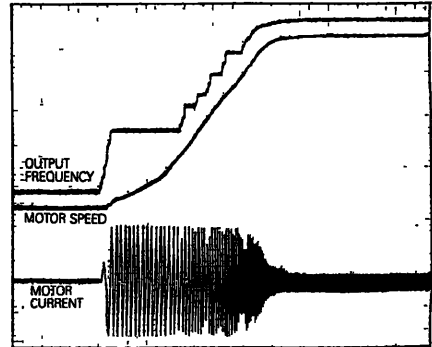
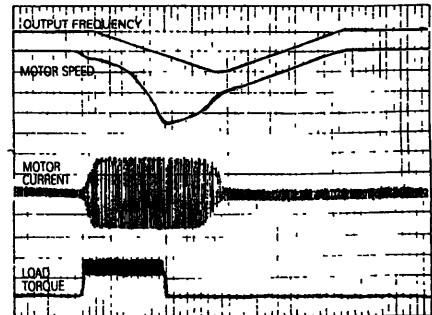
Conventional Inverter Shortcomings	VS-616G3 plus Solutions
<p>Motor speed control cannot be improved beyond the VS-616G3's performance without using PG or TG feedback. (closed-loop)</p>	<p>Built-in sensorless speed control function reduces speed fluctuations to 1/3 to 1/5 of rated speed.</p> <p>Precisely calculates load from motor current and corrects slip.</p> <p>For precise slip correction by this function, motor rated current, no load current, and rated slip are required</p> <p>For high-precision operation, use motor with PG speed control card PG-C/PG-D.</p> 
<p>Operation cannot continue after momentary power loss.</p>	<p>Continues operation during a momentary power loss of less than 2 seconds.</p>  <p>OPERATION CONTINUATION AFTER MOMENTARY POWER LOSS</p>
<p>Cannot follow up for load variations.</p>	<p>Quick response to load variations</p> <p>The voltage-type vector control responds three times better than that of V/f control. It also operates strongly during disturbance.</p> 
<p>Hard to adjust starting time.</p> <p>Setting a shorter time than that determined by motor torque and load Wk (GD²) may cause acceleration failure resulting in OC or overcurrent. Or it may cause an acceleration failure and falling in rated output area.</p>	<p>Stall prevention during acceleration</p> <p>Automatically adjusts the acceleration rate according to the current of the accelerating motor to prevent stalling or overcurrent condition.</p>  <p>Motor accelerates at max torque value in constant output area.</p>  <p>STALL PREVENTION DURING ACCELERATION</p>
<p>Stall by overload in operation.</p> <p>Momentary overload condition during inverter operation causes 'pull-out' condition, resulting in motor torque reduction operation failure due to overcurrent or overload protection activation.</p>	<p>Stall prevention during operation</p> <p>If overloaded during operation, automatically reduces frequency. In this case, motor outputs the maximum torque. When the load returns to normal, frequency accelerates to the previous set value and operation continues.</p>  <p>STALL PREVENTION DURING OPERATION</p>

Vast Application Experience is Inco

The VS-616G3 flexible inverter incorporates a variety of application know-how. Select special functions from a multitude of possibilities to perfectly match your machine.

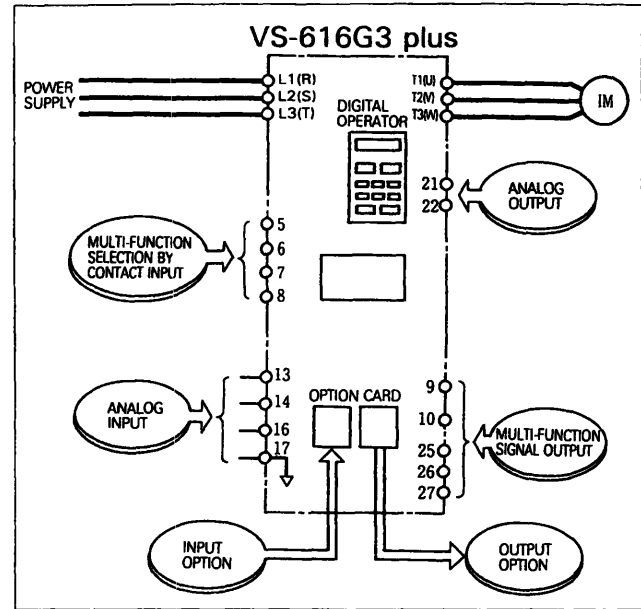

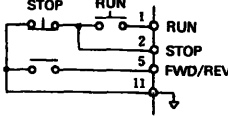
Function name	Target market	Application	Operation, advantages	VS - 616G3 plus setting			
				Contact setting	Analog I/O	Signal output	Control constant setting
Speed search operation	Inertia load drive such as blower, winder, etc	Synchronize with the coasting motor	Starts the inverter at the specified frequency, automatically detects the synchronization point, and leads the operation to the operation frequency. No speed detector is required. It is no longer necessary to stop the motor before starting, the operation efficiency for the customer is greatly improved.	●			Sn-15 to 18
DC injection braking before operation	Blower, pump, etc which have wind-mill effects	Starting the free running motor	When the direction of the free running motor is unfixed, the above speed search operation function is difficult to use. In these, the motor can be stopped by DC injection braking, and be restarted by the inverter. The operation is completely automatic.	●			Sn-15 to 18 Cn-11 Cn-13
Commercial power source / inverter switchover operation	Blower, pump, mixer, extruder, etc	Automatic switching between commercial power source and inverter	Switching of commercial power source to inverter or inverter to commercial power source is done without stopping the motor. The operation efficiency for the customer is improved. When the inverter size is decided by the starting capacity (as in the extruder), this function can be used to reduce the inverter capacity.	●			Sn-15 to 18
Energy saving operation	Precision machine tool	Energy saving, Low vibration	Full power is output during accel / decel. When it reaches a constant speed, the output voltage is automatically reduced to the preset value. Mainly applied to reduce the vibration in precision machine tools.	●			Sn-15 to 18 bn-09
Multi-step speed operation	Transportation machine, etc	Schedule operation under fixed speed command and positioning stop	Multi-stop operation can be set by setting the contact combinations, so the connection with PLC becomes very easy. When combined with jog speed can also allow simple positioning.	●			Sn-15 to 18 An-01 to 09
Accel / decel time changeover operation	Machine tool, etc	The accel / decel time changeover with an external signal	The two kinds of accel / decel times are switched by an external contact signal. Necessary for switching operation of 2 machines with different functions by a single inverter. Also used in emergency stopping applications.	●			Sn-15 to 18 bn-01, 02 bn-03, 04
Inverter overheat prediction	Air conditioner, etc	Preventive maintenance	When the ambient temperature of the inverter rises to within 10°C of the maximum allowable temperature, warning is given. Motor keeps running.	●			Sn-15 to 18
3-wire sequence	General	Simple configuration of control circuit	Operation can be accomplished using a momentary push-button switch. 	●			Sn-15 to 18
Operating site selection	General	Easy operation	Operation and settings can be selected while the inverter is online (digital operator / external instruction, signal input / output).	●			Sn-04 Sn-15 to 18
Frequency hold * operation	General	Easy operation	Temporary stops change of frequencies during acceleration or deceleration.	●			Sn-15 to 18
Fault trip retry operation	Air conditioner, etc	Improvement of operation reliability	When the inverter trips, it first begins to coast, and then it immediately is diagnosed by computer, resets automatically, and returns to the original operation speed by speed search operation. Up to 10 retry counts can be selected.				Sn-11 Cn-36
Quick stop without braking resistor (DC injection braking stop)	High-speed router, etc	DC injection braking of induction motor	DC injection braking is performed from top speed. The duty is 5% or less. Can generate 50% to 70% of the braking torque. Economic, because a braking resistor is not necessary. Has advantage of mounting in completely closed cabinets.				Sn-04 Cn-11 Cn-12

* Contact your Yaskawa representative for availability in North American markets.

porated in the Software Functions

Function name	Target market	Application	Operation, advantages	VS - 616G3 plus setting			
				Contact Input	Analog I/O	Signal output	Control constant setting
Excess torque detect setting operation	Blower, cutter, extruder, etc	<ul style="list-style-type: none"> Protection of machine Improvement of continuous operation reliability Torque limit 	The inverter can be switched to coasting or motor speed reducing mode as soon as it reaches a certain preset torque level. Machine (especially cutter) protection can be done without using special peripheral devices. When used in a blower application the operation frequency can be automatically reduced to the load balancing point, according to the overload condition, and prevent overload tripping.			●	Sn-07, 10 Cn-26, 27 Cn-30
Upper / lower frequency limit operation	Pump, blower	Motor speed limit	The upper and lower limits of the motor speed can be set independently. No peripheral operation units. The command signal bias and gain can also be set independently.				Cn-14, 15
Prohibit setting of specific frequency (frequency jump control)	General machines	Prevent mechanical vibration in the equipment	The motor simply passes through the preset speed, and continuous running cannot be done at this speed. This function is used to avoid the mechanical resonance point of the equipment. (Up to 3 points can be set.)				Cn-16 to 19
Carrier frequency setting	General machines	Lower noise, eliminates resonance	The carrier frequency can be set to reduce the acoustic noise from the motor and machine system.				Cn-23 to 25
Automatic continuous operation when the speed command is lost	Air conditioner	Improving reliability of continuous operation	When the frequency command signal is lost, operation is automatically continued at the pre-programmed speed. (Countermeasures to the failure of host computer.) This function is important for air conditioning systems in "intelligent buildings."				Sn-06
Load speed display	General	Monitor function enhancement	Can indicate motor speed (r/min), machine speed loaded (r/min), line speed (m/min), etc.				Cn-20
Run signal	General	Motor with mechanical brake operation	"Closed" during operation. "Open" during coasting to a stop. Can be used as interlock contact point during stop.			●	Sn-20 to 22
Zero-speed signal	Machine tools	Zero-frequency interlock	Can be used as tool exchange signal.			●	Sn-20 to 22
Speed agreed signal	Machine tools	Command speed reach interlock	The contact closes when inverter output frequency reaches the set value. Can be used as an interlock for lathes, etc.			●	Sn-20 to 22
Excess torque signal	Blower, cutter, extruder, etc	Protection of machine, improvement of operation continuation reliability	Works when "overtorque setting operation" is accomplished. Can be used as a torque limiter.			●	Sn-07 Sn-20 to 22 Cn-26, 27
Low voltage signal	General	System protection for undervoltage	This contact is "closed" only when tripped by low voltage. Can be used as power loss detection relay for the system power loss countermeasure.			●	Sn-20 to 22
Free unintentionally speed agreed signal	General	Command speed agreed interlock	The contact closes when the speed agrees at arbitrary frequency command.			●	Cn-21, 22
Output frequency detection 1	General	Gear change interlock etc	The contact closes at an arbitrary output frequency and above.			●	Sn-20 to 22 Cn-21, 22
Output frequency detection 2	General	Gear change interlock etc	The contact closes at the arbitrary output frequency and below.			●	Sn-20 to 22 Cn-21, 22
Base block signal	General	Operation interlock, etc	Always "close" when the inverter output is off.			●	Sn-20 to 22
Damping resistor protection	General	Preventive maintenance	"Close" when an overheat of a built-in braking resistor or a braking transistor error is detected.			●	Sn-11
Frequency reference sudden change detection	General	Operation stability	"Close" when the frequency reference suddenly drops to 10% or below of the set value.			●	Sn-20 to 22 Sn-06
Analog input signal	General	Easy operation	Functions as supplementary frequency reference. Also used for fine control of input reference, output voltage adjustment, external control of accel / decel time, and fine adjustment of overtorque detection level.		●		Sn-19
Analog output signal	General	Monitor function enhancement	Either a frequency meter, ammeter, voltmeter, or wattmeter can be used.		●		Sn-05
Analog input	General	Easy operation	Enables external operation with high resolution instructions. Also enables normal and reverse operation using positive or negative voltage signals.				Sn-25
Digital input	General	Easy operation	Enables operation with 8-bit or 16-bit digital signals. Easily connects to NC or PC (DI-08, DI-16G).				Sn-26
Analog output	General	Monitor function enhancement	Monitors output frequency, motor current, output voltage, and DC voltage (AO-08, AO-12).				Sn-28
Digital output	General	Operation enhancement	Indicates output frequency using a pulse counter. Indicates errors through discrete output (PO-36F).				Sn-27

EXCELLENT SPECIFICATIONS FOR EASY OPERATION

SPECIFICATIONS 200 to 230V

Inverter Model CIMR - G3□		Low Noise Type										Compact Low-carrier Frequency Type					
		20P4	20P7	21P5	22P2	23P7	25P5	27P5	2011	2015	2018	2022	2030	2037	2045	2055	2075
Max. Applicable Motor Output*1 HP (kW)		0.5 (0.4)	1 (0.75)	2 (1.5)	3 (2.2)	5 (3.7)	7.5 (5.5)	10 (7.5)	15 (11)	20 (15)	25 (18.5)	30 (22)	40 (30)	50 (37)	60 (45)	75 (55)	100 (75)
Output Charac- teristics	Inverter Capacity kVA	1.4	2.1	2.7	4.1	6.9	10.3	13.7	20.6	27.4	34	41	54	68	78	95	130
	Rated Current A	3.2	4.8	6.4	9.6	16	24	32	48	64	80	96	130	160	183	224	300
	Max. Continuous Current*2 A	3.6	5.4	7.2	10.8	18	27	36	54	72	90	108	146	180	205	252	337
	Max. Voltage	3-Phase, 200/208/220/230V (Proportional to input voltage)															
	Rated Frequency	50, 60, 72, 90, 120, 180 Hz (up to 400 Hz available)															
Power Supply	Rated Input Voltage and Frequency	3-Phase 200/208/220V, 50 Hz 200/208/220/230V, 60 Hz															
	Allowable Voltage Fluctuation	± 10%															
	Allowable Frequency Fluctuation	± 5%															
	Control Method	Sine wave PWM (V/f control or encoder-less voltage-type) ^{*3} vector control using exclusive ROM															
Control Charac- teristics	Frequency Control Range	0.1 to 400 Hz															
	Frequency Accuracy	Digital command: 0.01% (+14 to 104°F / -10 to 40°C) Analog command: 0.1% (77 ± 18°F / 25 ± 10°C)															
	Frequency Setting Resolution	Digital operator reference: 0.01 Hz (when less than 100 Hz), 0.1 Hz (when 100 Hz or more) Analog reference: 0.06 Hz/60 Hz															
	Output Frequency Resolution	0.01 Hz (1/30000)															
	Overload Capacity	150% rated output current for one minute															
	Frequency Setting Signal	0 to 10 VDC (20 kΩ), 4 to 20 mA (250 Ω) 0 to ±10V (OPTIONAL)															
	Accel/Decel Time	0.1 to 6000 sec (Accel/Decel time setting independently)															
	Braking Torque	Approx. 20%															
	No. of V-f Patterns (Total of 15)	4: For general purpose 4: For high starting torque 4: For fans and pumps 3: For machine tools															
	Motor Overload Protection	Electronic thermal overload relay															
	Protec- tive Func- tions	Instantaneous Overcurrent	Motor coasts to a stop at approx 200% rated output current.														
Blown Fuse Protection		Motor coasts to a stop by blown-fuse.															
Overload		Motor coasts to a stop after 1 minute at 150% rated output current.															
Overvoltage		Motor coasts to a stop if converter output voltage exceeds 400V.															
Undervoltage		Motor coasts to a stop if converter output voltage drops to 210V or below.															
Momentary Power Loss		Immediately stop by 15 ms and above longer power loss (Continuous system operation during power loss less than 2 sec is equipped as standard.) ^{*4} Setting mode before shipment.															
Fin Overheat		Thermostat															
Cooling Fan Fault		Fan sensor for inverters of more than 40HP (30kW)															
Stall Prevention		Stall prevention during acceleration/deceleration and constant speed operation															
Ground Fault		Provided by electronic circuit															
Power Charge Indication		Charge lamp stays ON until bus voltage drops below 50V.															
Environ- mental Condi- tions	Location	Indoor (protected from corrosive gases and dust)															
	Ambient Temperature	+14 to 104°F (-10 to +40°C) for enclosed wall-mounted type and water and dust tight type ^{*5} (not frozen) +14 to 122°F (-10 to +50°C) for open chassis type															
	Storage Temperature*6	-4 to 140°F (-20 to +60°C)															
	Humidity	90% RH (non condensing)															
	Vibration	9.8m/s ² (1G) at 10 to 20Hz, up to 1.96m/s ² (0.2G) at 20 to 55Hz															

*1 Our standard 4-pole motor is used for max applicable motor output.

*2 Allowable values for applications not requiring overload

*3 Encoder-less voltage-type vector control corresponds to inverter models CIMR-G320P4 to -G32022

*4 For Models of 3 HP (2.2kW) or less, continuous system operation during momentary power loss less than 1 sec
Two-seconds ride-thru available as option

*5 For water and dust tight type (NEMA4), models of 3 HP to 10 HP (2.2kW to 7.5kW) are available.

*6 Temperature during shipping (for short period)

SPECIFICATIONS 380 to 460V

Inverter Model CIMR - G3□		Low Noise Type																	Compact Low-carrier Frequency Type					
		40P4	40P7	41P5	42P2	43P7	45P5	47P5	4011	4015	4018	4022	4030	4037	4L45 ^{*3}	4L55	4L75	4LA1	4LA6	4045 ^{*3}	4185	4220	4300	
Max. Applicable Motor Output*1 HP (kW)		0.5 (0.4)	1 (0.75)	2 (1.5)	3 (2.2)	5 (3.7)	7.5 (5.5)	10 (7.5)	15 (11)	20 (15)	25 (18.5)	30 (22)	40 (30)	50 (37)	60 (45)	75 (55)	100 (75)	150 (110)	200 (160)	60 (45)	250 (185)	300 (220)	400 (300)	
Output Characteristics	Inverter Capacity kVA	1.4	2.2	3.4	4.1	6.9	10.3	13.7	20.6	27.4	34	41	54	68	82	110	140	200	250	82	290	380	510	
	Rated Current A	1.6	2.6	4.0	4.8	8	12	16	24	32	40	48	64	80	96	128	165	224	300	96	340	450	600	
	Max. Continuous Current*2 A	1.8	2.9	4.5	5.4	9	13.5	18	27	36	45	54	72	90	108	144	180	252	337	108	380	506	675	
	Max. Voltage	3-Phase, 380/400/415/440/460V (Proportional to input voltage)																						
	Rated Frequency	50, 60, 72, 90, 120, 180 Hz (up to 400 Hz available)																						
Power Supply	Rated Input Voltage and Frequency	3-Phase 380/400/415/440/460V, 50/60Hz																						
	Allowable Voltage Fluctuation	± 10%																						
	Allowable Frequency Fluctuation	± 5%																						
Control Characteristics	Control Method	Sine wave PWM (V/f control or encoder-less voltage-type vector control using exclusive ROM) ^{*4}																						
	Frequency Control Range	0.1 to 400 Hz																						
	Frequency Accuracy	Digital command: 0.01% (+14 to 104°F / -10 to 40°C) Analog command: 0.1% (77 ± 18°F / 25 ± 10°C)																						
	Frequency Setting Resolution	Digital operator reference: 0.01 Hz (when less than 100 Hz), 0.1 Hz (when 100 Hz or more) Analog reference: 0.06 Hz/60 Hz																						
	Output Frequency Resolution	0.01 Hz (1/30000)																						
	Overload Capacity	150% rated output current for one minute																						
	Frequency Setting Signal	0 to 10 VDC (20 kΩ), 4 to 20 mA (250 Ω) 0 to ± 10V (OPTIONAL)																						
	Accel/Decel Time	0.1 to 6000 sec (Accel/Decel time setting independently)																						
	Braking Torque	Approx. 20%																						
	No. of V-f Patterns (Total of 15)	4: For general purpose 4: For high starting torque 4: For fans and pumps 3: For machine tools																						
	Protective Functions	Motor Overload Protection	Electronic thermal overload relay																					
		Instantaneous Overcurrent	Motor coasts to a stop at approx. 200% rated output current.																					
Blown Fuse Protection		Motor coasts to a stop by blown-fuse.																						
Overload		Motor coasts to a stop after 1 minute at 150% rated output current.																						
Overvoltage		Motor coasts to a stop if converter output voltage exceeds 800V (700V). ^{*5}																						
Undervoltage		Motor coasts to a stop if converter output voltage drops to 420V or below.																						
Momentary Power Loss		Immediately stop by 15 ms and above longer power loss. (Continuous system operation during power loss less than 2 sec is equipped as standard). ^{*6} Setting mode before shipment.																						
Fin Overheat		Thermostat																						
Cooling Fan Fault		Fan sensor for inverters of more than 75HP (55kW)																						
Stall Prevention		Stall prevention during acceleration/deceleration and constant speed operation																						
Ground Fault		Provided by electronic circuit																						
Power Charge Indication		Charge lamp stays ON until bus voltage drops below 50V.																						
Environmental Conditions		Location	Indoor (protected from corrosive gases and dust)																					
		Ambient Temperature	+14 to 104°F (-10 to +40°C) for enclosed wall-mounted type and water and dust tight type ^{*7} (not frozen) +14 to 122°F (-10 to +50°C) for open chassis type																					
	Storage Temperature*8	-4 to 140°F (-20 to +60°C)																						
	Humidity	90% RH (non-condensing)																						
	Vibration	9.8m/s ² (1G) at 10 to 20Hz, up to 1.96m/s ² (0.2G) at 20 to 55Hz																						

*1 Our standard 4-pole motor is used for max applicable motor output

*2 Allowable values for applications not requiring overload.

*3 Both low noise type model-4L45 and compact low-carrier frequency type model-4045 are available for inverter of max applicable motor output 60Hz (45kW)

*4 Encoder-less voltage-type vector control corresponds to inverter models CIMR-G340P4 to G34L45.

*5 800V for input voltage (Cn-01) more than 400V and 700V for less than 400V.

*6 For Models of 3 HP (2.2kW) or less, continuous system operation during momentary power loss less than 1 sec.

Two-seconds ride-thru available as option

*7 For water and dust tight type (NEMA4), models of 3 HP to 10 HP (2.2kW to 7.5 kW) are available

*8 Temperature during shipping (for short period)

SPECIFICATIONS (500 to 600V)

Inverter Model CIMR - G3□		Low Noise Type													Compact Low-carrier Frequency Type			
		51P5	52P2	53P7	55P5	57P5	5011	5015	5018	5022	5030	5037	5045	5055	5075	5090	5110	5160
Max. Applicable Motor Output*1 Hp (kW)		2 (1.5)	3 (2.2)	5 (3.7)	7.5 (5.5)	10 (7.5)	15 (11)	20 (15)	25 (18.5)	30 (22)	40 (30)	50 (37)	60 (45)	75 (55)	100 (75)	120 (90)	150 (110)	200 (160)
Output Characteristics	Inverter Capacity kVA	2	3	5	7.5	10	15	20	25	30	40	50	60	75	100	125	150	200
	Rated Current A	3.5	4.1	6.3	9.8	12.5	17	22	27	32	41	52	62	77	99	130	172	200
	Max. Continuous Current*2 A	3.9	4.6	7	11.0	14	19	25	30	36	46	58	69	86	111	145	192	224
	Max. Voltage	3-Phase, 500/600V (Proportional to input voltage)																
	Rated Frequency	50, 60, 72, 90, 120, 180 Hz (up to 400 Hz available)																
Power Supply	Rated Input Voltage and Frequency	3-Phase 500/575/600V, 50/60 Hz																
	Allowable Voltage Fluctuation	±10%																
	Allowable Frequency Fluctuation	±5%																
Control Characteristics	Control Method	Sine wave PWM																
	Frequency Control Range	0.1 to 400 Hz																
	Frequency Accuracy	Digital command: 0.01% $\left(\begin{matrix} +14 \text{ to } 104^{\circ}\text{F} \\ -10 \text{ to } 40^{\circ}\text{C} \end{matrix} \right)$ Analog command: 0.1% $\left(\begin{matrix} 77 \pm 18^{\circ}\text{F} \\ 25 \pm 10^{\circ}\text{C} \end{matrix} \right)$																
	Frequency Setting Resolution	Digital operator reference: 0.01 Hz (when less than 100 Hz), 0.1 Hz (when 100 Hz or more) Analog reference: 0.06 Hz/60 Hz																
	Output Frequency Resolution	0.01 Hz (1/30000)																
	Overload Capacity	150% rated output current for one minute																
	Frequency Setting Signal	0 to 10 VDC (20 kΩ), 4 to 20 mA (250 Ω) 0 to ±10V (OPTIONAL)																
	Accel/Decel Time	0.1 to 6000 sec (Accel/Decel time setting independently)																
	Braking Torque	Approx. 20%																
	No. of V-f Patterns (Total of 15)	4: For general purpose 4: For high starting torque 4: For fans and pumps 3: For machine tools																
Protective Functions	Motor Overload Protection	Electronic thermal overload relay																
	Instantaneous Overcurrent	Motor coasts to a stop at approx. 200% rated current.																
	Blown Fuse Protection	Motor coasts to a stop by blown-fuse.																
	Overload	Motor coasts to a stop after 1 minute at 150% rated output current.																
	Overvoltage	Motor coasts to a stop if converter output voltage exceeds 1040V (910V).*3																
	Undervoltage	Motor coasts to a stop if converter output voltage drops to 546V or below.																
	Momentary Power Loss	Immediately stop by 15 ms and above longer power loss. (Continuous system operation during power loss less than 2 sec is equipped as standard.) *4 Setting mode before shipment.																
	Fin Overheat	Thermostat																
	Cooling Fan Fault	Fan sensor for inverter of more than 30HP (22kW)																
	Stall Prevention	Stall prevention at acceleration/deceleration and constant speed operation																
	Ground Fault	Provided by electronic circuit																
	Power Charge Indication	Charge lamp stays ON until bus voltage drops below 50V.																
	Environmental Conditions	Location	Indoor (protected from corrosive gases and dust)															
Ambient Temperature		+14 to 104°F (-10 to +40°C) for enclosed wall-mounted type (not frozen) +14 to 122°F (-10 to +50°C) for open chassis type (not frozen)																
Storage Temperature*5		-4 to 140°F (-20 to +60°C)																
Humidity		90% RH (non-condensing)																
Vibration	9.8m/s ² (1G) at 10 to 20Hz, up to 1.96m/s ² (0.2G) at 20 to 55Hz																	

*1 Our standard 4-pole motor is used for max applicable motor output.

*2 Allowable values for applications not requiring overload.

*3 1040V for input voltage (Cn-01) more than 500V and 910V for less than 500V.

*4 For Models of 3HP (2.2kW) or less, continuous system operation during momentary power loss less than 1 sec. Two-second ride-thru available as option.

*5 Temperature during shipping (for short period)

RELIABLE PROTECTIVE ENCLOSURES

Voltage	Max Applicable Motor Output HP (KW)	VS-616G3 plus		Enclosures (Specify the enclosure type when ordering)			
		Capacity kVA	Model	Open Chassis Type (IEC IP00)	Enclosed Type (NEMA 1)	Water and Dust Tight Type (NEMA 4)	
200 to 230V	0.5 (0.4)	1.4	CIMR-G3U20P4	Available by removing the upper and lower cover of enclosed type	2 0P41	-	
	1 (0.75)	2.1	CIMR-G3U20P7		2 0P71		
	2 (1.5)	2.7	CIMR-G3U21P5		2 1P51		
	3 (2.2)	4.1	CIMR-G3U22P2		2 2P21		22P28
	5 (3.7)	6.9	CIMR-G3U23P7		2 3P71		23P78
	7.5 (5.5)	10.3	CIMR-G3U25P5		2 5P51		25P58
	10 (7.5)	13.7	CIMR-G3U27P5		2 7P51		27P58
	15 (11)	20.6	CIMR-G3U2011		2011		2 0111
	20 (15)	27.4	CIMR-G3U2015		2015		2 0151
	25 (18.5)	34	CIMR-G3U2018		2018		2 0181
	30 (22)	41	CIMR-G3U2022		2022		2 0221
	40 (30)	54	CIMR-G3U2030		2030		-
	50 (37)	68	CIMR-G3U2037		2037		-
	60 (45)	78	CIMR-G3U2045		2045		-
75 (55)	95	CIMR-G3U2055	2055	-			
100 (75)	130	CIMR-G3U2075	2075	-			
380 to 460V	0.5 (0.4)	1.4	CIMR-G3U40P4	Available by removing the upper and lower cover of enclosed type	4 0P41	-	
	1 (0.75)	2.2	CIMR-G3U40P7		4 0P71		
	2 (1.5)	3.4	CIMR-G3U41P5		4 1P51		
	3 (2.2)	4.1	CIMR-G3U42P2		4 2P21		42P28
	5 (3.7)	6.9	CIMR-G3U43P7		4 3P71		43P78
	7.5 (5.5)	10.3	CIMR-G3U45P5		4 5P51		45P58
	10 (7.5)	13.7	CIMR-G3U47P5		4 7P51		47P58
	15 (11)	20.6	CIMR-G3U4011		4011		4 0111
	20 (15)	27.4	CIMR-G3U4015		4015		4 0151
	25 (18.5)	34	CIMR-G3U4018		4018		4 0181
	30 (22)	41	CIMR-G3U4022		4022		4 0221
	40 (30)	54	CIMR-G3U4030		4030		4 0301
	50 (37)	68	CIMR-G3U4037		4037		4 0371
	60 (45) ^{Note}	82	CIMR-G3U4L45		4L45		4 L451
			CIMR-G3U4045		4045		4 0451
	75 (55)	110	CIMR-G3U4L55		4L55		4 L551
	100 (75)	140	CIMR-G3U4L75		4L75		4 L751
	150 (110)	200	CIMR-G3U4LA1		4LA1		4 LA11
	200 (160)	250	CIMR-G3U4LA6		4LA6		4 LA61
	250 (185)	290	CIMR-G3U4185		4185		-
300 (220)	380	CIMR-G3U4220	4220	-			
400 (300)	510	CIMR-G3U4300	4300	-			

Note The upper column indicates low noise type
The lower column indicates compact low-carrier frequency type

- Delivered immediately
- Stocked at factory
- Manufactured upon order

ENCLOSURES

Open Chassis Type (IEC IP00)

Mounted in a customer's enclosure. Constructed so that openings do not permit direct or inadvertent access to live parts by personnel.

Enclosed Type (NEMA 1/IEC IP20)

Provides a clean, and ventilated environment within the enclosure. Front and rear panels are firmly secured (e.g. front, rear, right, left, top, bottom). Openings provided for ventilation, etc. are small enough to prevent inadvertent access by personnel.

Water and Dust Tight Type (NEMA 4/IEC IP56)

Prevents entry of dust, direct water spray or splashes from any direction.

MODEL DESIGNATION

CIMR - G3 2 0P7

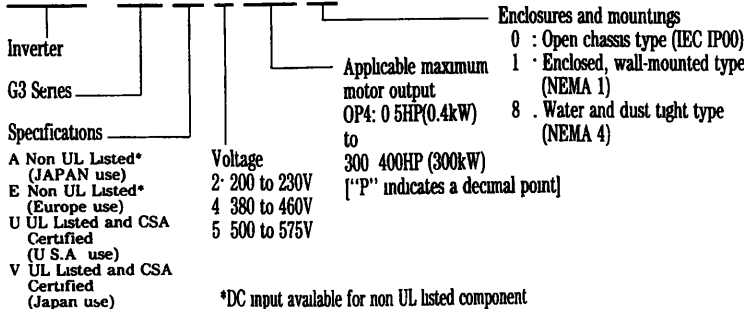

SPEC. NP EXAMPLE

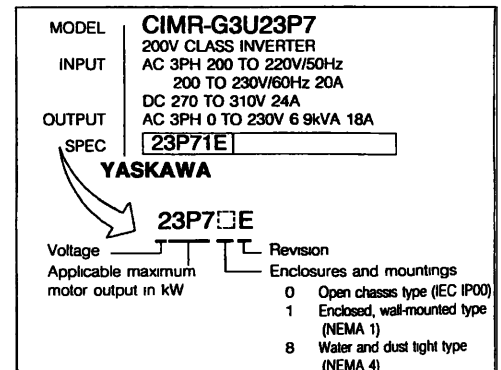

Mounting Dimensions in inch (mm)

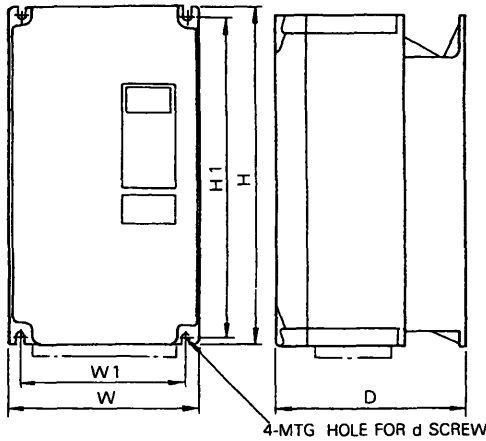

- Notes 1. The above dimensions show model CIMR-G3□27P51.
 2. Remove the upper and lower covers of the enclosed type units for [] area

- * For more than 30HP (22kW), contact your YASKAWA representative.
 † Mounting dimensions for 400V class, 250 to 400 HP (185 to 300kW) are as follows:

• Mounting Dimensions for 400V Class, 250 to 400HP (185 to 300kW)

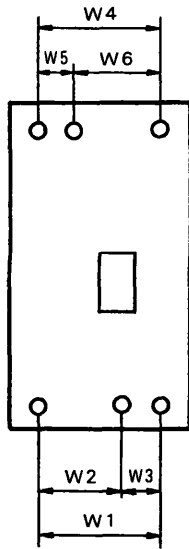

Model (CIMR-G3□□□□)	Dimensions in inch (mm)					
	W1	W2	W3	W4	W5	W6
4185, 4220	29.53 (750)	17.32 (440)	12.20 (310)	33.46 (850)	11.22 (285)	22.24 (565)
4300	29.53 (750)	17.32 (440)	12.20 (310)	34.37 (873)	11.73 (298)	22.64 (575)

† These models have built-in DC reactors to reduce the number of harmonic components for input current.

Voltage V	Enclosure	Model (CIMR-G3□□□□)	Dimensions in inch (mm)						Mass lb (kg)	
			W	H	D	W1	H1	d		
200 to 230	Open chassis type	20P4, 20P7, 21P5	8.05 (204.5)	11.97 (304)	5.12 (130)	7.09 (180)	11.22 (285)	M6	9 (4)	
		22P2, 23P7	8.05 (204.5)	11.97 (304)	6.50 (165)	7.09 (180)	11.22 (285)	M6	15 (7)	
		25P5, 27P5	8.05 (204.5)	13.94 (354)	7.87 (200)	7.09 (180)	13.19 (335)	M6	22 (10)	
		2011	9.84 (250)	19.69 (500)	9.45 (240)	7.87 (200)	19.09 (485)	M6	42 (19)	
		2015	12.79 (325)	21.65 (550)	9.65 (245)	10.83 (275)	21.06 (535)	M6	51 (24)	
		2018, 2022	12.79 (325)	21.65 (550)	10.04 (255)	10.83 (275)	21.06 (535)	M6	70 (32)	
		2030	16.73 (425)	26.57 (675)	11.02 (280)	12.40 (315)	25.79 (655)	M8	112 (51)	
		2037	18.70 (475)	31.50 (800)	11.02 (280)	14.76 (375)	30.71 (780)	M10	130 (59)	
		2045, 2055	18.70 (475)	31.50 (800)	11.02 (280)	14.76 (375)	30.71 (780)	M10	143 (65)	
		2075	23.62 (600)	50.39 (1280)	17.83 (453)	21.65 (550)	49.02 (1245)	M12	317 (143)	
	Enclosed wall- mounted type (NEMA1)	20P41, 20P71, 21P51	8.05 (204.5)	11.97 (304)	5.12 (130)	7.09 (180)	11.22 (285)	M6	9 (4)	
		22P21, 23P71	8.05 (204.5)	11.97 (304)	6.50 (165)	7.09 (180)	11.22 (285)	M6	15 (7)	
		25P51, 27P51	8.05 (204.5)	13.94 (354)	7.87 (200)	7.09 (180)	13.19 (335)	M6	22 (10)	
		20111	11.81 (300)	23.62 (600)	9.65 (245)	11.02 (280)	19.69 (500)	M6	57 (26)	
		20151	14.76 (375)	25.59 (650)	9.84 (250)	13.98 (355)	21.65 (550)	M6	71 (32)	
		20181	18.50 (470)	27.56 (700)	10.24 (260)	17.52 (445)	23.62 (600)	M8	95 (43)	
	20221	18.50 (470)	29.13 (740)	10.24 (260)	17.52 (445)	23.62 (600)	M8	95 (43)		
	Water and dust tight type (NEMA4)	22P2, 23P7, 25P5, 27P5	8.29 (210.5)	16.3 (413)	7.89 (200.5)	7.09 (180)	14.0 (355)	M6	26.5 (12)	
	380 to 460	Open chassis type	40P4, 40P7, 41P5, 42P2	8.05 (204.5)	13.94 (354)	6.50 (165)	7.09 (180)	13.19 (335)	M6	15 (7)
			43P7, 45P5, 47P5	8.05 (204.5)	13.94 (354)	7.87 (200)	7.09 (180)	13.19 (335)	M6	22 (10)
4011, 4015			9.84 (250)	19.69 (500)	10.04 (255)	7.87 (200)	19.09 (485)	M6	48 (22)	
4018, 4022			12.79 (325)	21.65 (550)	10.04 (255)	10.43 (265)	21.06 (535)	M6	70 (32)	
4030, 4037, 4045			13.78 (350)	28.54 (725)	11.02 (280)	9.84 (250)	27.76 (705)	M8	99 (45)	
4L45			19.69 (500)	36.42 (925)	11.02 (280)	15.75 (400)	35.43 (900)	M10	161 (73)	
4L55†			17.91 (455)	32.28 (820)	12.99 (330)	13.78 (350)	31.30 (795)	M10	190 (86)	
4L75†			17.91 (455)	32.28 (820)	12.99 (330)	13.78 (350)	31.30 (795)	M10	190 (86)	
4LA1†			22.64 (575)	36.42 (925)	13.98 (355)	17.52 (445)	35.24 (895)	M12	291 (132)	
4LA6†			22.64 (575)	36.42 (925)	14.96 (380)	17.52 (445)	35.24 (895)	M12	322 (146)	
4185, 4220		37.40 (950)	57.09 (1450)	17.13 (435)	†	55.12 (1400)	M12	794 (360)		
4300		37.80 (960)	62.99 (1600)	17.91 (455)	†	61.02 (1550)	M12	926 (420)		
Enclosed wall- mounted type (NEMA1)		40P41, 40P71, 41P51, 42P21	8.05 (204.5)	13.94 (354)	6.50 (165)	7.09 (180)	13.19 (335)	M6	15 (7)	
		43P71, 45P51, 47P51	8.05 (204.5)	13.94 (354)	7.87 (200)	7.09 (180)	13.19 (335)	M6	22 (10)	
		40111, 40151	11.81 (300)	23.62 (600)	10.31 (262)	11.02 (280)	19.69 (500)	M6	66 (28)	
		40181, 40221	18.50 (470)	27.56 (700)	10.39 (264)	17.52 (445)	23.62 (600)	M8	86 (39)	
		40301, 40371	19.29 (490)	34.45 (875)	11.26 (286)	18.31 (465)	30.51 (775)	M8	137 (62)	
		40451	19.29 (490)	36.02 (915)	11.26 (286)	18.31 (465)	30.51 (775)	M8	137 (62)	
		4L451	25.98 (660)	44.29 (1125)	11.26 (286)	24.80 (630)	39.37 (1000)	M10	227 (103)	
		4L551†	18.11 (460)	44.49 (1130)	12.99 (330)	13.78 (350)	31.30 (795)	M10	203 (92)	
	4L751†	18.11 (460)	44.49 (1130)	12.99 (330)	13.78 (350)	31.30 (795)	M10	203 (92)		
	4LA11†	22.83 (580)	48.62 (1235)	13.98 (355)	17.52 (445)	35.24 (895)	M12	315 (143)		
4LA61†	22.83 (580)	48.62 (1235)	14.96 (380)	17.52 (445)	35.24 (895)	M12	346 (157)			
Water and dust tight type (NEMA4)	42P2, 43P7, 45P5, 47P5	8.29 (210.5)	16.3 (413)	7.89 (200.5)	7.09 (180)	14.0 (355)	M6	26.5 (12)		
500 to 600*	Open chassis type	5090	22.64 (575)	49.21 (1250)	12.99 (330)	18.70 (475)	48.23 (1225)	M10	265 (120)	
		5110, 5160	22.64 (575)	62.99 (1600)	13.98 (355)	18.70 (475)	61.81 (1570)	M12	331 (150)	
	Enclosed wall- mounted type (NEMA1)	51P5, 52P2	8.05 (204.5)	13.94 (354)	6.50 (165)	7.09 (180)	13.19 (335)	M6	15 (7)	
		53P7, 55P5, 57P5	8.05 (204.5)	13.94 (354)	7.87 (200)	7.09 (180)	13.19 (335)	M6	22 (10)	
		5011	12.79 (325)	23.62 (600)	10.83 (275)	9.84 (250)	23.03 (585)	M6	77 (35)	
		5015, 5018, 5022	15.75 (400)	29.53 (750)	11.22 (285)	11.81 (300)	28.74 (730)	M8	99 (45)	
		5030, 5037, 5045	22.64 (575)	33.47 (850)	11.81 (300)	18.70 (475)	32.48 (825)	M10	159 (72)	
		5055	22.64 (575)	41.34 (1050)	12.80 (325)	18.70 (475)	40.35 (1025)	M10	205 (93)	
5075	22.64 (575)	41.97 (1065)	12.80 (325)	18.70 (475)	40.35 (1025)	M10	205 (93)			

COMPACT DESIGN FOR SMALL SPACES

Enclosed Wall-mounted Type

Dimensions in inch (mm)

200 to 230V

0.5 to 2HP (0.4 to 1.5kW) (Model CIMR-G3□20P4 to -G3□21P5)

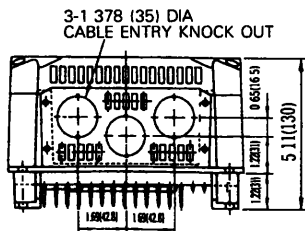
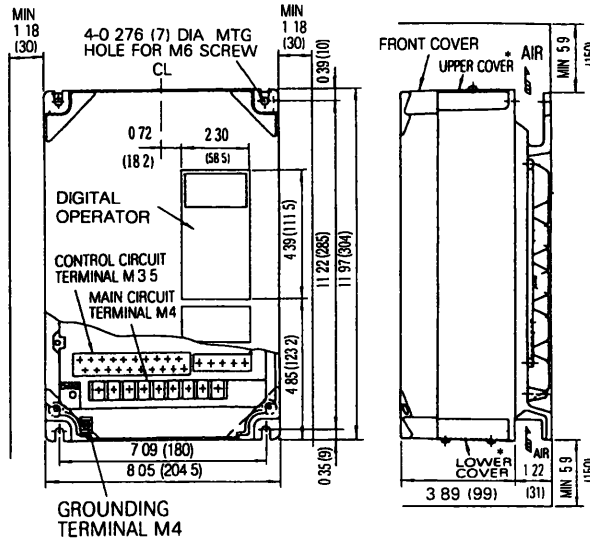

Approx.
Mass: 9 lb (4 kg)

*: To use the unit as an open chassis type, remove the upper and lower covers.

3/5HP (2.2/3.7kW) (Model CIMR-G3□22P2-G3□23P7)

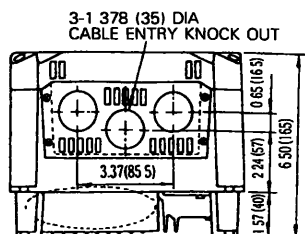
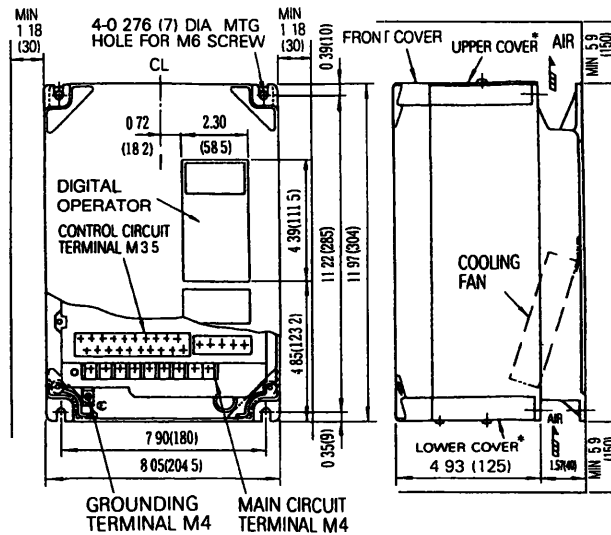

Approx.
Mass: 15 lb (7 kg)

*: To use the unit as an open chassis type, remove the upper and lower covers.

Enclosed Wall-mounted Type

Dimensions in inch (mm)

200 to 230V

7.5/10HP (5.5/7.5kW) (Model CIMR-G3□25P5/G3□27P5)

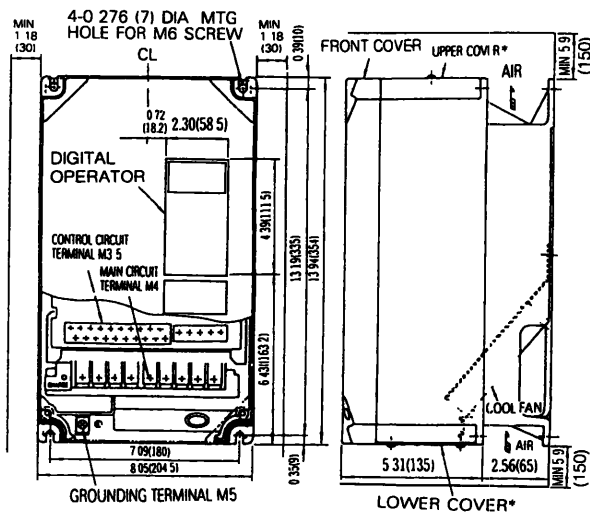

3-1 732 (44) DIA CABLE ENTRY KNOCK OUT

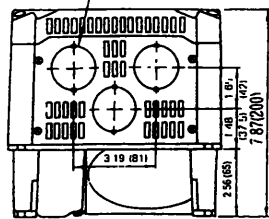

Approx.
Mass: 22 lb (10 kg)

*: To use the unit as an open chassis type, remove the upper and lower covers.

15HP (11kW) (Model CIMR-G3□2011)

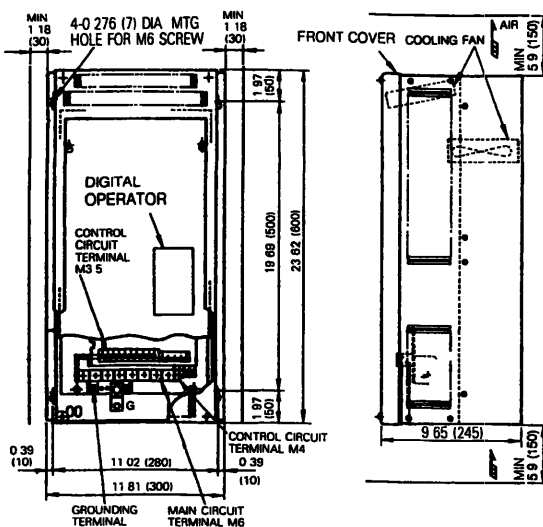

3 1 969 (50) DIA CABLE ENTRY KNOCK OUT

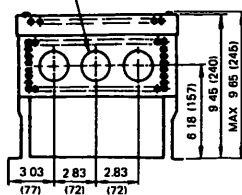

Approx.
Mass: 57 lb (26 kg)

200 to 230V

20HP (15kW) (Model CIMR-G3□2015)

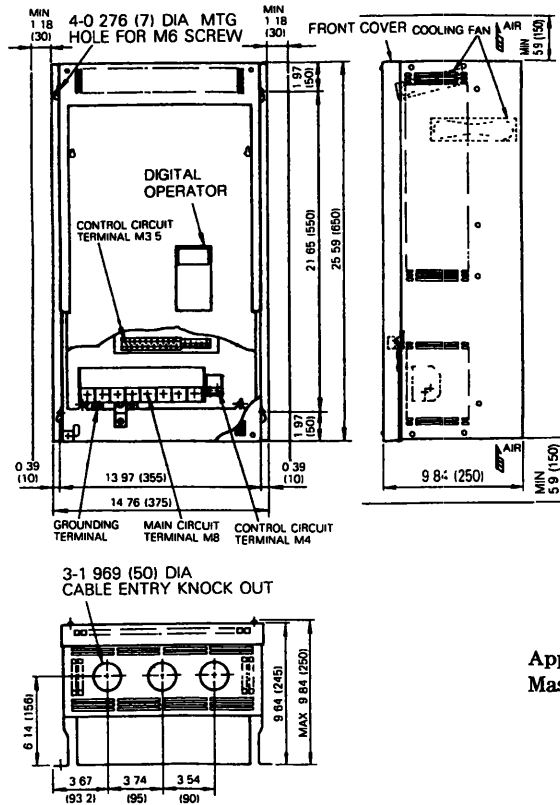

Approx
Mass: 70 lb (32 kg)

25HP (18.5kW) (Model CIMR-G3□2018)

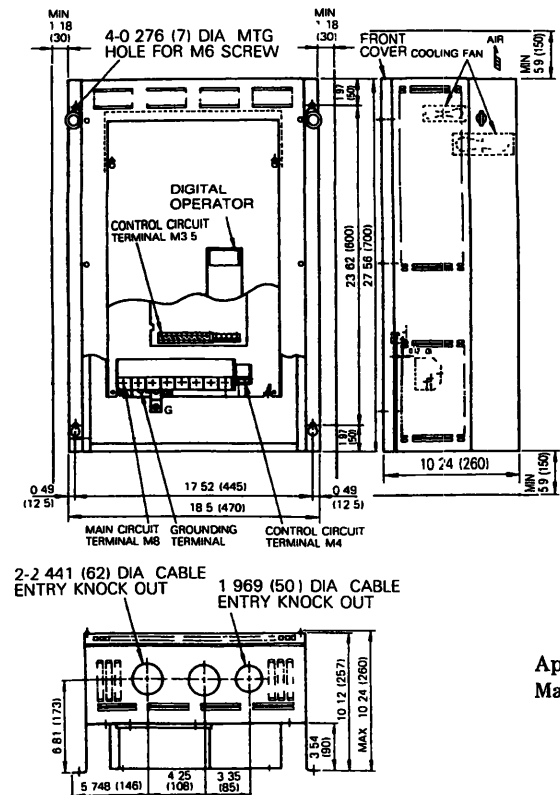

Approx.
Mass 95 lb (43 kg)

Enclosed Wall-mounted Type

Dimensions in inch (mm)

200 to 230V

30HP (22kW) (Model CIMR-G3□2022)

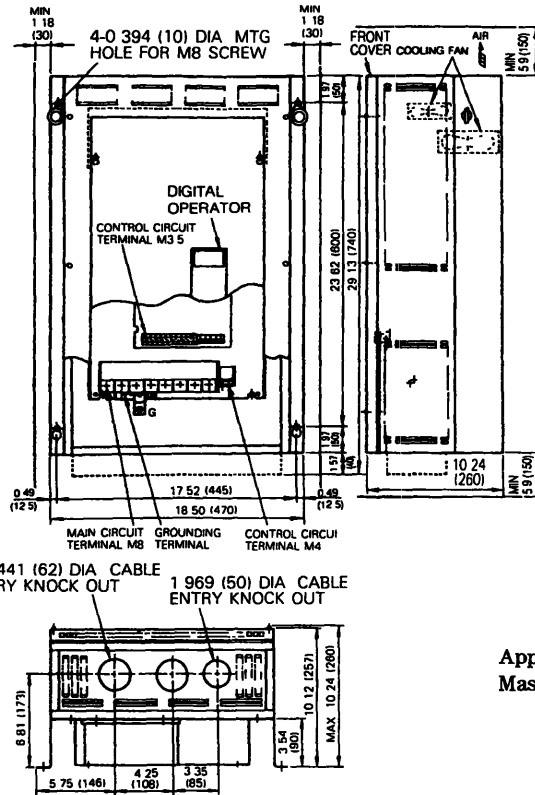

Approx.
Mass 95 lb (43 kg)

380 to 460V

0.5 to 3HP (0.4 to 2.2kW) (Model CIMR-G3□40P4 to -G3□42P2)

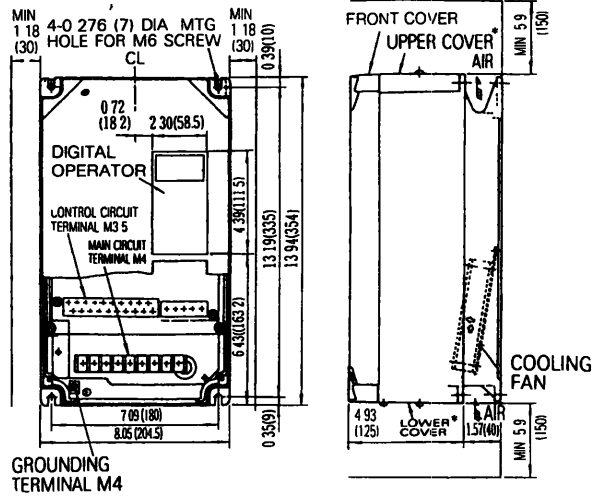

GROUNDING TERMINAL M4

3-1 378 (35) DIA CABLE ENTRY KNOCK OUT

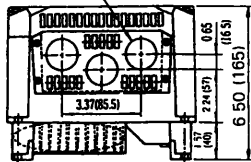

Approx
Mass: 15 lb (7 kg)

* To use the unit as an open chassis type, remove the upper and lower covers

5 to 10HP (3.7 to 7.5kW) (Model CIMR-G3□43P7 to -G3□47P5)

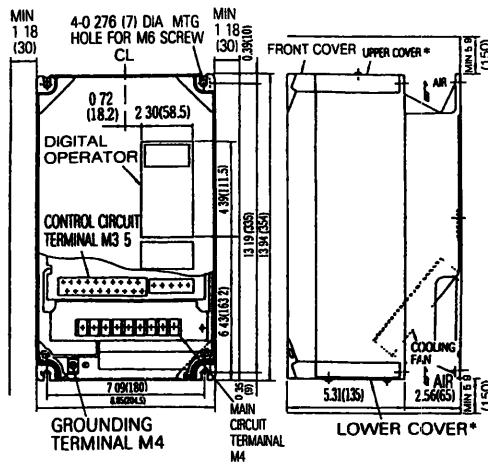

GROUNDING TERMINAL M4

MAIN CIRCUIT TERMINAL M4

3-1 732 (44) DIA CABLE ENTRY KNOCK OUT

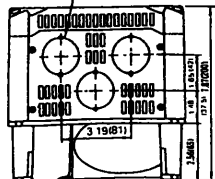

Approx.
Mass. 22 lb (10 kg)

*: To use the unit as an open chassis type, remove the upper and lower covers.

Enclosed Wall-mounted Type

Dimensions in inch (mm)

380 to 460V

15HP (11kW) (Model CIMR-G3□4011)

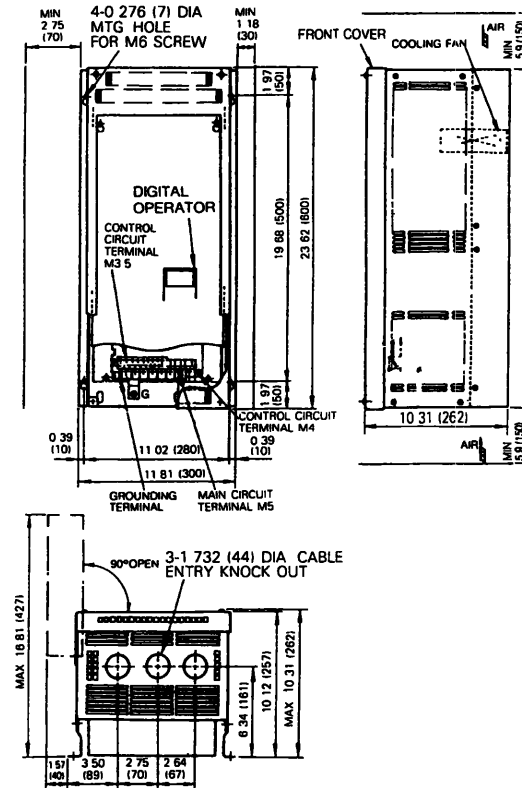

Approx.
Mass: 59 lb (27 kg)

20HP (15kW) (Model CIMR-G3□4015)

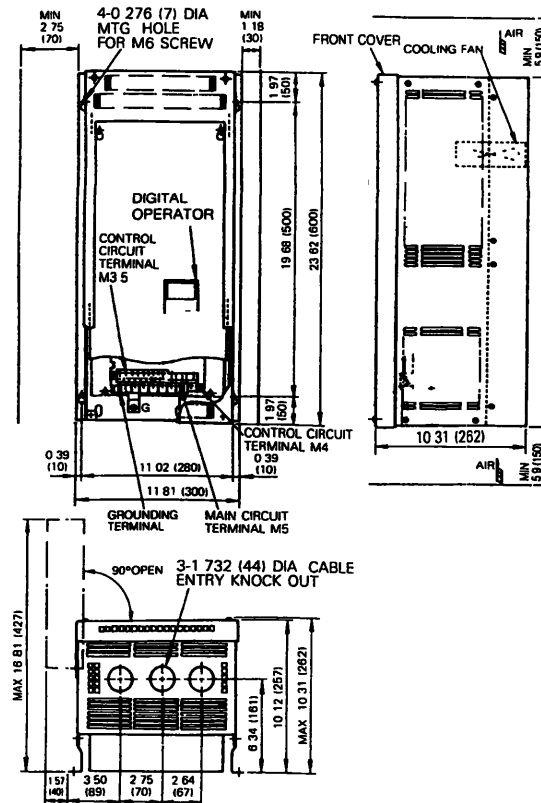

Approx
Mass: 62 lb (28 kg)

380 to 460V

25/30HP (18.5/22kW) (Model CIMR-G3□4018/-G3□4022)

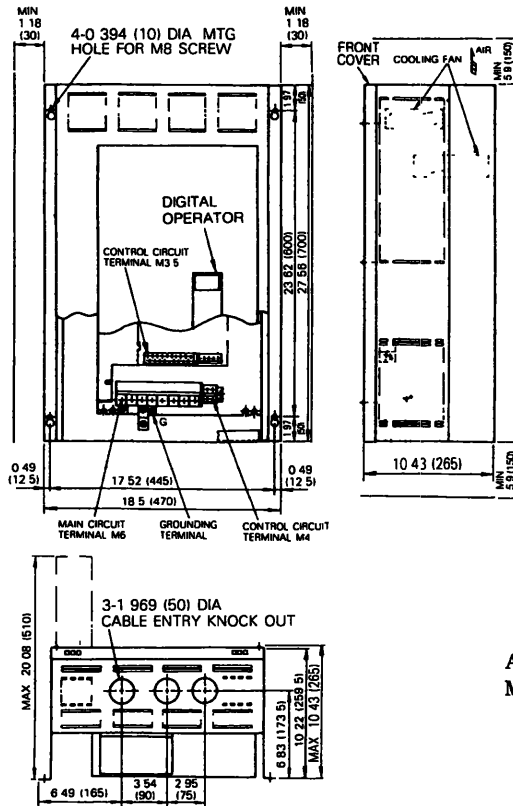

Approx
Mass 86 lb (39 kg)

40/50HP (30/37kW) (Model CIMR-G3□4030/-G3□4037)

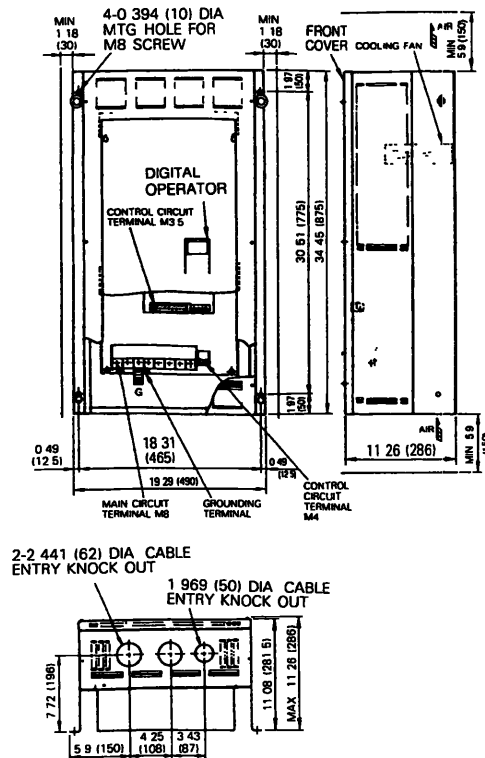

MODEL	APPROX MASS
CIMR-G3□4030	130 lb (59 kg)
CIMR-G3□4037	137 lb (62 kg)

Enclosed Wall-mounted Type

Dimensions in inch (mm)

380 to 460V

60HP (45kW) (Model CIMR-G3 4045)

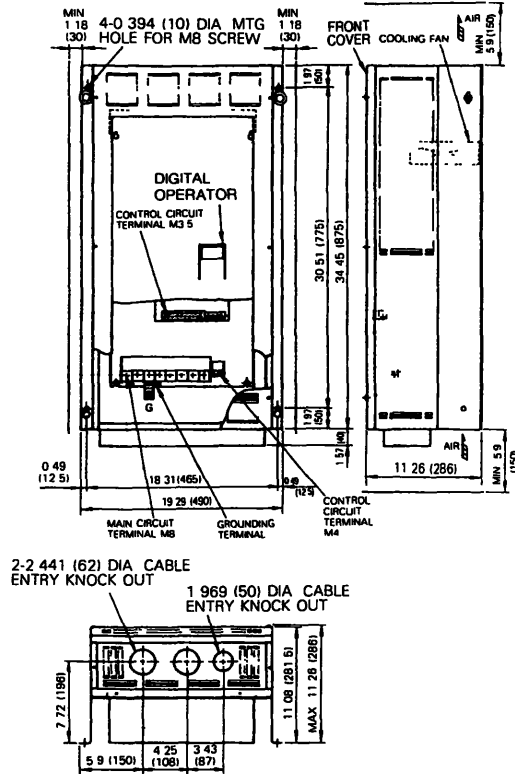

Approx.
Mass: 137 lb (62 kg)

60HP (45kW) (Model CIMR-G3A4L45)

Low-noise Type

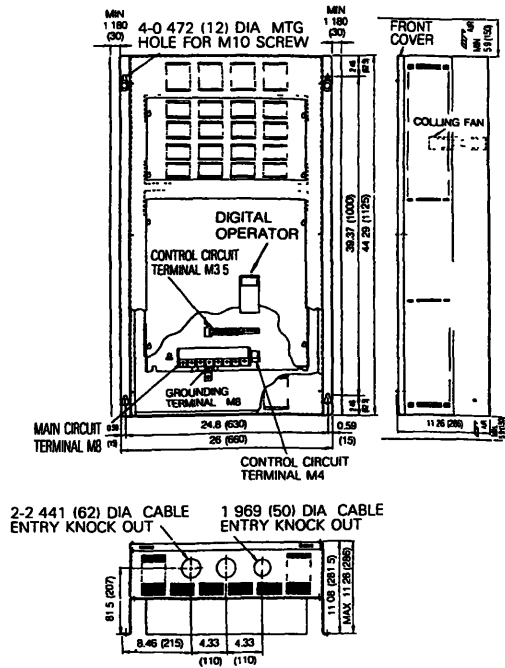

Approx.
Mass: 137 lb (103 kg)

380 to 460V

75/100HP (55/75kW) (Model CIMR-G3□4L55/-G3□4L75)

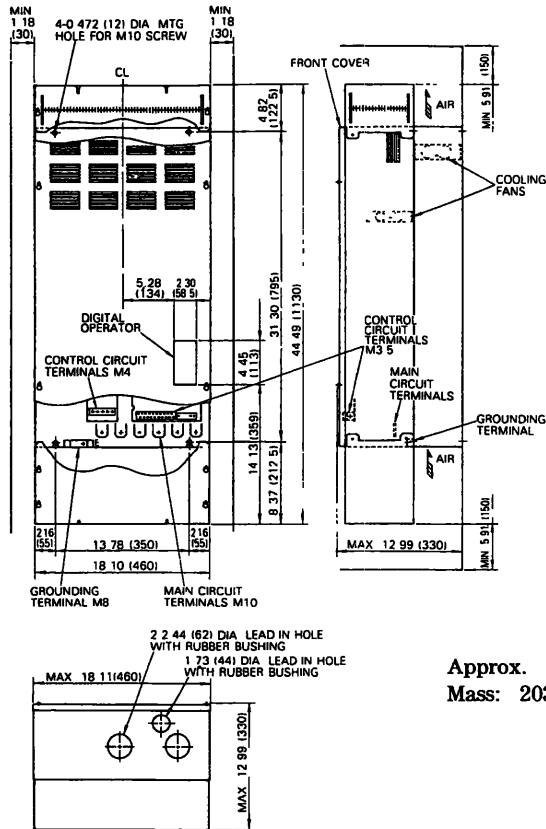

Approx.
Mass: 203 lb (92 kg)

150HP (110kW) (Model CIMR-G3□4LA1)

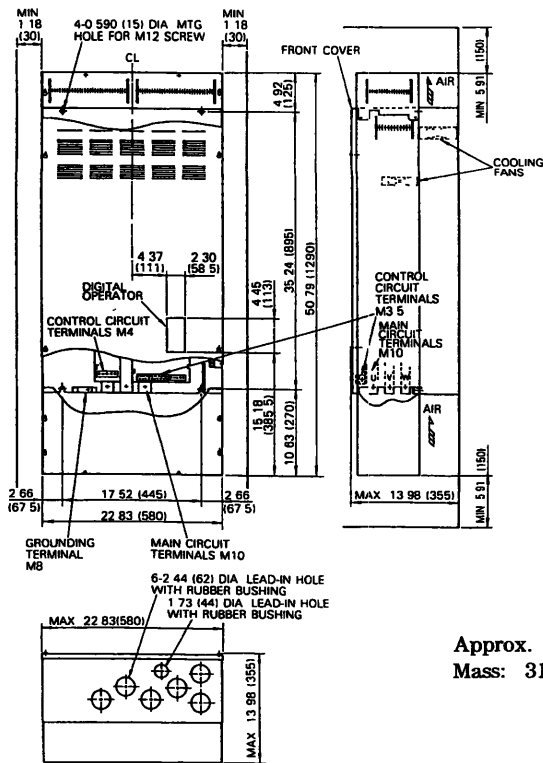

Approx.
Mass: 315 lb (143 kg)

Enclosed Wall-mounted Type

Dimensions in inch (mm)

380 to 460V

200HP (160kW) (Model CIMR-G3□4LA6)

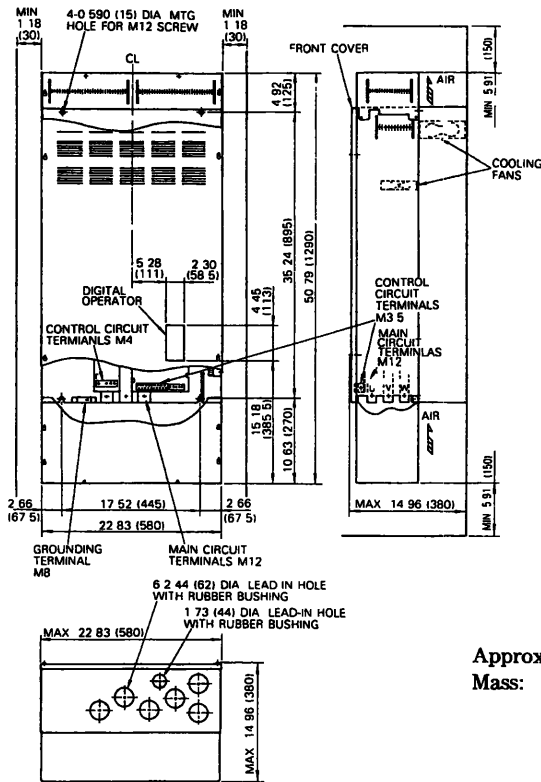

Approx.
Mass: 346 lb (157 kg)

500 to 600V

2/3HP (1.5/2.2kW) (Model CIMR-G3□51P5/-G3□52P2)

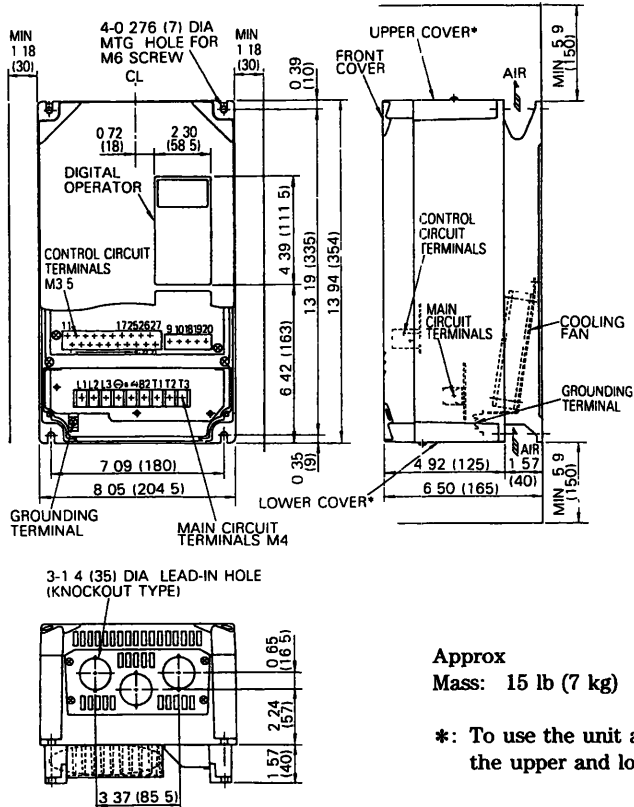

5 to 10HP (3.7 to 7.5kW) (Model CIMR-G3□53P7 to -G3□57P5)

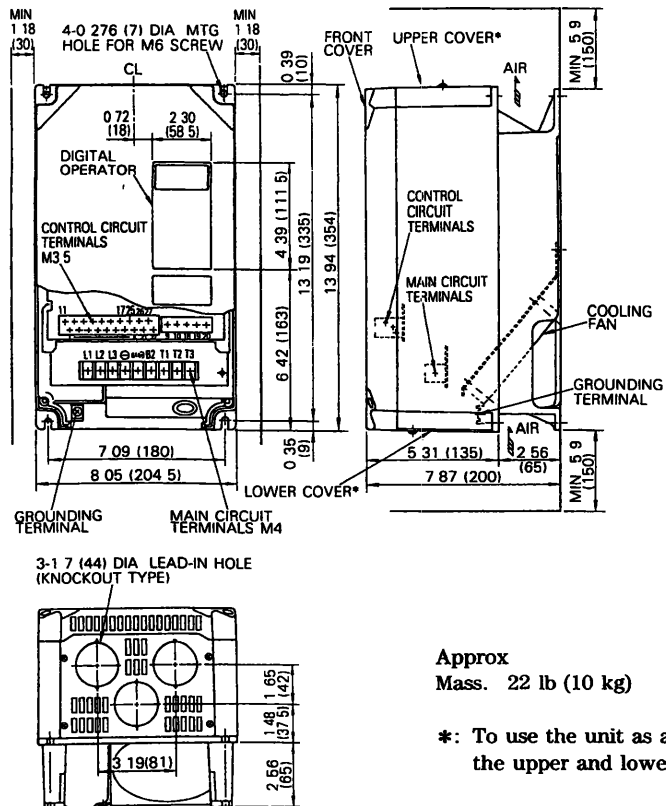

Enclosed Wall-mounted Type

Dimensions in inch (mm)

500 to 600V

15HP (11kW) (Model CIMR-G3□5011)

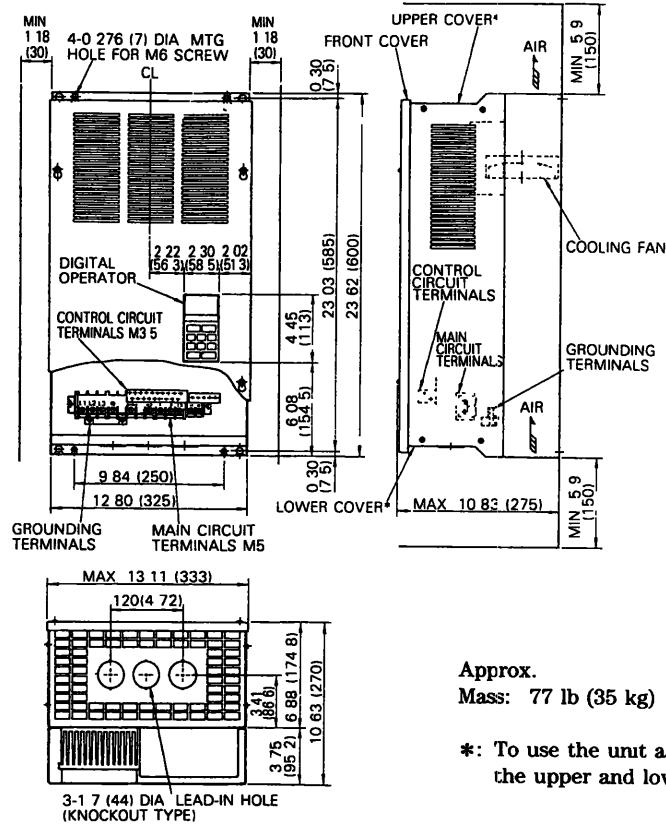

Approx.
Mass: 77 lb (35 kg)

*: To use the unit as an open chassis type, remove the upper and lower covers.

20 to 30HP (15 to 22kW) (Model CIMR-G3□5015 to -G3□5022)

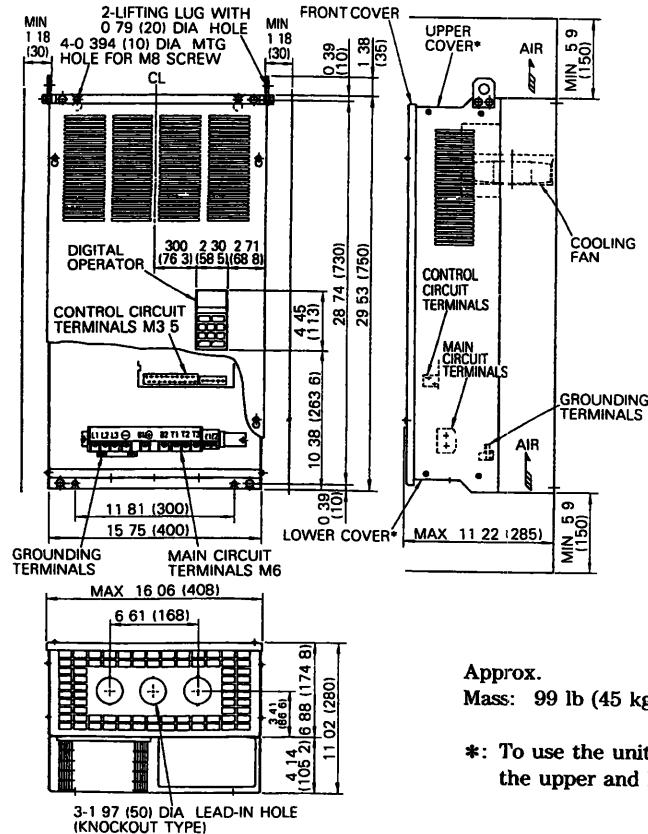

Approx.
Mass: 99 lb (45 kg)

*: To use the unit as an open chassis type, remove the upper and lower covers.

500 to 600V

40/50HP (30/37kW) (Model CIMR-G3□5030/-G3□5037)

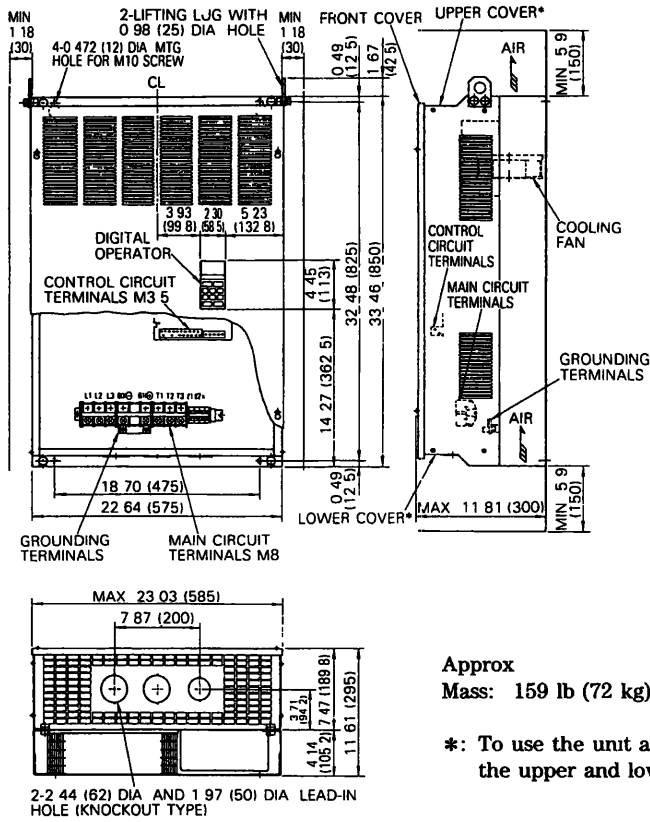

Approx
Mass: 159 lb (72 kg)

*: To use the unit as an open chassis type, remove the upper and lower covers.

60HP (45kW) (Model CIMR-G3□5045)

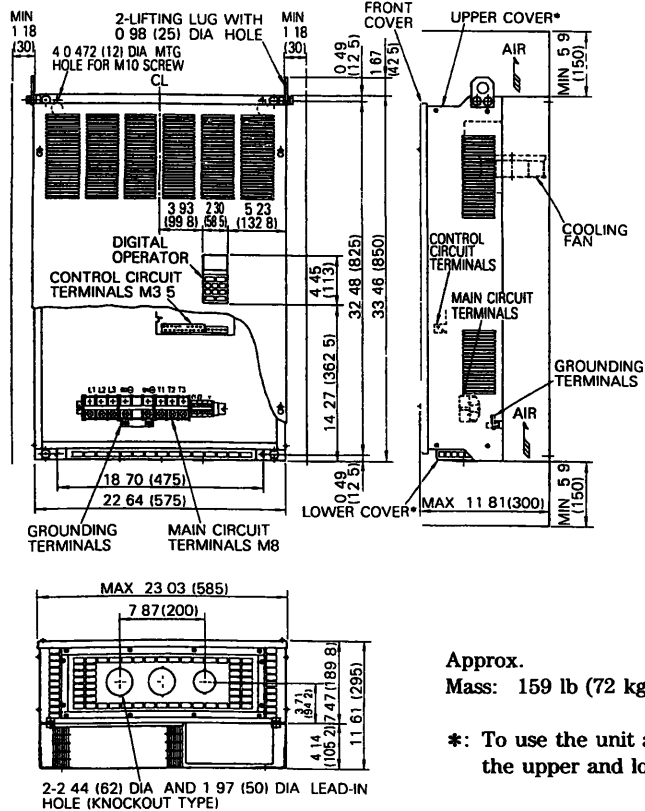

Approx.
Mass: 159 lb (72 kg)

*: To use the unit as an open chassis type, remove the upper and lower covers.

Enclosed Wall-mounted Type

Dimensions in inch (mm)

500 to 600V

75HP (55kW) (Model CIMR-G3□5055)

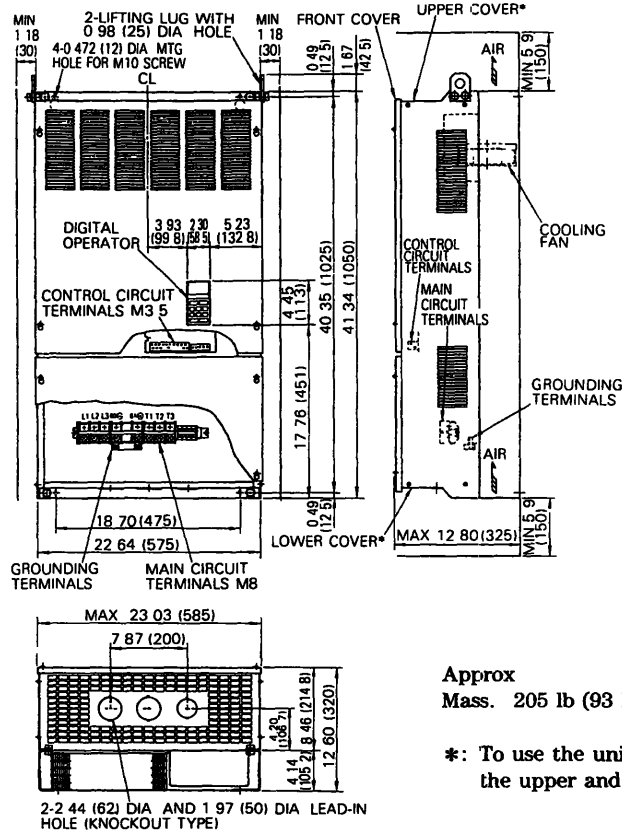

Approx
Mass. 205 lb (93 kg)

*: To use the unit as an open chassis type, remove the upper and lower covers

100HP (75kW) (Model CIMR-G3□5075)

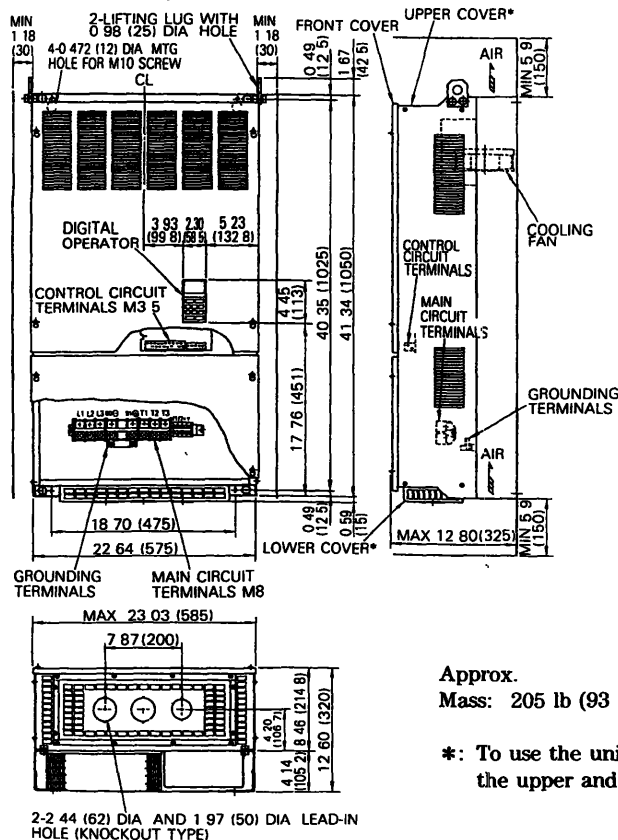

Approx.
Mass: 205 lb (93 kg)

*: To use the unit as an open chassis type, remove the upper and lower covers.

Open Chassis Type

Dimensions in inch (mm)

200 to 230V

15HP (11kW) (Model CIMR-G3□2011)
Non-UL Listed Type

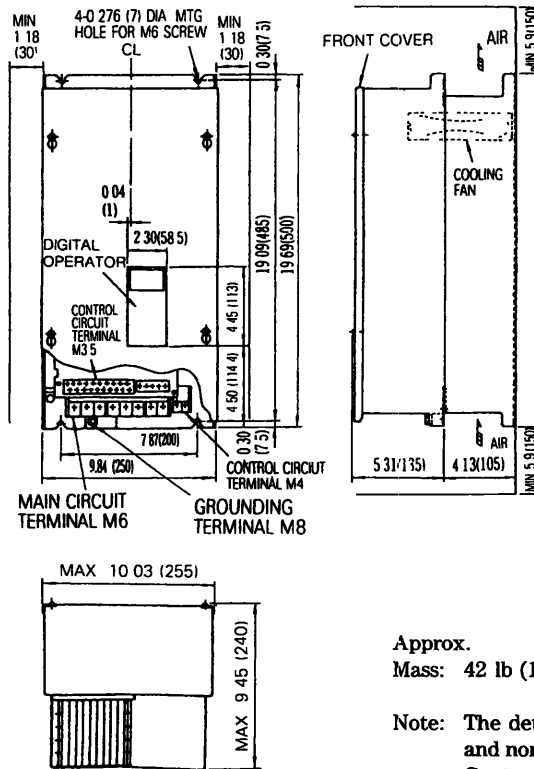

Approx.
Mass: 42 lb (19 kg)

Note: The detailed dimensions of UL/CSA listed type and non UL/CSA listed type is different slightly. Contact your YASKAWA representative.

20HP (15kW) (Model CIMR-G3□2015)

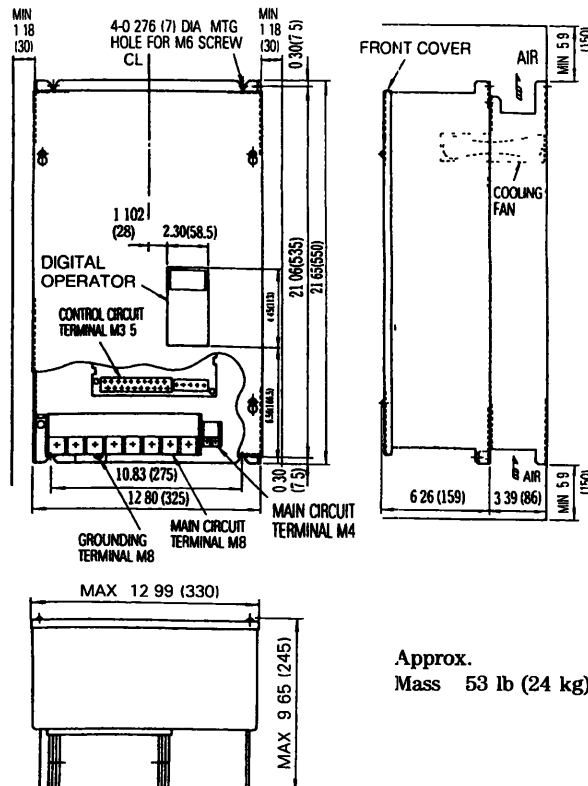

Approx.
Mass 53 lb (24 kg)

Note. The open chassis type dimensions of 0.5 to 10HP (0.4 to 7.5kW) (Model CIMR-G3□20P4 to -G3□27P5) are same as enclosed wall-mounted type dimensions. See pages 19 and 20.

Open Chassis Type

Dimensions in inch (mm)

200 to 230V

25/30HP (18.5/22kW) (Model CIMR-G3□2018/-G3□2022)

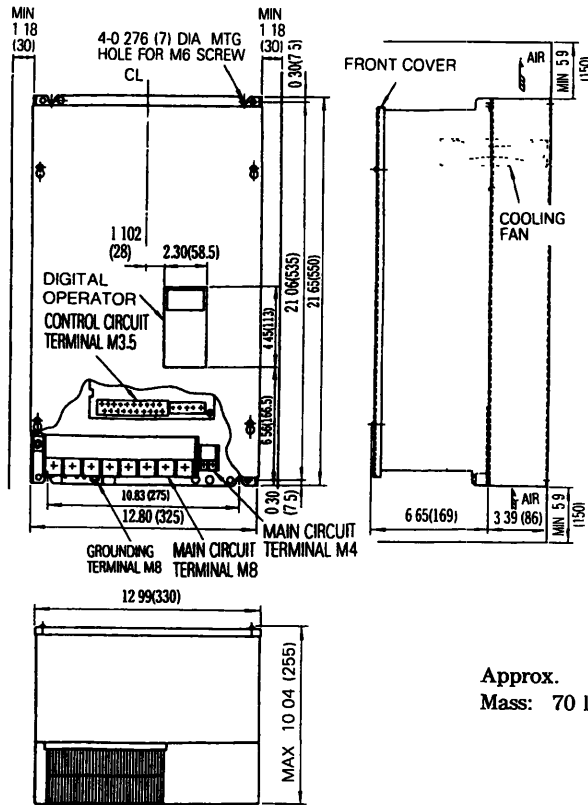

Approx.
Mass: 70 lb (32 kg)

40HP (30kW) (Model CIMR-G3□2030)

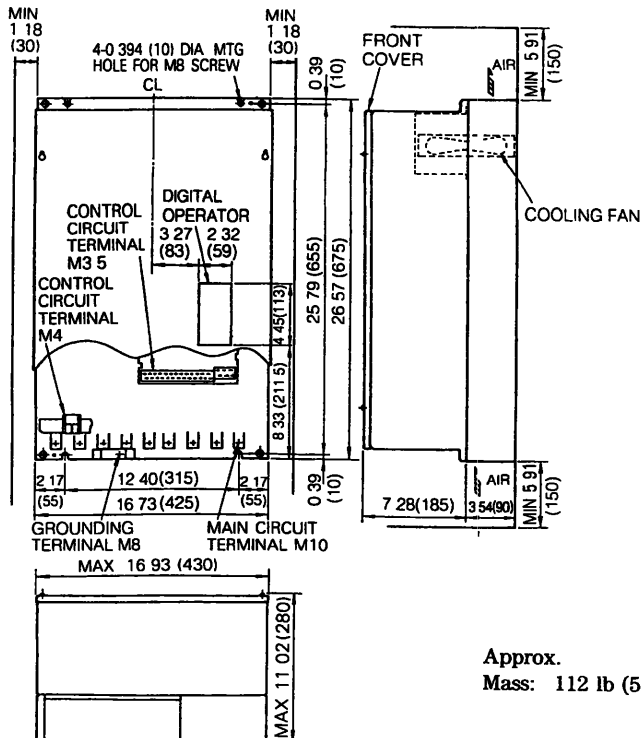

Approx.
Mass: 112 lb (51 kg)

200 to 230V

50HP (37kW) (Model CIMR-G3□2037)

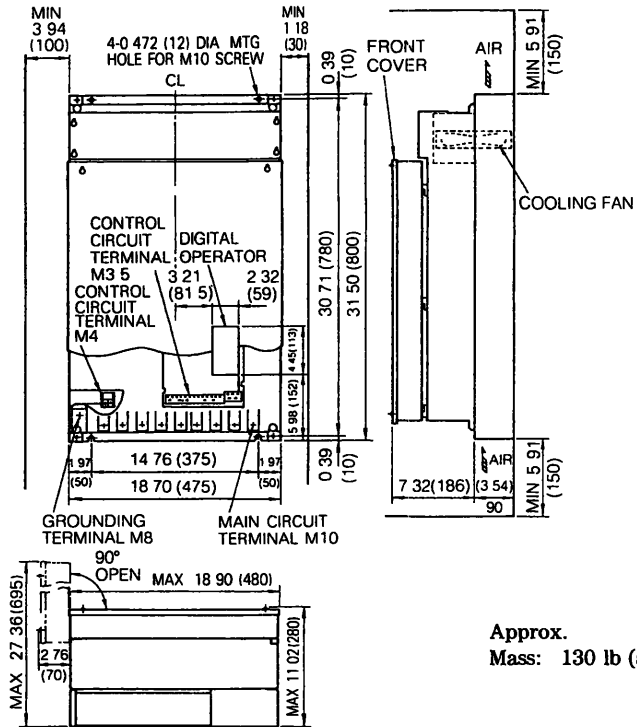

Approx.
Mass: 130 lb (59 kg)

60/75HP (45/55kW) (Model CIMR-G3□2045/-G3□2055)

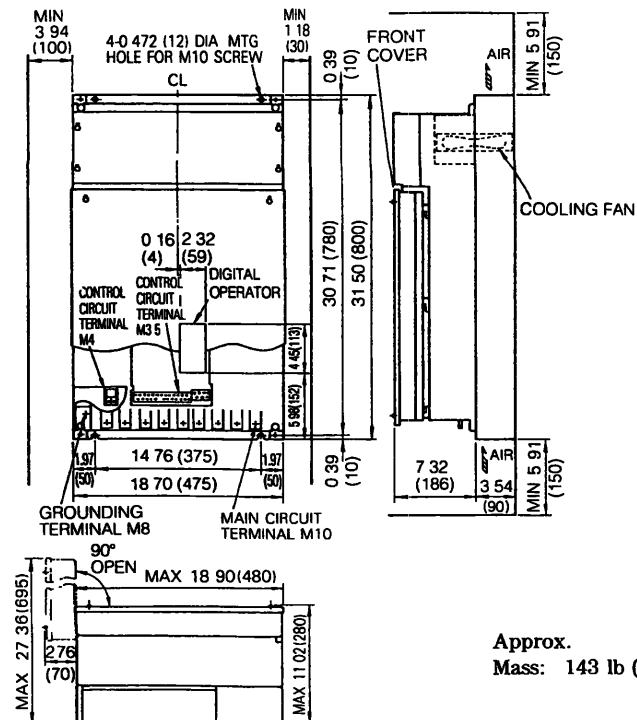

Approx.
Mass: 143 lb (65 kg)

Open Chassis Type

Dimensions in inch (mm)

200 to 230V

100HP (75kW) (Model CIMR-G3□2075)

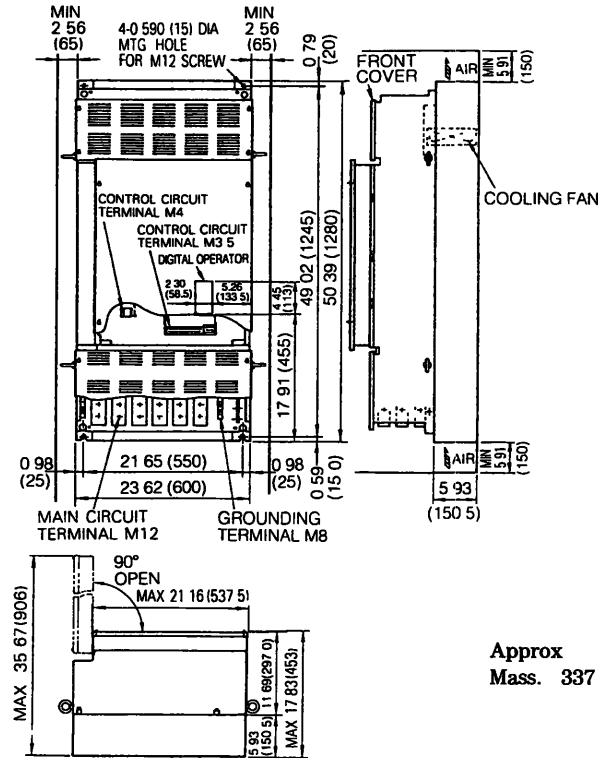

Approx
Mass: 337 lb (153 kg)

3 to 10HP (2.2 to 7.5kW) (Model CIMR-G3A22P2 to -G3A27P5)

Water and Dust Tight Type

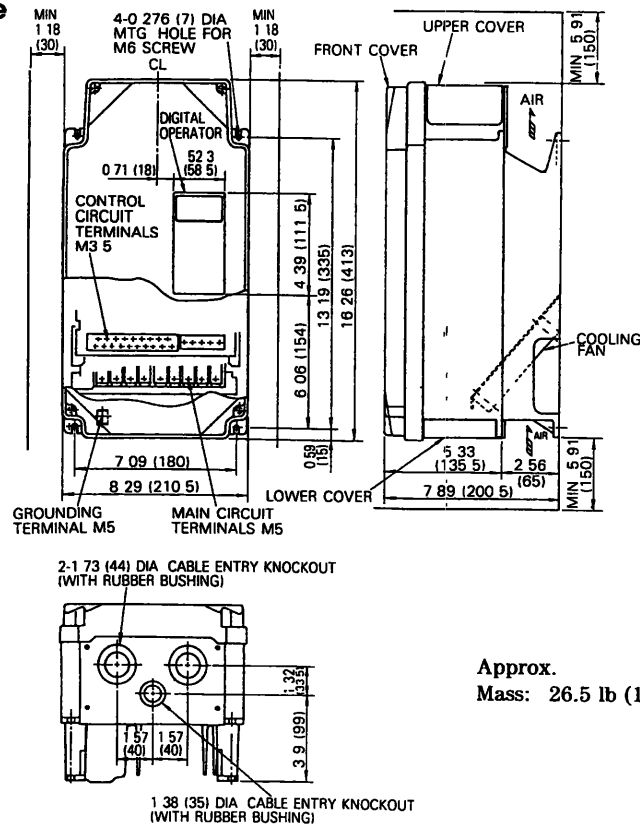

Approx.
Mass: 26.5 lb (12 kg)

380 to 460V

15/20HP (11/15kW) (Model CIMR-G3□4011/-G3□4015)

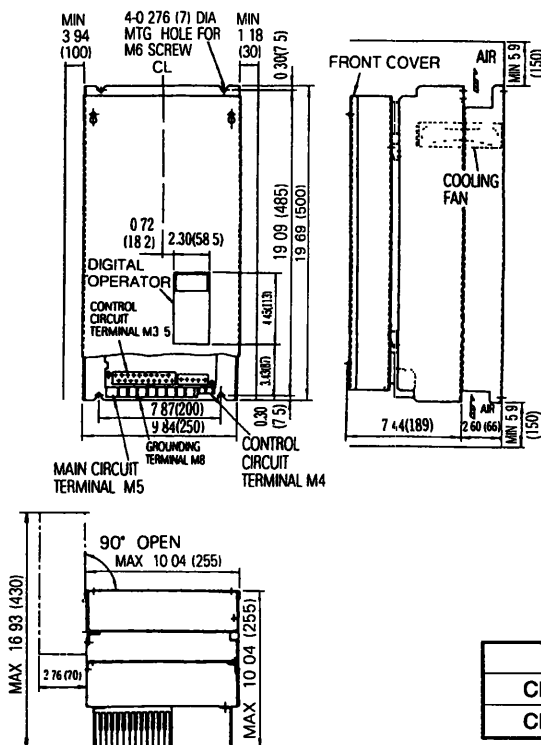

25/30HP (18.5/22kW) (Model CIMR-G3□4018/-G3□4022)

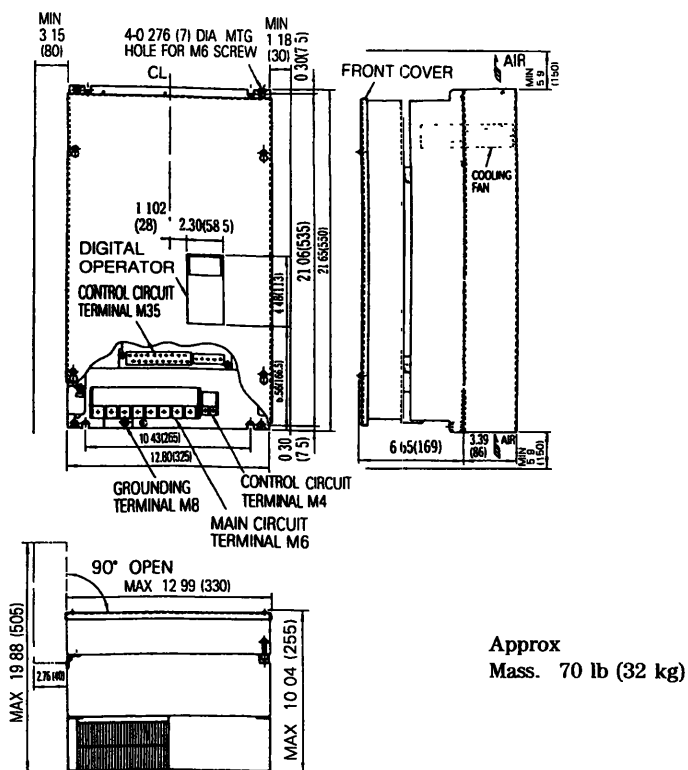

Note: The open chassis type dimensions of 0.5 to 10HP (0.4 to 7.5kW) (Model CIMR-G3□40P4 to -G3□47P5) are same as enclosed wall-mounted type dimensions. See page 23.

Open Chassis Type

Dimensions in inch (mm)

380 to 460V

40 to 60HP (30 to 45kW) (Model CIMR-G3□4030 to -G3□4045)

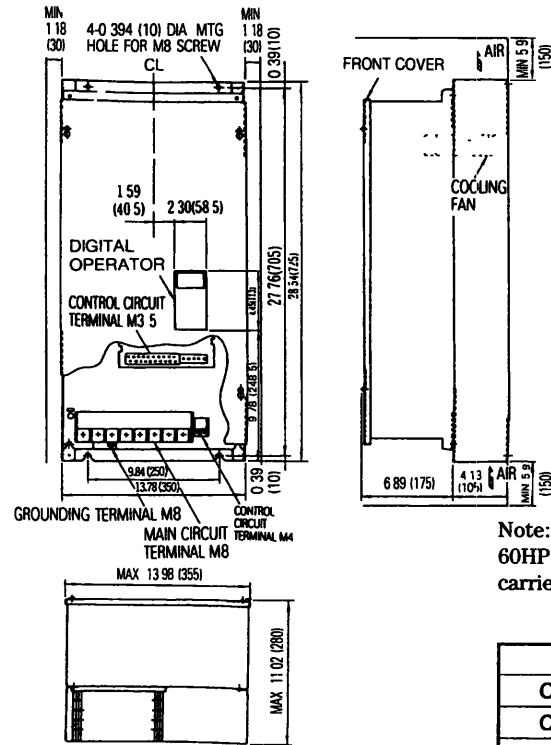

Note:
60HP (45kW) model is compact, low-carrier frequency type

MODEL	APPROX MASS
CIMR-G3□4030	93 lb (42 kg)
CIMR-G3□4037	99 lb (45 kg)
CIMR-G3□4045	99 lb (45 kg)

60HP (45kW) (Model CIMR-G3□4L45) Low-noise Type

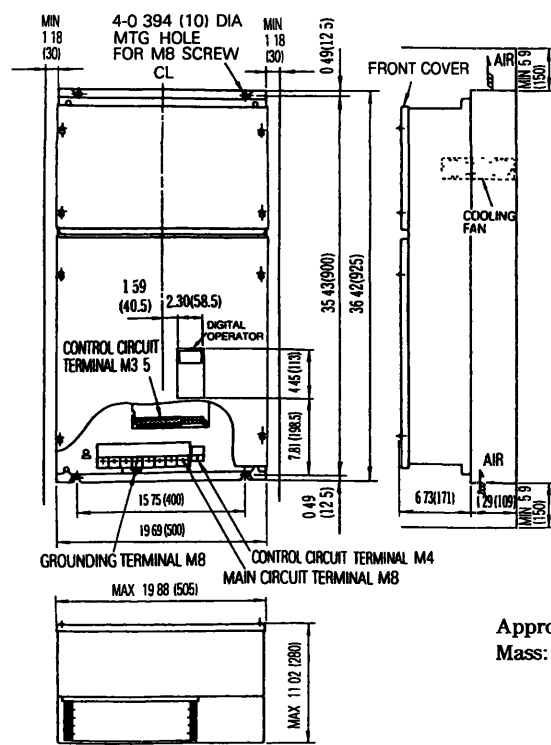

Approx.
Mass: 161 lb (73 kg)

380 to 460V

75/100HP (55/75kW) (Model CIMR-G3□4L55/-G3□4L75)

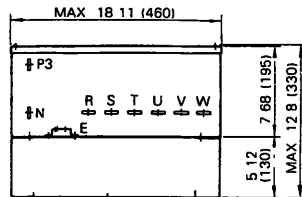
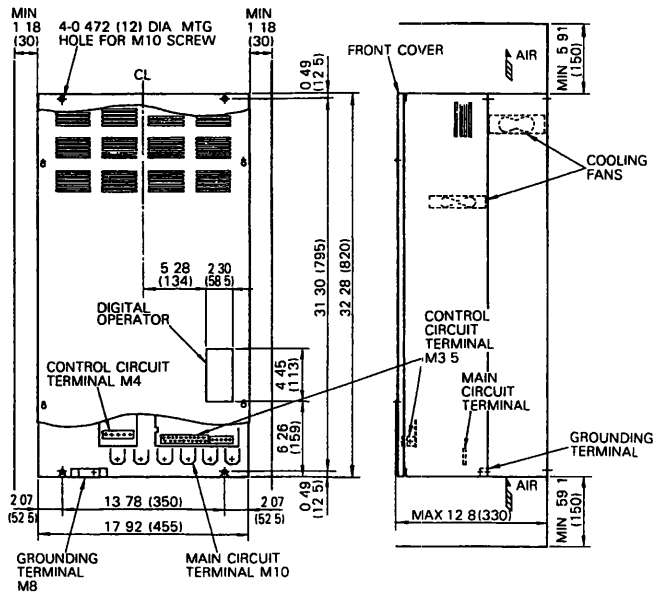

Approx.
Mass: 190 lb (86 kg)

150HP (110kW) (Model CIMR-G3□4LA1)

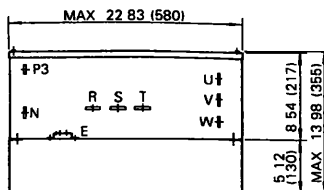
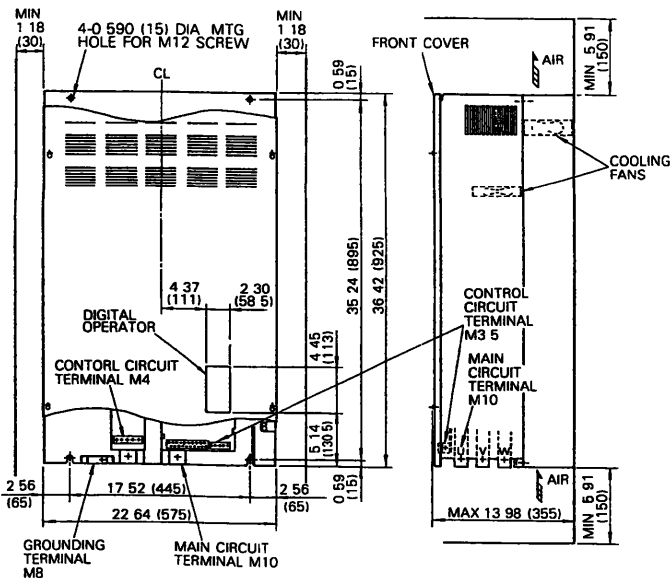

Approx.
Mass: 291 lb (132 kg)

Open Chassis Type

Dimensions in inch (mm)

380 to 460V

200HP (160kW) (Model CIMR-G3□4LA6)

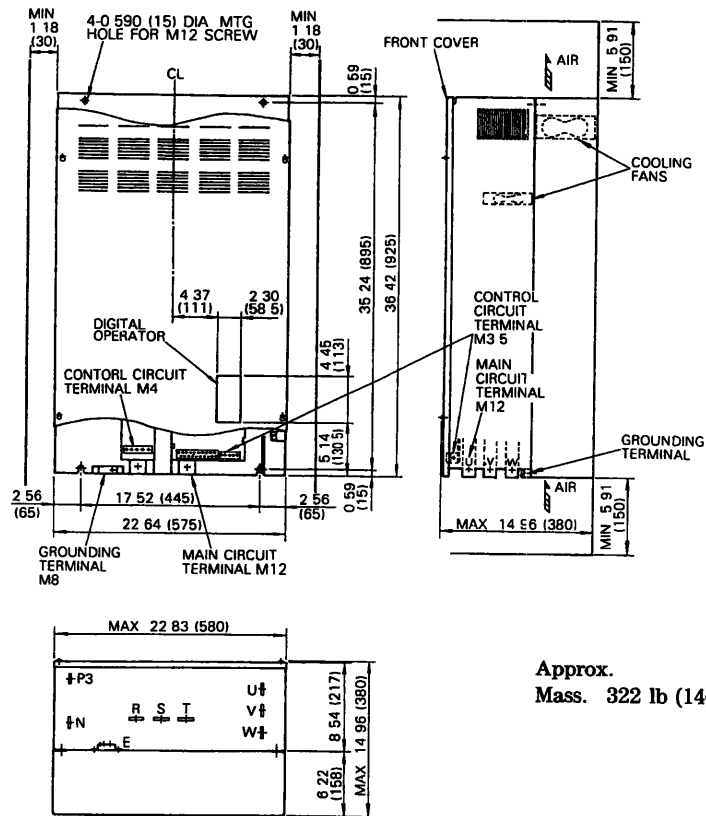

Approx.
Mass. 322 lb (146 kg)

250/300HP (185/220kW) (Model CIMR-G3□4185/-G3□4220)

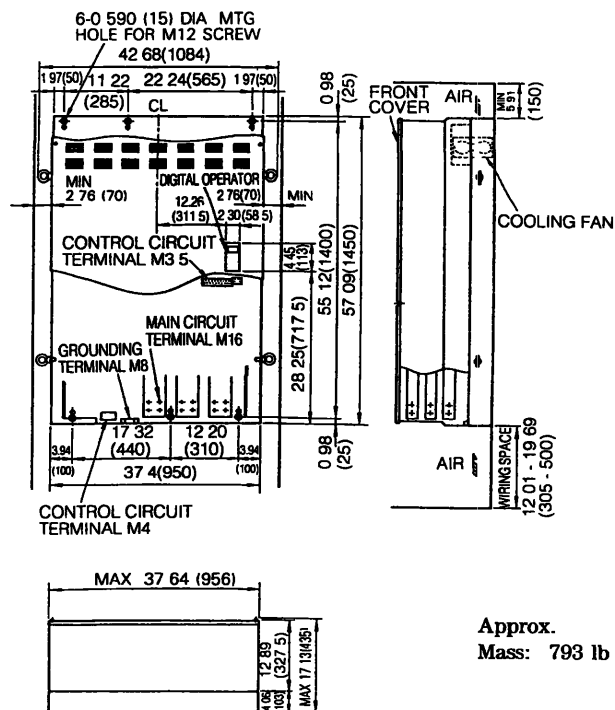

Approx.
Mass: 793 lb (360 kg)

380 to 460V

400HP (300kW) (Model CIMR-G3□4300)

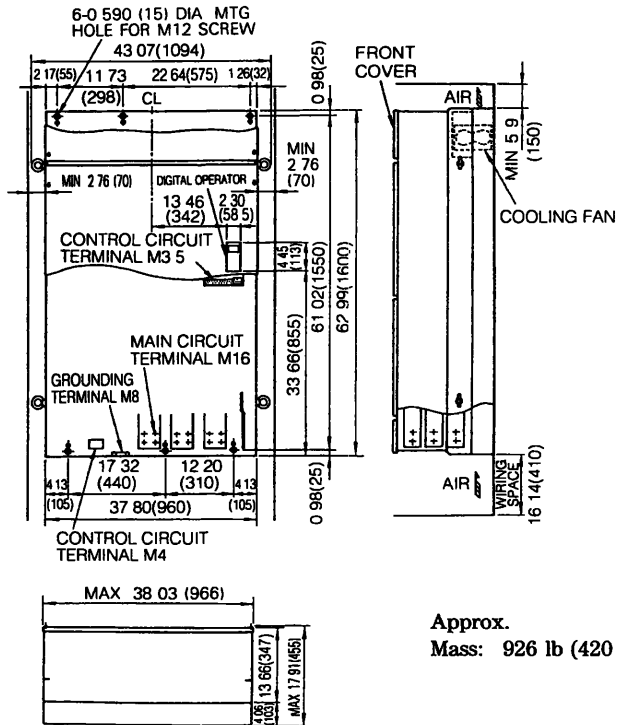

3 to 10HP (2.2 to 7.5kW) (Model CIMR-G3A42P2 to -G3A47P5) Water and Dust Tight Type

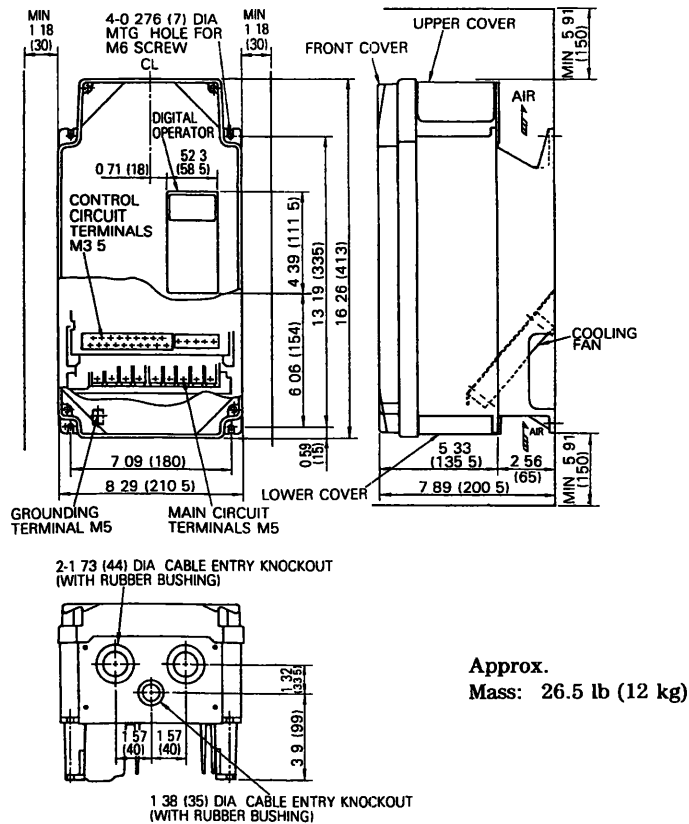

Easy Modification to Gasketed Cabinet

Open chassis cabinet incorporating heat sink can be easily changed to gasketed enclosure by relocating the heat sink outside the casting and gasketing the mounting face.

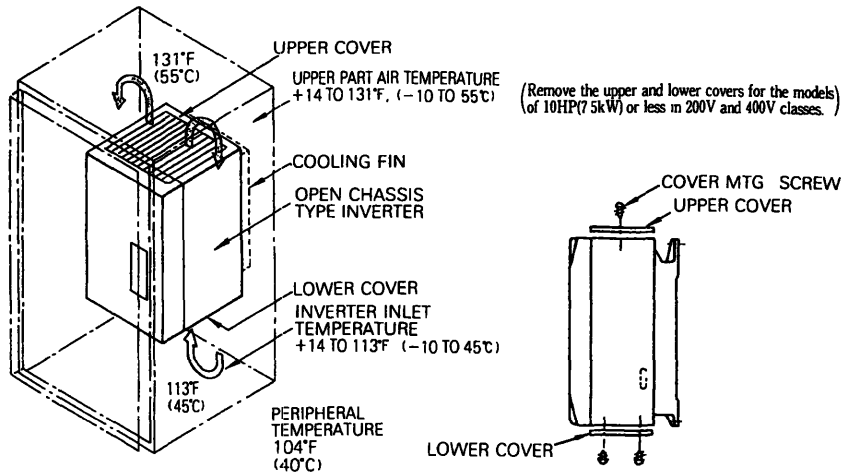

Inverter Unit Cooling Fin Dimensions

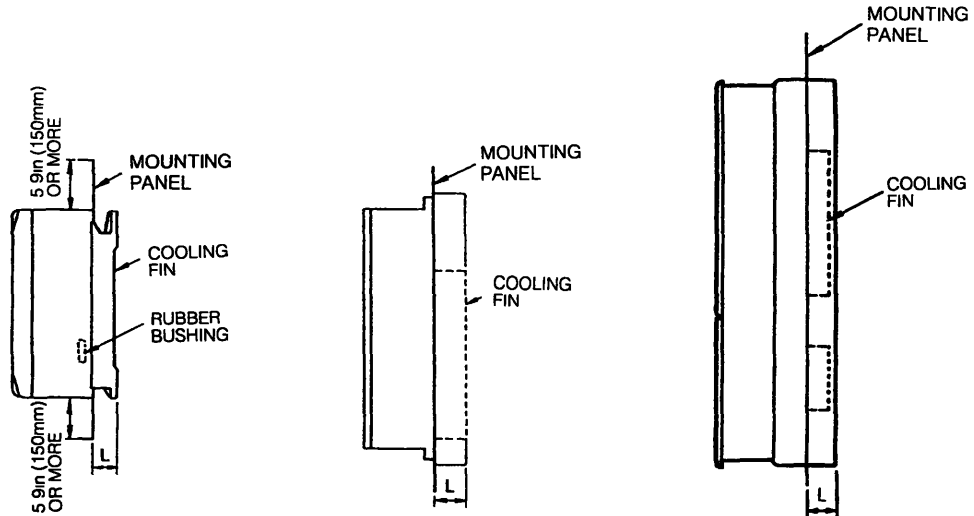

200/400V Class

0.5 to 10HP
(0.4 to 7.5kW)

15 to 200HP
(11 to 160kW)

250 to 400HP
(185 to 300kW)

575V Class

2 and 3HP
(1.5 and 2.2kW)

5 to 25HP
(3.7 to 18.5kW)

Voltage Class	200 to 230V								380 to 460V							500 to 600V					
	20P4 20P7	21P5	22P2 23P7	25P5 27P5	2011	2015 to 2022	2030 to 2055	2075	40P4 to 42P2	43P7 to 47P5	4011 to 4015	4018 to 4022	4030 to 4045	41A5 to 4110	4160	4185 to 4300	51P5 52P2	53P7 to 57P5	5011	5015 to 5075	5090 to 5160
Cooling Fin Dimensions L max. inch (mm)	1.22 (31)	1.22 (31)	1.57 (40)	2.56 (65)	4.13 (105)	3.39 (86)	3.54 (90)	5.93 (150.7)	1.57 (40)	2.56 (65)	2.60 (66)	3.39 (86)	4.17 (106)	4.29 (109)	5.93 (150.7)	4.06 (103)	1.57 (40)	2.56 (65)	3.75 (95.2)	4.14 (105.2)	4.13 (105)
Number of Rubber Bushings	—	4	6	2	—	—	—	—	—	2	—	—	—	—	—	—	3	3	3	3	—

Note: For installation on a totally-enclosed type control panel, rubber bushing (Code No. FL6402826-1) may be required depending on the model. Procure necessary rubber bushings separately.

Rubber Bushing Dimensions in inch (mm)

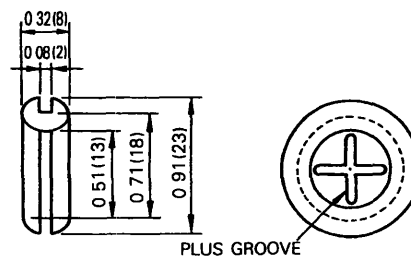

INVERTER HEAT LOSS

200 to 230V

Model CIMR - G 3 □		20P4	20P7	21P5	22P2	23P7	25P5	27P5	2011	2015	2018	2022	2030	2037	2045	2055	2075	
Inverter Capacity kVA		1.4	2.1	2.7	4.1	6.9	10.3	13.7	20.6	27.4	34	41	54	68	78	95	130	
Rated Current A		3.2	4.8	6.4	9.6	16	24	32	48	64	80	96	130	160	183	224	300	
Heat Loss W	Fin	25	30	45	100	170	235	310	465	575	785	940	1170	1580	1360	1800	1990	
	Inside Unit	60	75	95	100	135	165	210	295	415	575	680	500	510	780	830	980	
	Total Heat Loss	85	105	140	200	305	400	520	760	990	1360	1620	1670	2090	2140	2630	2970	
Fin Cooling		Self cooled					Fan cooled											

380 to 460V

Model CIMR - G 3 □		40P4	40P7	41P5	42P2	43P7	45P5	47P5	4011	4015	4018	4022	4030	4037	4L45	4L55	4L75	4LA1	4LA6	4045	4185	4220	4300
Inverter Capacity kVA		1.4	2.2	3.4	4.1	6.9	10.3	13.7	20.6	27.4	34	41	54	68	82	110	140	200	250	82	290	380	510
Rated Current A		1.6	2.6	4.0	4.8	8	12	16	24	32	40	48	64	80	96	128	165	224	300	96	340	450	600
Heat Loss W	Fin	25	45	65	80	145	205	275	300	385	465	555	1175	1350	1570	1110	1430	1870	2670	975	3400	4740	6820
	Inside Unit	55	60	70	80	110	155	185	205	255	305	365	595	760	800	710	890	1160	1520	770	1510	2110	2910
	Total Heat Loss	80	105	135	160	255	360	460	505	640	770	920	1770	2110	2370	1820	2320	3030	4190	1745	4910	6850	9730
Fin Cooling		Fan cooled																					

500 to 600V

Model CIMR - G 3 □		51P5	52P2	53P7	55P5	57P5	5011	5015	5018	5022	5030	5037	5045	5055	5075	5090	5110	5160
Inverter Capacity kVA		2	3	5	7.5	10	15	20	25	30	40	50	60	75	100	125	150	200
Rated Current A		3.5	4.1	6.3	9.8	12.5	17	22	27	32	41	52	62	77	99	130	172	200
Heat Loss W	Fin	40	50	100	150	210	280	360	440	610	810	1010	1070	1320	1380	1560	1900	2300
	Inside Unit	70	90	100	150	190	220	270	320	410	550	690	710	970	1050	1370	1600	2150
	Total Heat Loss	110	140	200	300	400	500	630	760	1020	1360	1700	1780	2290	2430	2930	3500	4450
Fin Cooling		Fan cooled																

Panel Cut for External Installation of Cooling Fin

200 to 230V

Dimensions in inch (mm)

<p>0.5 to 2HP (0.4 to 1.5kW) (CIMR-G3□20P4 to -G3□21P5)</p>	<p>3HP, 5HP (2.2kW, 3.7kW) CIMR-G3□22P2, -G3□23P7)</p>	<p>7.5HP, 10HP (5.5kW, 7.5kW) (CIMR-G3□25P5, -G3□27P5)</p>	
<p>15HP (11kW) (CIMR-G3□2011)</p>	<p>20HP (15kW) (CIMR-G3□2015)</p>	<p>25HP, 30HP (18.5kW, 22kW) (CIMR-G3□2018, -G3□2022)</p>	
<p>40HP (30kW) (CIMR-G3□2030)</p>	<p>50HP (37kW) (CIMR-G3□2037)</p>	<p>60HP, 75HP (45kW, 55kW) (CIMR-G3□2045, -G3□2055)</p>	
<p>100HP (75kW) (CIMR-G3□2075)</p>			

Panel Cut for External Installation of Cooling Fin (Cont'd)

380 to 460V

Dimensions in inch (mm)

0.5 to 3HP (0.4 to 2.2kW) (CIMR-G3□40P4 to -G3□42P2)	5 to 10HP (3.7kW to 7.5 kW) (CIMR-G3□43P7 to -G3□47P5)	15HP, 20HP (11kW, 15kW) (CIMR-G3□4011, -G3□4015)
25HP, 30HP (18.5kW, 22kW) (CIMR-G3□4018, -G3□4022)	40 to 60HP (30 to 45kW) (CIMR-G3□4030 to -G3□4045)	60HP (45kW) (CIMR-G3□4L45)
60HP, 100HP (55kW, 75kW) (CIMR-G3□4L55, -G3□4L75)	150HP (110kW) (CIMR-G3□4LA1)	200HP (160kW) (CIMR-G3□4LA6)
250HP, 300HP (185kW, 220kW) (CIMR-G3□4185, -G3□4220)	400HP (300kW) (CIMR-G3□4300)	

500 to 600V

Dimensions in inch (mm)

<p>2HP, 3HP (1.5kW, 2.2kW) (CIMR-G3□51P5, -G3□52P2)</p> <p>Technical drawing of a 2HP/3HP panel cut. Dimensions include 13.19 (335) height, 8.05 (204.5) width, and 7.76 (197) cutout width. Features include a gasket and 4-0 276 (7) DIA MTG HOLE.</p>	<p>5 to 10HP (3.7 to 7.5kW) CIMR-G3□53P7 to -G3□57P5)</p> <p>Technical drawing of a 5 to 10HP panel cut. Dimensions include 13.19 (335) height, 8.05 (204.5) width, and 7.76 (197) cutout width. Features include a gasket and 4-0 276 (7) DIA MTG HOLE.</p>	<p>15HP (11kW) (CIMR-G3□5011)</p> <p>Technical drawing of a 15HP panel cut. Dimensions include 21.14 (537) height, 12.80 (325) width, and 11.85 (301) cutout width. Features include 4-MTG HOLE FOR M6 SCREW and 2-0 189 DIA (M4) MTG HOLE.</p>
<p>20 to 30HP (15 to 22kW) (CIMR-G3□5015 to -G3□5022)</p> <p>Technical drawing of a 20 to 30HP panel cut. Dimensions include 26.2 (665) height, 15.7 (400) width, and 15.0 (382) cutout width. Features include 4-0 394 DIA (M8) MTG HOLE and 2-0 189 DIA (M4) MTG HOLE.</p>	<p>40 to 60HP (30 to 45kW) (CIMR-G3□5030 to -G3□5045)</p> <p>Technical drawing of a 40 to 60HP panel cut. Dimensions include 29.9 (760) height, 22.6 (575) width, and 20.6 (525) cutout width. Features include 4-0 472 DIA (M10) MTG HOLE and 4-0 189 DIA (M4) MTG HOLE.</p>	<p>75HP, 100HP (55kW, 75kW) (CIMR-G3□5055, -G3□5075)</p> <p>Technical drawing of a 75HP/100HP panel cut. Dimensions include 37.8 (960) height, 22.6 (575) width, and 20.6 (522) cutout width. Features include 4-0 472 DIA (M10) MTG HOLE and 4-0 189 DIA (M4) MTG HOLE.</p>
<p>120HP (90kW) (CIMR-G3□5090)</p> <p>Technical drawing of a 120HP panel cut. Dimensions include 46.7 (1180) height, 22.6 (575) width, and 20.6 (522) cutout width. Features include 4-0 189 DIA (M4) MTG HOLE and 4-0 472 DIA (M10) MTG HOLE.</p>	<p>150HP, 200HP (110kW, 160kW) (CIMR-G3□5110, -G3□5160)</p> <p>Technical drawing of a 150HP/200HP panel cut. Dimensions include 58.7 (1490) height, 22.6 (575) width, and 20.6 (525) cutout width. Features include 4-0 189 DIA (M4) MTG HOLE and 4-0 591 DIA (M12) MTG HOLE.</p>	

Digital Operator for Easy Operation (Provided as Standard)

Functions of the digital operator

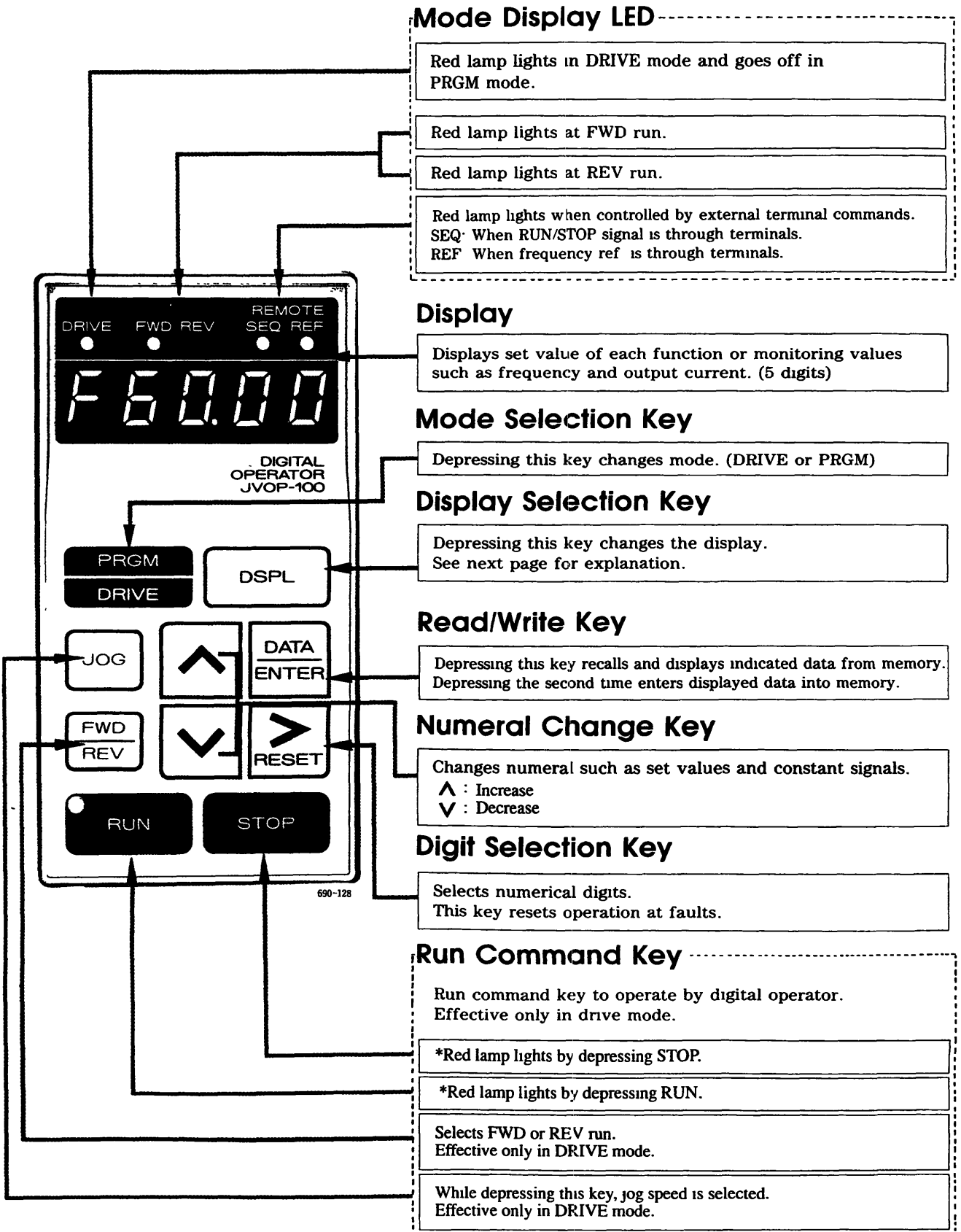

• Integrated monitoring facility guarantees safe operation

Un-□□	Monitor Item	LED Indication
01	Frequency Reference	F 60.00
02	Output Frequency	60.00
03	Output Current	12.5A
04	Voltage Command	200V
05	D.C. Voltage (VPN)	Pn270
06	Output Power (± display)	- 2.5
07	Status of Input Terminal	CHHHH
08	Status of Output Terminal	o 11
09	Check of LED	88888
10	PROM No.	10013

• Example of operation with digital operator (with preset factory setting)

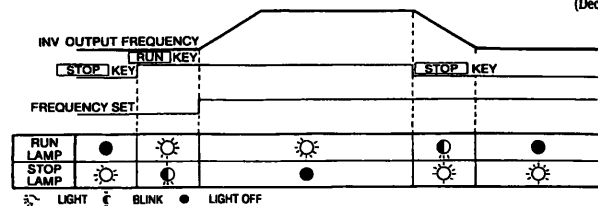
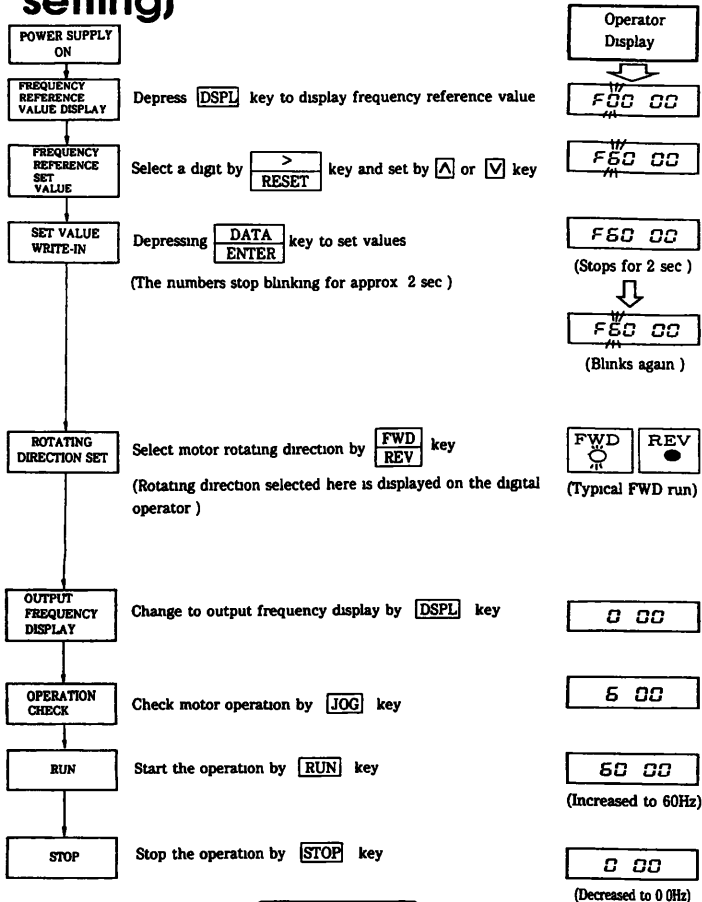

The RUN and STOP lamps goes on/off and blinks according to operation state.

• Monitor Items Display Procedure

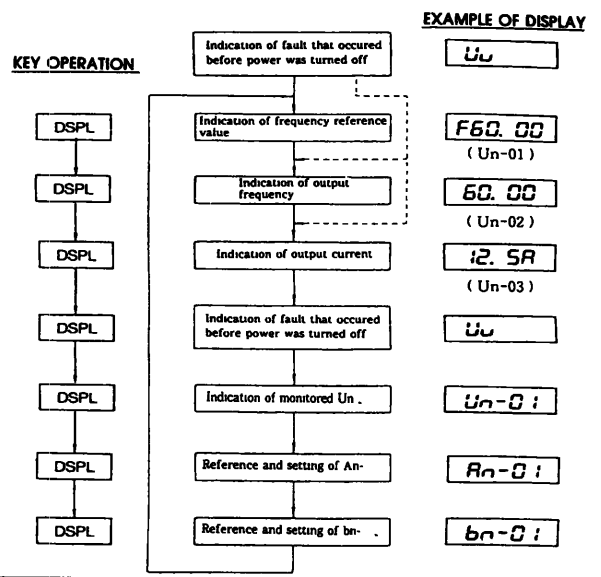

• Switching between the DRIVE/PRGM (program) Mode (The mode can be switched only when the machine is stopped.)

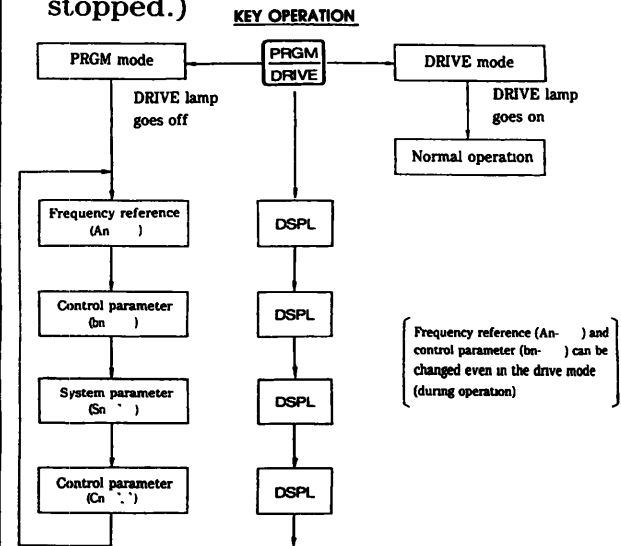

• Changing the Control Parameter

Example of change of system parameter Sn-04

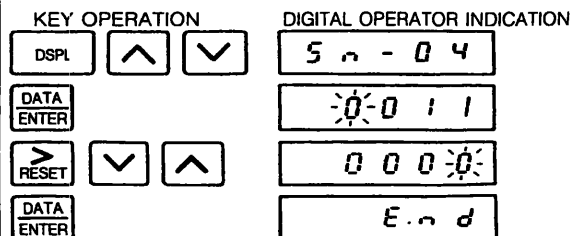

Versatile Software Menu Helps Hi-tech Implementation of Your Machine

SYSTEM CONSTANT Sn- [] [] []

[]: Set before operation.

Function	Sn- [] [] []	Data Name	Function	Factory Setting				
				4th digit	3rd digit	2nd digit	1st digit	
Inverter Capacity	01	Inverter Capacity	Inverter capacity selected*	-				
	02	V/f	V/f pattern selected	0 0				
Operator Status	03	Display of Operator	0000 Setting and reading of AN-000, bn-000, Sn-000, Cn-000 enabled 0101 Setting and reading of AN-000; reading of bn-000, Sn-000, Cn-000 enabled	0 0 0 0				
		Constants Initialization	1110 NVRAM initialization (Multi-function terminals are set prior to shipping) 1111 NVRAM initialization (3 WIRE sequence)	0 0 0 0				
Run Mode Selection 1	04	Operation Method Select	Master frequency reference by analog input of external terminals 13, 14	4th digit	3rd digit	2nd digit	1st digit	0 0 1 1
			Master frequency reference from keypad	-	-	-	0	
			External terminal operation effective (start/stop, etc)	-	-	0	-	
			Keypad operation effective	-	-	1	-	
		Stopping Method Select	RAMP stop	0	0	-	-	
			Coasting to stop	0	1	-	-	
			Full-range DC injection braking stop	1	0	-	-	
			Coasting stop (timer function provided) (Set time by bn-02.)	1	1	-	-	
Run Mode Selection 2	05	Priority of Stopping	Keypad STOP key effective during operation	-	-	-	0	0 0 0 0
			Keypad STOP key not effective during operation	-	-	-	1	
		Prohibition of REV run	REV run enabled	-	-	0	-	
			REV run disabled	-	-	1	-	
Control Input Scan	Control input are scanned twice before being accepted by MPU.	-	0	-	-			
	Control input are scanned once before being accepted by MPU.	-	1	-	-			
Multi-function Analog Monitor Output*	Selection of analog output (terminals 21-22).	0	-	-	-			
	Selection of analog output (terminals 21-22).	1	-	-	-			
Run Mode Selection 3	06	S-curve at accel/decel time	0.2 sec. S-curve	-	-	0	0	0 0 0 0
			No S-curve	-	-	0	1	
			0.5 sec. S-curve	-	-	1	0	
			1.0 sec. S-curve	-	-	1	1	
		Input Reference	Response to master frequency reference : 0 to 100% for 0 to 10V (4 to 20mA)	-	0	-	-	
			Response to master frequency reference : 0 to 100% for 10 to 0V (20 to 4mA)	-	1	-	-	
Processing When Frequency Reference is Missing	Stop by reference input loss	0	-	-	-			
	Operation to continue with 80% of frequency reference	1	-	-	-			
Run Mode Selection 4	07	Overtorque Detection	Overtorque detection not enabled	-	-	-	0	0 0 0 0
			Overtorque detection enabled	-	-	-	1	
			Enabled only if at set speed	-	-	0	-	
			Enabled during operation (except during DC injection)	-	-	1	-	
			Operation continued after overtorque is detected	-	0	-	-	
			Coasts to stop of overtorque is detected	-	1	-	-	
Not used	0	-	-	-				
Run Mode selection 5	08	Run Selection	Run by frequency reference input (option)	-	-	-	0	0 1 0 0
			Run by inverter operator or control circuit terminal input run command input	-	-	-	1	
			Run by run command input (option)	-	-	0	-	
			Run by inverter operator or control circuit terminal input run command input	-	-	1	-	
		Stopping Method Selection of Communication Interface Card (SI-B) Communication Error	Ramp to a stop (decel time: bn-02)	0	0	-	-	
			Coasting to a stop	0	1	-	-	
Operation to continue	Ramp to a stop (decel time: bn-04)	1	0	-	-			
	Operation to continue	1	1	-	-			
Run Mode Selection 6	09	Multi-function Analog Monitor output*	Item to analog output (terminals 21-22) depends on Sn-05 4th digit and Sn-09 2nd digit setting	-	-	-	0	0 0 0 0
			Item to analog output (terminals 21-22) is set by communication interface card (SI-B)	-	-	-	1	
			Selection of analog output (terminals 21-22)	-	-	0	-	
			Selection of analog output (terminals 21-22)	-	-	1	-	
-	-	-	0	0	-	-		

* When Sn-09 1st-digit is 0, analog output (terminals 21-22) is as follows:

Sn-05 4th digit	Sn-09 2nd digit	Output
0	0	Output frequency
1	0	Output current
0	1	Output voltage reference
1	1	Output power

SYSTEM CONSTANT Sn- [][]

□ : Set before operation.

Function	Sn- [][]	Data Name	Function	Factory Setting			
				4th digit	3rd digit	2nd digit	1st digit
Protection Section 1 (stall prevention)	10	Stall Prevention	Stall prevention during acceleration enabled	-	-	-	0
			Stall prevention during acceleration disabled	-	-	-	1
			Stall prevention during deceleration enabled	-	-	0	-
			Stall prevention during deceleration disabled	-	-	1	-
			Stall prevention during running enabled	-	0	-	-
			Stall prevention during running disabled	-	1	-	-
			Decel time during stall prevention "DECEL TIME 1" (bn-02 set value) Decel time during stall prevention "DECEL TIME 2" (bn-04 set value)	0 1	- -	- -	- -
Protection Section 2	11	DB resistor	No DB protection calculated or provided by inverter	-	-	-	0
			Protection provided for Yaskawa internal DB resistor only, if installed	-	-	-	1
		Fault Contact during Auto Reset / Restart Operation	Fault contact is not energized during auto reset/restart operation	-	-	0	-
			Fault contact is energized during auto reset/restart operation	-	-	1	-
		Momentary Power Loss Protection	Operation stopped by momentary power loss detection	-	0	-	-
Operation continues during momentary power loss	-	1	-	-			
Protection Section 3	12	External Fault Signal Level	External fault input ; Normal open-contact input	-	-	-	0
			External fault input , Normal closed-contact input	-	-	-	1
		Receiving External Fault Signal	External fault signal , always detected	-	-	0	-
			External fault signal , detected while running only	-	-	1	-
		Processing of External Fault Detection	Ramp stop (major fault)	0	0	-	-
			Coasting to stop (major fault)	1	1	-	-
			Emergency stop (major fault) decelerates to stop by emergency stop time(bn-04 set value)	1	0	-	-
Operation to continue (minor fault)	1	1	-	-			
Protection Section 4	13	Stopping Method at Fan Fault Detection*	Deceleration to stop (decel time bn-02)	0	0	-	-
			Coasting to stop	0	1	-	-
			deceleration to stop (decel time bn-04)	1	0	-	-
			Operation to continue	1	1	-	-
Protection Section 5	14	Motor Protection (Electronic Thermal)	Electronic thermal motor Protection effective	-	-	-	0
			Electronic thermal motor Protection ineffective	-	-	-	1
			Electronic thermal characteristics in accordance with standard motor	-	-	0	-
			Electronic thermal characteristics in accordance with constant torque motor	-	-	1	-
			Electronic thermal characteristics are standard.	-	0	-	-
		Electronic thermal characteristics are short-time rating	-	1	-	-	
		Inverter Protection (Electronic Thermal)	Inverter Protection OL 103% continuous (Rated torque mode) 150% for one minute	0	-	-	-
			Inverter Protection OL 113% continuous (Reduction torque mode) 123% for one minute	1	-	-	-
Multi-Function Selection	15-22	Input Signal	00-FF Selects terminal 5 function (factory set for multi-step speed reference 1)	-	-	-	0 3
			00-FF Selects terminal 6 function (factory set for multi-step speed reference 2)	-	-	-	0 4
			00-FF Selects terminal 7 function (factory set for jog frequency reference)	-	-	-	0 6
			00-FF Selects terminal 8 function (factory set for internal baseblock by NO contact input)	-	-	-	0 8
		Analog Input	00-FF Selects multi-function analog input (terminal 16) function	-	-	-	0 0
		Output Signal	00-FF Selects multi-function contact output (terminals 9, 10) function (factory set for during running)	-	-	-	0 0
00-FF Selects multi-function open collector (terminal 25) function (factory set for zero speed)	-		-	-	0 1		
Option Card Function Section	25	Analog Reference Card (AI - 14B)	Positive / negative values of frequency reference determine FWD / REV operation	-	-	-	-
			Positive frequency reference value determine forward operation negative = 0 output	-	-	-	-
			Not used	0	0	0	-
	26	Digital Reference Card (DI - 08) (Frequency reference set mode)	BCD input 1% Resolution	0	0	0	0
			BCD input 0.1% Resolution	0	0	0	1
			BCD input 0.01% Resolution	0	0	1	0
			BCD input 1 Hz Resolution	0	0	1	1
			BCD input 0.1 Hz Resolution	0	1	0	0
			BCD input 0.01 Hz Resolution	0	1	0	1
			BINARY input 255 / 100%	0	1	1	1
	BINARY input (input value displayed in decimal on operator)	1	0	0	0		
	27	Digital Output Card (DO-08)†	Output content depends on 1-st digit setting "1" or "0"	-	-	-	-
			1 F	0	0	0	-
			6 F	0	0	1	-
10 F			0	1	0	-	
12 F			0	1	1	-	
36 F	1	0	0	-			
28	Analog Monitor Card (AO - 08, AO - 12)	Channel 1 output	Output frequency (max frequency / 100%)	-	-	0	0
			Output current (rated current / 100%)	-	-	0	1
			Output voltage ref (Input voltage / 100%)	-	-	1	0
			DC voltage (400V / 100% for 200V class 800V / 100% for 400V class)	-	-	1	1
			Not used	0	0	0	-
		Channel 2 output	Output frequency (max frequency / 100%)	0	0	-	-
			Output current (rated current / 100%)	0	1	-	-
			Output voltage ref (Input voltage / 100%)	1	0	-	-
			DC voltage (400V / 100% for 200V class 800V / 100% for 400V class)	1	1	-	-
			Not used	0	0	0	-

* Effective only for inverter models of capacity 200V class 40HP (30kW) or more, 400V class 75HP (55kW) or more, or 575V class 30HP (22kW) or more
 † For more information, refer to "Digital Output Card DO-08" Instructions (TOE-C736-30 24)

CONTROL CONSTANT Cn - [] [] [] []

[] : Set before operation.

Function	Cn-[] [] [] []	Data Name	Set Unit	Set Range	Factory Setting
V / f pattern Setting	01	Input voltage	0.1 V	0.0-255.0V (200V) 0.0-510.0V (400V)	230.0V (200V) 460.0V (400V)
	02	Max. frequency	0.1 Hz	50.0-400.0 Hz	60.0 Hz
	03	Max. voltage	0.1 V	0.0-255.0V (200V) 0.0-510.0V (400V)	200.0V (200V) 400.0V (400V)
	04	Max. voltage frequency	0.1 Hz	0.1-400.0 Hz	60.0 Hz
	05	Mid. output frequency	0.1 Hz	0.1-400.0 Hz	3.0 Hz
	06	Mid. output frequency voltage	0.1 V	0.0-255.0V (200V) 0.0-510.0V (400V)	15.0 V (200V) 30.0 V (400V)
	07	Min. output frequency	0.1 Hz	0.1-400.0 Hz	1.5 Hz
	08	Min. output frequency voltage	0.1 V	0.0-255.0V (200V) 0.0-510.0V (400V)	10.0 V (200V) 20.0 V (400V)
Electronic thermal Overload relay ref. Current	09	Motor rated current	0.1 A	*1	*2
DC Injection Braking	10	DC injection braking start frequency	0.1 Hz	0.1-10.0 Hz	1.5 Hz
	11	DC injection braking current	1 %	0-100 % *4	50 %
	12	DC injection braking time at stopping	0.1 sec	0.0-25.5 sec	0.5 sec
	13	DC injection braking time at starting	0.1 sec	0.0-25.5 sec	0.0 sec
Freq. Limit Control	14	Frequency (speed) reference upper limit	1 %	0-109 %	100 %
	15	Frequency (speed) reference lower limit	1 %	0-109 %	0 %
Freq. Jump Control	16	Setting prohibit frequency 1	0.1 Hz	0.0-400.0 Hz	0.0 Hz
	17	Setting prohibit frequency 2	0.1 Hz	0.0-400.0 Hz	0.0 Hz
	18	Setting prohibit frequency 3	0.1 Hz	0.0-400.0 Hz	0.0 Hz
	19	Setting prohibit frequency range	0.1 Hz	0.0-25.5 Hz	1.0 Hz
Operator Display Change	20	Operator display mode	1	0-39999	0
Speed Agreed Detection	21	Up-to desired frequency setting	0.1 Hz	0.0-400.0 Hz	0.0 Hz
	22	Up-to frequency setting detection width	0.1 Hz	0.0-25.5 Hz	2.0 Hz
Carrier Freq. Adjustment	23	Carrier frequency upper limit	0.1 kHz	0.4-15.0 kHz	15.0 kHz
	24	Carrier frequency lower limit	0.1 kHz	0.4-15.0 kHz	15.0 kHz
	25	Carrier frequency proportional gain	1	0-99	0
Overtorque Detection	26	Overtorque detection level	1 %	30-200 %	160 %
	27	Overtorque detection time	0.1 sec	0.0-25.5 sec	0.1 sec
Stall Prevention	28	Stall prevention level during acceleration	1 %	30-200 %	170 %
	29	Constant HP area stall prevention limiter	1 %	30-200 %	50 %
	30	Stall prevention level during running	1 %	30-200 %	160 %
Torque Boost Control	31	Motor terminal resistance (Motor phase to phase resistance)	0.001 Ω	0.000-65.535 Ω	*2
	32	Motor iron loss	1 W	0-65535 W	*2
	33	Torque compensation limiter	1 V	0-50V (200V) 0-100V (400V)	*2
Simple Speed Control	34	Motor no-load current	1 %	0-99 % *3	30 %
	35	Slip compensation primary delay time	0.1 sec	0.0-25.5 sec	2.0 sec
Automatic reset & restart operation	36	No. of auto restart attempt	1	0-10	0
Momentary Power Loss	37	Momentary power loss ride through time	0.1 sec	0.0-2.0 sec	*2
	38	Speed search deactivation current level	1 %	0-200 %	150 %
Speed Search Control	39	Speed search decel time *5	0.1 sec	0.0-25.5 sec	2.0 sec
	40	Min. baseblock time	0.1 sec	0.5-5.0 sec	*2
	41	V / f during speed search	1 %	0-100 %	100 %
	42	Voltage recovery time	0.1 sec	0.1-2.0 sec	0.3 sec

*1 Set in a range of 10 to 200% of inverter rated current.

*2 Factory setting differs depending on inverter capacity (Sn-01 set value).

*3 Motor rated current (Cn-09) is set as 100% level.

*4 For set value ≤ 50% : carrier frequency = 8 kHz

For set value > 50% : carrier frequency = 1 kHz

*5 If set to zero, speed search will be disabled.

FREQUENCY REFERENCE An - [] [] []

These references are used during multi-speed operation. Set values of AN-[] [] [] can be changed or read during running in DRIVE mode.

[] : Set before operation.

An - [] [] []	Data Name	Unit	Setting Range	Factory Setting
01	Frequency reference 1	0.01 Hz	0.00 Hz—400.00 Hz	0.00 Hz
* 02	Frequency reference 2	0.01 Hz	0.00 Hz—400.00 Hz	0.00 Hz
03	Frequency reference 3	0.01 Hz	0.00 Hz—400.00 Hz	0.00 Hz
04	Frequency reference 4	0.01 Hz	0.00 Hz—400.00 Hz	0.00 Hz
05	Frequency reference 5	0.01 Hz	0.00 Hz—400.00 Hz	0.00 Hz
06	Frequency reference 6	0.01 Hz	0.00 Hz—400.00 Hz	0.00 Hz
07	Frequency reference 7	0.01 Hz	0.00 Hz—400.00 Hz	0.00 Hz
08	Frequency reference 8	0.01 Hz	0.00 Hz—400.00 Hz	0.00 Hz
09	Jog Frequency reference	0.01 Hz	0.00 Hz—400.00 Hz	6.00 Hz

Note. An - [] [] [] setting/reading units can be changed according to operator display mode (Cn-20) set values.

The set unit at factory setting is 0.01 Hz

* SN - 19 must be set to "0F".

CONSTANT TO CHANGE DURING RUNNING Bn - [] [] []

Set values of bn - [] [] [] can be changed or read during running in DRIVE mode.

[] : Set before operation.

bn - [] [] []	Data Name	Unit	Setting Range	Factory Setting
01	Acceleration time 1	0.1 Sec	0.0—6000.0 Sec	10.0 Sec
02	Deceleration time 1	0.1 Sec	0.0—6000.0 Sec	10.0 Sec
03	Acceleration time 2	0.1 Sec	0.0—6000.0 Sec	10.0 Sec
04	Deceleration time 2	0.1 Sec	0.0—6000.0 Sec	10.0 Sec
05	Frequency reference gain	0.1 %	0—1000.0%	100 %
06	Frequency reference bias	1 %	-100 to 100%	0 %
07	Torque compensation gain	0.1	0.0—2.0	1.0
08	Motor rated slip	0.1 %	0.0—9.9 %*1	0.0 %
09	Energy-saving level gain	1 %	0—200 %	80 %
10	Monitor No. after turning on power supply	—	1—3	1
11	Gain of analog output (ter. 21 and 22) and gain of channel 1 of option card if installed	0.01	0.00—2.55*3	1.00
12	Gain of channel 2 of option card if installed*2	0.01	0.00—2.55*3	0.5

*1 Cn-04 is regarded as 100% level

*2 Effective for the installation of option cards A0—08 and A0—12.

*3 When EPROM No. is NSG610010—NSG610012, the contents become as in the table below.

When EPROM No. is NSG610030 or more, gains can be set to max. 2.0.

11	Analog monitor channel 1 gain	1 %	0—255 %	100 %
12	Analog monitor channel 2 gain	1 %	0—255 %	200 %

Select Functions and Parameters for Optimal Operation

Inverter capacity setting

Item name	Parameter to be set	Factory Preset
Inverter capacity	Sn-01	See table below

Inverter capacity is preset at the factory. Refer to the table below and reset when using spare PC boards, etc. An incorrect data input may cause inverter fault.

200 to 230V

Sn-01 Data	00	01	02	03	04	05	06	07
CIMR-G3□□	20P4	20P7	21P5	22P2	23P7	25P5	27P5	2011
	08	09	0A	0B	0C	0D	0E	0F
	2015	2018	2022	2030	2037	2045	2055	2075

380 to 460V

Sn-01 Data	20	21	22	23	24	25	26	27
CIMR-G3□□	40P4	40P7	41P5	42P2	43P7	45P5	47P5	4011
	28	29	2A	2B	2C	2D	3F	2E
	4015	4018	4022	4030	4037	4045	4145	4055
	2F	30	31	32	33	34	35	36
	4075	4090	4110	4132	4160	4185	4220	4300

500 to 575V

Sn-01 Data	42	43	44	45	46	47	48	49
CIMR-G3□□	51P5	52P2	53P7	55P5	57P5	5011	5015	5018
	4A	4B	4C	4D	4E	4F	50	51
	5022	5030	5037	5045	5055	5075	5090	5110
	52							
	5160							

V/f characteristics

Item name	Parameter to be set	Factory Preset
V/f selection	Sn-02	0 1
V/f parameter	Cn-02 to 08	See page 52.

There are 15 patterns available. Optimum selection requires consideration of the load characteristics. Optional V/f pattern setting (Sn-02 = "0F") allows programming of custom V/f patterns below.

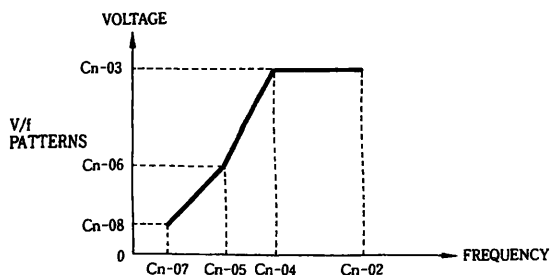

Operation mode selection

Item name	Parameter to be set	Factory Preset
Operator status	Sn-03	0 0 0 0
Start/stop procedure	Sn-04	0 0 1 1
Operation mode selection	Sn-05	0 0 0 0

- **Constant write disable**
Prevents operation error.

$$\text{Sn-03} = 0101$$

- **Constant initialization**
Allows all constants to be set except Sn-01 and Sn-02 which are preset at the factory.

$$\text{Sn-03} = 1110$$

- **Analog output (Terminals 21 and 22) selection**
With the combination of 4th digit of Sn-05 and 2nd digit of Sn-09, the output will be as follows:

4th digit of Sn-05	2nd digit of Sn-09	Output
0	0	Output freq.
1	0	Output Current
0	1	Voltage ref.
1	1	Output power

- **Start/stop procedure**
Control input can be selected from the digital operator or the terminal strip.

$$\text{Sn-04} = \times \times 00$$

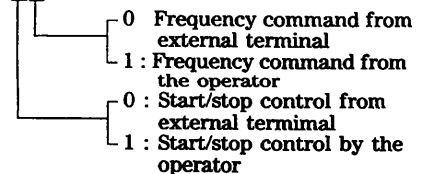

- **Stop procedure**
Stopping mode can be selected according to the application.

$$\text{Sn-04} = 00 \times \times$$

- 00 : Ramp to a stop
- 01 : Coasting to a stop
- 10 : Full-range DB stop
- 11 : Coasting to a stop, restart with timer (Restartable after the deceleration time set in bn-02 elapses.)

- **Reverse rotation prevention**
Prevents accidental selection of reverse rotation. With this mode selected, reverse rotation command is not effective.

$$\text{Sn-05} = \times \times 1 \times$$

Accel/decel time and patterns

Item name	Parameter to be set	Factory Preset
V/f Pattern choice	Sn-06	0 0 0 0
Acceleration time 1	bn-01	10.0s
Deceleration time 1	bn-02	10.0s
Acceleration time 2	bn-03	10.0s
Deceleration time 2	bn-04	10.0s

- **S-curve non-linear accel/decel is possible.**
Reduce shocks at accel/decel time.

Sn-06 = × 0 × ×

00 : 0.2 sec of non-linear accel/decel
 01 : 0 sec of non-linear accel/decel
 10 : 0.5 sec of non-linear accel/decel
 11 : 1.0 sec of non-linear accel/decel

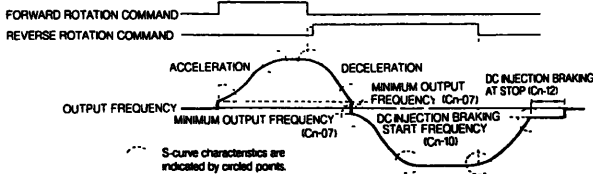

Note: S-curve characteristics are not enabled at completion of deceleration when the first and second digits are 00.

- Each item can be set from 0.0 sec to 6000.0 sec.
The set time indicates the interval required before the maximum output frequency (Cn-02) is reached.

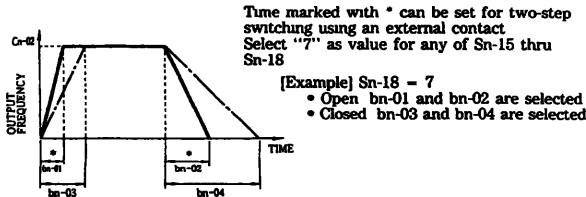

Operation mode when frequency command is missing

Item name	Parameter to be set	Factory Preset
Operation signal selection 3	Sn-06	0 0 0 0

When analog frequency command is lost, operation will be continued at 80% of the speed specified by the preceding frequency command.
Set as follows:

Simple backup is provided when an error occurs in the host computer.

Sn-06 = 0 × × ×

0 : Function not effective
 1 : Function effective

Frequency command characteristics

Item name	Parameter to be set	Factory Preset
Operation signal selection 3	Sn-06	0 0 0 0

Frequency command input characteristics can be set as follows:

Sn-06 = × 0 × ×

0 : Direct response
 1 : Indirect response

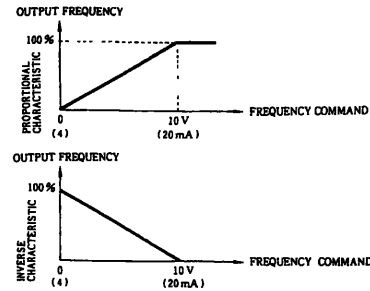

Overtorque detection

Item name	Parameter to be set	Factory Preset
Overtorque detection selection	Sn-07	See page 50.
Overtorque detection level	Cn-26	160%
Overtorque detection time	Cn-27	0.1s
Overtorque detection signal	Sn-20 to 22	See page 51.

When excess load is placed on the machine, the increase in motor current is detected and an alarm signal may be output.

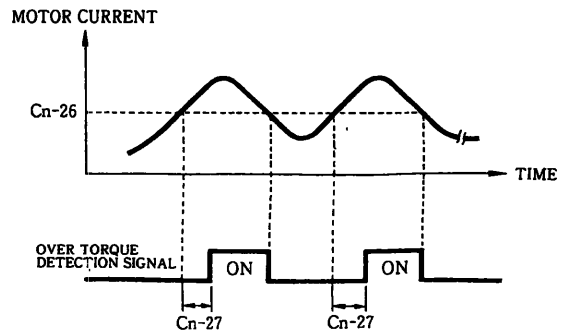

To use this function, set "0B" for any constant from Sn-20 to Sn-22.

Motor stall prevention

Item name	Parameter to be set	Factory Preset
Operation level for stall prevention during deceleration	Sn-10	0 0 0 0
Operation level for stall prevention during acceleration	Cn-28	170%
Operation level for stall prevention during operation	Cn-30	160%

Automatically adjusts output frequency according to the load so as to continue operation of the machine without stalling the motor.

• Stall prevention during acceleration

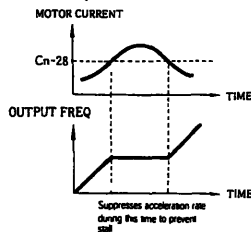

• Stall prevention during operation

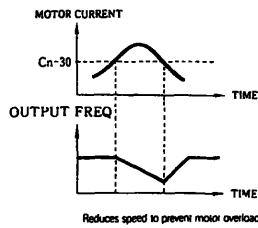

• Stall prevention during deceleration

Sn-10 = × × 0 × ×
 0 : Stall prevention during deceleration enabled
 1 : Stall prevention during deceleration disabled

Note: Set to "1" when connecting braking resistor unit.

Built-in braking resistor protection

Item name	Parameter to be set	Factory Preset
Regenerative braking resistor protection	Sn-11	0 0 0 0

Built-in braking resistors are protected by thermal simulation. When a built-in braking resistor is used, select × × × 1 (protection effective).

When an external braking resistor unit is used, set × × × × 0, and protect the resistor unit with the built-in thermal relay. The thermal relay should be wired in series with the inverter run command or the external fault circuit.

Sn-11 = × × × 0 × ×
 0 : Not protected
 1 : Protected

Operation during momentary power loss

Item name	Parameter to be set	Factory Preset
Function enabled/disabled	Sn-11	0 0 0 0
Compensating time for momentary power loss	Cn-37	0.7s

Operation can be continued even when a momentary power loss occurs.

* Example of model CIMR-G3A2 0P4

Sn-11 = × 0 × × ×

0 : Continuation function disabled
 1 : Continuation function enabled

Set compensation time (up to 2 sec) for Cn-37. For motors of 3HP (2.2 kW) capacity or below, the compensating time is 0.5 sec to 1 sec. If longer momentary power loss ride-thru is required, install back-up capacitor unit (optional for small unit).

External error stop mode

Item name	Parameter to be set	Factory Preset
Protection characteristic selection 3	Sn-12	0 1 0 0

Stop method after external error (when external terminal 3 receives input) can be set as follows:

Sn-12 = 00 × × ×

00 : Frequency deceleration (bn-02)
 01 : Coasting to a stop
 10 : Frequency deceleration (bn-04)
 11 : Operation continued

Electronic thermal overload

Item name	Parameter to be set	Factory Preset
Motor type	Sn-14	0 0 0 0
Motor rated current	Cn-09	1.9A*

The electronic thermal overload function prevents standard motors from overloading when the speed is reduced by the inverter. (No external thermal switch is necessary.) Set as follows:

Sn-14 = 0 0 0 × ×

0 : Standard motors
 1 : Inverter controlled motors
 0 : Motor time constant 8min.
 1 : Motor time constant 5min.
 0 : Inverter protection constant torque mode
 1 : Inverter protection HVAC mode

Electronic thermal protection can be displayed by setting " **Sn-14** = × × × 1."

*The example represents YASKAWA 0.5HP (0.4kW), 200V, 4-pole motor. For motors of other manufacturers, set the nameplate value of the motor.

Pulse monitor selection (option)

Item name	Parameter to be set	Factory Preset
Pulse frequency selection	Sn-27	0 0 1 0

With a digital counter connected, speed can be indicated as a pulsed output. The following output pulse frequencies can be selected:

Sn-27 = 0000

- 000 : Output frequency × 1
- 001 : Output frequency × 6
- 010 : Output frequency × 10
- 011 : Output frequency × 12
- 100 : Output frequency × 36

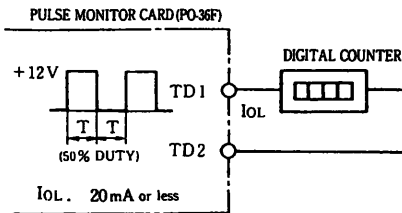

Analog monitor selection (option)

Item name	Parameter to be set	Factory Preset
Analog monitor selection	Sn-28	0100
Channel 1 gain	bn-11	1.00
Channel 2 gain	bn-12	0.50

Various monitors available with the connection of an analog meter. Also meter calibration is possible with internal constants **bn-11** and **bn-12**.

Sn-28 = 0100

- Channel 1 output
 - 00: Output frequency
 - 01: Output current
 - 10: Output voltage ref.
 - 11: DC voltage
- Channel 2 output
 - 00: Output frequency
 - 01: Output current
 - 10: Output voltage ref.
 - 11: DC voltage

Input voltage setting

Item name	Parameter to be set	Factory Preset
Input voltage set	Cn-01	200V

Input voltage set **Cn-01** provides optimum torque outputs.

DC injection braking

Item name	Parameter to be set	Factory Preset
DC injection during stop	Cn-10, 12	See page 52.
DC injection at start	Cn-07, 11, 13	See page 52.
DC injection braking external control	Sn-15 to 18	See page 51.

• DC injection braking during stop

Prevents overrun at stop.
(Exact position stop)

• Starting DC injection braking during start

Stops a coasting motor without tripping even when the direction of rotation is unknown.

• DC injection braking external control

Controls DC injection braking (during coasting to a stop). Set "60" for any of Sn-15 to Sn-18. When run command is removed, and motor is coasting, full range DC injection braking occurs.

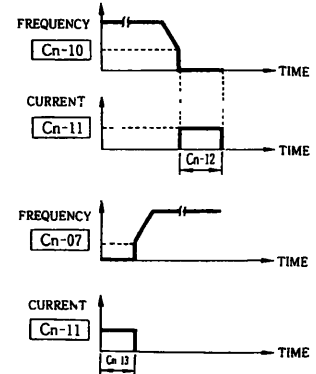

Output frequency limit

Item name	Parameter to be set	Factory Preset
Frequency (speed) command upper limit	Cn-14	100%
Frequency (speed) command lower limit	Cn-15	0

The upper and lower limits for the output frequency can be clamped. When the lower limit is not 0, acceleration to that lower limit setpoint begins immediately when the start command is input.

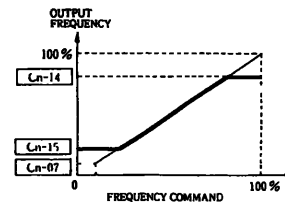

Resonant frequency jump control

Item name	Parameter to be set	Factory Preset
Prohibited frequency 1-3	Cn-16 to 18	0.0 Hz
Prohibited frequency range	Cn-19	1.0 Hz

Operation at the preset frequency will be eliminated. The inverter will accel/decel through the prohibited region. This function is used to avoid resonant frequencies in the mechanical systems.

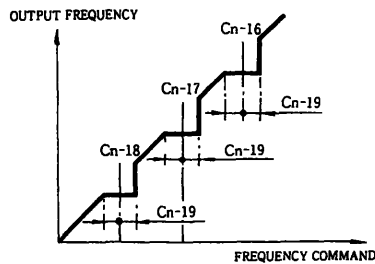

r/min indication (monitoring)

Item name	Parameter to be set	Factory Preset
Operator monitor indication	Cn-20	0

The unit of speed indicated on the operator can be switched from the following: Hz, r/min, m/min, %, or any other directly proportional value.

[Example] **Cn-20** = 0 : Hz display
 1 : % display
 Number of motor poles : r/min display
 Other units with an arbitrary number of digits such as m/min and m³/min can be used.

Carrier frequency

Item name	Parameter to be set	Factory Preset
Carrier frequency upper limit	Cn-23	15.0kHz
Carrier frequency lower limit	Cn-24	15.0kHz
Carrier frequency proportional gain	Cn-25	0

Changing the carrier frequency reduces RFI noise and leakage current without increasing motor noise. When Cn-25 is 6 or below, carrier frequency is value set at Cn-23.

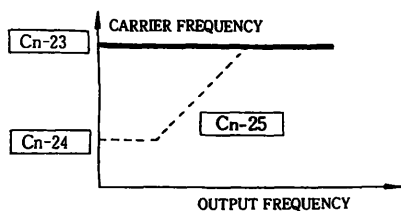

Automatic reset and restart

Item name	Parameter to be set	Factory Preset
Retry counts	Cn-36	0

If an inverter error occurs during operation, the inverter performs self diagnosis and automatically restarts.

Up to 10 retry counts can be set for **Cn-36**.

9-step speed change

Item name	Parameter to be set	Factory Preset
Multi-speed frequency command	An-01 to 09	See page 53.
Multi-function command	Sn-15 to 18	See page 51
Run selection	Sn-04	0 0 1 1
Multi-function analog input	Sn-19	0 0

Up to 9 steps of speeds can be set using signals from external terminals 5 to 8. This eliminates the need for an analog signal, thereby enabling simplified external control operation. See the following example.

- Set An-01 to -09 according to run specifications.
- Set Sn-04 = $x \times x \times 1$, Sn-19 = OF.

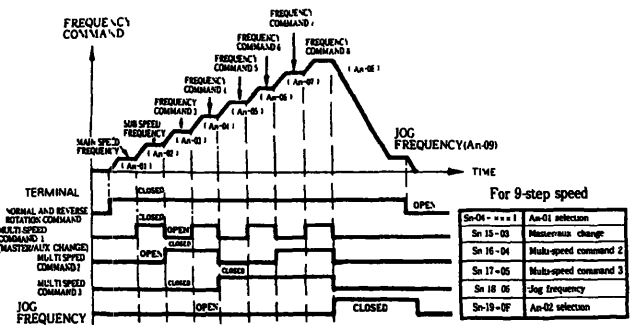

Jog operation

Item name	Parameter to be set	Factory Preset
Jog frequency	An-09	6.00 Hz

Select the jog mode (connect terminals 11 and 7) and input the start signal. Inching starts.

Depressing the **JOG** key on the digital operator performs the same operation.

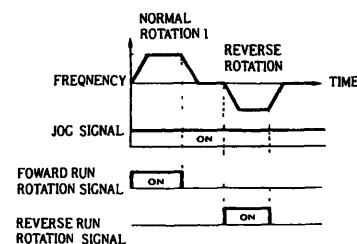

Analog input command control (gain/bias)

Item name	Parameter to be set	Factory Preset
Frequency command gain	bn-05	100%
Frequency command bias	bn-06	0%

Output frequency (gain/bias) can be set freely according to frequency setting (0 to 10V or 4 to 20mA).

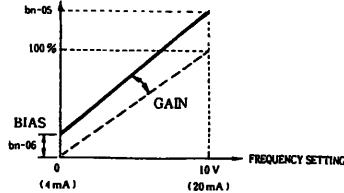

Full-range automatic torque boost

Item name	Parameter to be set	Factory Preset
Torque compensation gain	bn-07	1.0

Automatic control of V/f ratio according to the load torque ensures tripless operation and optimum output current. Normally, no adjustment is necessary. Use this function when especially high starting torque is required.

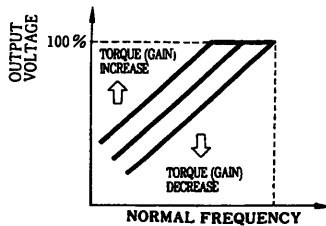

Frequency meter/Ammeter calibration

Item name	Parameter to be set	Factory Preset
Analog output gain	bn-11	1.00

Frequency meter/ammeter connected to the inverter can be calibrated without using a resistor for calibration.

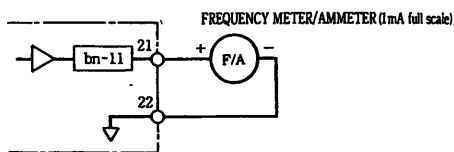

Slip compensation speed control

Item name	Parameter to be set	Factory Preset
Motor rated slip	bn-08	0.0%
Motor rated current	Cn-09	See page 52
Motor no-load current	Cn-34	30%
Slip compensation primary delay time	Cn-35	2.0s

Simple speed control (slip compensation) is available without motor speed detection (PG or TG). Frequency command from f_1 to f_2 eliminates speed fluctuations caused by varying loads.

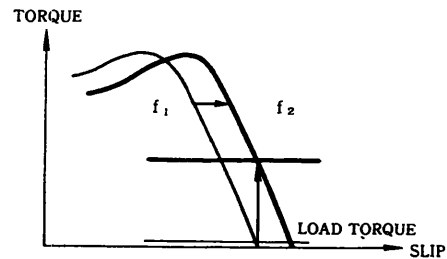

Multi-function input

Item name	Parameter to be set	Factory Preset
Multi-function input function	Sn-15 to 18	See page 50

Functions of external input terminals 5 to 8 can be switched. Set Sn-15 to Sn-18 in ascending order, or an OPE (parameter error) occurs. (ie. the lowest value programmed in must be set into the lowest number Sn constant)

Function of terminal 5 : set into Sn-15

Function of terminal 6 : set into Sn-16

Function of terminal 7 : set into Sn-17

Function of terminal 8 : set into Sn-18

Set value	Function	Set value	Function
00	Normal and reverse rotation selection	0A	Accel/decel prohibition
01	Operation signal selection	0B	Inverter overheat warning
02	Option/inverter switch	0C	Multi-function analog input enable
03	Multi-speed command 1 (master/aux change)*	D-F	Not used
04	Multi-speed command 2*	10	UP command
05	Multi-speed command 3	11	DOWN command
06	Jog frequency selection*	12	FJOG command
07	Accel/decel time setting	13	RJOG command
08	Coasting stop command for NO contact*	14 to 1F	Not used
09	Coasting stop command for NC contact	20 to 2F	External fault 1
		30 to 3F	External fault 2
		40 to 4F	External fault 3
		50 to 5F	External fault 4
		60	DC braking command (operation and jog take precedence)
		61	Search from max freq
		62	Search from set freq
		63	Energy saving operation

(* : Factory setting prior to shipment)

Accel/decel prohibition

Item name	Parameter to be set	Factory Preset
Accel/decel stop function	Sn-15 to 18	See page 51

Frequency can be set externally using a push button instead of speed pot. Set "OA" for any constant from Sn-15 to Sn-18.

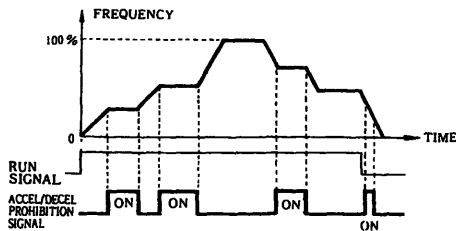

Note: Contact your YASKAWA representative for availability in North American markets

Inverter overheat warning

Item name	Parameter to be set	Factory Preset
Inverter overheat warning	Sn-15 to 18	See page 51

When terminal is closed, "OH2" blinks on the digital operator without stopping the inverter. (External thermal protection is required.) Set "0B" for any of Sn-15 to Sn-18.

UP/DOWN

Item name	Parameter to be set	Factory Preset
UP/DOWN	Sn-15 to 18	See page 51.

Allows remote speed setting with pushbutton. Set "10" or "11" in any constant from Sn-15 to 18.

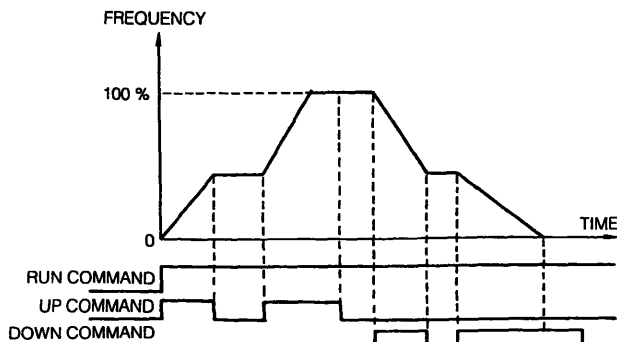

Speed search

Item name	Parameter to be set	Factory Preset
Speed search	Sn-15 to 18	See page 51.

Allows switch operation from commercial power to inverter. Set "61" or "62" into any constant from Sn-15 to Sn-18.

- 61: Search from max. frequency
- 62: Search from set frequency

Energy saving operation

Item name	Parameter to be set	Factory Preset
Energy saving level gain	bn-09	80%

If reduced output voltage is required after acceleration, the energy-saving function can be used to reduce it.

This function helps to eliminate motor/system vibration. Set "63" for any constant from Sn-15 to Sn-18.

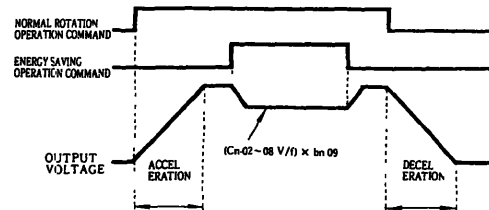

Multi-function output

Item name	Parameter to be set	Factory Preset
Multi-function contact output	Sn-20	See page 51.
Multi-function open collector output	Sn-21, 22	

Functions of external output terminals 9 to 10, 25 to 27, and 26 to 27 can be switched.

Function of terminals 9 and 10 : Set into Sn-20

Function of terminals 25 and 27 : Set into Sn-21

Function of terminals 26 and 27 : Set into Sn-22

Set value	Function	Set value	Function
00	In operation*	07	Low voltage detected
01	Zero speed*	08	Base blocked
02	Speed agreed*	09	Frequency command mode
03	Free speed agreed	0A	Operation command mode
04	Speed agreed detection (less than set value)	0B	Over torque detected
05	Speed agreed detection (more than set value)	0C	Frequency command missing
96	Inverter operation ready	0D	Braking resistor failure
		0E	Fault

(* : Factory setting prior to shipment)

Speed agreed signal output

Item name	Parameter to be set	Factory Preset
Desired frequency	Cn-21	0.0 Hz
Bandwidth	Cn-22	2.0 Hz
Multi-function contact output function	Sn-20 to 22	See page 51.

This function is used when operation at an arbitrary speed must be indicated. Set the multi-function contact output (Sn-20 to Sn-22) as follows:

[Example] Setting Sn-20=02 sets external output terminals 9 and 10 to indicate "speed agreed" (output frequency=input reference)

(1) Set value=2: "Speed agreed" detection

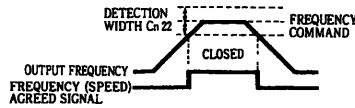

(2) Set value=3: "Medium speed" detection

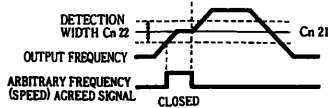

(3) Set value=4: "Below set point" detection

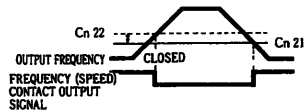

(4) Set value=5: "Above set point" detection

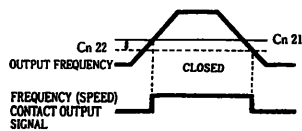

Multi-function analog input

Item name	Parameter to be set	Factory Preset
Multi-function analog input	Sn-19	0 0

An arbitrary function can be used with external input terminal 16.

Set Value	Function	Set Value	Function
00	Aux frequency ref	06	Accel/Decel time reduction coefficient
01	Frequency ref gain	07	DC injection current
02	Frequency bias 1	08	Stall level during run
03	Frequency bias 2	09	Frequency ref lower limit
04	Over torque detection level	0A	Prohibited set frequency
05	Voltage bias		

Functions for reduction of "Machine vibration and shock"

Following constants are effective for the reduction of machine vibration and shock.

	Effective Method	Constant	Factory Preset
Shock	• For the decrease of generated torque • For the increase of generated torque	Sn-02	01
		bn-07	1.0
		Cn-02 to 08	See page 52
	For the decrease of shock at accel.	Sn-06	× × 00
		bn-01, 03	10.0s
		Cn-28	170%
For the decrease of shock at decel.	Cn-29	50%	
	Sn-04	0011	
	Sn-06	0000	
	bn-02, 04	10.0s	
Vibration	For the decrease of carrier frequency	Cn-10	1.5Hz
		Cn-11	50%
	For the change of speed control characteristics	Cn-23, 24	15.0kHz
		Cn-25	0
		bn-08	0.0%
		Cn-34	30%
Cn-35	0.0s		
bn-09	80%		

TERMINALS AND STANDARD CONNECTION

For models CIMR-G3U2011 to -G3U2022
(200V class, 15 to 30HP, 11 to 22kW)

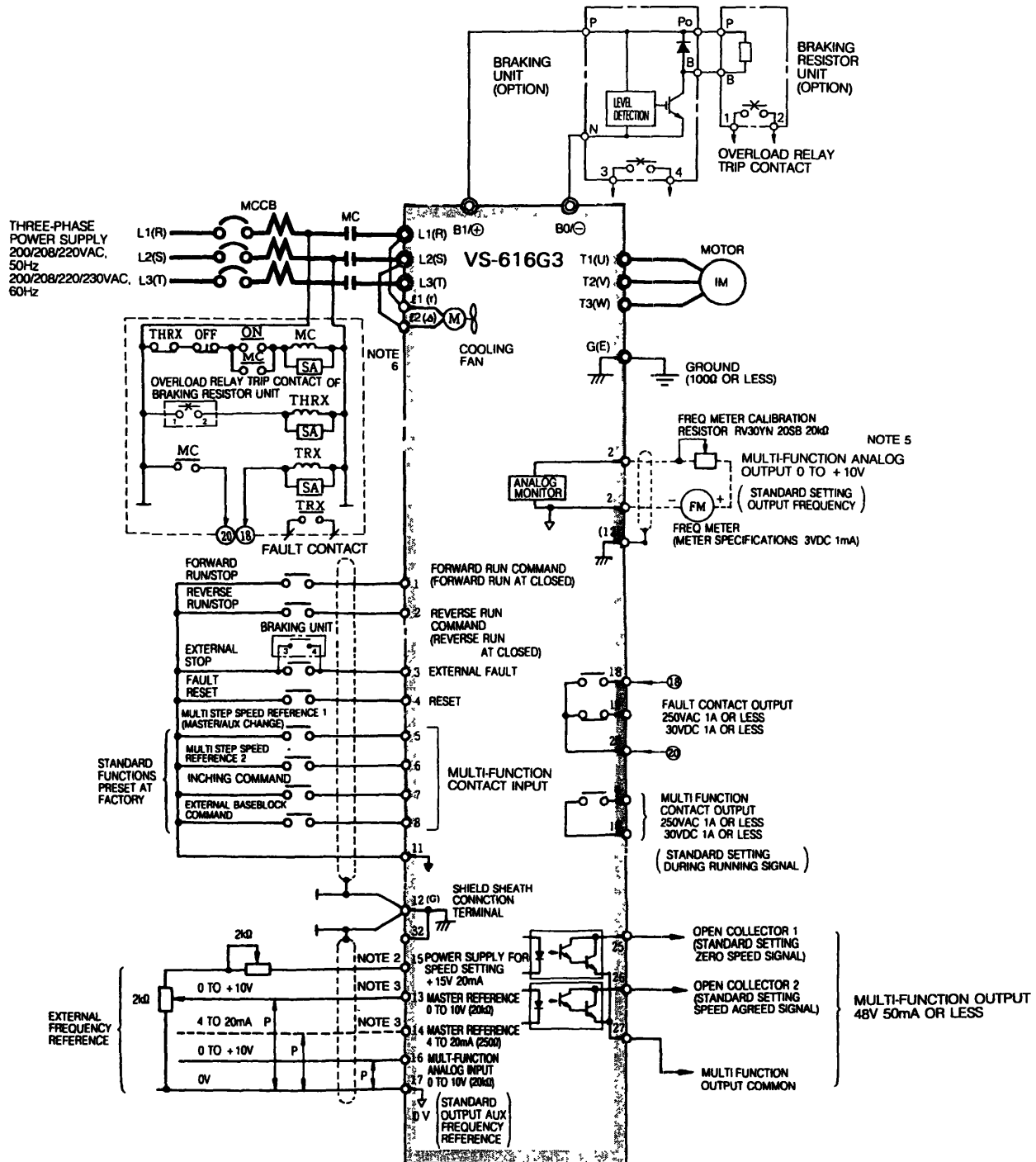

- Notes. 1. indicates shielded leads and twisted-pair shielded leads.
2. External terminal 15 of +15V has maximum output current capacity of 20mA.
3. Either external terminal 13 or 14 can be used.
4. Terminal symbols: shows main circuit; shows control circuit.
5. Multi-function analog output is for use on meters (frequency, current, voltage, watt) only, and not available for the feedback control system. Use analog monitor cards (Model AO - 08 or AO - 12) for control system feedback

MAIN CIRCUIT

Voltage		200 to 230V		
Model CIMR-G3		20P4 - 27P5	2011 - 2022	2030 - 2075
Max. applicable Motor Output		0.5 - 10HP (0.4 - 7.5kW)	15 - 30HP (11 - 22kW)	40 - 100 HP (30 - 75kW)
Terminal		Main circuit power unit		
L1 (R)		Inverter output		
L2 (S)				
L3 (T)				
T1 (U)				
T2 (V)				
T3 (W)				
B0 / ⊖		-	• Braking unit connector (B1/⊕ - B0/⊖)	-
B1 / ⊕		• Braking resistor unit connector (B1/⊕ - B2)	• DC bus (B1/⊕ - B0/⊖)*1	-
B2				-
⊖				• Braking unit connector (⊕1 - ⊖)
⊕3 (P3)				• DC bus (⊕1 - ⊖)*1
⊕1 (P1)				• Main circuit capacitor (⊕3-⊖)*2
I1 (r)			Cooling fan power input	• Control power input
I2 (s)				• Cooling fan power input
ℓ2 200 (200)				-
ℓ2 400 (400)				-
x				-
y				External power supply (220 VAC, 10VA)
G (E)		Grounding (ground resistance should be 100 ohms or less)		

*1 DC bus is not available for UL listed and CSA certified components.

*2 When using terminals ⊕3 (P3) - ⊖, contact your YASKAWA representative

Voltage		380 to 460V			
Model CIMR-G3		40P4 - 47P5	4011, 4015	4018 - 4045	4055 - 4300
Max. applicable Motor Output		0.5 - 10HP (0.4 - 7.5kW)	15HP (11kW), 20HP (15kW)	25 - 60HP (18.5 - 45kW)	75 - 400 HP (55 - 300kW)
Terminal		Main circuit power input			
L1 (R)		Inverter output			
L2 (S)					
L3 (T)					
T1 (U)					
T2 (V)					
T3 (W)					
B0 / ⊖				• Braking unit connector (B1/⊕ - B0/⊖)	-
B1 / ⊕		• Braking resistor unit connector (B1/⊕ - B2)	• Braking resistor unit connector (B1/⊕ - B2)	• DC bus (B1/⊕ - B0/⊖)*1	-
B2					• DC bus (B1/⊕ - ⊖)*1
⊖					• Braking unit connector (⊕1 - ⊖)
⊕3 (P3)					• DC bus (⊕1 - ⊖)*1
⊕1 (P1)					• Main circuit capacitor (⊕3-⊖)*2
I1 (r)			Cooling fan power input		• Control power input
I2 (s)					• Cooling fan power input
ℓ2 200 (200)					ℓ1 - ℓ2 200 · 200 to 230VAC
ℓ2 400 (400)					ℓ1 - ℓ2 400 · 380 to 460VAC
x					External power supply (220 VAC, 10VA)
y					-
G (E)		Grounding (ground resistance should be 100 ohms or less)			

*1 DC bus is not available for UL listed and CSA certified components.

*2 When using terminals ⊕3 (P3) - ⊖, contact your YASKAWA representative.

Voltage		500 to 600V		
Model CIMR-G3		51P5 - 57P5	5011 - 5022	5030 - 5160
Max. applicable Motor Output		2 - 10HP (1.5 - 7.5kW)	15 - 30HP (11 - 22kW)	40 - 200HP (30 - 160kW)
Terminal		Main circuit input power supply		
L1 (R)		Inverter output		
L2 (S)				
L3 (T)				
T1 (U)				
T2 (V)				
T3 (W)				
B0 / ⊖				• Braking resistor unit (B1/⊕ - B0/⊖)
B1 / ⊕		• Braking unit (B1/⊕ - ⊖)	• Braking resistor unit (B1/⊕ - B2)	-
B2				-
⊖				
I1 (r)			Cooling fan power supply (Control power input)	
I2 (s)				
ℓ2 200 (200)				
ℓ2 400 (400)				
x				External power supply (200 VAC 30VA)
y				
G (E)		Ground terminal		

CONTROL CIRCUIT (For 200V/400V/575V Class)

Classification	Terminal	Signal Function	Description	Signal Level	
Sequence Input Signal	1	Forward operation-stop signal	Forward run at closed, stop at open	Photo-coupler insulation Input +24VDC 8mA	
	2	Reverse operation-stop signal	Reverse run at closed, stop at open		
	3	External fault input	Fault at closed, normal state at open		
	4	Fault reset input	Reset at closed		
	5	Master/Aux change (Multi-step speed ref 1)	Aux. freq. ref at "closed"		Multifunction contact input the following signals available to select Forward/reverse select, run mode select, multispeed select, jog frequency select, accel/decel time select, external fault, external base block stop, hold command, inverter overheat prediction, DB command, aux input effective, speed search, energy-saving operation
	6	Multi-step speed ref.2	Effective at "closed"		
	7	Jog command	Jog run at "closed"		
	8	External coasting stop	Inv output stop at "closed"		
	11	Sequence control input common terminal	—		
Analog Input Signal	15	Power supply terminal for speed ref	Speed ref. power supply	+15V (Allowable current 20mA max)	
	13	Master speed frequency ref.	0 to +10V/100% freq	0 to +10V (20kΩ)	
	14		4 to 20mA/100% freq	4 to 20mA (250Ω)	
	16	Aux. frequency ref.	0 — 10V/100%	Multifunction contact input one of the following signals available to select, speed command, speed gain, speed bias, overtorque, overvoltage bias, rate of accel / decel, DB current	0 to +10V (20kΩ)
	17	Common terminal for control circuit	0		—
	12	Connection to shield sheath of signal lead	—	—	
Sequence Output Signal	9	During running (NO)	Run at "closed"	Multifunction contact output. one of the following signals available to output Output during running, zero speed, speed agreed, arbitrary speed agreed, frequency detection, overtorque, undervoltage, run mode, coasting stop, braking resistor overheat	Dry contact Contact capacity: 250VAC 1A or less 30VDC 1A or less
	10				
	25	Zero speed detection	Makes at min, freq. (Cn-07) or less		Open collector output +48V 50mA or less
	26	Speed agreed detection	Makes when the freq reaches to ±1Hz of set freq		
	27	Open collector output common			—
	18	Fault contact output (NO, NC)	Fault at closed between terminals 18 and 20 Fault at open between terminals 19 and 20		Dry contact Contact capacity: 250VAC 1A or less 30VDC 1A or less
	19				
20					
Analog Output Signal	21	Frequency meter output	0 to 10V/100% freq.	Ammeter/voltmeter/wattmeter output selection available	0 to 11V max. 2mA or less
	22	Common			

YOU CAN RELY ON THESE PROTECTIVE, V

Protection Function

Protection function		Explanation	Monitor display	Fault contact output
Low voltage protection	Main circuit low voltage	When the inverter power voltage drops, torque becomes insufficient and motor is overheated. Inverter output is stopped when the main circuit DC voltage becomes lower than the low voltage detection level for 15 ms or longer, or about 2 seconds or longer if the momentary power loss redo-thru function is used.	UV1 (UV1)	Operation
	Momentary power loss protection	Detection level: Approximately 210V or less for 200V class and 420V or less for 400V class		
	Control circuit low voltage	The inverter output is shut-off when the control circuit voltage drops below the low voltage level.	UV2 (UV2)	Operation
	Main circuit soft charge contactor defective	The inverter output is shut-off when no answer back is received from the main circuit soft-start contactor.	UV3 (UV3)	Operation
Overcurrent protection		The inverter output is shut-off when the inverter output current becomes approx. 200% and above of inverter rated current	OC (OC)	Operation
Ground-fault protection		The inverter output is shut-off when a ground-fault occurs at the inverter output side and the ground-fault current exceeds approximately 50% of the inverter rated current	GF (GF)	Operation
Overvoltage protection		The inverter output is shut-off when the main circuit DC voltage becomes excessive because of regeneration energy caused by motor deceleration and negative load. Detection. Approx. 800V for input voltage set 400V and above level. Approx. 700V for input voltage set 400V or less and approx. 400V for 200V class	OV (OV)	Operation
Fuse blown		The inverter output is shut-off when the main circuit transistor fails. The fuse clears to prevent wiring from being damaged by the short-circuit current	FU (FU)	Operation
Cooling fin overheat		The inverter output is shut-off when the ambient temperature rises and the heat sink fin reaches 90°C. Please check for a defective cooling fan or clogged filter.	OH (OH)	Operation
Overload protection	Motor	Inverter output is stopped when motor overload is detected by the electronic thermal overload in the inverter. Either a inverter duty constant-torque specialized motor or general-purpose motor can be selected. If more than one motor is driven, overload protection should be disabled. Use a thermal relay or thermal protector for each motor.	OL1 (OL1)	Operation
	Inverter	The inverter output is shut-off when the electronic thermal overload reaches or exceeds the inverse time limit of 112% of the inverter's rated current occurs. Maximum rated overload: 150%, 1 min.	OL2 (OL2)	Operation
	Over torque detection	The motor operates according to a preset mode when the inverter output current exceeds the overtorque detection level. This function is used to protect the machine or to monitor the output torque.	OL3 (OL3)	Operation
Braking transistor fault		Inverter output is shut off when an error occurs in the braking transistor	rr (rr)	Operation
Braking resistor overheat		For 5HP (3.7kW) or less (200V), 3HP (2.2kW) or less (400V), an optional dedicated resistor can be installed. The resistor is monitored by the electronic thermal switch for overheating. The inverter output is shut-off when a specified temperature is reached.	rH (rH)	Operation
Cooling fan fault		When a cooling fan comes to fault, the inverter operates according to a preset stop method (coasting to a stop, ramp to stop, or continuous operation). For 40Hp (30kW) or more (200V), 75HP (55kW) or more (400V).	FAn (FAN)	Operation
External fault signal input		When an external alarm signal is input, the inverter operates according to a preset stop method (coasting to a stop, continuous operation, or ramp to stop)	EF[] EF3 to EF8	Operation
Control circuit fault, Communication option fault, Option fault, Parameter set error		The inverter output is shut-off when a transmission error occurs in the control circuit or a component fails. The inverter output is also shut-off when a specialized option such as the digital operator is not properly connected.	CPF00 CPF05 CPF06 CPF23 Err	Operation
Communication error		When any communication error between communication interface card (SI-B, option) and master controller occurs, the inverter operates according to a preset stop method (coasting to a stop, ramp to stop, or continuous operation).	bUS (BUS)	Operation

ARNING, AND SELF-DIAGNOSIS FUNCTIONS

	Error causes	Action to be taken
	<ul style="list-style-type: none"> • Inverter capacity is too small. • Voltage drop due to wiring • Inverter power voltage selection is wrong. • A motor of large capacity (11 kW or greater) connected to the same power system has been started • Rapid acceleration with generator power supply • Operation sequence when power is off • Defective electromagnetic contactor 	<ul style="list-style-type: none"> • Check the power capacity and power system. • UV display appears when the inverter power is turned off while operation signal is input Remove the power after stopping the inverter. (Set the third and fourth bits of Sn-04 to 01)
	<ul style="list-style-type: none"> • Extremely rapid accel/decel • Motor on/off switching at the inverter output side • Short-circuit or ground-fault at the inverter output side • Motor of a capacity greater than the inverter rating has been started. • High-speed motor or pulse motor has been started. 	Transistor error may occur Investigate the error cause, correct it, then restart
	<ul style="list-style-type: none"> • Motor dielectric strength is insufficient. • Load wiring is not proper. 	Check for ground-fault in motor or load wiring.
	<ul style="list-style-type: none"> • Over voltage • Insufficient deceleration time • Regenerative load (Motor is turned by the load.) • High input voltage compared to motor rated voltage 	If braking torque is not proper, extend the decel time or use a braking resistor (If braking resistor is already installed, verify that Sn-10, 2nd digit to 1.)
	<ul style="list-style-type: none"> • Repeated overcurrent protection (OC) • Repeated overload protection (OL2) power reset • Rapid deceleration in excess excitation (improper V/f characteristic setting) • External noise 	Correct the cause, check the main circuit transistor, replace the fuse, then restart.
	<ul style="list-style-type: none"> • Defective cooling fan • Ambient temperature rise • Clogged filter 	Replace the cooling fan and clean the filter. Ambient temperature: 104°F (40°C) or less for enclosed type 122°F (50°C) or less for open chassis
	<ul style="list-style-type: none"> • Overload, low speed operation or extended acceleration time, improper V/f characteristic setting • Wrong setting of motor rated current (Cn-09) 	<ul style="list-style-type: none"> • Investigate the cause of overload and review the operation pattern, V/f characteristic, and motor/inverter capacities (If inverter is repeatedly reset after an overload occurs, the inverter may fault. Investigate and correct the cause of overload.) • Set rated current (of motor nameplate) in Cn-09.
	Motor current exceeds the preset value because of machine error or overload.	Check the use of the machine. Correct the overload cause or set a higher detection level which is within the allowable range.
	<ul style="list-style-type: none"> • Insufficient resistance of braking resistor • Short-circuit or ground-fault in braking resistor 	Review the resistance of the braking resistor and braking duty cycle. Change the resistance or increase the inverter capacity.
	<ul style="list-style-type: none"> • Frequent operation stop • Long-time continuous regeneration • Rapid deceleration 	Shorten deceleration time or review the braking torque brake duty cycle (%ED) Use optional braking resistor or braking unit.
	Defective cooling fan	Replace the cooling fan
	External fault condition occurred.	Correct the cause of the fault input See Un-07 for the state of input signal.
	<ul style="list-style-type: none"> • External noise • Excess vibration or shock 	<ul style="list-style-type: none"> • Check data in Sn-01 and Sn-02. Record all data, then use Sn-03 for initializing. • Turn off power, then turn on again. If error is persistent, contact your YASKAWA representative.
	<ul style="list-style-type: none"> • External noise • Excessive vibration or shock • Poor connection 	<ul style="list-style-type: none"> • Check data in Sn-01 and Sn-02 Record all data, then use Sn-03 for initializing • Turn off power, then turn on again If error is persistent, contact your YASKAWA representative • Check for communication cable between communication interface card (SI-B) and master controller.

Warning and Self-Diagnosis Functions

Protection function		Explanation	Monitor display	Fault contact output
Low-voltage protection (main circuit voltage insufficient)		Monitor display appears if low voltage protection conditions such as a drop in main circuit voltage or momentary power loss occur while the inverter output is off.	(UV) UU (Blink)	Non operation
High voltage protection		Monitor display appears when the main circuit DC voltage rises above the detection level while the inverter output is off.	(OV) OU (Blink)	Non operation
Cooling fin overheat warning		Monitor display appears when a separate thermal protector contact is input to the external terminal.	(OH2) oH2 (Blink)	Operation
Overtorque detection		This function is used to protect the machine and to monitor the inverter output torque. The inverter output reacts in a preset manner when the inverter output current exceeds the over torque detection level. The monitor display blinks when "operation continue" is preset.	(OL3) oL3 (Blink)	Non operation
Stall prevention (Accel/decel is accomplished with maximum capacity of the inverter without tripping on over-current or overvoltage.)	During acceleration	Inverter acceleration is stopped when 170% of or more of the inverter rated current is required by the load. This prevents overload protection (OL1, OL2) or overcurrent (OC) from occurring. When current is reduced to less than 170%, acceleration is enabled.	—	Non operation
	During normal operation	Output frequency is decreased when 160% of the inverter rated current or greater is required by the load. This prevents motor and inverter overload (OL1, OL2). When current is reduced below 160%, inverter acceleration is then enabled.		
	During deceleration	Deceleration is stopped when the DC voltage is caused to rise by motor regenerative energy. This prevents overvoltage trips (OV). When DC voltage decreases, deceleration to the set value then resumes.		
Cooling Fan Fault		At cooling fan fault, when setting a preset stop method of the inverter to "continuous operation," a monitor display blinks. (Effective only for 200V class 40HP (30kW) or more, 400V class 75HP (55kW) or more, or 575V class 30HP (22kW) or more)	(FAN) FAn (Blink)	Non operation
Simultaneous normal and reverse rotation commands		When forward and reverse rotation commands are simultaneously detected for a period of time exceeding 50 ms, the inverter is stopped according to the preset stop method.	(EF) EF (Blink)	Non operation
External fault signal input (Minor failure)		It is indicated on the monitor when the mode after external signal input is set to "Operation continue."	EF (Blink) EF3 to EF8	Non operation
External base block signal input (main circuit transistor instantaneous shut-off)		When an external base block signal is input, the motor coasts to a stop. When the external base block signal is removed, the inverter output is immediately turned on at the previously set frequency.	(BB) bb (Blink)	Non operation
Invalid parameter setting		When an invalid parameter is set, it is indicated on the monitor at power up or when the inverter is changed from the PRGM mode to the DRIVE mode.	oPE0 oPE1	Non operation
Communication error		When any communication error between communication interface card (SI-B, option) and master controller (PLC) occurs and a preset stop method of the inverter is set to "continuous operation," a monitor display blinks.	(BUS) bUS (Blink)	Non operation
Communication ready		When the inverter with communication interface card (SI-B, option) does not receive correct data from master controller (PLC), "CALL" is displayed.	CALL (CALL)	Non operation

	Error causes	Action to be taken
	<ul style="list-style-type: none"> • Input voltage drop 	Check the main circuit DC voltage in Un-xx. If the voltage is low, adjust the input voltage.
	<ul style="list-style-type: none"> • Input voltage rise 	Check the main circuit DC voltage in Un-xx. If the voltage is high, adjust the input voltage.
	<ul style="list-style-type: none"> • Overload • Cooling fan fault • Ambient temperature rise • Clogged filter 	Replace the cooling fan and clean the filter Ambient temperature: 104°F (40°C) or less for enclosed type 122°F (50°C) or less for open chassis.
	<ul style="list-style-type: none"> • Motor current exceeded the set value because of machine fault or overload 	Check the driven machine and correct the cause of the fault or set to a higher value.
	<ul style="list-style-type: none"> • Insufficient power for accel/decel • Overload • Phase loss 	<ul style="list-style-type: none"> • Set proper accel/decel time for smooth operation • For stall prevention during normal operation lighten the load or increase inverter capacity.
	Defective cooling fan	Replace the cooling fan.
	<ul style="list-style-type: none"> • Operation sequence error • 3-wire/2-wire selection error 	<ul style="list-style-type: none"> • Recheck the control sequence. • Recheck system constant (Sn-15 to -18).
	<ul style="list-style-type: none"> • External fault conditions set-up 	Take appropriate measurement for the cause of external fault input
	_____	_____
	<ul style="list-style-type: none"> • Invalid parameter setting 	<ul style="list-style-type: none"> • Review the parameter setting range and conditions.
	<ul style="list-style-type: none"> • External noise • Excessive vibration or shock • Poor connection 	<ul style="list-style-type: none"> • Check data in Sn-01 and Sn-02. Record all data, then use Sn-03 for initializing. • Turn off power, then turn on again. If error is persistent, contact your YASKAWA representative. • Check for communication cable between communication interface card (SI-B) and master controller.
	<ul style="list-style-type: none"> • Poor connection • Defective communication software (PLC) 	<ul style="list-style-type: none"> • Check for communication cable between communication interface card (SI-B) and master controller (PLC). • Check for communication software.

NOTES ON USE OF INVERTER

Selection

- When the inverter is connected directly to a large-capacity power transformer (1000kVA or greater with 10 m or less cable length) or when a phase advance capacitor is switched, excess peak current may occur in the power feed circuit and the converter section may be damaged. To avoid this, use an AC reactor (option) on the inverter input side. An AC reactor is also required when a thyristor converter such as a DC drive is connected to the same power system.
- When a special motor is used or more than one motor is driven in parallel with a single inverter, select the inverter capacity so that 1.1 times of the total motor rated current does not exceed the inverter rated output current.
- The motor starting and accelerating characteristics of the motor driven by an inverter are restricted by the overload current ratings of the inverter. Compared to running with commercial power supply, lower torque output should be expected. If high starting torque is required, use an inverter of higher capacity or increase the capacities of both the motor and the inverter.
- When an error occurs, a protective circuit is activated and the inverter output is turned off. However, the motor cannot be stopped immediately. Use a mechanical brake and hold the equipment for an emergency stop if necessary.
- Terminals B1/⊕, B0/⊖, B2, ⊖, ⊕ 1 and ⊕ 3 are for Yaskawa options. Do not connect other equipment.

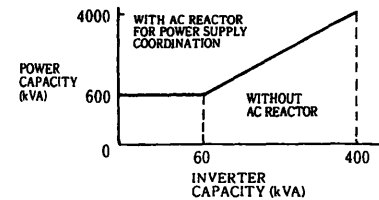

Installation

- Avoid oil mist or dust. Place the inverter in a clean area or house it in a totally enclosed case so that no contamination enters. To use the totally enclosed case, select the cooling method and panel dimensions so the inverter ambient temperature will be within the allowable range.
- Do not install the inverter on flammable material, such as wood.
- Install the inverter on a wall with the longer side in the vertical position.

Setting

- The inverter can be driven at an output frequency of up to 400 Hz with the digital operator. Setting errors may create a dangerous situation. Set the upper limit with the upper limit frequency setting function. (Maximum output frequency in external input signal operation is preset to 60 Hz at the factory.)
- Large DC injection braking operating voltages and times may cause motor overheating.
- Motor accel/decel time is determined by the motor generating torque, load torque, and load inertia WK^2 (GD^2). If the stall prevention function is activated during accel/decel, set the accel/decel time longer. After the stall prevention function is activated, the accel/decel time is extended to a length that the inverter can handle. To shorten the accel/decel time, increase the capacity of the inverter and possibly the motor.

Operation

- Applying power to inverter output terminals T₁ (U), T₂ (V), or T₃ (W) will damage the inverter. Double check wiring and sequence before turning the power on.
- If magnetic contactor (MC) is used on the primary side of the inverter, do not use the MC for starting and stopping the inverter. Otherwise, the inverter life may be reduced.
- After turning power to the inverter off, electric charges in the internal capacitors are retained temporarily. Wait until the charge lamp goes off before touching the inside of the inverter.
- Use round pressure terminals for wiring of UL listed and CSA certified inverters. Perform caulk securely by using caulking tool specified by terminal maker.

NOTES ON USE OF PERIPHERAL UNITS

■ Installation and selection of molded-case circuit breaker

On the input power side, a molded case circuit breaker (MCCB) to protect inverter primary wiring should be installed. The inverter power-factor (depending on power voltage, output frequency, and load) must be taken into account for selecting MCCB. For standard settings, see page 78. If a full electromagnetic MCCB is to be used, select a larger capacity because the operating characteristics are altered by harmonic current. A leakage current breaker of inverter use is recommended.

■ Use of input side magnetic contactor

The inverter can be used without an input side magnetic contactor (MC). An input MC can be used to prevent an automatic restart after recovery from an external power loss during remote control operation. However, do not use the MC frequently for start/stop operation, or it will lead to a reduced reliability. When the digital operator is used, automatic restart after power failure is disabled so that MC starting is impossible. Although primary the MC can stop the inverter, regeneration braking is disabled and the motor coasts to stop.

■ Use of secondary magnetic contactor

In general magnetic contactors on the output of the inverter, for motor control should not be used. Starting a motor with the inverter running will cause large surge currents and the inverter overcurrent protector to trigger. If an MC is used for switching to commercial power supply, switch MC after the inverter and the motor stop. To switch during motor rotation, use the speed search function. (See page 60.)

■ Use of overload relay

The inverter includes an electronics thermal protective function to protect the motor from overheating. If more than one motor is driven with a single inverter or when a multi-pole motor is used, place a overload relay between the inverter and the motor. Set 1 to the first position of Sn-14 (xxx1), and set the overload relay to the current nameplate value at 50 Hz, or 1.1 times of that at 60 Hz.

■ Power-factor improvement (elimination of phase advance capacitor)

To improve the power-factor, install an AC reactor on the inverter's primary side. Power-factor improvement capacitor or surge suppressors on the inverter output side will be damaged by the harmonic component in the inverter output. Also, the overcurrent caused in the inverter output will trigger the overcurrent protection. To avoid this, do not use capacitors or surge suppressors in the inverter's output. To improve the power-factor, install an AC reactor on the inverter primary side.

■ Radio frequency interference

Because the inverter I/O (main circuit) contains a higher harmonics component, it may emit RFI noise to communication equipment (AM radio, etc.) near the inverter. Use a noise filter to decrease the noise. Use of a metallic conduit between the inverter and motor and grounding the conduit is also effective. Proper routing of input and output leads is also recommended.

■ Wire thickness and cable length

If the inverter is connected to a distant motor, (especially when low frequency is output,) motor torque decreases because of voltage drop in the cable. Use sufficiently heavy wire.

When a digital operator is to be installed separately from the inverter, use the Yaskawa connection cable (option). For remote control with analog signals, connect the operating pot or operating signal terminal and the inverter within 50 m of the inverter. The cable must be routed separately from power circuits (main circuit and relay sequence circuit) so that it is not subjected to inductive interference by other equipment. If frequencies are set not only from the digital operator but also with external frequency controller, use twisted pair shielded wire as shown in the following figure and connect the shielding to terminal 12, not to the ground.

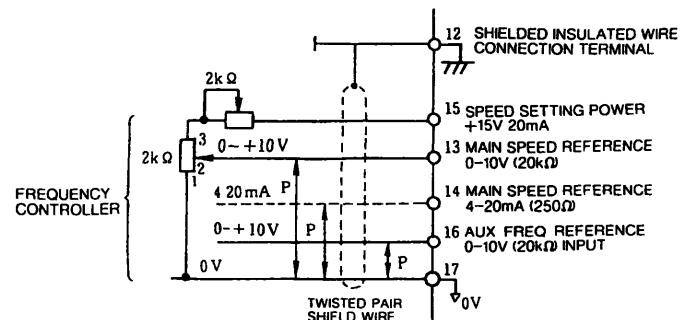

OPTION UNITS

Type	Name	Model (Code No.)	Function	Installation	Page	Manual No.	
Speed (Frequency) Reference Option Card	Analog reference card	AI-14U (73600-C001X)	Allows high precision, high resolution analog speed reference setting • Input signal level 0 to +10VDC (20k Ω) 1 channel 4 to 20mADC (250 Ω) 1 channel • Input resolution 14 bits (1/16384)	Built-in	76	TOE-C736-30 13	
	Analog reference card	AI-14B (73600-C002X)	Allows bipolar high precision, high resolution analog speed ref set • Input signal level 0 to \pm 10VDC (20k Ω) 4 to 20mADC (250 Ω) 3 channels • Input resolution 13 bits -code (1/8192)		76	TOE-C736-30 14	
	Digital reference card	DI-08 (73600-C003X)	Allows 8 bits digital speed ref set • Input signal binary 8 bits/BCD 2 digits + code • Input voltage +24V (isolated) • Input current 8mA } Built-in power supply		76	TOE-C736-30 15	
	Digital reference card*	DI-16G (73600-C011X)	Permits setting 16-bit digital speed reference • Input signal Binary 16 bits/BCD 4 digits + code • Input voltage +24V (isolated) • Input current 8 mA } External supply With 16-bit/12-bit select function		77	TOE-C736-30 17	
Control power unit for DI-16G		AVR387 (72600-AVR387) AVR388 (72600-AVR388)	Used to supply power to digital reference card (DI-16G) • Input 200 to 240VAC \pm 10% 50/60Hz • Output +24VDC 0.2A For momentary power loss, use AVR388 (holding time 2 sec available)	Separately installed	77		
Communication interface card		SI-B (73600-C006X-□□)	Permits operation or constant setting by command from master controller • Communication method Synchronous • Communication speed 19.2kBPS (up to 136.5kBPS possible) • Interface RS-232, RS-422, RS-485		77	-	
Feedback Speed Control Card	PG speed control card (Note)	PG-C (73600-D005X)	Permits compensation of speed variation caused by slip, by speed feedback using a pulse generator (PG) provided to the motor • Adaptation to single end or open collector input • Phase A (single phase) input • PG frequency range 50 to 32767Hz • Pulse monitor output +12V, 20mA • Input Voltage +12V • Input current 300mA } External supply	Built-in	77	TOE-C736-30 3	
		PG-D (73600-D006X)					• Adaption to differential input • Phase A (differential pulse) input • PG frequency range 50 to 32767Hz • I/O complies with RS-422A
Control power unit for PG-C		AVR385 (72600-AVR385) AVR386 (72600-AVR386)	Used to supply power to PG speed control card (PG-C) • Input 200 to 240VAC \pm 10% 50/60Hz • Output +24VDC 0.3A For momentary power loss, use AVR386 (holding time 2 sec available)	Separately installed	77		
Monitor Option Card	Analog monitor card	AO-08 (73600-D001X)	Outputs analog signal for monitoring inverter output state (output freq, output current etc) after absolute value conversion • Output resolution : 8 bits (1/256) • Output voltage 0 to +10V (non isolated) • Output channel 2 channels	Built-in	76	TOE-C736-30 21	
	Analog monitor card	AO-12 (73600-D002X)	Outputs analog signal for monitoring inverter output state (output freq, output current etc) • Output resolution 11 bits (1/2048) • Output voltage -10 to +10V (non isolated) • Output channel 2 channels		76	TOE-C736-30 22	
	Pulse output card	PO-36F (73600-D003X)	Outputs pulse train signal corresponding to the inverter output frequency • Output pulse 1F, 6F, 10F, 12F, 36F (F output freq) • Output voltage +12V \pm 10% (isolated) • Output current 20mA max		76	TOE-C736-30 23	
	Digital output card	DO-08 (73600-D004X)	Outputs isolated type digital signal for monitoring inverter run state (alarm signal, zero speed detection etc) Output channel Photo coupler 6 channels (48V, 50mA or less) Relay contact output 2 channels (250VAC, 1A or less) (30VDC, 1A or less)		77	TOE-C736-30 24	
Option Unit	Digital monitor	JVOP-101 (73041-0911X)	Allows freq or current digital monitor displays and fault indications Run/stop operation and constant settings are protected against tampering on site	Inverter-mounted	75	TOE-C730-50 4	
	Adapter panel for digital operator/digital monitor	JVOP-109 (73041-09190)	Adapter panel is capable of mounting on the front of inverter unit with its special cable. Use the adapter panel special cable.		75		
	Adapter panel special cable	1m-cable (72616-W3001-01) 3m-cable (72616-W3003-01)	Used for the remote operation of digital operator or monitor with adapter panel (JVOP-109) Cable length ; 1m, 3m		75	TOE-C736-50 11	
	Special cable for digital operator/ digital monitor (with blank cover)	1m-cable (72616-W3001) 3m-cable (72616-W3003)	Used for the operation of digital operator or monitor when removed from the front of inverter unit Cable length , 1m, 3m		75	TOE-C730-50 10	
	Remote interface	JVOP-104 (73041-0914X)	Incorporated with inverter when RUN/STOP or monitoring from remote locations (max 100m) by using remote operator (type JVOP-102) and remote monitor (type JVOP-103) 20mA current loop/RS-232C (D-SUB connector and cover provided)		75		
	Remote operator	JVOP-102 (73041-0912X)	The operation panel incorporates digital operator (type JVOP-100) and digital monitor (type JVOP-101) Permits RUN/STOP operation or monitor from remote locations (max 100 m) through serial communication 20 mA current loop Power supply 85 to 264VAC 50 to 60Hz (D-SUB connector, cover and power supply connector provided)		Separately installed	75	TOE-C736-20 4
	Remote monitor	JVOP-103 (73041-0913X)					

*When using these cards, contact your YASKAWA representative

Type	Name	Model (Code No.)	Function	Installation	Page	Manual No.
Option Unit	Copy unit	JVOP-105 (73041-0915X)	Copy unit is capable of reading constants from an inverter, storing the constants, and then writing the constants to other inverters. In addition, it has the same function as standard digital operator JVOP-100	Inverter-mounted	71	TOE-C736-50 7
	VS operator (small plastic type)	JVOP-95*□ (73041-0905X-□)	Allows frequency settings and RUN/STOP operations with analog ref from remote locations (max 50m) Frequency meter specifications 60/120Hz, 90/180Hz	Separately mounted	75	—
	VS operator (standard steel plate type)	JVOP-96*□ (73041-0906X-□)	Allows frequency settings and RUN/STOP operations with analog ref from remote locations (max 50m) Frequency meter specifications 75Hz, 150Hz, 220Hz		75	—
	Braking unit	CDBR-□ (72600-R□□□0)	For motor decel time reduction, use this with braking resistor unit		78 to 80	TOE-C736-50 5
	Braking resistor unit	LKEB-□ (72600-K□□□0)	Motor regenerative energy dissipation by the resistor reduces the decel time (duty cycle 10% ED)	Inverter-mounted	78 to 80	—
	Braking resistor (built-in type)	ERF-150WJ□□ (R00□□□□)	Motor regenerative energy dissipation by the resistor reduces the decel time (duty cycle 3% ED)		78 to 80	—
	Backup capacitor for momentary power loss	P00□0 (73600-P00□)	For power loss of less than 2 sec	Separately mounted	80	TOE-C736-50 6
	Rubber bushing	(FL6402826-1)	Used when installing inverter in totally-enclosed control panel	Inverter-mounted	43	—

PERIPHERAL UNITS

Name	Model (Code No.)	Function	Page
VS System Module	JGSM-□	Precise and complex drive system control Available in 15 types	86
Frequency Meter	DCF-6A	Provided with VS operator as standard Available as separate components for remote control from several locations	86
Frequency Setting Frequency Meter Adjusting Potentiometer Frequency Setting Knob	—		
Potentiometer	—		
AC Reactor	UZBA-□	<ul style="list-style-type: none"> • Motor noise reduction • Starting torque improvement • For motors exceeding the inverter capacity 	83 to 85
Radio noise Protective Filter	LNFD, HF, LF	Used the radio noise filter to eliminate radio wave interference It is provided at input terminals of the inverter main circuit.	88 to 91
Molded-case Circuit Breaker (MCCB)	NF□	Installation of MCCB at power supply will protect the inverter connection.	82
Magnetic Contactor (MC)	HI-□E	MC is required on inverters using the dynamic braking function	82
Surge Suppressor	DCR2-□	Suppresses surge currents by opening and closing of magnetic contactors and control relays. Must be installed on magnetic contactors or control relays near the inverter	82
Output Voltmeter	SCF-12NH	Voltmeter for PWM inverter	86
Potential Transformer	UPN-15B	Combined with output voltmeter (SCN-12NH) of 400V class inverter	86
Isolator	DGP□	Isolates the inverter's input and output signals to reduce noise	87

OPTION UNITS, OPTION CARDS

STANDARD STEEL PLATE TYPE

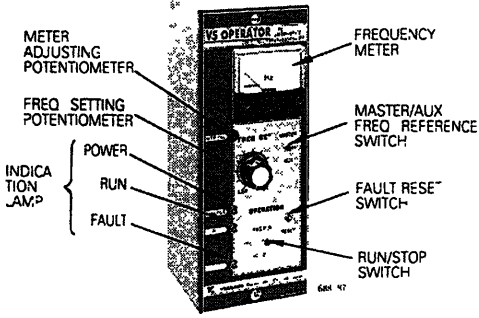

• PRODUCT SERIES

Model JVOP	Code No. 73041-0906X-1	Frequency Meter Specifications	
-96 • 1	-01	Model	75Hz
-96 • 2	-02	DCF-6A,	150Hz
-96 • 3	-03	3V, 1mA	220Hz

• DIMENSIONS in inch (mm)

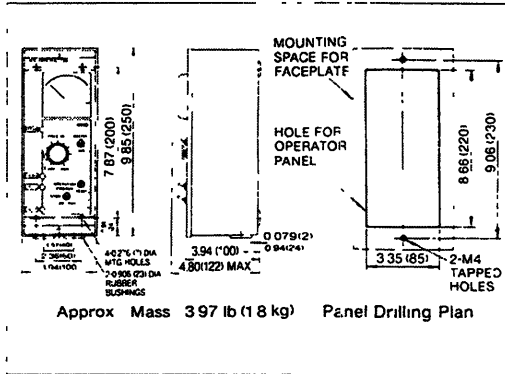

DIGITAL OPERATOR JVOP-100

DIGITAL MONITOR MODEL JVOP-101

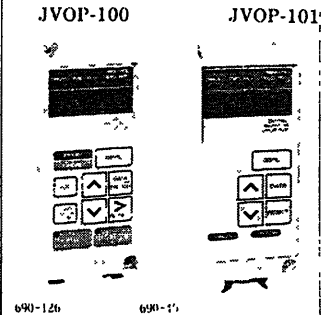

Mass: 0.22 lb (0.1 kg)

SMALL PLASTIC TYPE

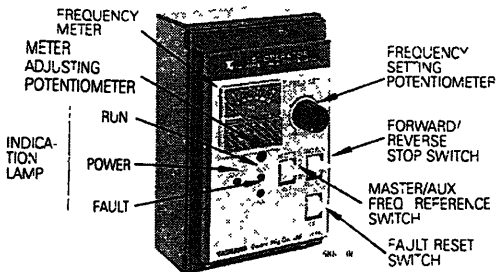

• PRODUCT SERIES

Model JVOP	Code No. 73041-0905X-1	Frequency Meter Specifications	
-95 • 1	-01	Model TRM-45	60/120Hz
-95 • 2	-02	3V, 1mA	90/180Hz

• DIMENSIONS in inch (mm)

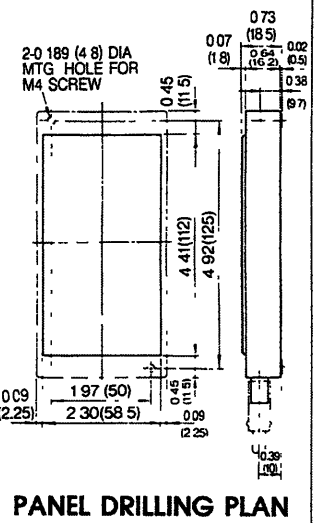
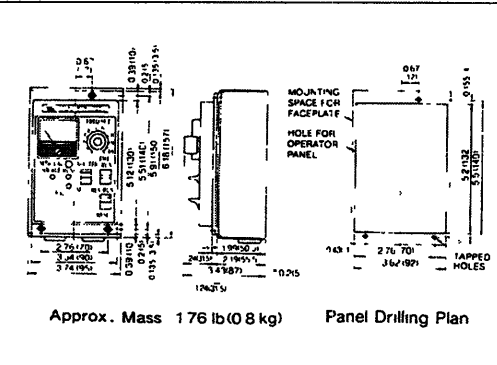

DIGITAL OPERATOR/ ADAPTER PANEL FOR DIGITAL MONITOR

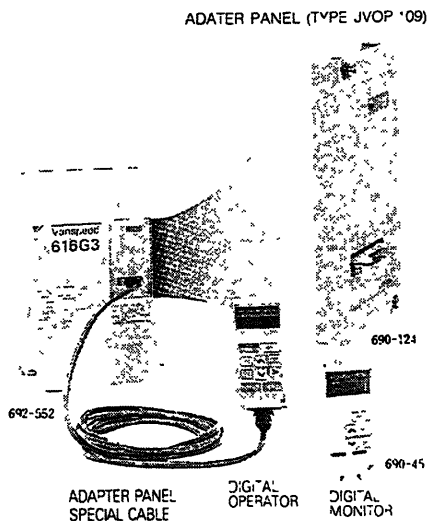

DIGITAL OPERATOR/ SPECIAL CABLE FOR DIGITAL MONITOR

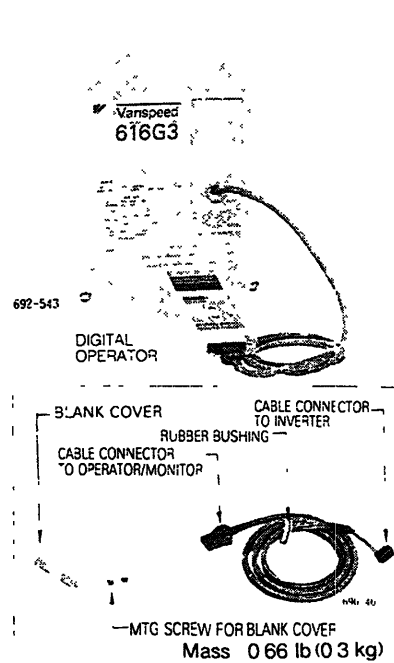

REMOTE OPERATOR/ REMOTE MONITOR REMOTE INTERFACE

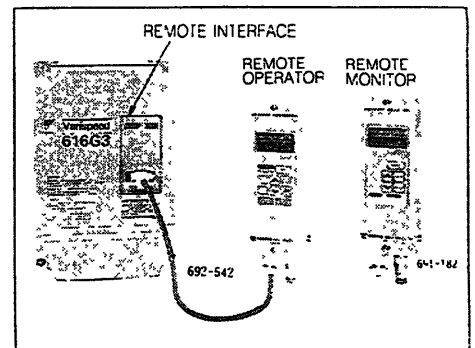

COPY UNIT

Model JVOP-105

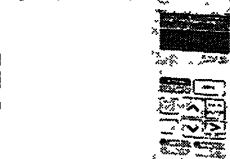

INPUT (2CN)

**ANALOG REFERENCE CARD
AI-14U
Unidirectional-type**

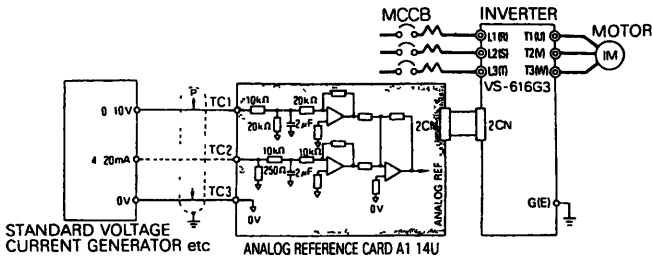



STANDARD VOLTAGE
CURRENT GENERATOR etc

ANALOG REFERENCE CARD AI-14U

OUTPUT (3CN)

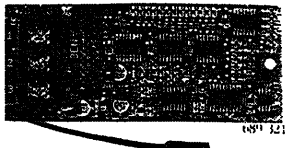
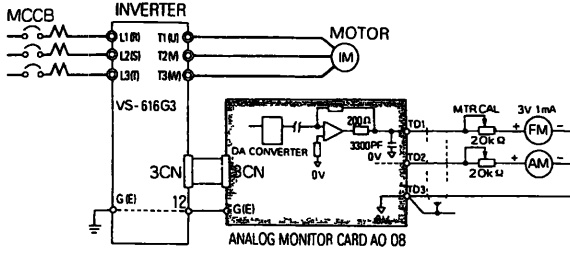
**ANALOG MONITOR CARD
AO-08**

ANALOG MONITOR CARD AO-08

**ANALOG REFERENCE CARD
AI-14B
Bidirectional-type**

STANDARD VOLTAGE
CURRENT GENERATOR etc

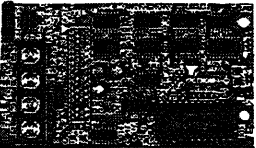
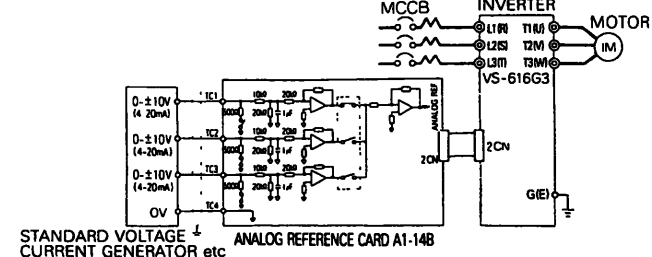
ANALOG REFERENCE CARD AI-14B

**ANALOG MONITOR CARD
AO-12**

ANALOG MONITOR CARD AO-12

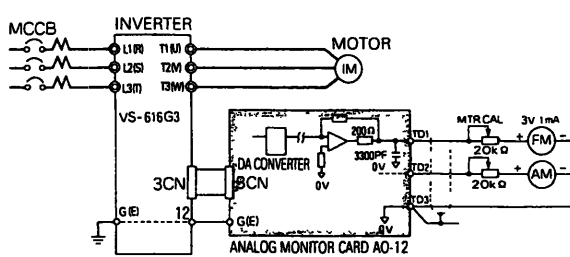
**DIGITAL REFERENCE CARD
DI-08**

TRANSISTOR
OPEN COLLECTOR
OR SWITCH

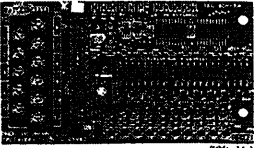
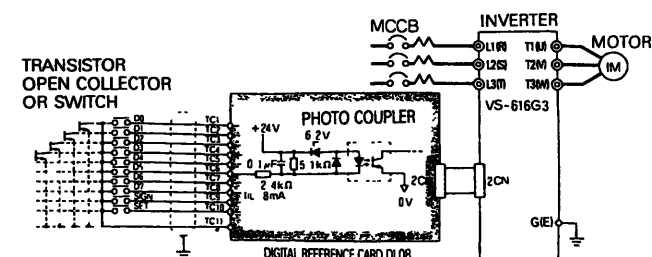
PHOTO COUPLER

DIGITAL REFERENCE CARD DI-08

**PULSE MONITOR CARD
PO-36F**

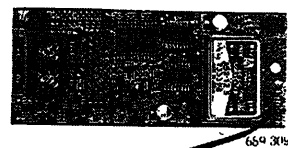
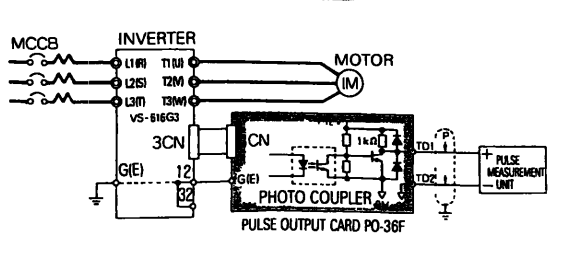
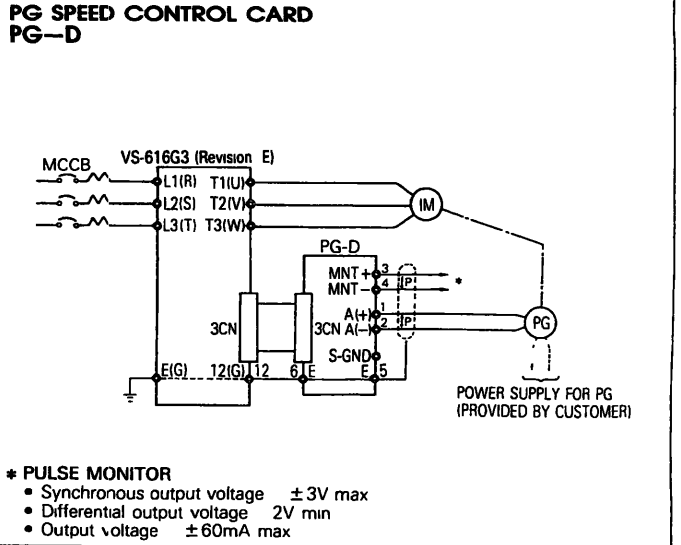
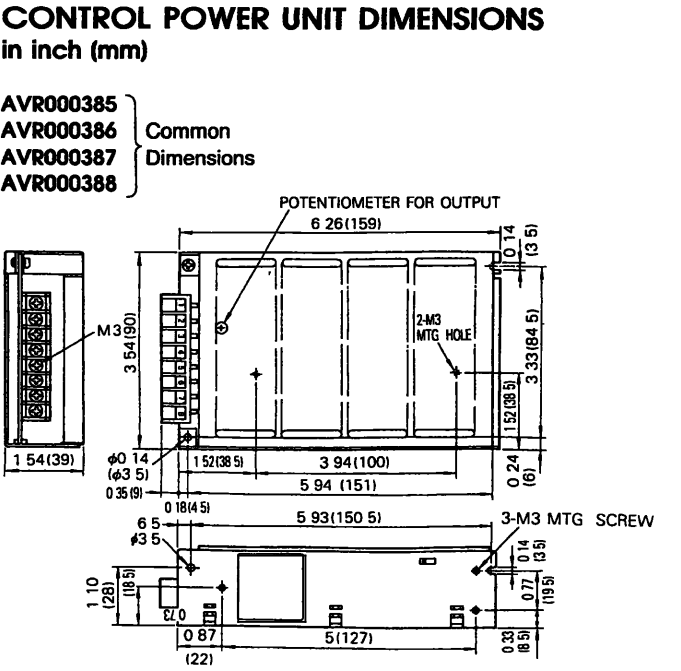
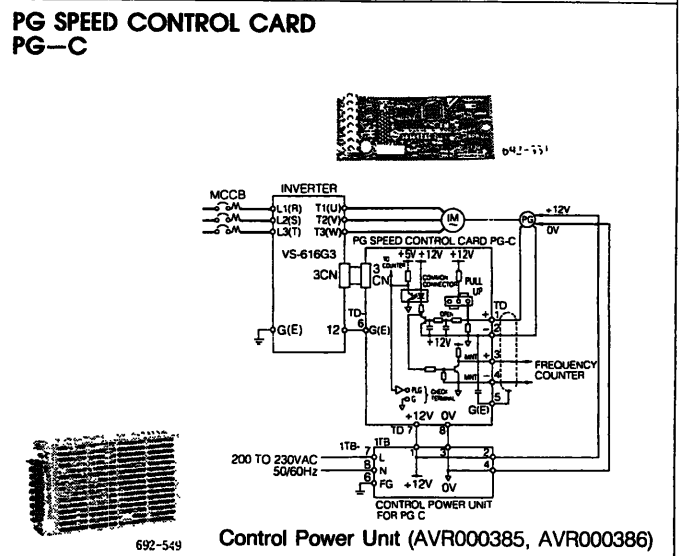
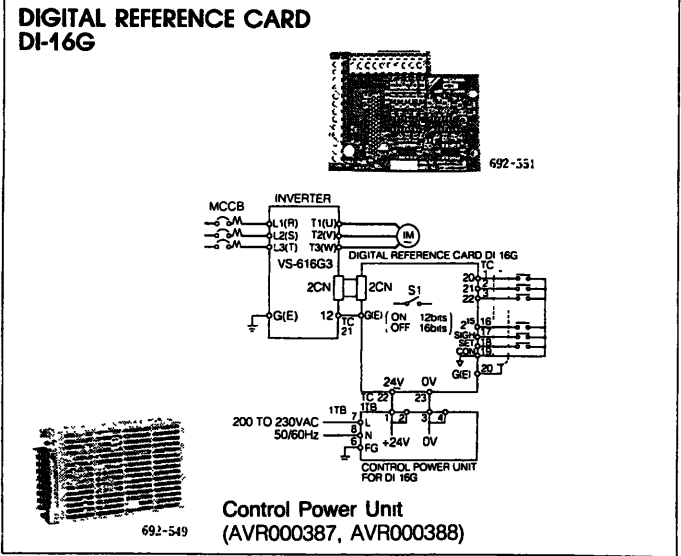
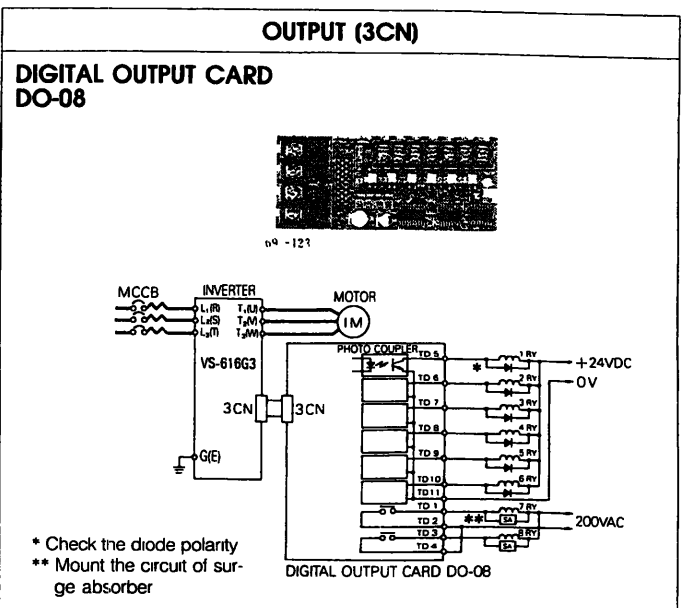
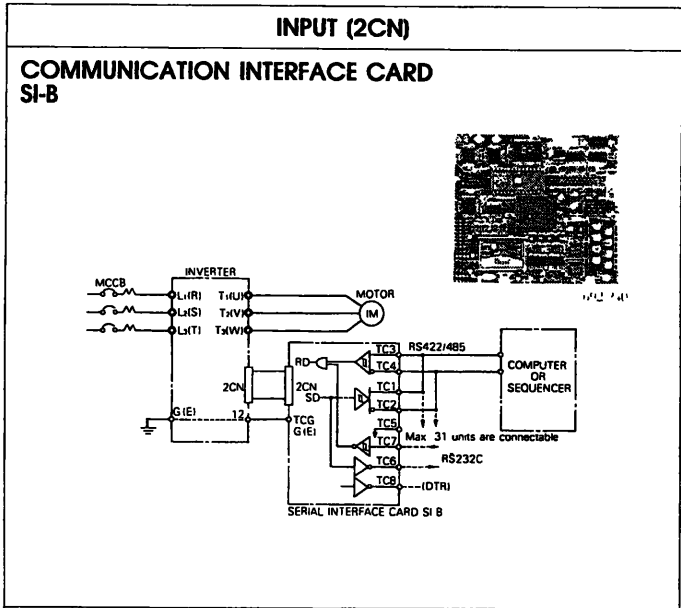



PHOTO COUPLER

PULSE OUTPUT CARD PO-36F

PULSE MEASUREMENT UNIT

*One option card can be mounted on input side (2CN) and output side (3CN) each.



BRAKING RESISTOR, BRAKING UNIT, INVERTER-MOUNTED TYPE (3%ED)

Two kinds of unit mounting are available according to inverter capacity:

Inverter-mounted Type

Braking unit: Standard
Braking resistor: Available on request

Separately-installed Type

Braking unit: 200V class 10HP (7.5kW) or less 400V class 20HP (15kW) or less } Standard
200V class 15HP (11kW) or more } On request
400V class 25HP (18.5kW) or more }

Braking resistor unit: Available on request.

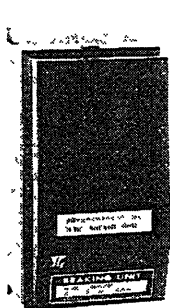

690-47

**BRAKING UNIT
MODEL OF
CDBR**



690-123

**BRAKING RESISTOR
MODEL OF
ERF-150WJ**

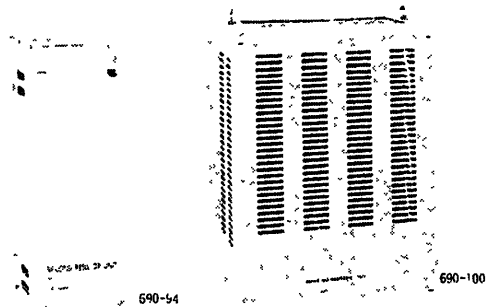

**BRAKING RESISTOR UNIT
MODEL OF LKEB**

* Braking unit as standrad.

† Resistance value per one braking unit.

Note: When connecting braking resistor unit, set system constant Sn-10 2nd-digit to 1.

INVERTER-MOUNTED TYPE (3%ED)

Voltage V	Inverter		Braking Resistor			Braking Torque (3% ED) %	Connectable Min Resistance Value* Ω	
	Max Applicable Motor Unit HP (kW)	Model CIMR- G 3 □	Model ERF- 150WJ	Voltage of Resistance	Code No			No of Used
200 to 230	0.5 (0.4)	20P4	201	200Ω	R007505	1	220	48
	1 (0.75)	20P7	201	200Ω	R007505	1	125	48
	2 (1.5)	21P5	101	100Ω	R007504	1	125	16
	3 (2.2)	22P2	700	70Ω	R007503	1	120	16
380 to 460	5 (3.7)	23P7	620	62Ω	R007510	1	100	16
	0.5 (0.4)	40P4	751	750Ω	R007508	1	230	96
	1 (0.75)	40P7	751	750Ω	R007508	1	130	96
	2 (1.5)	41P5	401	400Ω	R007507	1	125	64
460	3 (2.2)	42P2	301	300Ω	R007506	1	115	64

* Resistance value per one braking unit.

Note: For 500 to 600V class, contact your YASKAWA representative.

SEPARATELY-INSTALLED TYPE (10%ED)

Voltage	Inverter		Braking Unit		Braking Resistor Unit			Braking Torque (10% ED) %	Connectable Min Resistance Value † Ω
	Max Applicable Motor Unit HP (kW)	Model CIMR- G 3 □	Model CDBR - □	No of Used	Model LKEB -	Specifications of Resistor	No of Used Unit		
200 to 230 V	0.5 (0.4)	20P4	*		20P7	70W 200Ω	1	220	48
	1 (0.75)	20P7	*		20P7	70W 200Ω	1	125	48
	2 (1.5)	21P5	*		21P5	260W 100Ω	1	125	16
	3 (2.2)	22P2	*		22P2	260W 70Ω	1	120	16
	5 (3.7)	23P7	*		23P7	390W 40Ω	1	125	16
	7.5 (5.5)	25P5	*		25P5	520W 30Ω	1	115	9.6
	10 (7.5)	27P5	*		27P5	780W 20Ω	1	125	9.6
	15 (11)	2011	2015	1	2011	2400W 13.6Ω	1	125	9.6
	20 (15)	2015	2015	1	2015	3000W 10Ω	1	125	9.6
	25 (18.5)	2018	2022	1	2018	4800W 8Ω	1	125	6.4
	30 (22)	2022	2022	1	2022	4800W 6.8Ω	1	125	6.4
	40 (30)	2030	2015	2	2015	3000W 10Ω	2	125	9.6
	50 (37)	2037	2015	2	2015	3000W 10Ω	2	100	9.6
	60 (45)	2045	2022	2	2022	4800W 6.8Ω	2	120	6.4
75 (55)	2055	2022	2	2022	4800W 6.8Ω	2	100	6.4	
100 (75)	2075	2110	1	2022	4800W 6.8Ω	3	110	1.6	
380 to 460 V	0.5 (0.4)	40P4	*		40P7	70W 750Ω	1	230	96
	1 (0.75)	40P7	*		40P7	70W 750Ω	1	130	96
	2 (1.5)	41P5	*		41P5	260W 400Ω	1	125	64
	3 (2.2)	42P2	*		42P2	260W 250Ω	1	135	64
	5 (3.7)	43P7	*		43P7	390W 150Ω	1	135	32
	7.5 (5.5)	45P5	*		45P5	520W 100Ω	1	135	32
	10 (7.5)	47P5	*		47P5	780W 75Ω	1	130	32
	15 (11)	4011	*		4011	1040W 50Ω	1	135	20
	20 (15)	4015	*		4015	1560W 40Ω	1	125	20
	25 (18.5)	4018	4030	1	4018	4800W 32Ω	1	125	19.2
	30 (22)	4022	4030	1	4022	4800W 27.2Ω	1	125	19.2
	40 (30)	4030	4030	1	4030	6000W 20Ω	1	125	19.2
	50 (37)	4037	4045	1	4037	9600W 16Ω	1	125	12.8
	60 (45)	4045	4045	1	4045	9600W 13.6Ω	1	125	12.8
75 (55)	41L55	4030	2	4030	6000W 20Ω	2	135	19.2	
100 (75)	41L75	4045	2	4045	9600W 13.6Ω	2	145	12.8	
150 (110)	41LA1	4030	1	4030	6000W 20Ω	3	100	19.2	
200 (160)	41LA6	4220	1	4045	9600W 13.6Ω	4	140	3.2	
250 (185)	4185	4220	1	4045	9600W 13.6Ω	4	120	3.2	
300 (220)	4220	4220	1	4037	9600W 16Ω	5	110	3.2	
400 (300)	4300	4220	2	4045	9600W 13.6Ω	6	110	3.2	
500 to 600 V	2 (1.5)	51P5	*		—	400W 250Ω	—	260	90
	3 (2.2)	52P2	*		—	400W 250Ω	—	180	90
	5 (3.7)	53P7	*		—	560W 150Ω	—	180	90
	7.5 (5.5)	55P5	*		—	560W 150Ω	—	125	90
	10 (7.5)	57P5	*		—	750W 100Ω	—	140	90
	15 (11)	5011	*		—	1100W 75Ω	—	125	42
	20 (15)	5015	*		—	1500W 50Ω	—	140	24
	25 (13.5)	5018	*		—	2300W 40Ω	—	140	24
	30 (22)	5022	*		—	2800W 38Ω	—	125	24
	40 (30)	5030	5037	1	—	3900W 33Ω	—	110	24
	50 (37)	5037	5037	1	—	4900W 27Ω	—	110	24
	60 (45)	5045	5037	2	—	5900W 22Ω	—	110	24
	75 (55)	5055	5037	2	—	7200W 18Ω	—	110	24
	100 (75)	5075	5037	2	—	9800W 13.6Ω	—	105	24
120 (90)	5090	5037	3	—	12000W 11Ω	—	110	24	
150 (110)	5110	5037	3	—	15000W 9Ω	—	110	24	
200 (160)	5160	5037	4	—	21000W 6.8Ω	—	100	24	

RAKING RESISTOR UNIT

CONNECTIONS

• Inverter-mounted Type

200 to 230V	0.5 to 5HP (0.4 to 3.7kW)
380 to 460V	0.5 to 3HP (0.4 to 2.2kW)

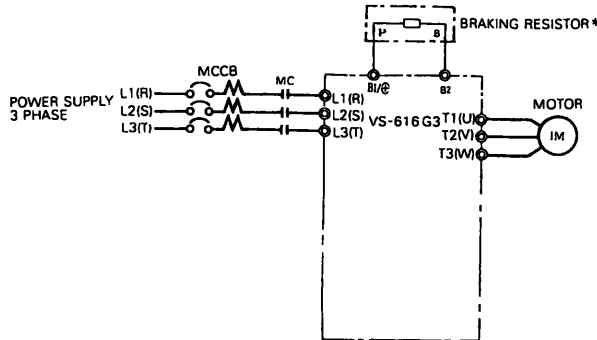

• Separately-installed Type

380 to 460V	15HP (11kW) 20HP (15kW)
-------------	-------------------------

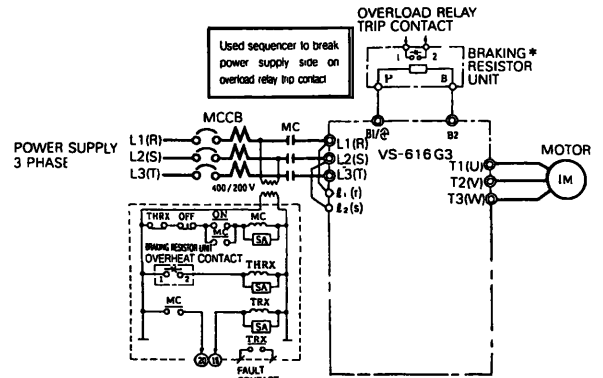

• Separately-installed Type

200 to 230V	0.5 to 10HP (0.4 to 7.5 kW)
380 to 460V	0.5 to 10HP (0.4 to 7.5kW)

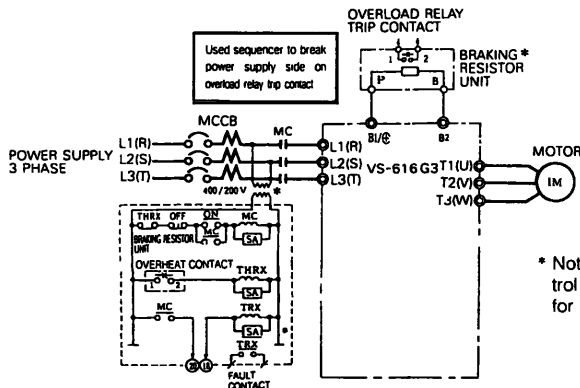

• Separately-installed Type

200 to 230V	15 to 100HP (11 to 75kW)
380 to 460V	25 to 400HP (18.5 to 300kW)

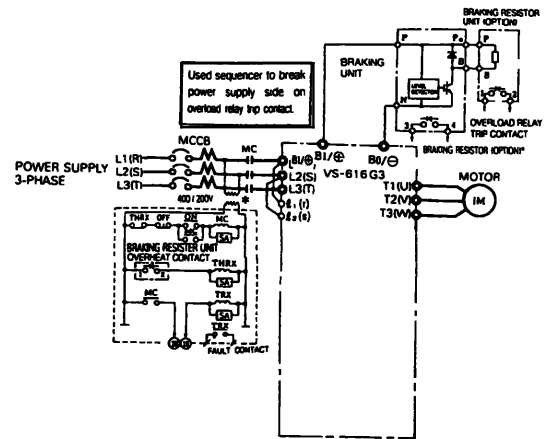

* Not required the control circuit transformer for 200V class

Note: For installing braking resistor unit, set Sn-10, 2nd digit to 1.

PARALLEL CONNECTION OF BRAKING UNIT

For using more than one parallel-connected braking unit, connect and select the connectors as follows.

- Braking units have a MASTER/SLAVE selection connector. Select MASTER side only for braking unit 1 and select SLAVE side for braking units 2 and 3.

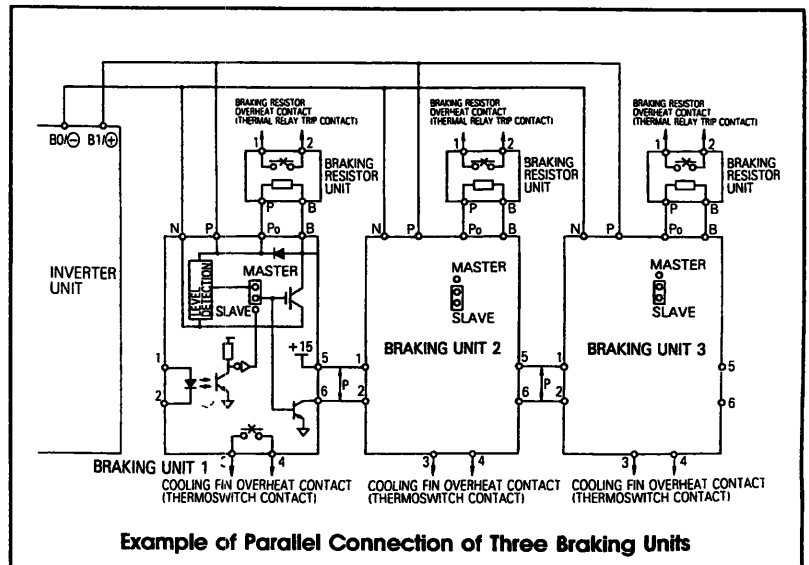

Example of Parallel Connection of Three Braking Units

MOUNTING OF BRAKING RESISTOR

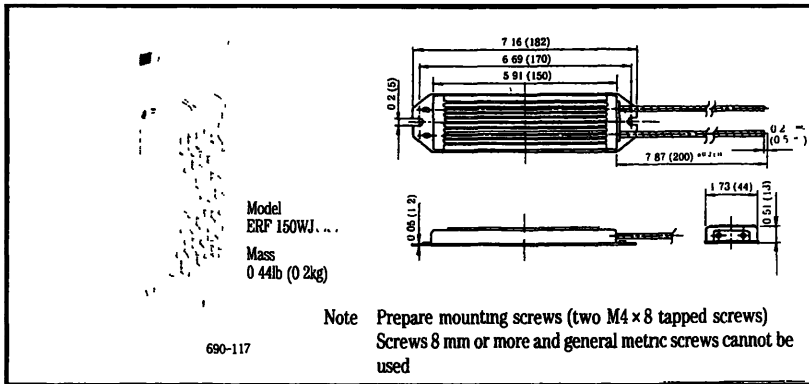

BRAKING UNIT DIMENSIONS in inch (mm)

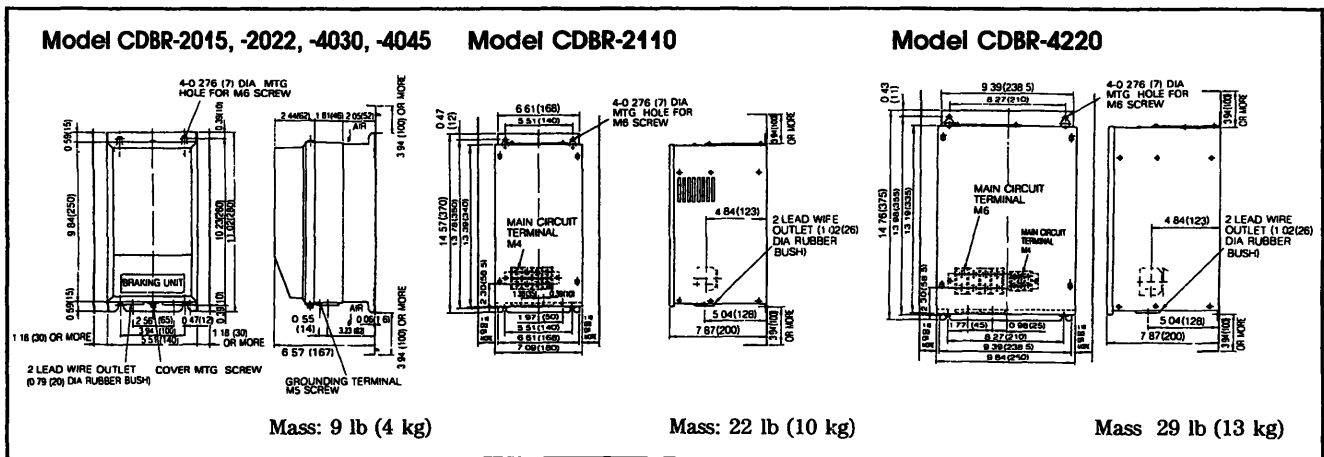

BRAKING RESISTOR UNIT DIMENSIONS in inch (mm)

Voltage	Braking Resistor Unit Model (KEB-□)	DWG	Dimensions in inch (mm)					MTG. Screw	Approx. Mass lb (kg)
			A	B	C	D			
200 to 230V	20P7	1	4 13 (105)	10.83 (275)	1.97 (50)	10.24 (260)	M5 x 3	6.62(3.0)	
	21P5	1	5 12 (130)	13.78 (350)	2.95 (75)	13.19 (335)	M5 x 4	9.93(4.5)	
	22P2	1	5 12 (130)	13.78 (350)	2.95 (75)	13.19 (335)	M5 x 4	9.93(4.5)	
	23P7	1	5 12 (130)	13.78 (350)	2.95 (75)	13.19 (335)	M5 x 4	11.0(5.0)	
	25P5	1	9.84 (250)	13.78 (350)	7.87 (200)	13.19 (335)	M6 x 4	16.6(7.5)	
	27P5	1	9.84 (250)	13.78 (350)	7.87 (200)	13.19 (335)	M6 x 4	18.8(8.5)	
	2011	2	10.47 (266)	21.38 (543)	9.69 (246)	13.39 (340)	M8 x 4	22.1(10)	
	2015	2	14.02 (356)	21.38 (543)	13.23 (336)	13.39 (340)	M8 x 4	33.1(15)	
380 to 460V	2018	2	17.56 (446)	21.38 (543)	16.77 (426)	13.39 (340)	M8 x 4	41.9(19)	
	2022	2	17.56 (446)	21.38 (543)	16.77 (426)	13.39 (340)	M8 x 4	41.9(19)	
	40P7	1	4 13 (105)	10.83 (275)	1.97 (50)	10.24 (260)	M5 x 3	6.62(3.0)	
	41P5	1	5 12 (130)	13.78 (350)	2.95 (75)	13.19 (335)	M5 x 4	9.93(4.5)	
	42P2	1	5 12 (130)	13.78 (350)	2.95 (75)	13.19 (335)	M5 x 4	9.93(4.5)	
	43P7	1	5 12 (130)	13.78 (350)	2.95 (75)	13.19 (335)	M5 x 4	11.0(5.0)	
	45P5	1	9.84 (250)	13.78 (350)	7.87 (200)	13.19 (335)	M6 x 4	16.6(7.5)	
	47P5	1	9.84 (250)	13.78 (350)	7.87 (200)	13.19 (335)	M6 x 4	18.8(8.5)	
	4011	2	13.78 (350)	16.22 (412)	12.99 (330)	12.80 (325)	M6 x 4	35.3(16)	
	4015	2	13.78 (350)	16.22 (412)	12.99 (330)	12.80 (325)	M6 x 4	39.7(18)	
	4018	2	17.56 (446)	21.38 (543)	16.77 (426)	13.39 (340)	M8 x 4	41.9(19)	
	4022	2	17.56 (446)	21.38 (543)	16.77 (426)	13.39 (340)	M8 x 4	41.9(19)	
	4030	2	14.02 (356)	37.64 (956)	13.23 (336)	29.13 (740)	M8 x 4	55.2(25)	
	4037	2	17.56 (446)	37.64 (956)	16.77 (426)	29.13 (740)	M8 x 4	72.8(33)	
	4045	2	17.56 (446)	37.64 (956)	16.77 (426)	29.13 (740)	M8 x 4	72.8(33)	

Note: For 500 to 600V, contact your YASKAWA representative.

Drawing 1

Drawing 2

AC REACTOR (Model UZBA-B, for input, 50/60Hz)

(Example of Connection)

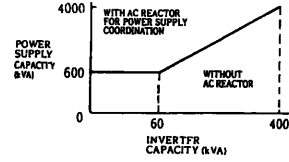
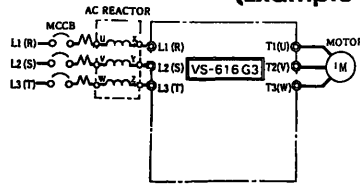
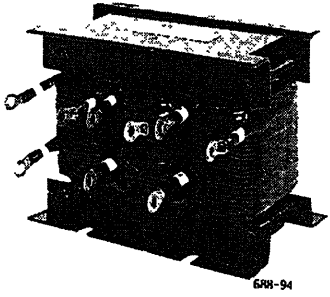

Be sure to connect AC reactor on inverter input side [L₁ (R), L₂ (S), L₃ (T)]

When power capacity is significantly large compared to inverter capacity, or when the power-factor needs to be improved, connect the AC reactor. Select an AC reactor according to the motor capacity.

200 to 230V

Max Applicable Motor Output HP (kW)	Current Value A	Inductance mH	Code No	Drawing	Dimensions in inch (mm)											Approx. Mass lb (kg)	Loss Watt	
					A	B	B1	C	D	E	F	H	J	K	L			M
0.5 (0.4)	2.5	4.2	X002553	1	4.72 (120)	2.80 (71)	-	4.72 (120)	1.57 (40)	1.97 (50)	4.13 (105)	0.79 (20)	M6	0.41 (10.5)	0.28 (7)	M4	5.51 (2.5)	15
1 (0.75)	5	2.1	X002554		4.72 (120)	2.80 (71)	-	4.72 (120)	1.57 (40)	1.97 (50)	4.13 (105)	0.79 (20)	M6	0.41 (10.5)	0.28 (7)	M4	5.51 (2.5)	15
2 (1.5)	10	1.1	X002489		5.12 (130)	3.46 (88)	-	5.12 (130)	1.97 (50)	2.56 (65)	5.12 (130)	0.87 (22)	M6	0.45 (11.5)	0.28 (7)	M4	6.62 (3)	25
3 (2.2)	15	0.71	X002490		5.12 (130)	3.46 (88)	-	5.12 (130)	1.97 (50)	2.56 (65)	5.12 (130)	0.87 (22)	M6	0.45 (11.5)	0.28 (7)	M4	6.62 (3)	25
5 (3.7)	20	0.53	X002491	2	5.12 (130)	3.46 (88)	4.49 (114)	4.13 (105)	1.37 (35)	2.56 (65)	5.12 (130)	0.87 (22)	M6	0.45 (11.5)	0.28 (7)	M5	6.62 (3)	35
7.5 (5.5)	30	0.35	X002492		5.12 (130)	3.46 (88)	4.49 (114)	4.13 (105)	1.37 (35)	2.56 (65)	5.12 (130)	0.87 (22)	M6	0.45 (11.5)	0.28 (7)	M5	6.62 (3)	35
10 (7.5)	40	0.265	X002493		5.12 (130)	3.46 (88)	5.47 (139)	4.13 (105)	1.37 (35)	2.56 (65)	5.12 (130)	0.87 (22)	M6	0.45 (11.5)	0.28 (7)	M6	8.82 (4)	50
15 (11)	60	0.18	X002495		6.30 (160)	4.13 (105)	5.81 (147.5)	5.12 (130)	2.86 (75)	3.35 (85)	6.30 (160)	0.98 (25)	M6	0.39 (10)	0.28 (7)	M6	13.23 (6)	65
20 (15)	80	0.13	X002497		7.09 (180)	3.94 (100)	6.10 (155)	5.91 (150)	2.95 (75)	3.15 (80)	7.09 (180)	0.98 (25)	M6	0.39 (10)	0.28 (7)	M8	17.64 (8)	75
25 (18.5)	90	0.12	X002498		7.09 (180)	3.94 (100)	6.10 (155)	5.91 (150)	2.95 (75)	3.15 (80)	7.09 (180)	0.98 (25)	M6	0.39 (10)	0.28 (7)	M8	17.64 (8)	90
30 (22)	120	0.09	X002555		7.09 (180)	3.94 (100)	6.10 (155)	5.91 (150)	2.95 (75)	3.15 (80)	7.09 (180)	0.98 (25)	M6	0.39 (10)	0.28 (7)	M10	17.64 (8)	90
40 (30)	160	0.07	X002556		8.27 (210)	3.94 (100)	6.69 (170)	6.89 (175)	2.95 (75)	3.15 (80)	8.07 (205)	0.98 (25)	M6	0.39 (10)	0.28 (7)	M10	26.46 (12)	100
50 (37)	200	0.05	X002557		8.27 (210)	4.53 (115)	7.20 (182.8)	6.89 (175)	2.95 (75)	3.15 (80)	8.07 (205)	0.98 (25)	M6	0.39 (10)	0.28 (7)	M10	33.07 (15)	110
60 (45)	240	0.044	X002558		9.45 (240)	4.96 (126)	8.58 (218)	8.47±0.2 (215±5)	5.91 (150)	4.33 (110)	9.45 (240)	0.98 (25)	M8	0.32 (8)	0.28 (7)	M10	50.71 (23)	125
75 (55)	280	0.038	X002559		9.45 (240)	4.96 (126)	8.58 (218)	8.47±0.2 (215±5)	5.91 (150)	4.33 (110)	9.45 (240)	0.98 (25)	M8	0.32 (8)	0.28 (7)	M12	50.71 (23)	130
100 (75)	360	0.026	X002560		10.63 (270)	6.28 (160)	9.48 (241)	9.06±0.2 (230±5)	6.91 (175)	5.12 (130)	10.24 (260)	1.58 (40)	M8	0.63 (15)	0.39 (10)	M12	70.56 (32)	145

380 to 460V

Max Applicable Motor Output HP (kW)	Current Value A	Inductance mH	Code No	Drawing	Dimensions in inch (mm)											Approx. Mass lb (kg)	Loss Watt		
					A	B	B1	C	D	E	F	H	J	K	L			M	
0.5 (0.4)	1.3	18.0	X002561	1	4.72 (120)	2.80 (71)	-	4.72 (120)	1.57 (40)	1.97 (50)	4.13 (105)	0.79 (20)	M6	0.41 (10.5)	0.28 (7)	M4	5.51 (2.5)	15	
1 (0.75)	2.5	8.4	X002562		4.72 (120)	2.80 (71)	-	4.72 (120)	1.57 (40)	1.97 (50)	4.13 (105)	0.79 (20)	M6	0.41 (10.5)	0.28 (7)	M4	5.51 (2.5)	15	
2 (1.5)	5	4.2	X002563		5.12 (130)	3.46 (88)	-	5.12 (130)	1.97 (50)	2.76 (70)	5.12 (130)	0.87 (22)	M6	0.35 (9)	0.28 (7)	M4	6.62 (3)	25	
3 (2.2)	7.5	3.6	X002564		5.12 (130)	3.46 (88)	-	5.12 (130)	1.97 (50)	2.76 (70)	5.12 (130)	0.87 (22)	M6	0.35 (9)	0.28 (7)	M4	6.62 (3)	25	
5 (3.7)	10	2.2	X002500	2	5.12 (130)	3.46 (88)	-	5.12 (130)	1.97 (50)	2.56 (65)	5.12 (130)	0.87 (22)	M6	0.45 (11.5)	0.28 (7)	M4	6.62 (3)	25	
7.5 (5.5)	15	1.4	X002501		5.12 (130)	3.46 (88)	-	5.12 (130)	1.97 (50)	2.56 (65)	5.12 (130)	0.87 (22)	M6	0.45 (11.5)	0.28 (7)	M4	6.62 (3)	25	
10 (7.5)	20	1.06	X002502		6.30 (160)	3.94 (100)	4.53 (115)	5.12 (130)	2.95 (75)	2.76 (70)	6.30 (160)	0.98 (25)	M6	0.39 (10)	0.28 (7)	M5	11.08 (5)	50	
15 (11)	30	0.7	X002503		6.30 (160)	4.13 (105)	5.22 (132.5)	5.12 (130)	2.95 (75)	3.35 (85)	6.30 (160)	0.98 (25)	M6	0.39 (10)	0.28 (7)	M5	13.23 (6)	65	
20 (15)	40	0.53	X002504		7.09 (180)	3.94 (100)	5.51 (140)	5.91 (150)	2.95 (75)	3.15 (80)	7.09 (180)	0.98 (25)	M6	0.39 (10)	0.28 (7)	M6	17.64 (8)	90	
25 (18.5)	50	0.42	X002505		7.09 (180)	3.94 (100)	5.51 (140)	5.91 (150)	2.95 (75)	3.15 (80)	7.09 (180)	0.98 (25)	M6	0.39 (10)	0.28 (7)	M6	17.64 (8)	90	
30 (22)	60	0.36	X002506		7.09 (180)	3.94 (100)	5.71 (145)	5.91 (150)	2.95 (75)	3.15 (80)	7.09 (180)	0.98 (25)	M6	0.39 (10)	0.28 (7)	M6	17.64 (8)	90	
40 (30)	80	0.26	X002508		8.27 (210)	3.94 (100)	6.10 (155)	6.89 (175)	2.95 (75)	3.15 (80)	8.07 (205)	0.98 (25)	M6	0.39 (10)	0.28 (7)	M6	26.46 (12)	100	
50 (37)	90	0.24	X002509		8.27 (210)	4.53 (115)	6.96 (177.5)	6.89 (175)	2.95 (75)	3.15 (80)	8.07 (205)	0.98 (25)	M6	0.39 (10)	0.28 (7)	M6	33.07 (15)	110	
60 (45)	120	0.18	X002566		9.45 (240)	4.96 (126)	7.86 (200.5)	8.07±0.2 (205±5)	5.91 (150)	4.33 (110)	9.45 (240)	0.98 (25)	M8	0.31 (8)	0.39 (10)	M10	50.71 (23)	130	
75 (55)	150	0.15	X002567		9.45 (240)	4.96 (126)	7.86 (200.5)	8.07±0.2 (205±5)	5.91 (150)	4.33 (110)	9.45 (240)	0.98 (25)	M8	0.32 (8)	0.39 (10)	M10	50.71 (23)	150	
100 (75)	200	0.11	X002568		10.63 (270)	6.28 (160)	9.10 (231)	9.06±0.2 (230±5)	6.91 (175)	5.12 (130)	10.24 (260)	1.58 (40)	M8	0.63 (15)	0.39 (10)	M10	70.56 (32)	135	
150 (110)	250	0.09	X002569		10.63 (270)	6.28 (160)	9.10 (231)	9.06±0.2 (230±5)	6.91 (175)	5.12 (130)	10.24 (260)	1.58 (40)	M8	0.63 (15)	0.39 (10)	M10	70.56 (32)	135	
200 (160)	330	0.06	X002570		12.60 (320)	6.50 (165)	9.96 (253)	9.06±0.2 (230±5)	6.91 (175)	5.12 (130)	12.60 (320)	1.58 (40)	M10	0.69 (17.5)	0.47 (12)	M12	121.27 (55)	200	
250 (185)	490	0.04	X002690		-	13.0 (330)	6.93 (176)	11.54 (293)	12.4±0.2 (315±5)	5.91 (150)	5.91 (150)	12.60 (320)	1.57 (40)	M10	0.51 (13)	0.47 (12)	M12	132.38 (60)	340
300 (220)	660	0.03	X002691			13.0 (330)	8.50 (216)	13.9 (353)	12.4±0.2 (315±5)	5.91 (150)	7.28 (185)	12.60 (320)	1.57 (40)	M10	0.61 (15.5)	0.71 (18)	M16	176.37 (80)	310

Note: For 500 to 600V, contact your YASKAWA representative.

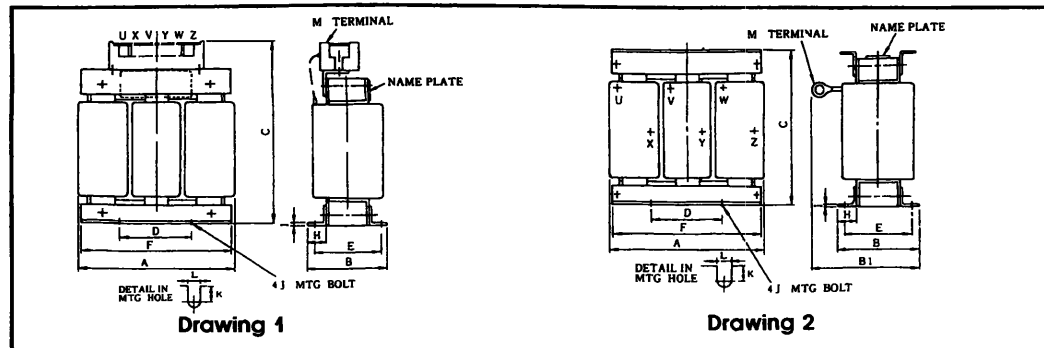

MOLDED-CASE CIRCUIT BREAKER (MCCB) AND POWER SUPPLY MAGNETIC CONTACTOR (MC)

Be sure to connect MCCBs between power supply and VS-616G3 input terminals L1 (R), L2 (S), L3 (T). Recommended MCCBs are listed as follows. Connect MC if required.

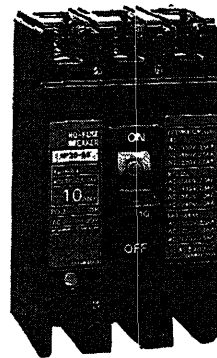

MOLDED-CASE CIRCUIT BREAKER (MCCB)

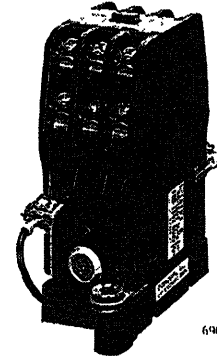

POWER SUPPLY MAGNETIC CONTACTOR (MC)

200 to 230V

VS-616G3			Molded-Case Circuit Breaker (MCCB)		YASKAWA Magnetic Contactor (Model MC)
Model CIMR-G3	Capacity kVA	Rated Output Current A	Model	Rated Current A	
20P4	1.4	3.2	NF 30	5	HI - 7E
20P7	2.1	4.8	NF 30	10	HI - 7E
21P5	2.7	6.4	NF 30	20	HI - 10-2 E
22P2	4.1	9.6	NF 30	20	HI - 10-2 E
23P7	6.9	16	NF 30	30	HI - 20 E
25P5	10.3	24	NF 50	50	HI - 30 E
27P5	13.7	32	NF 100	60	HI - 50 E
2011	20.6	48	NF 100	100	HI - 50 E
2015	27.4	64	NF 100	100	HI - 80 E
2018	34	80	NF 225	150	HI - 100 E
2022	41	96	NF 225	150	HI - 100 E
2030	54	130	NF 225	225	HI - 100 E
2037	68	160	NF 225	225	HI - 100 E
2045	78	183	NF 400	300	HI - 200 E
2055	95	224	NF 400	400	HI - 300 E
2075	130	300	NF 600	600	HI - 500 E

380 to 460V

VS-616G3			Molded-Case Circuit Breaker (MCCB)		YASKAWA Magnetic Contactor (Model MC)
Model CIMR-G3	Capacity kVA	Rated Output Current A	Model	Rated Current A	
40P4	1.4	1.6	NF 30	5	HI - 7E
40P7	2.2	2.6	NF 30	5	HI - 7E
41P5	3.4	4.0	NF 30	10	HI - 10-2 E
42P2	4.1	4.8	NF 30	10	HI - 10-2 E
43P7	6.9	8	NF 30	20	HI - 20 E
45P5	10.3	12	NF 30	20	HI - 20 E
47P5	13.7	16	NF 30	30	HI - 20 E
4011	20.6	24	NF 50	50	HI - 30 E
4015	27.4	32	NF 100	60	HI - 50 E
4018	34	40	NF 100	75	HI - 50 E
4022	41	48	NF 100	100	HI - 50 E
4030	54	64	NF 100	100	HI - 80 E
4037	68	80	NF 225	150	HI - 100 E
4045, 4L45	82	96	NF 225	150	HI - 100 E
4055	110	128	NF 225	225	HI - 125 E
4075	140	165	NF 400	300	HI - 200 E
4110	200	224	NF 400	400	HI - 300 E
4160	250	300	NF 600	600	HI - 500 E
4185	290	340	NF 600	600	HI - 500 E
4220	380	450	NF 800	800	HU - 4893E
4300	510	600	NF 1000	1000	HU - 593 E

500 to 600V

VS-616G3			Molded-Case Circuit Breaker (MCCB)		YASKAWA Magnetic Contactor (Model MC)
Model CIMR-G3	Capacity kVA	Rated Output Current A	Model	Rated Current A	
U51P5	2	3.5	NF 30	10	HI - 10-2 E
U52P2	3	4.1	NF 30	10	HI - 10-2 E
U53P7	5	6.3	NF 30	20	HI - 10-2 E
U55P5	7.5	9.8	NF 30	20	HI - 10-2 E
U57P5	10	12.5	NF 30	20	HI - 20 E
U5011	15	17	NF 30	30	HI - 20 E
U5015	20	22	NF 50	50	HI - 30 E
U5018	25	27	NF 100	60	HI - 50 E
U5022	30	32	NF 100	60	HI - 50 E
U5030	40	41	NF 100	100	HI - 50 E
U5037	50	52	NF 100	100	HI - 80 E
U5045	60	62	NF 100	100	HI - 80 E
U5055	75	77	NF 225	150	HI - 100 E
U5075	100	99	NF 225	225	HI - 125 E
U5090	125	130	NF 225	225	HI - 125 E
U5110	150	172	NF 400	300	HI - 200 E
U5160	200	200	NF 400	400	HI - 300 E

SURGE SUPPRESSOR (Manufactured by Marcon Electronics)

Use surge suppressors for coils in electromagnetic contactors, control relays, electromagnetic valves, and electromagnetic brakes used as VS-616G3 peripheral units.

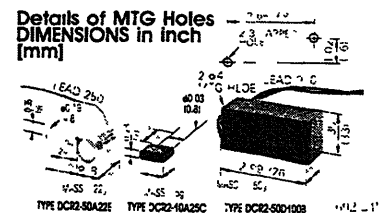

Coils of Magnetic Contactor and Control Relay		Surge Suppressor*		
		Model	Specifications	Code No.
200 to 230V	Large-size Magnetic Contactors	DCR2-50A22E	220VAC 0.5 μ F + 200 Ω	C002417
	Control Relay LY-2, -3(OMRON) HH-22, -23(Fuji) MM-2, -4(OMRON)	DCR2-10A25C	250 VAC 0.1 μ F + 100 Ω	C002482
380 to 460V Units		DCR2-50D100B	1000VDC 0.5 μ F + 220 Ω	C002630

* Made by MARCON Electronics.

NOISE FILTER

INPUT NOISE FILTER



602-576

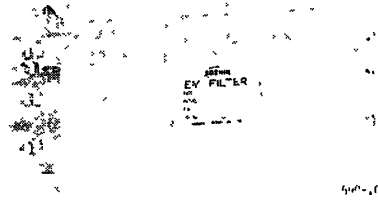

500-104

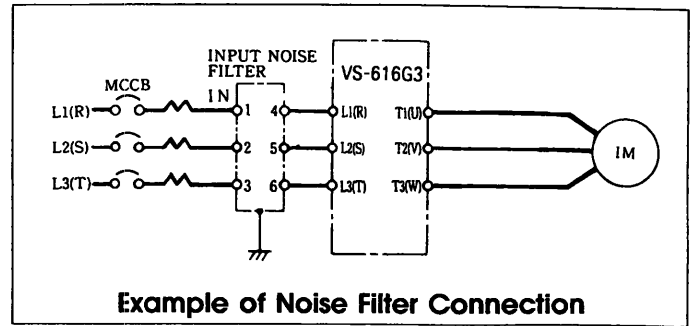

Example of Noise Filter Connection

Note: Be sure to connect input noise filter on inverter input side [L₁ (R), L₂ (S), L₃ (T)]

Manufactured
by YASKAWA

Manufactured by
Soshin Electric Co., Ltd.

200 to 230V

Inverter Model CIMR - G 3	Max Applicable Motor Output HP (kW)	Noise Filter without Case				Noise Filter with Case				Noise Filter by Soshin Electric Co., Ltd.			
		Model LNFD -	Code No. 72600 -	Q'ty	Rated Current A	Model LNFD -	Code No 72600 -	Q'ty	Rated Current A	Model	Code No.	Q'ty	Rated Current A
20P4	0.5 (0.4)	2103DY	D2103DY	1	10	2103HY	D2103HY	1	10	—	—	—	—
20P7	1 (0.75)	2103DY	D2103DY	1	10	2103HY	D2103HY	1	10	—	—	—	—
21P5	2 (1.5)	2153DY	D2153DY	1	15	2153HY	D2153HY	1	15	—	—	—	—
22P2	3 (2.2)	2203DY	D2203DY	1	20	2203HY	D2203HY	1	20	—	—	—	—
23P7	5 (3.7)	2303DY	D2303DY	1	30	2303HY	D2303HY	1	30	—	—	—	—
25P5	7.5 (5.5)	2203DY	D2203DY	2	40	2203HY	D2203HY	2	40	HF3040A-Z	FIL000057	1	40
27P5	10 (7.5)	2303DY	D2303DY	2	60	2303HY	D2303HY	2	60	HF3060A-Z	FIL000125	1	60
2011	15 (11)	2303DY	D2303DY	3	90	2303HY	D2303HY	3	90	HF3100A-Z	FIL000060	1	100
2015	20 (15)	2303DY	D2303DY	4	120	2303HY	D2303HY	4	120	HF3150A-Z	FIL000077	1	150
2018	25 (18.5)	2303DY	D2303DY	5	150	2303HY	D2303HY	5	150	HF3150A-Z	FIL000077	1	150
2022	30 (22)	2303DY	D2303DY	6	180	2303HY	D2303HY	6	180	HF3200A-Z	FIL000078	1	200
2030	40 (30)	—	—	—	—	—	—	—	—	HF3200A-Z	FIL000078	1	200
2037	50 (37)	—	—	—	—	—	—	—	—	HF3240A-Z	FIL001001	1	240
2045	60 (45)	—	—	—	—	—	—	—	—	HF3240A-Z	FIL001001	1	240
2055	75 (55)	—	—	—	—	—	—	—	—	HF3150A-Z	FIL000077	2	300
2075	100 (75)	—	—	—	—	—	—	—	—	HF3200A-Z	FIL000078	2	400

380 to 460V

Inverter Model CIMR - G 3	Max Applicable Motor Output HP (kW)	Noise Filter without Case				Noise Filter with Case				Noise Filter by Soshin Electric Co., Ltd.			
		Model LNFD -	Code No. 72600 -	Q'ty	Rated Current A	Model LNFD -	Code No 72600 -	Q'ty	Rated Current A	Model	Code No.	Q'ty	Rated Current A
40P4	0.5 (0.4)	4053DY	D4053DY	1	5	4053HY	D4053HY	1	5	—	—	—	—
40P7	1 (0.75)	4053DY	D4053DY	1	5	4053HY	D4053HY	1	5	—	—	—	—
41P5	2 (1.5)	4103DY	D4103DY	1	10	4103HY	D4103HY	1	10	—	—	—	—
42P2	3 (2.2)	4103DY	D4103DY	1	10	4103HY	D4103HY	1	10	—	—	—	—
43P7	5 (3.7)	4153DY	D4153DY	1	15	4153HY	D4153HY	1	15	—	—	—	—
45P5	7.5 (5.5)	4203DY	D4203DY	1	20	4203HY	D4203HY	1	20	—	—	—	—
47P5	10 (7.5)	4303DY	D4303DY	1	30	4303HY	D4303HY	1	30	—	—	—	—
4011	15 (11)	4203DY	D4203DY	2	40	4203HY	D4203HY	2	40	HF3040C-Z	FIL000066	1	40
4015	20 (15)	4303DY	D4303DY	2	60	4303HY	D4303HY	2	60	HF3060C-Z	FIL000079	1	60
4018	25 (18.5)	4303DY	D4303DY	3	90	4303HY	D4303HY	3	90	HF3080C-Z	FIL000080	1	80
4022	30 (22)	4303DY	D4303DY	3	90	4303HY	D4303HY	3	90	HF3080C-Z	FIL000080	1	80
4030	40 (30)	4303DY	D4303DY	4	120	4303HY	D4303HY	4	120	HF3150C-Z	FIL000082	1	150
4037	50 (37)	4303DY	D4303DY	5	150	4303HY	D4303HY	5	150	HF3150C-Z	FIL000082	1	150
4045	60 (45)	4303DY	D4303DY	6	180	4303HY	D4303HY	6	180	HF3200C-Z	FIL000083	1	200
4L45	60 (45)	4303DY	D4303DY	6	180	4303HY	D4303HY	6	180	HF3200C-Z	FIL000083	1	200
4055	75 (55)	—	—	—	—	—	—	—	—	HF3200C-Z	FIL000083	1	200
4075	100 (75)	—	—	—	—	—	—	—	—	HF3150C-Z	FIL000082	2	300
4110	150 (110)	—	—	—	—	—	—	—	—	HF3150C-Z	FIL000082	2	300
4160	200 (160)	—	—	—	—	—	—	—	—	HF3200C-Z	FIL000083	2	400
4185	250 (185)	—	—	—	—	—	—	—	—	HF3200C-Z	FIL000083	3	600
4220	300 (220)	—	—	—	—	—	—	—	—	HF3200C-Z	FIL000083	3	600
4300	400 (300)	—	—	—	—	—	—	—	—	HF3200C-Z	FIL000083	4	800

Note: For 500 to 600V, contact your YASKAWA representative.

NOISE FILTER DIMENSIONS in inch (mm)

Without Case

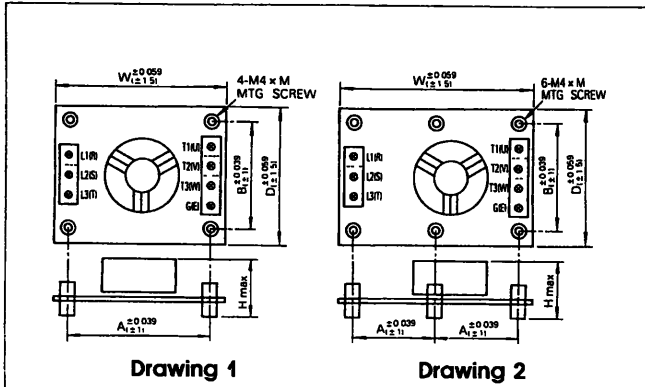

Model LNFD -	Code No 72600 -	Dwg No	W	D	H	A	A'	B	M	Mass lb (kg)
2103 DY	D 2103 DY	1	4.72 (120)	3.15 (80)	2.17 (55)	4.25 (108)	—	2.68 (68)	0.79 (20)	0.44 (0.2)
2153 DY	D 2153 DY	1	4.72 (120)	3.15 (80)	2.17 (55)	4.25 (108)	—	2.68 (68)	0.79 (20)	0.44 (0.2)
2203 DY	D 2203 DY	1	6.69 (170)	3.54 (90)	2.76 (70)	6.22 (158)	—	3.07 (78)	0.79 (20)	0.88 (0.4)
2303 DY	D 2303 DY	2	6.69 (170)	4.33 (110)	2.76 (70)	—	3.11 (79)	3.86 (98)	0.79 (20)	1.10 (0.5)
4053 DY	D 4053 DY	2	6.69 (170)	5.12 (130)	2.95 (75)	—	3.11 (79)	4.65 (118)	1.18 (30)	0.66 (0.3)
4103 DY	D 4103 DY	2	6.69 (170)	5.12 (130)	3.74 (95)	—	3.11 (79)	4.65 (118)	1.18 (30)	0.88 (0.4)
4153 DY	D 4153 DY	2	6.69 (170)	5.12 (130)	3.74 (95)	—	3.11 (79)	4.65 (118)	1.18 (30)	0.88 (0.4)
4203 DY	D 4203 DY	2	7.87 (200)	5.71 (145)	3.94 (100)	—	3.70 (94)	5.24 (133)	1.18 (30)	1.10 (0.5)
4303 DY	D 4303 DY	2	7.87 (200)	5.71 (145)	3.94 (100)	—	3.70 (94)	5.24 (133)	1.18 (30)	1.32 (0.6)

With Case

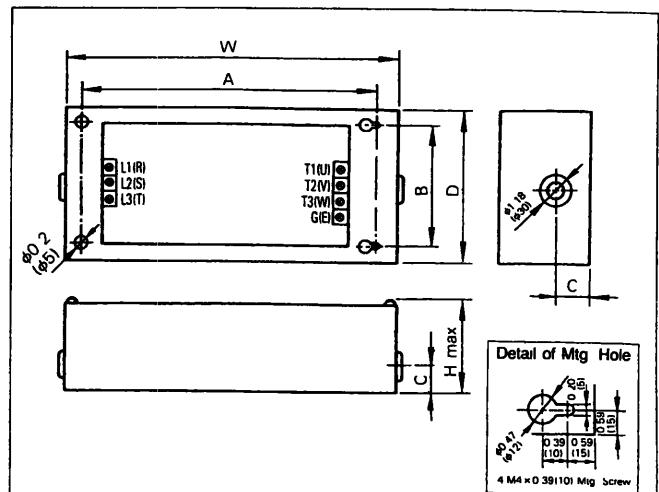

Model LNFD -	Code No 72600 -	W	D	H	A	B	C	Mass lb (kg)
2103 HY	D 2103 HY	7.28 (185)	3.74 (95)	3.35 (85)	6.10 (155)	2.56 (65)	1.30 (33)	1.98 (0.9)
2153 HY	D 2153 HY	7.28 (185)	3.74 (95)	3.35 (85)	6.10 (155)	2.56 (65)	1.30 (33)	1.98 (0.9)
2203 HY	D 2203 HY	9.45 (240)	4.92 (125)	3.94 (100)	8.27 (210)	3.74 (95)	1.30 (33)	3.31 (1.5)
2303 HY	D 2303 HY	9.45 (240)	4.92 (125)	3.94 (100)	8.27 (210)	3.74 (95)	1.30 (33)	3.53 (1.6)
4053 HY	D 4053 HY	9.25 (235)	5.51 (140)	4.72 (120)	8.07 (205)	4.33 (110)	1.69 (43)	3.53 (1.6)
4103 HY	D 4103 HY	9.25 (235)	5.51 (140)	4.72 (120)	8.07 (205)	4.33 (110)	1.69 (43)	3.75 (1.7)
4153 HY	D 4153 HY	9.25 (235)	5.51 (140)	4.72 (120)	8.07 (205)	4.33 (110)	1.69 (43)	3.75 (1.7)
4203 HY	D 4203 HY	10.63 (270)	6.10 (155)	4.92 (125)	9.45 (240)	4.92 (125)	1.69 (43)	4.85 (2.2)
4303 HY	D 4303 HY	10.63 (270)	6.10 (155)	4.92 (125)	9.45 (240)	4.92 (125)	1.69 (43)	4.85 (2.2)

NOISE FILTER DIMENSIONS in inch (mm)

(Manufactured by Soshin Electric)

Model	DWG	A	B	C	D	E	F	G	H	J	K	L	M	N	P	Q	Mass lb (kg)	
HF3040A-Z	1	13.98 (355)	12.99 (330)	12.06 (302)	11.22 (285)	4.72 (120)	3.54 (90)	2.76 (70)	3.15 (80)	1.57 (40)	0.47 (12)	R0.13 (R3.25 8 Length)	±0.26 (±6.5)	M5	M4	1.18 (30)	10.6 (4.8)	
HF3060A-Z		16.54 (420)	15.51 (394)	14.96 (380)	13.39 (340)	6.30 (160)	5.12 (130)	3.94 (100)	3.94 (100)	1.97 (50)	0.59 (15)	±0.26 (±6.5)	M6	M6	M6	1.97 (50)	22.0 (10)	
HF3100A-Z	2	11.81 (300)	10.24 (260)	9.45 (240)	8.66 (220)	16.54 (420)	4.13 (105)	3.82 (97)	4.13 (105)	3.94 (100)	2.17 (55)	±0.26 (±6.5)	M10	M6	M6	41.9 (19)		
HF3150A-Z		12.80 (325)	10.63 (270)	9.84 (250)	9.06 (230)	17.72 (450)	4.65 (118)	3.90 (99)	4.33 (110)	0.98 (25)	4.74 (120)	2.36 (60)	±0.26 (±6.5)	M12	M6	M6	61.7 (28)	
HF3200A-Z	1	13.58 (345)	11.42 (290)	10.63 (270)	9.84 (250)	18.90 (480)	4.53 (115)	4.53 (115)	5.91 (150)	2.95 (75)	±0.26 (±6.5)	M12	M6	M6	M6	77.2 (35)		
HF3040C-Z		13.98 (355)	12.99 (330)	12.06 (302)	11.22 (285)	4.72 (120)	3.54 (90)	2.76 (70)	3.15 (80)	1.57 (40)	0.47 (12)	R0.13 (R3.25 8 Length)	±0.26 (±6.5)	M5	M4	M4	1.18 (30)	10.6 (4.8)
HF3060C-Z	1	16.54 (420)	15.51 (394)	14.96 (380)	13.39 (340)	6.30 (160)	5.12 (130)	3.94 (100)	3.94 (100)	1.97 (50)	0.59 (15)	±0.26 (±6.5)	M6	M6	M6	M6	22.0 (10)	
HF3080C-Z		16.41 (410)	14.96 (380)	14.96 (380)	13.39 (340)	6.30 (160)	5.12 (130)	3.94 (100)	3.94 (100)	1.97 (50)	0.59 (15)	±0.26 (±6.5)	M8	M6	M6	M6	24.3 (11)	
HF3150C-Z	2	12.80 (325)	10.63 (270)	9.84 (250)	9.06 (230)	17.72 (450)	4.65 (118)	3.90 (99)	4.33 (110)	0.98 (25)	4.74 (120)	2.36 (60)	±0.26 (±6.5)	M12	M6	M6	61.7 (28)	
HF3200C-Z		13.58 (345)	11.42 (290)	10.63 (270)	9.84 (250)	18.90 (480)	4.53 (115)	4.53 (115)	5.91 (150)	2.95 (75)	±0.26 (±6.5)	M12	M6	M6	M6	77.2 (35)		

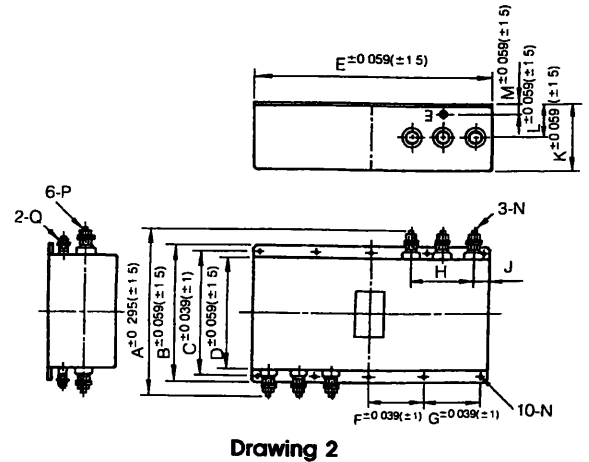
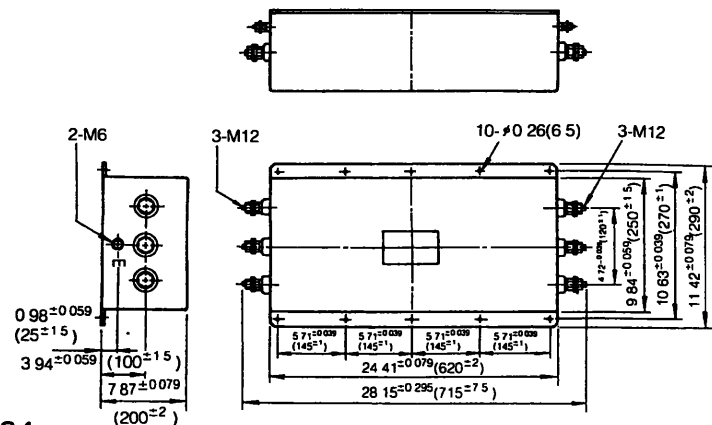
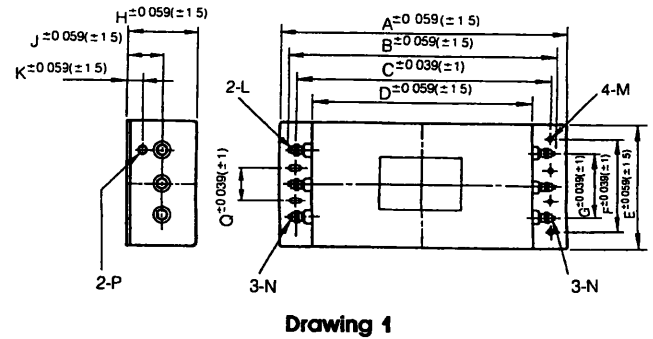

VDE STANDARD CONFORMING INPUT NOISE FILTER

(Manufactured by Soshin Electric)

200 to 230V

Max Applicable Motor Output Hp (kW)	Inverter Capacity kVA	Input Noise Filter		
		Model	Rated Current A	Code No
0.5 (0.4)	1.4	HF3005A-DP	5	FIL 000084
1 (0.75)	2.1	HF3010A-DP	10	FIL 000085
2 (1.5)	2.7	HF3010A-DP	10	FIL 000085
3 (2.2)	4.1	HF3015A-DP	15	FIL 000086
5 (3.7)	6.9	HF3030A-DP	30	FIL 000088
7.5 (5.5)	10.3	HF3040A-DP	40	FIL 000089

Note For 200V class with an output of 10HP (7.5kW) or greater, for 400V, 575V class motors, contact your YASKAWA representative

Model	Dimensions in inch (mm)													Max lb (kg)		
	A	B	C	D	E	F	G	H	J	K	L	M	N		P	Q
HF3005A-DP																7.28 (3.3)
HF3010A-DP	13.98 (355)	12.72 (323)	14.96 (380)	11.22 (285)	4.72 (120)	3.54 (90)	2.76 (70)	3.15 (80)	1.57 (40)	0.47 (12)		Ø0.26 (6.5)	M4	M4	1.18 (30)	7.18 (3.25)
HF3015A-DP											R0.13, 0.31 Length (R3.25, 8 Length)					7.94 (3.6)
HF3020A-DP																8.38 (3.8)
HF3030A-DP	16.54 (420)	15.16 (389)	14.96 (380)	13.28 (337)	6.30 (160)	5.12 (130)	3.54 (90)	3.94 (100)	1.97 (50)	0.59 (15)		Ø0.26 (6.5)	M5	M4	1.97 (50)	17.6 (8)
HF3040A-DP	20.87 (530)	19.49 (495)	19.29 (490)	17.72 (450)	6.30 (160)	5.12 (130)	3.54 (90)	3.94 (100)	1.97 (50)	0.59 (15)		Ø0.26 (6.5)	M5	M4	1.97 (50)	22.1 (10.5)

Note See Drawing 1 on page 78

Noise Attenuation Characteristics

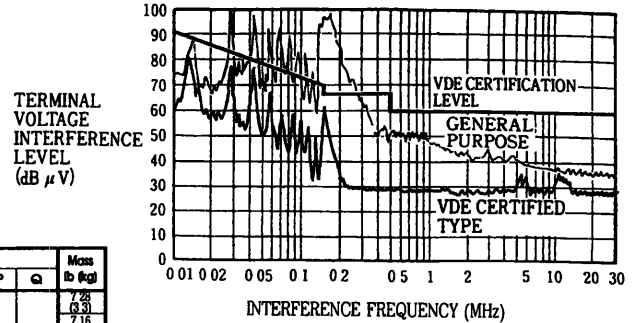

OUTPUT NOISE FILTER

(Tohoku Metal Industries Co., Ltd.)

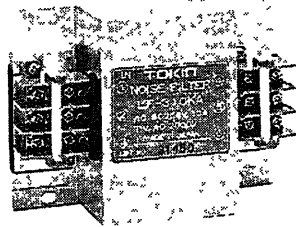

64-14

200 to 230V

Max Applicable Motor Output HP (kW)	Inverter Capacity kVA	Output Noise Filter		
		Model	Rated Current A	Code No
0.5 (0.4)	1.4	LF-310KA	10	FIL 000068
1 (0.75)	2.1	LF-310KA	10	FIL 000068
2 (1.5)	2.7	LF-310KA	10	FIL 000068
3 (2.2)	4.1	LF-310KA	10	FIL 000068
5 (3.7)	6.9	LF-320KA	20	FIL 000069
7.5 (5.5)	11.3	LF-350KA	50	FIL 000070
10 (7.5)	13.7	LF-350KA	50	FIL 000070
15 (11)	20.6	LF-350KA x 2P	100	FIL 000070 (x 2)
20 (15)	27.4	LF-350KA x 2P	100	FIL 000070 (x 2)
25 (18.5)	34	LF-350KA x 2P	100	FIL 000070 (x 2)
30 (22) to 100 (75)	41 to 130	Contact your YASKAWA representative		

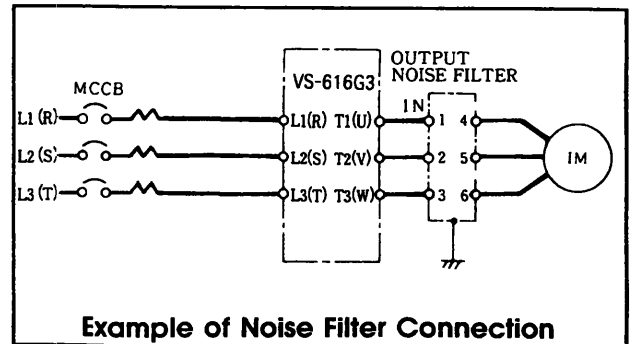

Example of Noise Filter Connection

DIMENSIONS in inch (mm)

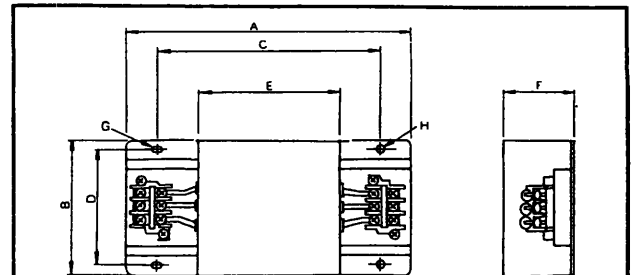

Model	Terminal Plate	A	B	C	D	E	F	G	H	Max lb (kg)
LF-310KA	TE-K5.5 M4	5.51 (140)	3.94 (100)	3.94 (100)	3.54 (90)	2.76 (70)	1.77 (45)	0.28 x Ø0.18 (7 x 4.5)	0.18 (4.5)	1.10 (0.5)
LF-320KA	TE-K5.5 M4	5.51 (140)	3.94 (100)	3.94 (100)	3.54 (90)	2.76 (70)	1.77 (45)	0.28 x Ø0.18 (7 x 4.5)	0.18 (4.5)	1.32 (0.6)
LF-350KA	TE-K22 M6	10.24 (260)	7.09 (180)	7.09 (180)	6.30 (160)	4.72 (120)	2.56 (65)	0.28 x Ø0.18 (7 x 4.5)	0.18 (4.5)	4.41 (2.0)
LF-310KB	TE-K5.5 M4	5.51 (140)	3.94 (100)	3.94 (100)	3.54 (90)	2.76 (70)	1.77 (45)	0.28 x Ø0.18 (7 x 4.5)	0.18 (4.5)	1.10 (0.5)
LF-320KB	TE-K5.5 M4	5.51 (140)	3.94 (100)	3.94 (100)	3.54 (90)	2.76 (70)	1.77 (45)	0.28 x Ø0.18 (7 x 4.5)	0.18 (4.5)	1.32 (0.6)
LF-335KB	TE-K5.5 M4	5.51 (140)	3.94 (100)	3.94 (100)	3.54 (90)	2.76 (70)	1.77 (45)	0.28 x Ø0.18 (7 x 4.5)	0.18 (4.5)	0.9 (0.4)
LF-345KB	TE-K22 M6	10.24 (260)	7.09 (180)	7.09 (180)	6.30 (160)	4.72 (120)	2.56 (65)	0.28 x Ø0.18 (7 x 4.5)	0.18 (4.5)	4.41 (2.0)
LF-375KB	TE-K22 M6	21.26 (540)	12.60 (320)	12.60 (320)	11.81 (300)	13.39 (340)	9.45 (240)	0.35 x Ø0.26 (9 x 6.5)	0.26 (6.5)	26.46 (12.0)
LF-310KB	TE-K60 M8	21.26 (540)	13.28 (340)	13.28 (340)	11.81 (300)	13.39 (340)	9.45 (240)	0.35 x Ø0.26 (9 x 6.5)	0.26 (6.5)	42.99 (19.5)

380 to 460V

Max Applicable Motor Output HP (kW)	Inverter Capacity kVA	Output Noise Filter		
		Model	Rated Current A	Code No
0.5 (0.4)	1.4	LF-310KB	10	FIL 000071
1 (0.75)	2.1	LF-310KB	10	FIL 000071
2 (1.5)	2.7	LF-310KB	10	FIL 000071
3 (2.2)	4.1	LF-310KB	10	FIL 000071
5 (3.7)	6.9	LF-310KB	10	FIL 000071
7.5 (5.5)	10.3	LF-320KB	20	FIL 000072
10 (7.5)	13.7	LF-320KB	20	FIL 000072
10 (7.5)	20.6	LF-335KB	35	FIL 000073
15 (11)	27.4	LF-335KB	35	FIL 000073
25 (18.5)	34	LF-345KB	45	FIL 000074
30 (22)	41	LF-375KB	75	FIL 000075
40 (30)	54	LF-375KB	75	FIL 000075
50 (37)	68	LF-3110KB	110	FIL 000076
60 (45)	82	LF-3110KB	110	FIL 000076
75 (55) to 400 (300)	110 to 510	Contact your YASKAWA representative		

Note: For 500 to 575V, contact your YASKAWA representative.

FREQUENCY METER/AMMETER

MODEL DCF-6A, 1mA—Analog frequency indicating meter is available as an option.

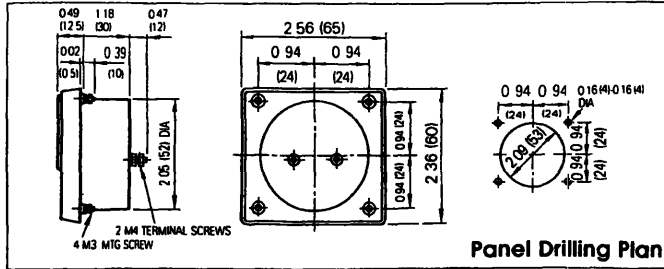
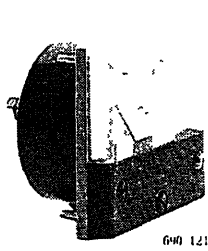

POTENTIOMETER

(Attach to inverter terminal)

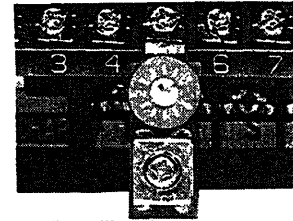

- 2kΩ for frequency command control
- 20kΩ for scale adjusting

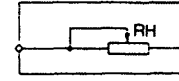

Resistance Value	Code No
2kΩ	ETX002780
20kΩ	ETX002910

FREQUENCY SETTING POTENTIOMETER

MODEL RV30YN 20S, 2kΩ—Adjusts motor frequency by use of frequency setting knob covering the potentiometer.

FREQUENCY METER ADJUSTING POTENTIOMETER

MODEL RV30YN 20S, 20kΩ—Corrects frequency meter reading.

FREQUENCY SETTING KNOB (Type CM-3S)

Used as a means of adjusting frequency setting potentiometer.

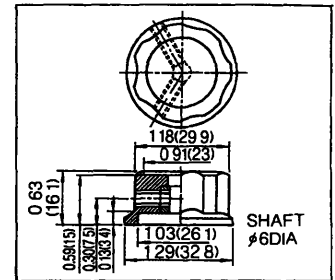
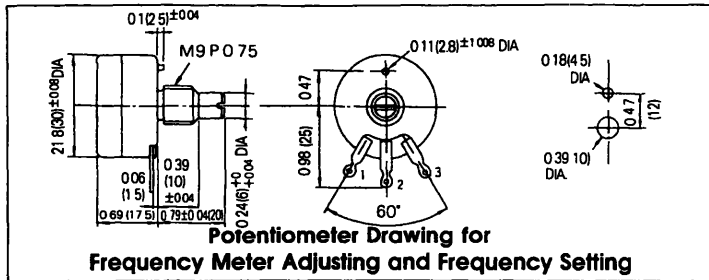
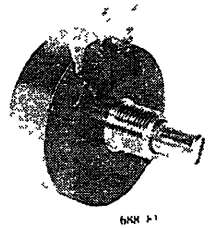

OUTPUT VOLTMETER (Model SCF-12NH Rectification type class 2.5)

200 to 230V: 300V Full-scale (Code No. VM000481)

380 to 460V: 600V Full-scale (Output Voltmeter: Code No. VM000502, Transformer for instrument: Code No. PT000084)

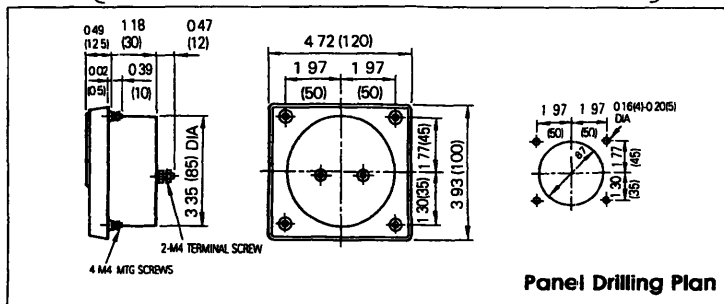
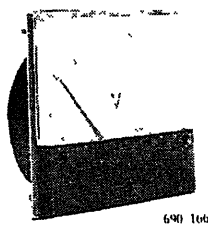

SCALE PLATE (Code No. NPJT41561-1)

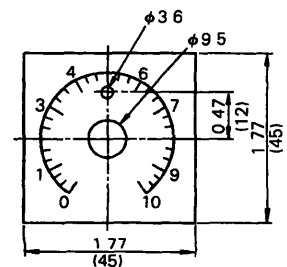

POTENTIAL TRANSFORMER (Model UPN-15B) DIMENSIONS in inch (mm)

15VA 440/110V (400/100V) 50, 60Hz

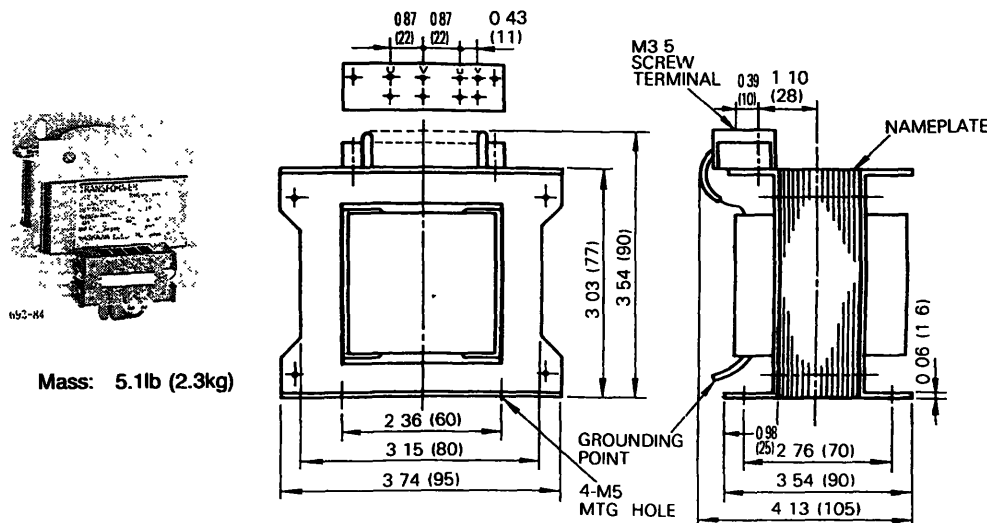

ISOLATOR (Insulation Type DC Transmission Converter)

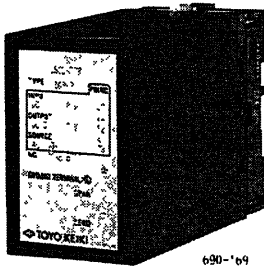

Performance

- | | | | |
|---------------------------------|--|---------------------------|---|
| (1) Allowance | $\pm 0.25\%$ of output span
(Ambient temp 23°C (73°F)) | (5) Output Ripple | With $\pm 0.5\%$ P-P of output span |
| (2) Temperature Influence | With $\pm 0.25\%$ of output span
(The value at $\pm 10^\circ\text{C}$ ($\pm 50^\circ\text{F}$) of ambient temp) | (6) Response Time | 0.5 sec or less (Time to settle to $\pm 1\%$ of final steady value) |
| (3) Aux. Power Supply Influence | With $\pm 0.1\%$ of output span
(The value at $\pm 10\%$ of aux power supply.) | (7) Withstand Voltage | 2000VAC for one min
(between each terminal of input, output, power supply, and enclosure) |
| (4) Load Resistance Influence | With $\pm 0.05\%$ of output span
(In the range of load resistance) | (8) Insulation Resistance | 20M Ω and above (by 500VDC megger)
(between each terminal of input, output, power supply and enclosure) |

Connecting Method

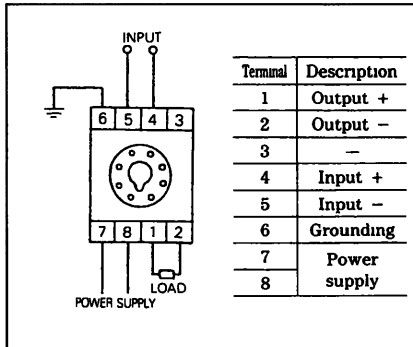

Cable Length

- 4 to 20mA: Within 100m
- 0 to 10V: Within 50m

Product Line

Model	Input Signal	Output Signal	Power Supply	Code No
DGP2-4-4	0 - 10V	0 - 10V	100VAC	CON 000019 25
DGP2-4-8	0 - 10V	4 - 20mA	100VAC	CON 000019 26
DGP2-8-4	4 - 20mA	0 - 10V	100VAC	CON 000019 35
DGP2-3-4	0 - 5V	0 - 10V	100VAC	CON 000019 15
DGP3-4-4	0 - 10V	0 - 10V	200VAC	CON 000020 25
DGP3-4-8	0 - 10V	4 - 20mA	200VAC	CON 000020 26
DGP3-8-4	4 - 20mA	0 - 10V	200VAC	CON 000020 35
DGP3-3-4	0 - 5V	0 - 10V	200VAC	CON 000020 15

Dimensions in inch (mm)

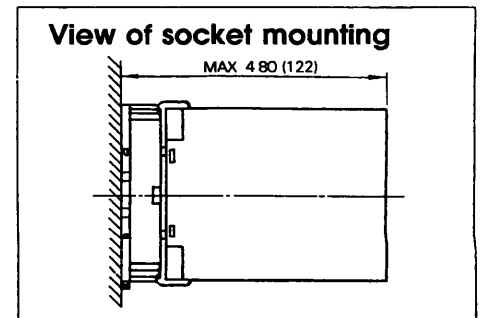
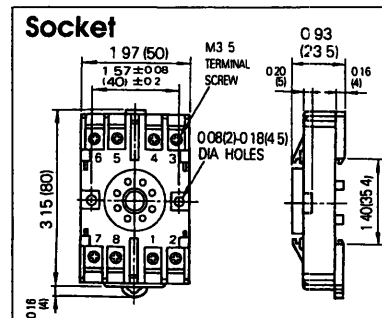
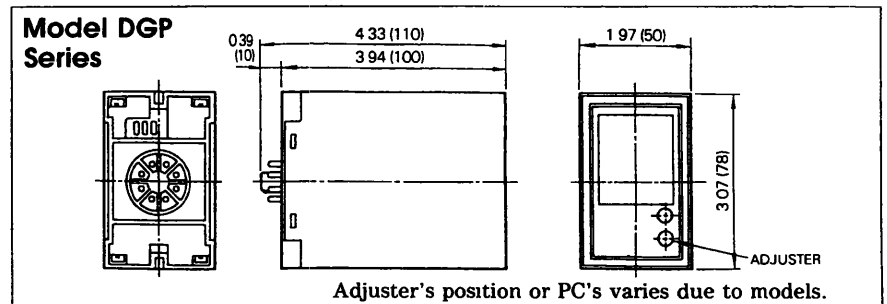

BACKUP CAPACITOR UNIT FOR MOMENTARY POWER LOSS

(Applicable to 0.5 to 3HP(0.4 to 2.2kW) of 200 to 230V or 380 to 460V)

Use this unit for 3HP (2.2kW) and below and to extend the inverters power loss ride-thru ability to 2 seconds.
(Not required above 3HP 2.2kW)

- Connection with Inverter
- Dimensions in inch (mm)

200 to 230V Model P0010
380 to 460V Model P0020

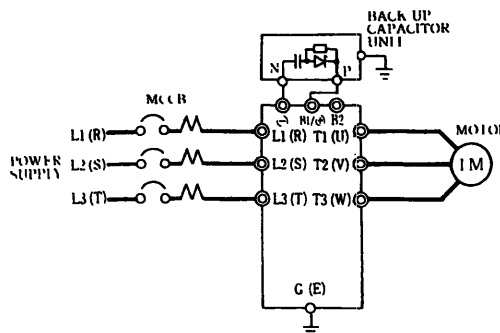



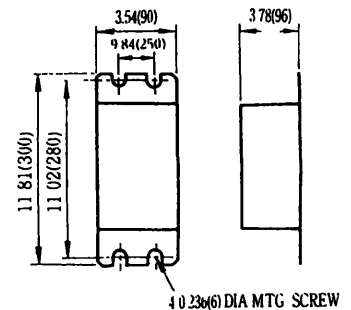





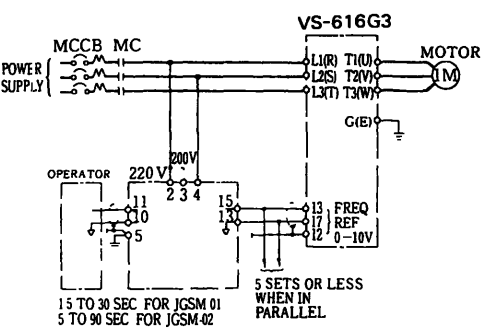

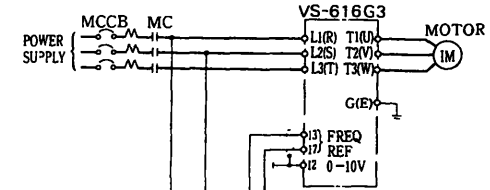

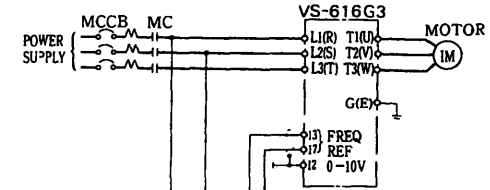
Weight
4.4lb(2kg)

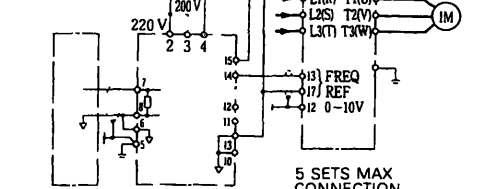

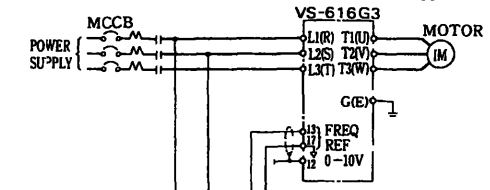



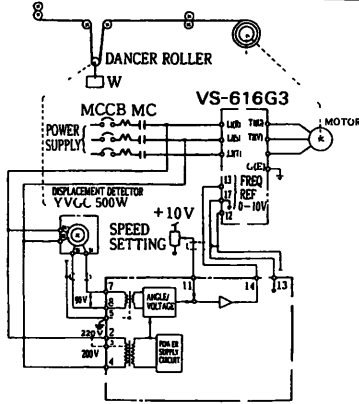
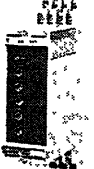
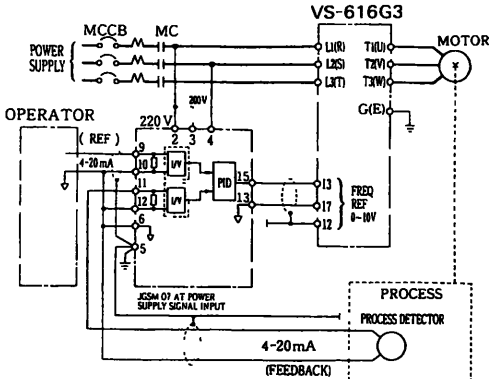

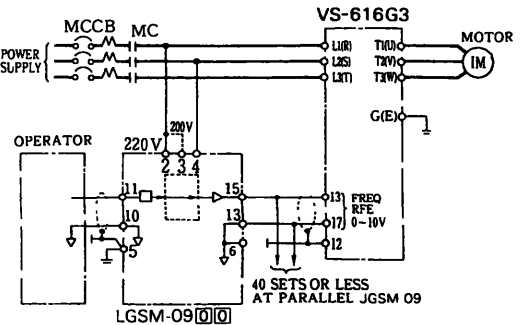
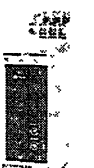
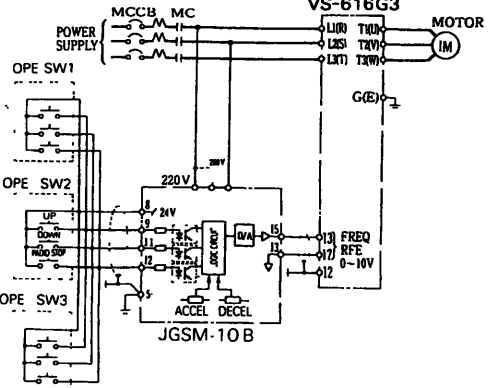
090-02

VS SYSTEM MODULE (Power Supply Capacity: 6VA and below)

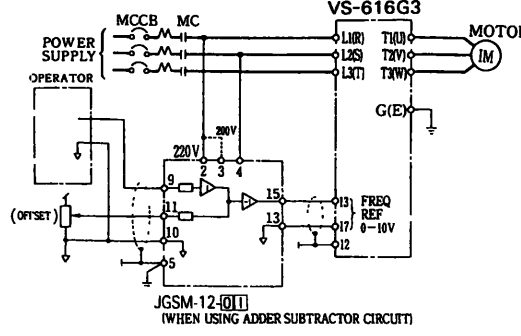
Name (Model)	Configuration	Function	Application
Soft Starter A (JGSM-01) Soft Starter B (JGSM-02)	 689-319	Linear acceleration/deceleration control provides smooth, uniform speed change during starting and stopping and during speed increase and decrease. Accel/decel time adjustable in 1.5 to 30 sec with "A" and 5 to 90 sec with "B".	 <p>VS-616G3</p> <p>MCCB MC POWER SUPPLY (L1(R), L2(S), L3(T)) T1(U), T2(V), T3(W) MOTOR (IM) G(E)</p> <p>OPERATOR 220V 200V 11 10 5 2 3 4 15 14 13 12 11 10 9 8 7 6 5 4 3 2 1</p> <p>15 TO 30 SEC FOR JGSM-01 5 TO 90 SEC FOR JGSM-02</p> <p>5 SETS OR LESS WHEN IN PARALLEL</p>
Ratio Setter A (JGSM-03)	 689-347	Converts the current signal 4 to 20mA of master setter JVOP-03* to voltage signal and sets five types of ratios and biases.	 <p>MCCB MC POWER SUPPLY (L1(R), L2(S), L3(T)) T1(U), T2(V), T3(W) MOTOR (IM) G(E)</p> <p>220V 200V 2 3 4 15 14 13 12 11 10 9 8 7 6 5 4 3 2 1</p> <p>5 SETS OR LESS WHEN IN PARALLEL</p>
Ratio Setter B (JGSM-04)	 689-345	Transforms the frequency signal 0 to 2kHz of master setter JVOP-04* to voltage signal and sets five types of ratios and biases.	 <p>MCCB MC POWER SUPPLY (L1(R), L2(S), L3(T)) T1(U), T2(V), T3(W) MOTOR (IM) G(E)</p> <p>220V 200V 2 3 4 15 14 13 12 11 10 9 8 7 6 5 4 3 2 1</p> <p>5 SETS MAX CONNECTION POSSIBLE</p>
Ratio Setter C (JGSM-17)	 689-314	Transforms master speed signals such as AC voltage signal (200VAC), AC tach-gen signal (30VAC) or DC voltage signal (10VDC) to DC voltage. It can set five types of ratios and biases.	 <p>MCCB MC POWER SUPPLY (L1(R), L2(S), L3(T)) T1(U), T2(V), T3(W) MOTOR (IM) G(E)</p> <p>220V 200V 2 3 4 15 14 13 12 11 10 9 8 7 6 5 4 3 2 1</p> <p>JGSM 03 JGSM 04 JGSM 17</p> <p>5 SETS MAX CONNECTION POSSIBLE</p>
Follower Ratio Setter (JGSM-05)	 689-343	Transforms frequency signal from AC tach-gen to voltage signal and sets five types of ratios and biases.	 <p>MCCB POWER SUPPLY (L1(R), L2(S), L3(T)) T1(U), T2(V), T3(W) MOTOR (IM) G(E)</p> <p>220V 200V 2 3 4 15 14 13 12 11 10 9 8 7 6 5 4 3 2 1</p> <p>JGSM-05</p> <p>5 SETS MAX CONNECTION POSSIBLE</p>

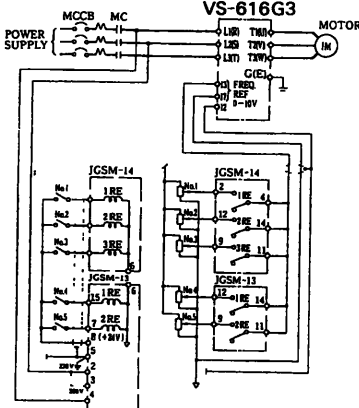
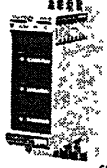
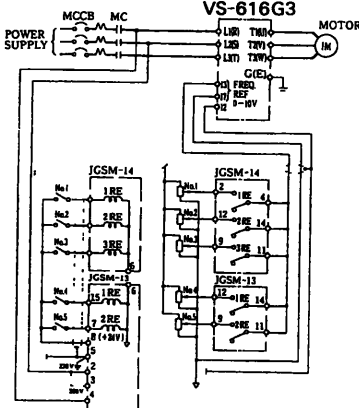
Name (Model)	Configuration	Function	Application
Position Controller (JGSM-06)	 <p>689-155</p>	<p>Synchronizes displacement detector YVGC-500W* in proportion to rotary angle to permit change to DC voltage signal</p> <p>Signal mixing function to take out deviation signal is available</p>	 <p>JGSM-06</p>
PID Controller (JGSM-07)	 <p>689-3E</p>	<p>Independently sets ratio gain, integral and differential time for the simple process control.</p> <p>Integral reset, stepless operation, and wind-up functions are available</p>	 <p>JGSM-07 AT POWER SUPPLY SIGNAL INPUT</p> <p>4-20mA (FEEDBACK)</p>
Preamplifier (JGSM-09+)	 <p>689-150</p>	<p>Amplifies both the power of DC input signal and output of snap-in function modules JZSP-11 to 16* when inserted.</p>	 <p>40 SETS OR LESS AT PARALLEL JGSM 09</p> <p>LJGSM-09</p>
UP/DOWN Setter (JGSM-10B)	 <p>689-333</p>	<p>Executes "UP" or "DOWN" command from remote control type VS operator model JVOP-10* by lowering or raising reference voltage.</p>	 <p>JGSM-10B</p>

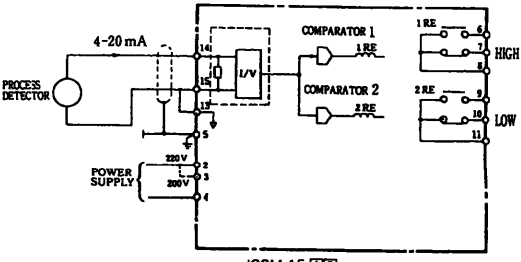
VS SYSTEM MODULE (Power Supply Capacity: 6VA and below) (Cont'd)

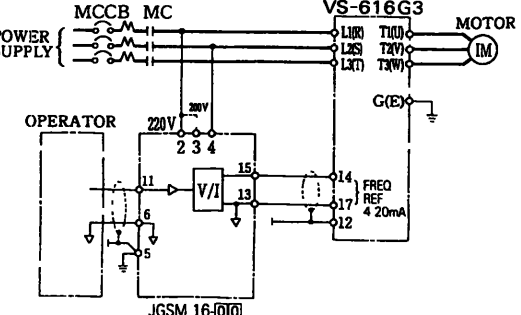
Name (Model)	Configuration	Function	Application
Operational Amplifier (JGSM-12†□□)	 689-327	Required operational circuits are provided through a range of operational impedances.	 VS-616G3 JGSM-12-011 (WHEN USING ADDER SUBTRACTOR CIRCUIT)
Signal Selector A (JGSM-13)	 689-329	Consists of power supply circuit and two relay circuits. Used as a selector circuit of control signals.	 VS-616G3 JGSM-14 JGSM-13
Signal Selector B (JGSM-14)	 689-341	Contains three relay circuits. Used as a selector circuit of control signals. Power supply from model JGSM-13.	 VS-616G3 JGSM-14 JGSM-13
Comparator (JGSM-15†□□)	 689-335	Compares DC voltage, current, AC tach-gen, frequency, or reference signals with two preset levels. It drives relays and output contact signal (1NO, NC contact)	 JGSM-15-113 (WHEN USING I/V CONVERTER)
V/I Converter (JGSM-16†□□)	 689-337	Converts DC voltage input signal to current signal of 4 to 20mA which can be connected to instrument. Insertion of snap-in module can determine input signals such as frequency or tach-gen.	 VS-616G3 JGSM-16-010

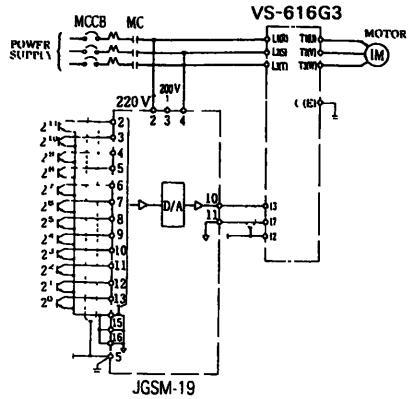
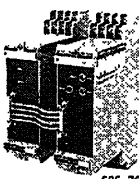
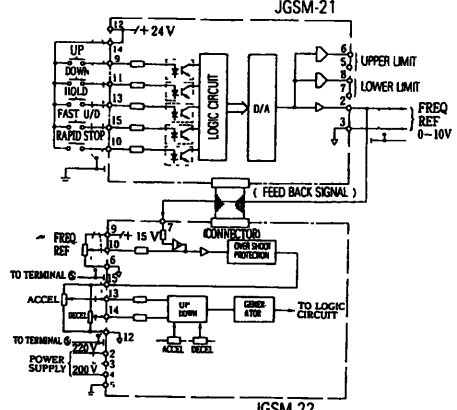
Name (Model)	Configuration	Function	Application
D/A Converter (JGSM-18) (JGSM-19)	 689-387	Converts BCD 3-digit or 12 bits binary digital signals to 0 to $\pm 10V$ analog signals with high accuracy. Model JGSM-18: BCD 3-digit input type Model JGSM-19: 12 bits binary type	 VS-616G3 JGSM-19
Static Potentiometer (JGSM-21) (D/A Converter) (JGSM-22) (Controller)	 686-76	In addition to the functions of model JGSM-10B (remote setting device), wide application is offered through the command value maintenance function at power failure, the variable acceleration/deceleration function that allows external setting times, and the analog tracking function. The two system modules must always be used together to configure the static potentiometer.	 JGSM-21 JGSM-22

* Available as Yaskawa standard.

†  Shows model of VS snap-in function modules.

‡  Indicates model of impedance.

Both 200/220V at 50Hz and at 60Hz are available as standard. Use a transformer for other power supplies.

■ VS Snap in Module List

Application	Name	Model
Short-circuit of mounting connector of VS snap in module	Short-circuit PC board	JZSP-00
Buffer accel/decel operation	Soft starter	JZSP-12
Operation by signal of either process adjusting meter or VS operator JVOP-03.	I/V converter	JZSP-13
Operation by signal of VS operator JVOP-04	F/V converter	JZSP-14
Sequence operation with main unit	Tach-gene follower	JZSP-15
Adding/subtracting operation of each signal	Signal mixer	JZSP-16□□
		JZSP-16-01
		JZSP-16-02
		JZSP-16-03

■ VS System Module Dimensions in inch (mm)

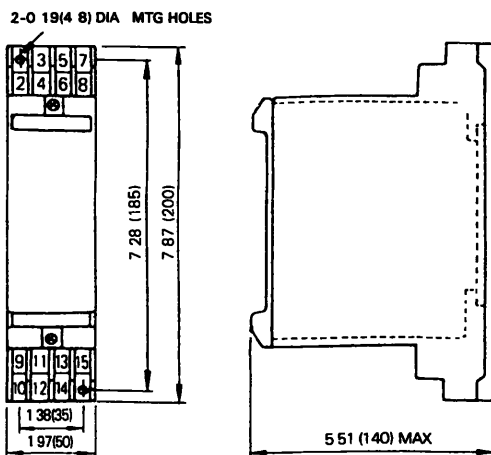

Approx Weight 1.8lb (0.8kg)

NOTES ON APPLICATION OF MOTORS

Application to Existing Standard Motors

A standard motor driven by the inverter generates slightly less power than it does when it is driven with commercial power supply.

Also, the cooling effect deteriorates in low speed range so that the motor temperature rise increases. Reduce load torque in the low speed range. Allowable load characteristics of the standard motor are shown in the figure. If 100% continuous torque is required in the low speed range, use an inverter duty motor. (See page 93.)

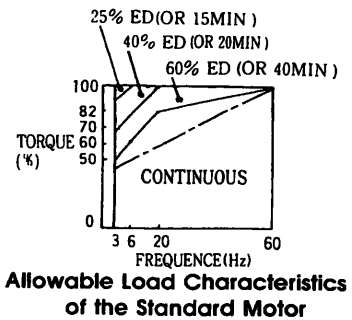

■ High speed operation

When the motor is used above 60Hz, motor mechanical design should be verified. Contact your motor mfg.

■ Torque characteristics

Motor torque characteristics vary when the motor is driven by an inverter instead of commercial power supply. Check the load torque characteristics of the machine to be connected. (For torque characteristics for inverter operation, see page 93.)

■ Vibrations

Because of the high carrier modulation technique for PWM control, the VS-616G3 series reduces motor vibration to a level equal to running with a commercial power supply. Larger vibrations may occur under the following conditions:

- (1) Response at resonant frequency of the mechanical system.
Special care is required if a machine which has previously been driven at a constant speed, is to be driven at varying speeds. Installation of anti-vibration rubber padding under the motor base and frequency jump control are recommended.
- (2) Rotator residual imbalance
Special care is required for operation at 60 Hz or higher frequencies.

■ Noise

Inverter operation is as quiet as operation with commercial power supply. At above rated speed (60 Hz), noise may increase by motor cooling fan.

Application to Special Purpose Motors

Motors with Brakes	Use brake-equipped motors with an independent power supply. Connect the brake power supply to the inverter primary side. When the brake operates (the motor stops) it turns the inverter output OFF. Some types of brakes may make abnormal sounds in low speed range.
Pole Change Motors	Select the inverter with a capacity exceeding the rated current of each pole. Pole change should be made only after the motor stops. If a pole is changed while the motor is rotating, the regenerative overvoltage or overcurrent protection circuit is activated and the motor coasts to a stop.
Submersible Motors	Since the rated current of underwater motors is large compared with general purpose motors, select an inverter with a larger capacity. If the wire length between the inverter and the motor is large, use cables with sufficiently large diameter.
Explosion-proof Motors	Explosion-proof motors which are applied to an inverter must be currently approved as explosion-proof equipment. The inverter is not explosion-proof and should not be located where explosive gases exist.
Geared Motors	Lubrication method and continuous rotation limit differ with manufacturers. When oil lubrication is employed, continuous operation only in low speed range may cause burnout. Before operating the motor at more than 60Hz you should consult the motor manufacturer.
Single-phase Motors	Single-phase motors are not suitable for variable speed operation with an inverter. If the inverter is applied to a motor using a capacitor stack, a high harmonic current flows and the capacitor may be damaged. For split-phase start motors and repulsion start motors, the internal centrifugal switch will not be actuated and the starting coil may be burned out. Therefore, use only 3-phase motors.

Power Transmission Mechanism (Gear Reduction, Belt, Chain, etc.)

When gear boxes and change/reduction gears lubricated with oil are used in power transmission systems, continuous low speed operation decreases the oil lubrication function. Also, operation at more than 60Hz may result in noise, reduced life, etc.

MOTOR OUTPUT TORQUE CHARACTERISTICS

Application example with 20HP (15 kW), 4-pole motor and CIMR-G3□2015 inverter

The output torque of an induction motor driven by the inverter depends on the motor type. Select a motor according to the driven machine's load requirements.

Examples of Standard Motor Combination Characteristics

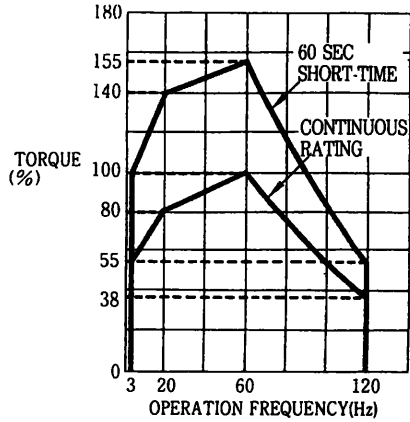

Base Frequency 60 Hz
(V/f for 60Hz, 220V Input Voltage)

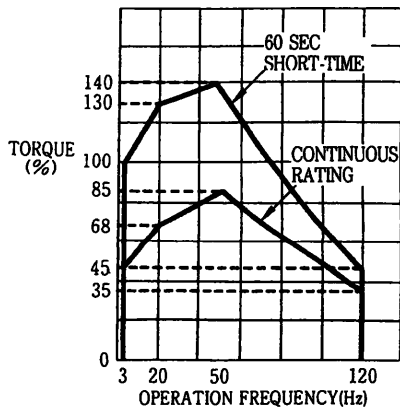

Base Frequency 50 Hz
(V/f for 60Hz, 200V Input Voltage)

Examples of Inverter Duty Motor Characteristics

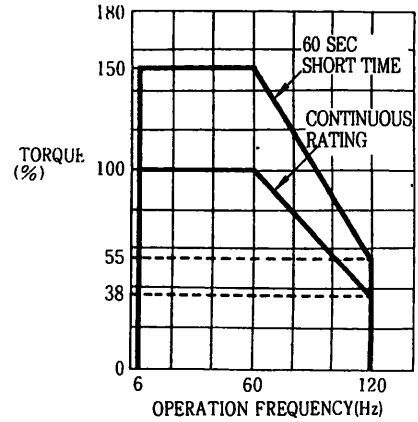

Base Frequency 60 Hz
(V/f for 60Hz, 220V Input Voltage)

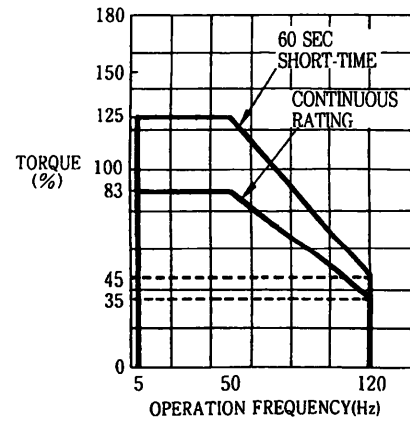

Base Frequency 50 Hz
(V/f for 60Hz, 200V Input Voltage)

Motor Protection with Electronics Thermal Overload

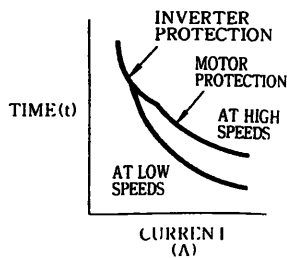

Motor thermal characteristics as a function of operating frequency are simulated to protect the motor at any speed.

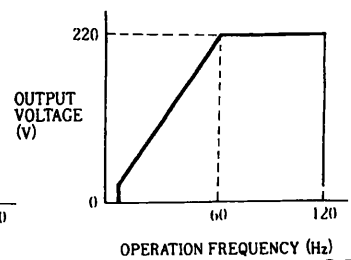
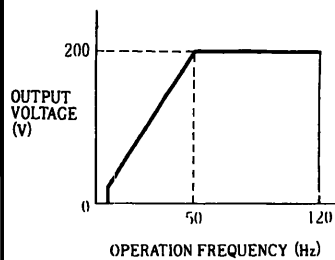

• Standard V/f Characteristics (for 50Hz) (for 60Hz)



STANDARD INTERCONNECTION DIAGRAM

- Notes: 1  indicates shielded leads and  twisted-pair shielded leads
- 2 External terminal ⑮ of +15V has maximum output current capacity of 20mA
3. Either external terminal ⑬ or ⑭ can be used
4. Terminal symbols: ● shows main circuit; ○ shows control circuit

With Digital Operator

System Constant Setting
(Standard Setting at Factory Shipment)

System Constant NO	Data			
	4th digit	3rd digit	2nd digit	1st digit
5n-04	-	-	i	i

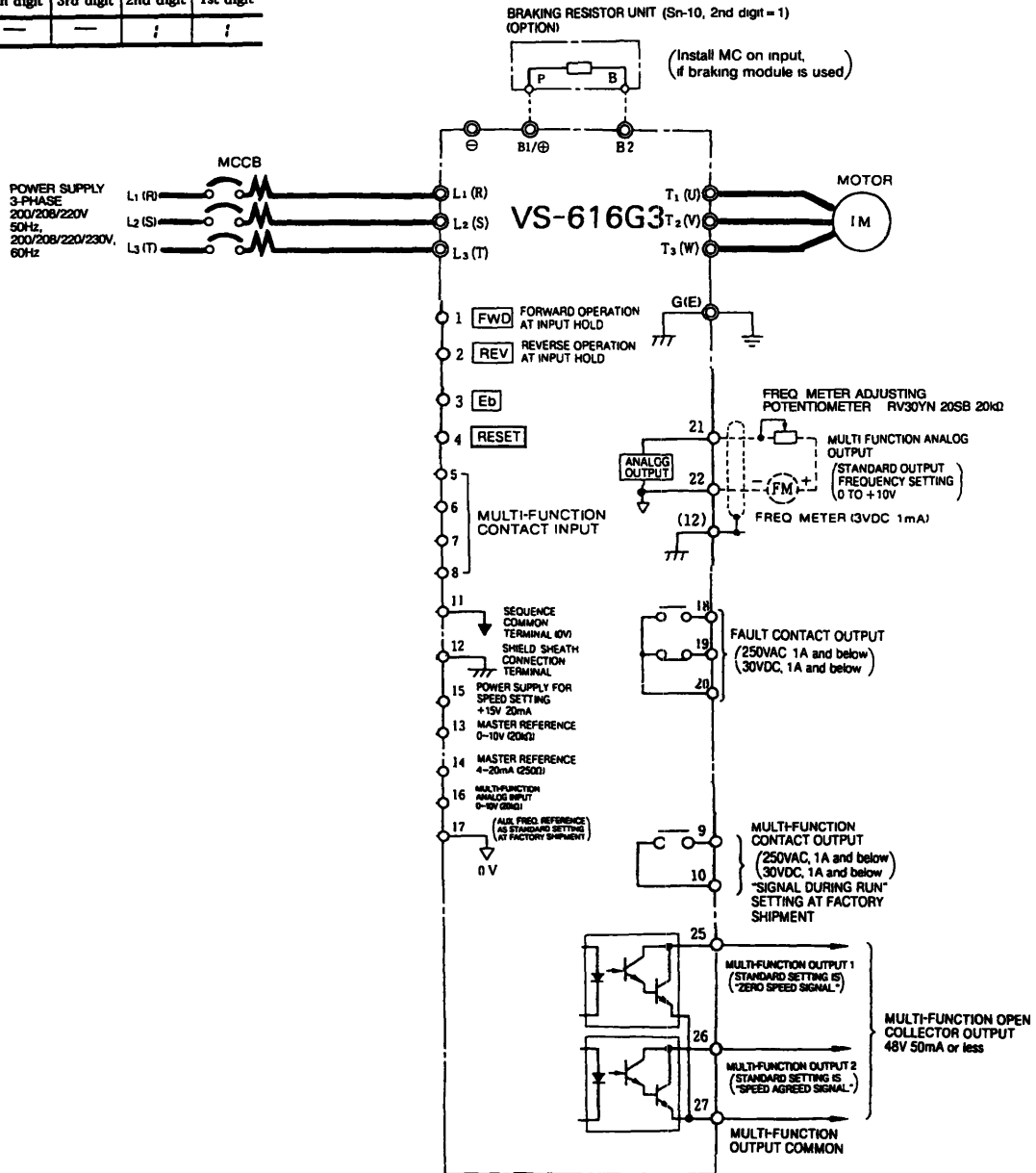

5. The multi-function output is for the exclusive use of indicators, and is not for the control system (e.g. feedback control) For the control system, mount an optional analog monitor card (AO-08 or AO-12)
6. The inverters of max. applicable motor output 200V 40HP (30kW) or more and 400V 75HP (55kW) or more have a control power input and a cooling fan power input (l_1-l_2). For details, see page 64.

With Transistor (Open Collector) Operation

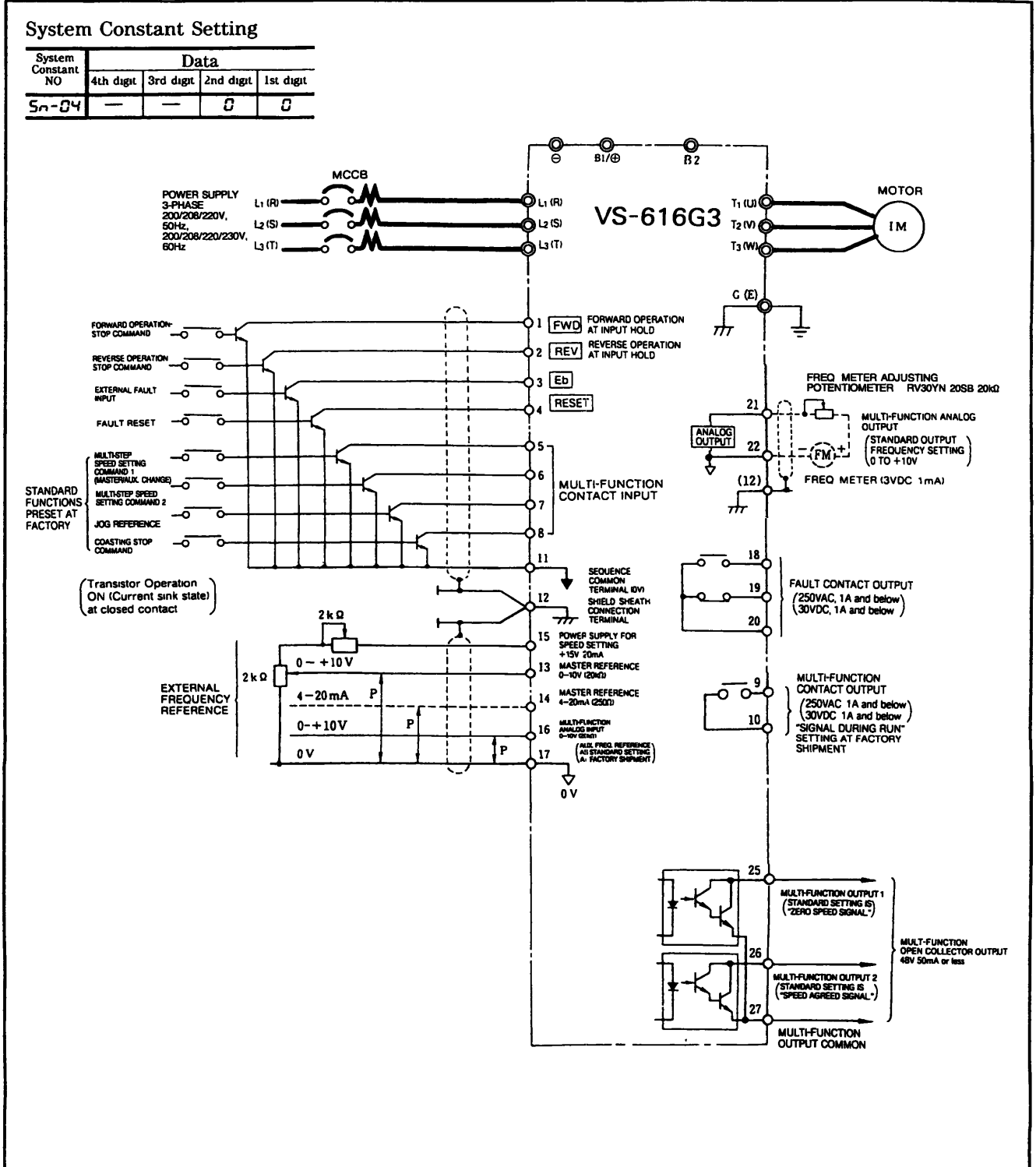

With Contact Output, Open Collector Output

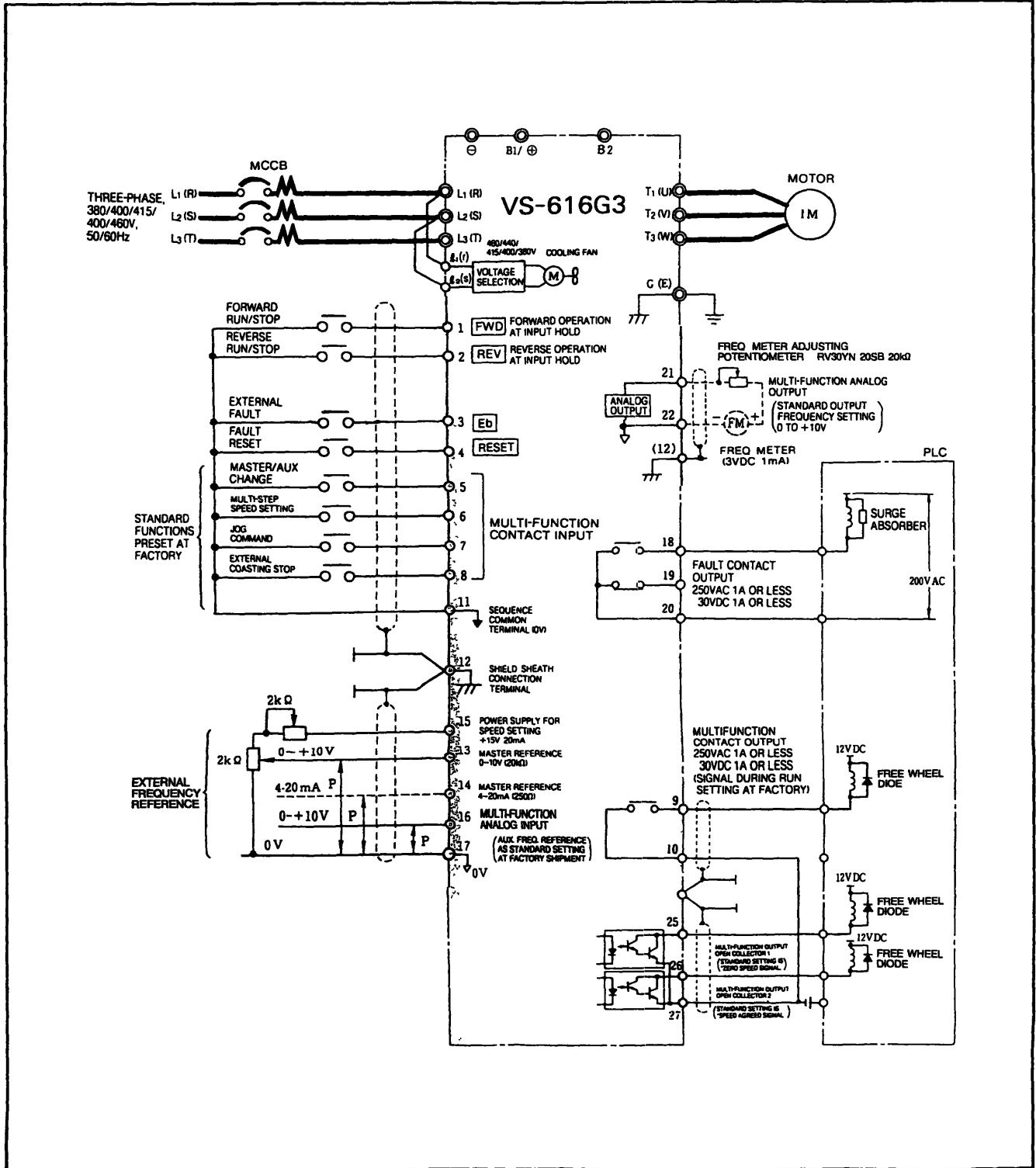

Backup Capacitor for Momentary Power Loss (200V class—4.1kVA and below) (400V class—4.1kVA and below)

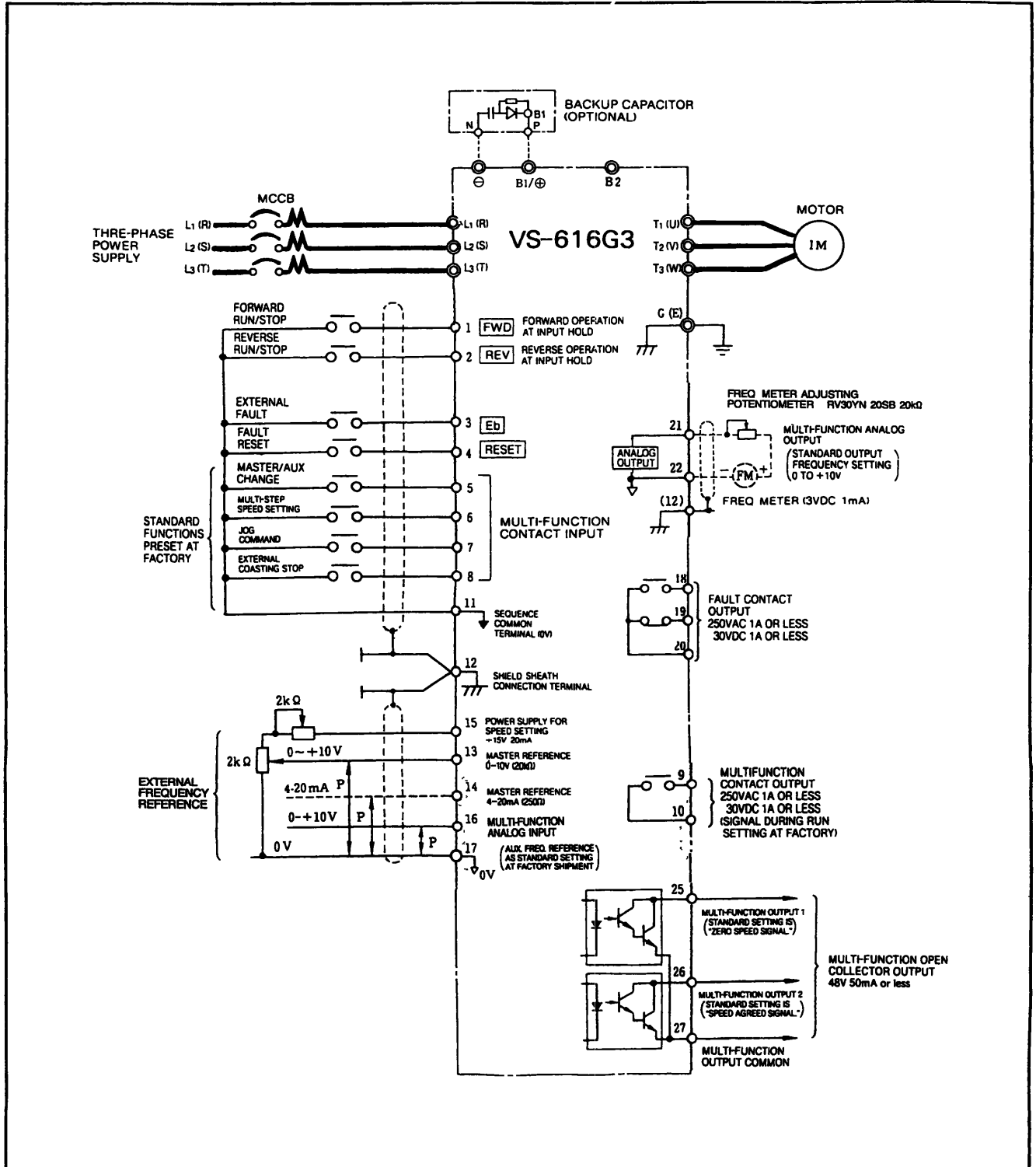

With VS Operator Models JVOP - 95 □, - 96 □

System Constant Setting

System Constant No	Data			
	4th digit	3rd digit	2nd digit	1st digit
Sn-04	—	—	0	0
Sn-05	0	—	0	—
Sn-15	—	—	0	3
Sn-19	—	—	0	0
Sn-20	—	—	0	0

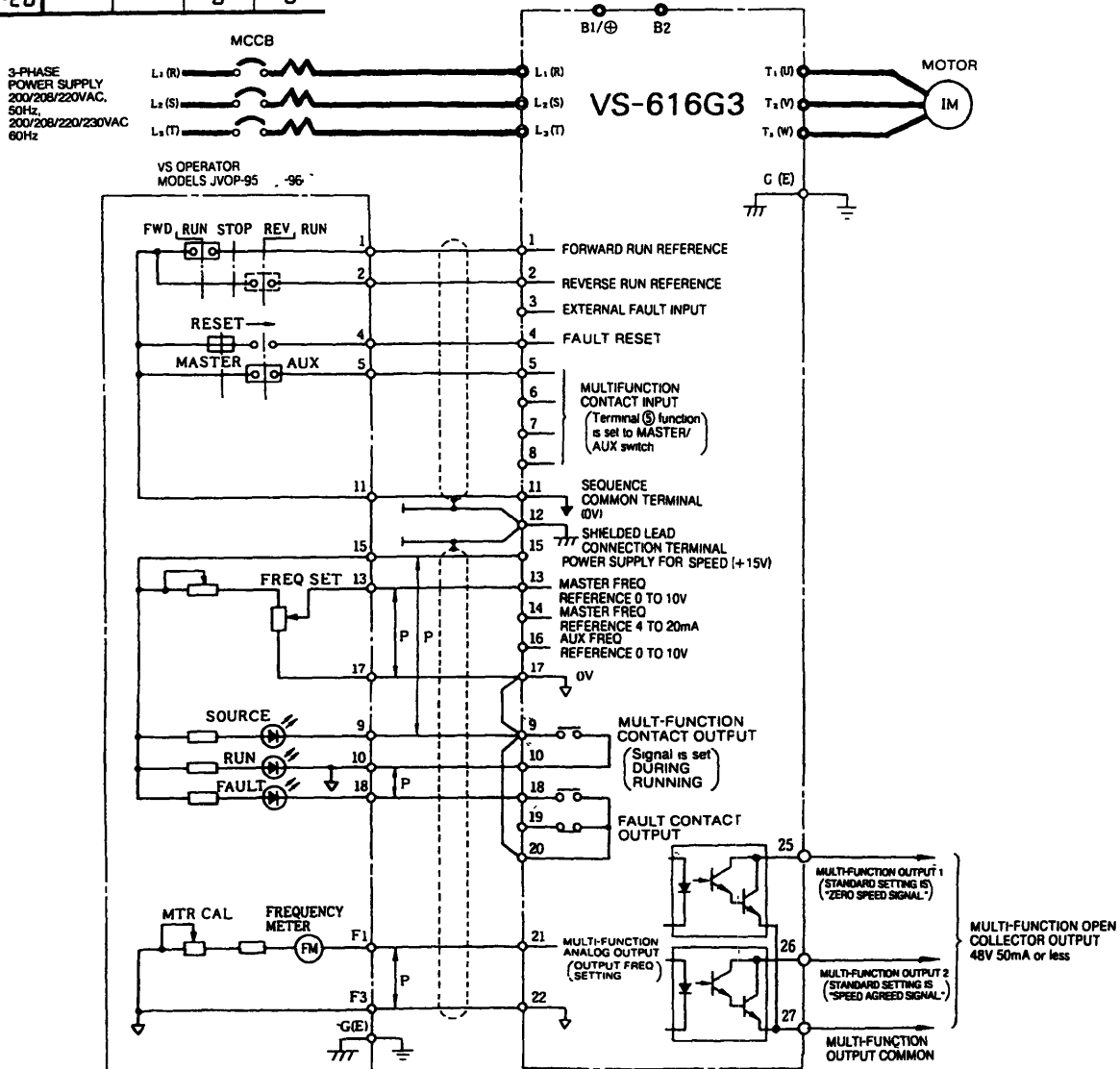

With Power Supply Magnetic Contactor (MC)

System Constant Setting

System Constant NO	Data			
	4th digit	3rd digit	2nd digit	1st digit
5n-34	—	;	0	0*

* Frequency reference selection
 0: Set by frequency setting resistor
 1: Set value of digital operator
 (An-01)

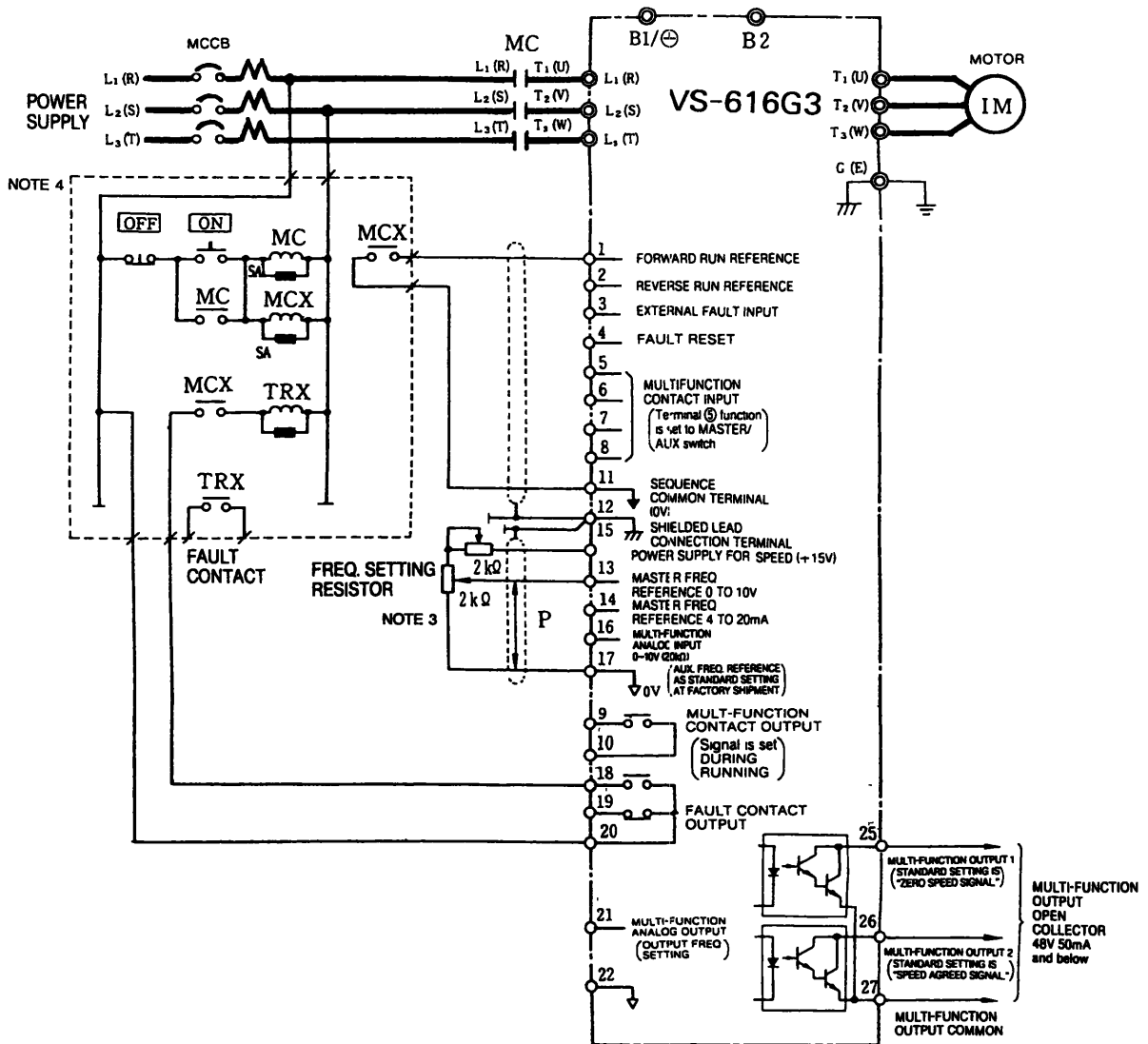

- Notes
- 1 Braking is not activated at deceleration stop. It coasts to a stop.
 - 2 Use MC or MCX of delay release type for restart operation after momentary power loss.
 - 3 Frequency setting resistor is not required for the use of digital operator's set value as frequency reference.
 - 4 Turn off the switch after motor completely stops.

With Braking Resistor Unit

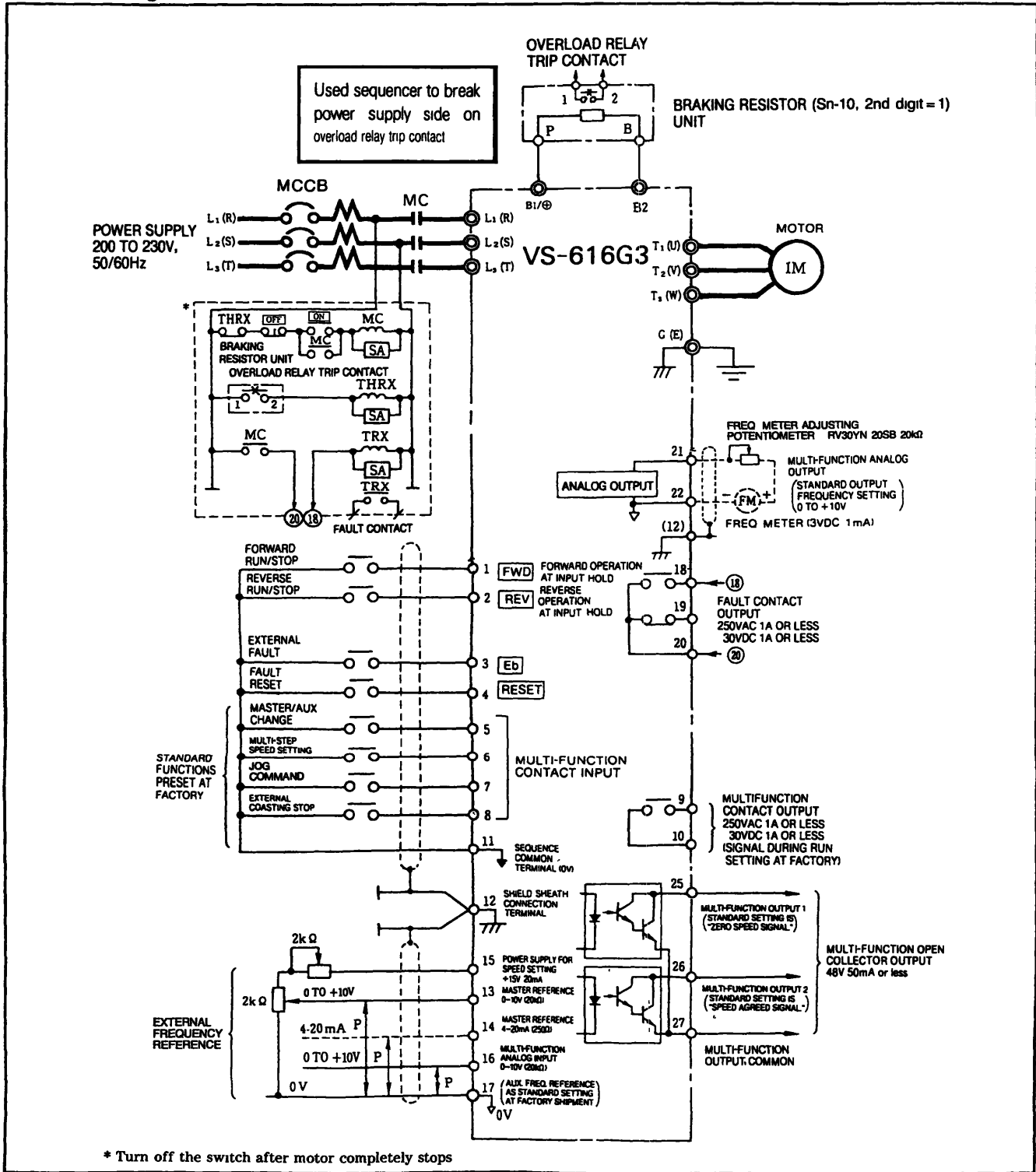

With Isolator

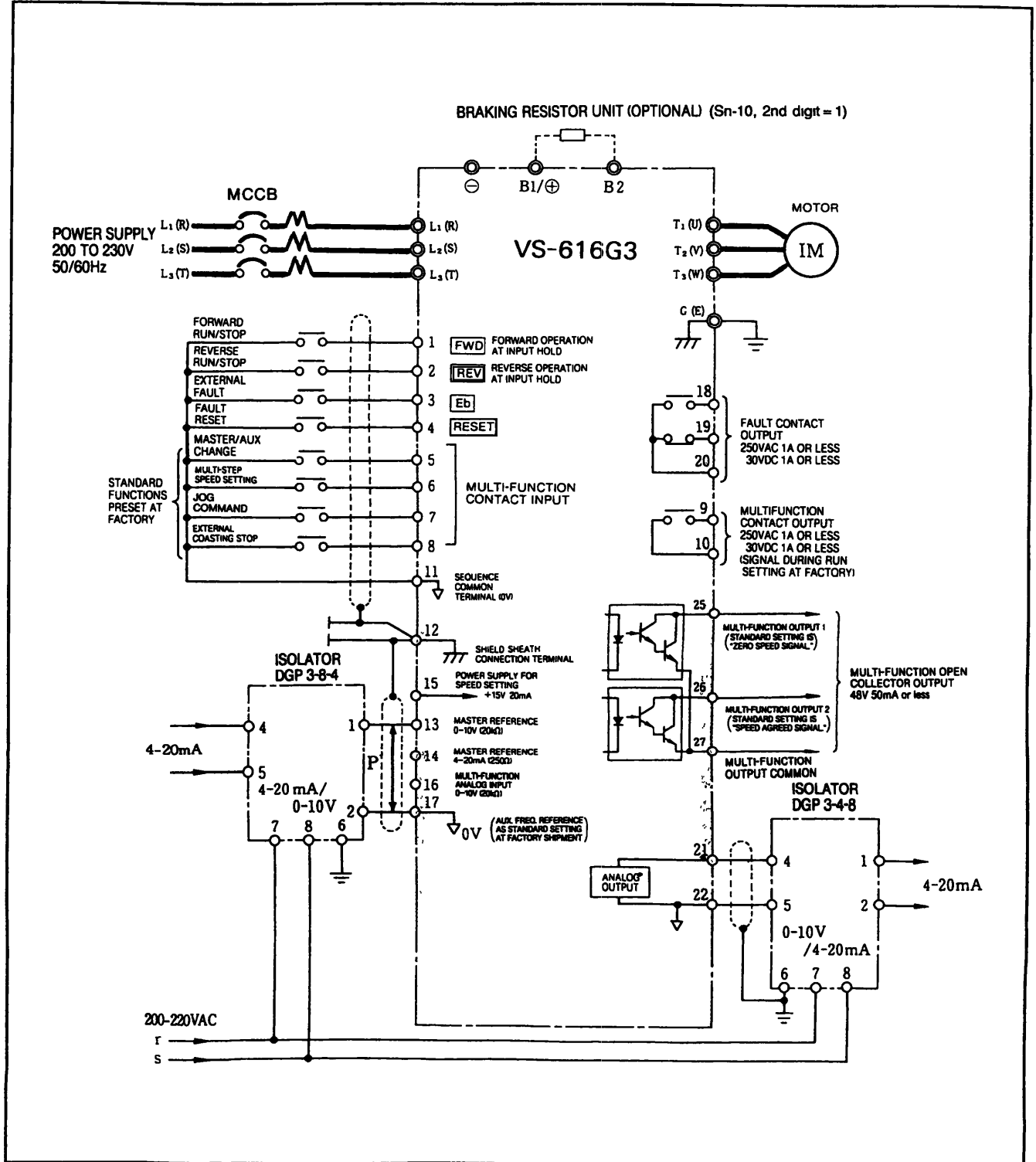

APPLICATIONS

FANS AND BLOWERS (CONTRIBUTES TO ENERGY-SAVING AND OPERATION)

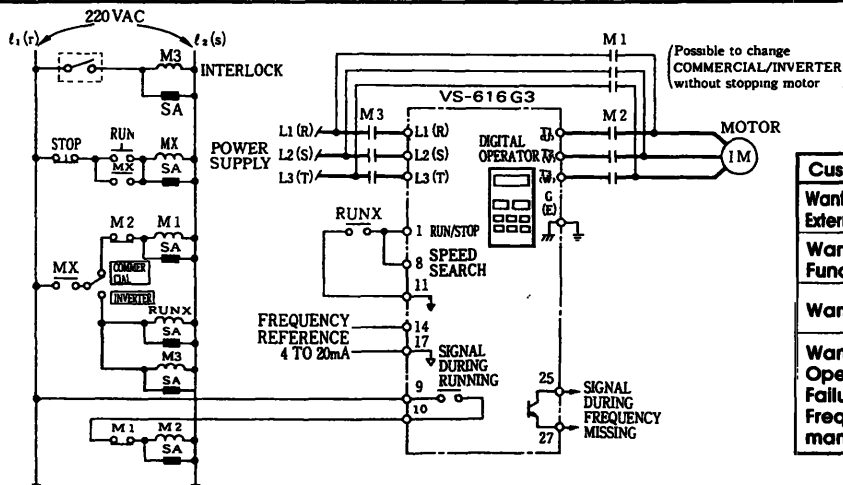
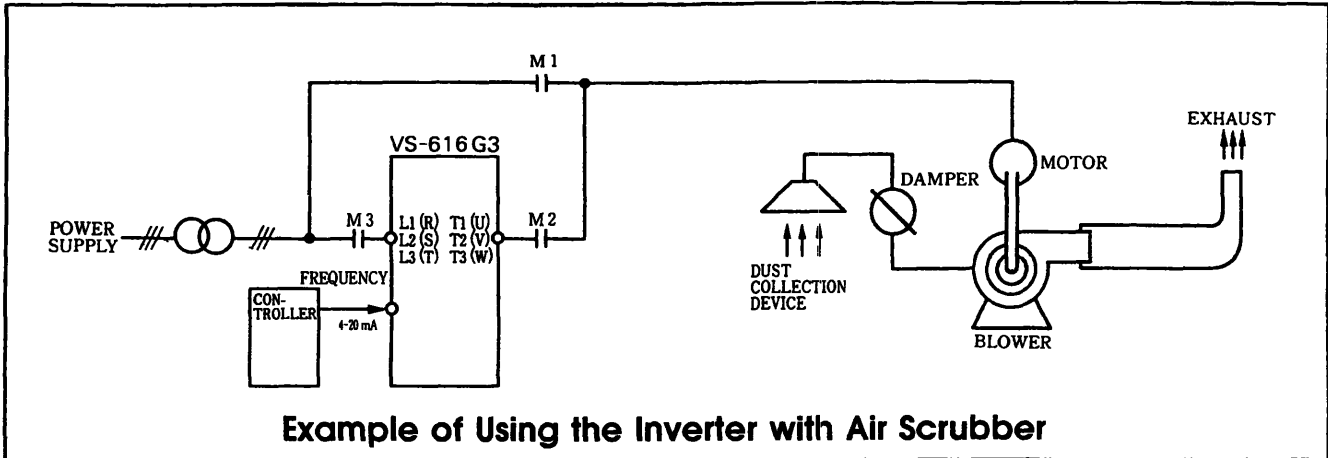

Customer's Request	Function and Parameter Setting
Wants to Operate Using External Terminals	Operation signal selection Sn-04 = x x 00
Wants Speed Search Function	Multi-function input Sn-15 to Sn-18 = 61
Wants Coast to Stop	Stop procedure selection Sn-04 = 01 x x
Wants to Continue Operation even if Failure Occurs in Frequency Commanding Equipment.	Automatic continuous operation mode when command is missing Sn-04 = 1 x x x Command-missing signal Sn-20 to Sn-22 = 0C

Details of the Commercial/Inverter Selector Circuit

Application example	Customer's Request	Applicable VS-616G3 Function	Function and Parameter Setting
Dust-collecting blower, fan for boilers Fan for cooling towers	Wants to switch commercial power supply and inverter drive without stopping the motor.	Use the speed search operation	Multi-function input Sn-15 to Sn-18 = 61 or 62
	Needs inverter start from coasting stop status. Is it possible without stopping the motor?		
	Wants to save energy since the load is not heavy at low-speed operation	Apply the variable load V/f	V/f selection Sn-02 = 05
	Wants to avoid overload tripping	Apply the stall prevention function during-running	During-operation stall level change Cn-30 = 30 to 200%
	Wants to continue operation even when momentary power loss not longer than 2 seconds occurs.	Select the instantaneous outage reset and restart mode	Momentary power loss protection Sn-11 = x 1 x x
	Wants to continue operation even if a failure occurs in higher-order frequency commanding equipment.	Select the automatic continuous operation mode when frequency command is missing	Operating signal selection when frequency command is missing Sn-06 = 1 x x x, Sn-20 to 22 = 0C
	Wants to monitor output power.	Turn the monitor to the output power indication	Monitor display Un-06
	Needs r/min lower limit for lubricating the decelerator bearing	Use the frequency command lower limit	Frequency command lower limit Cn-15 = 0 to 109%
	Wants to avoid mechanical resonance (The resonance point will be passed, and continuous operation is eliminated at this point.)	Use the preset frequency band prohibition function (frequency jump control). Up to 3 frequencies prohibited.	Preset prohibited frequency Cn-16 to 18 = 0 to 400Hz Preset prohibited frequency range Cn-19 = 0 to 25.5Hz
	Wants to prevent machine stop caused by inverter tripping	Use the retry function	Retry count Cn-36 = 0 to 10 times

PUMP (STABILITY MAKES AUTOMATIC CONTROL EASY)

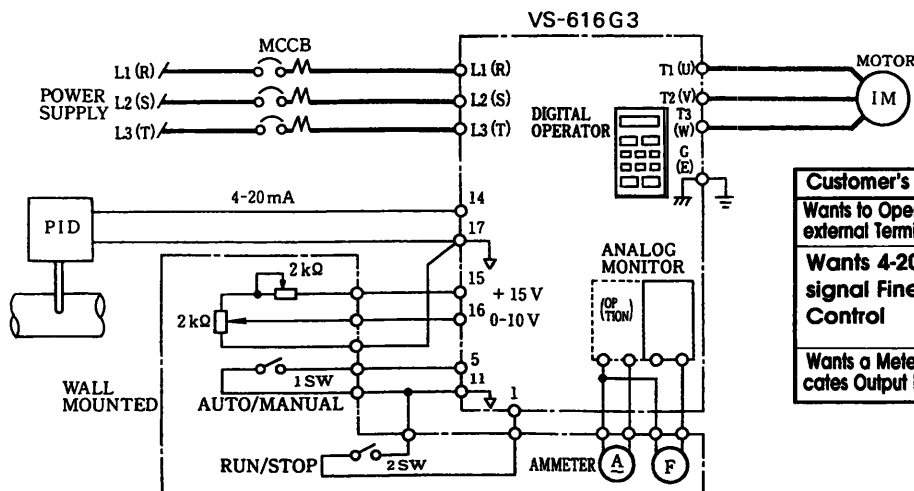
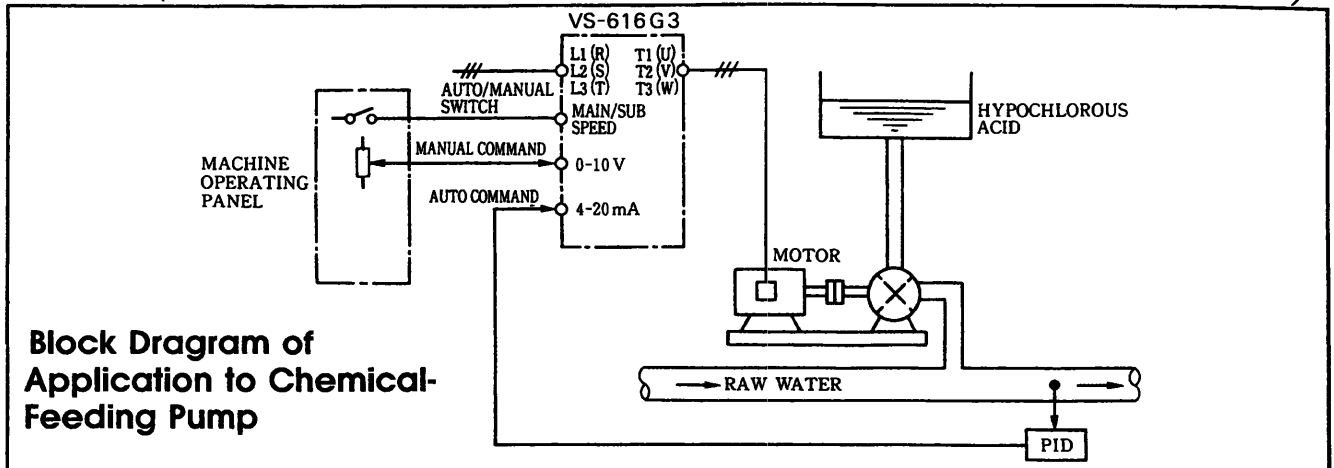

Customer's Request	Function and Parameter Setting
Wants to Operate Using external Terminals	Operation signal selection Sn-04 = x x 00
Wants 4-20mA signal Fine Control	Frequency command gain bn-05 = 0% to 100% Frequency command bias bn-06 = -100% to 100%
Wants a Meter that Indicates Output Frequency	Channel 1 output Sn-28 = x x 00 Channel 2 output Sn-28 = 01 x x

Manual/Auto Switch Circuit

Application	Customer's Request	Applicable VS-616G3 Function	Function and Parameter Setting
Chemical-Feeding Pump	Wants to save energy since the load is not heavy at low-speed operation	Use torque compensation function Bn-07 = 1 0 Increment up/down in units of 0.1 and check current.	Motor rated slip · bn-08 = 0 to 9.9%, Motor rated current · Cn-09 = 10 to 200A Motor no-load current Cn-34 = 0 to 99%, Slip correction primary lag time : Cn-35 = 0 to 25 5s
	Wants to have Manual/Auto switching function.	Use the Master/Aux. switching function Two toggle switches do the job	Master/Aux. switching Sn-15 to 18 = 03
	Needs an ammeter for monitoring load conditions	Use an F-I motor (option)	Output selection function Sn-28 = x x 00
Warm/Cold Water Circulation Pump	Wants to drive the pump directly using 4-20mA signal	Use external terminals (14) and (17)	Run signal selection Sn-04 = x x 00
	Wants a function which can maintain minimum speed.	Use the lower-limit of the reference frequency	Frequency reference lower limit Cn-15 = 0 to 109%
	Wants to run the system using the commercial power supply when an emergency occurs, then return to inverter	Use a selector circuit together with the speed search function to restart turning motor	Speed search function selection Sn-15 to 18 = 61 or 62
	Wants a function which can keep the system working without resetting it even when a momentary power loss occurs	Use the continuous operation function which can compensate for a momentary power loss within two seconds Use a toggle switch for selecting the start and stop of operations	Momentary power loss protection Sn-11 = x 1 x x
Discharge Pump	Wants to keep a constant water level inside a tank using a water gauge	Read signals directly sent from the water-level adjusting unit (4 to 20 mA)	Run signal selection Sn-04 = x x 00
	Wants to keep the motor rpm above the minimum because if the rpm is too low, water flows in the reverse direction	Use the lower-limit of the frequency reference	Frequency ref lower limit Cn-15 = 0 to 109%

CONVEYOR AND LIFTER (Improves Safety and Enables Optimum Operation Setting)

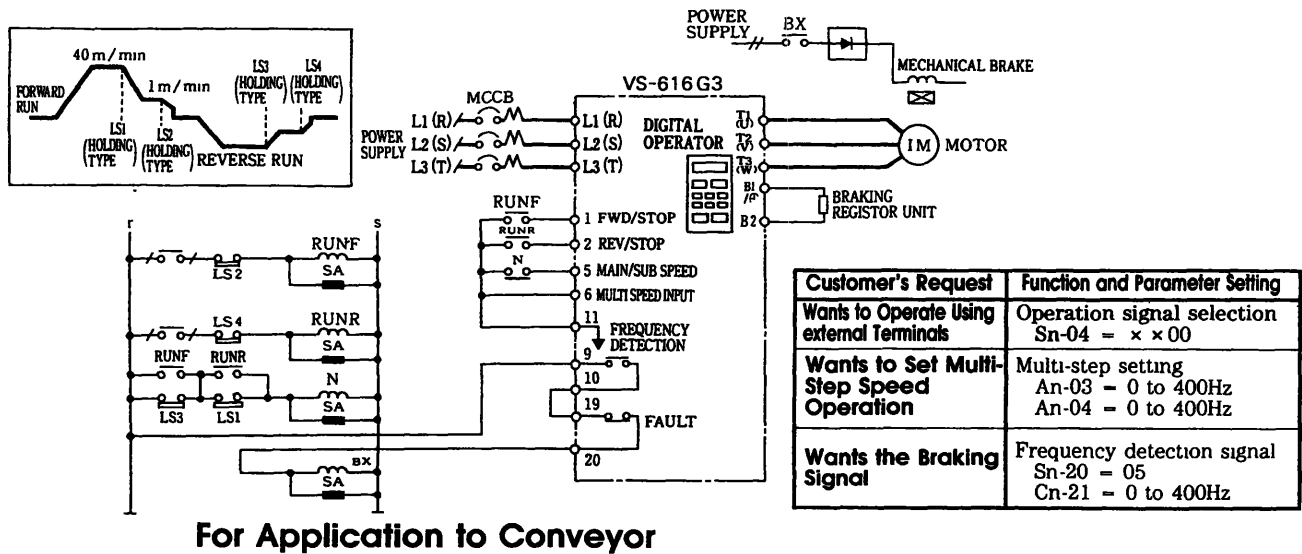
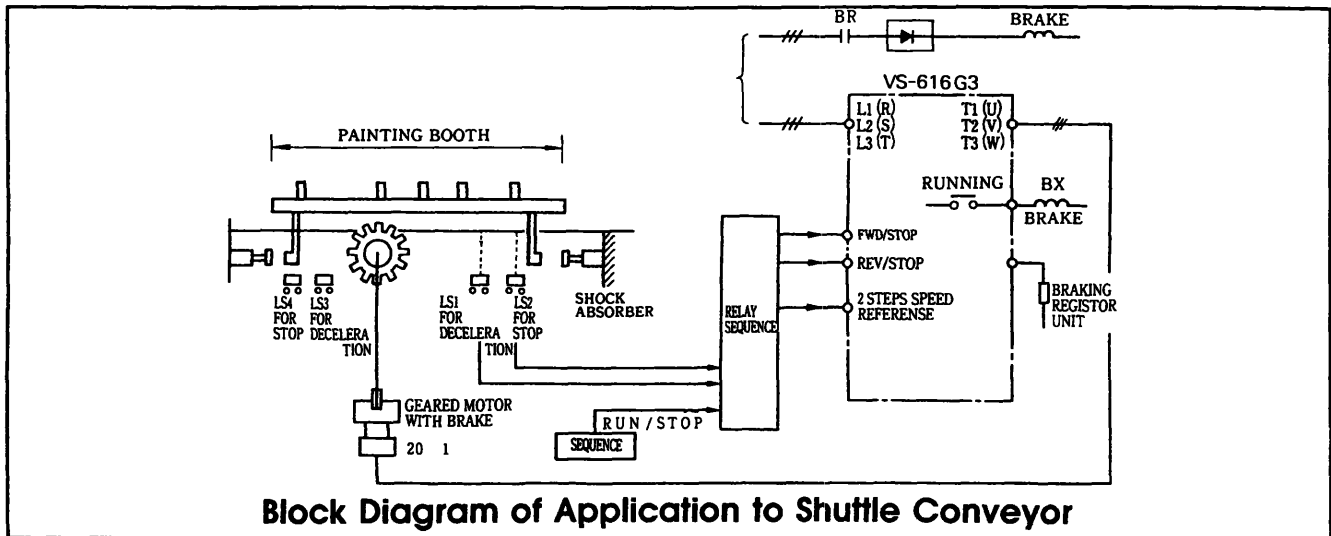

Application	Customer's Request	Applicable VS-616G3 Function	Function and Parameter Setting
Shuffle Conveyor	Wants to increase precision of positioning stop.	Control the braking motor using contact output from terminals 9 and 10. Run at lower speeds.	Operating signal selection Slip prevention Sn-04 = x x 0 x, Sn-20 = 05, Cn-21 = 0 to 400Hz Torque compensation gain bn-07 = 0 to 9.9
	Wants to perform two-step speed operation	Use the multi-step speed function.	Multi-step operation An-01 to 04 = 0 to 400Hz
	Wants smooth accel/decel time	Apply non-linear accel/decel	Operating signal selection Sn-06 = x x □ □ selection
	Wants to vary accel/decel time.	Use the accel/decel time setting function.	Accel/decel time switching Sn-15 to 18 = 07
	Wants to select stop procedure according to degree of emergency	Select stop procedures.	External fault Sn-15 to 18 = 20 to 5F
Raw Material Input Conveyor	Wants to increase starting torque (with a constant-torque motor).	Use the standard-equipped automatic torque boosting function.	Torque compensation gain bn-07 = 0 to 9.9
Steel Pipe Conveyor	Wants to drive more than one motor with a single inverter.	The function is provided.	—
Lifter	Wants a simple slip compensation function	Check the motor generation torque by the excess torque detection function.	Over torque detection Sn-07 = x x x 1 Over torque detection level Cn-26 = 30 to 200% Over torque detection time Cn-27 = 0 to 25.5S
	Wants to use the non-excitation operating type braking motor.	Use the free V/f setting function to turn the motor without excess excitation.	V/f selection Sn-02 = 0F Free V/f setting Cn-02 to 08 = Setting

LATH (Improves Accel/Decel Speed Performance)

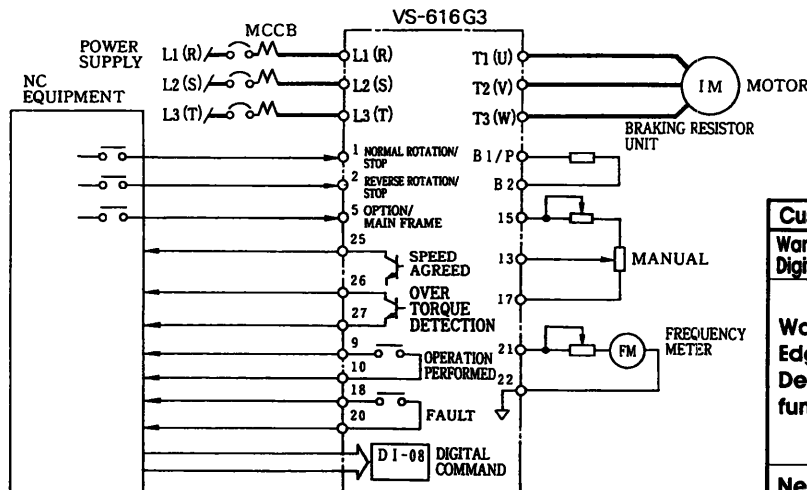
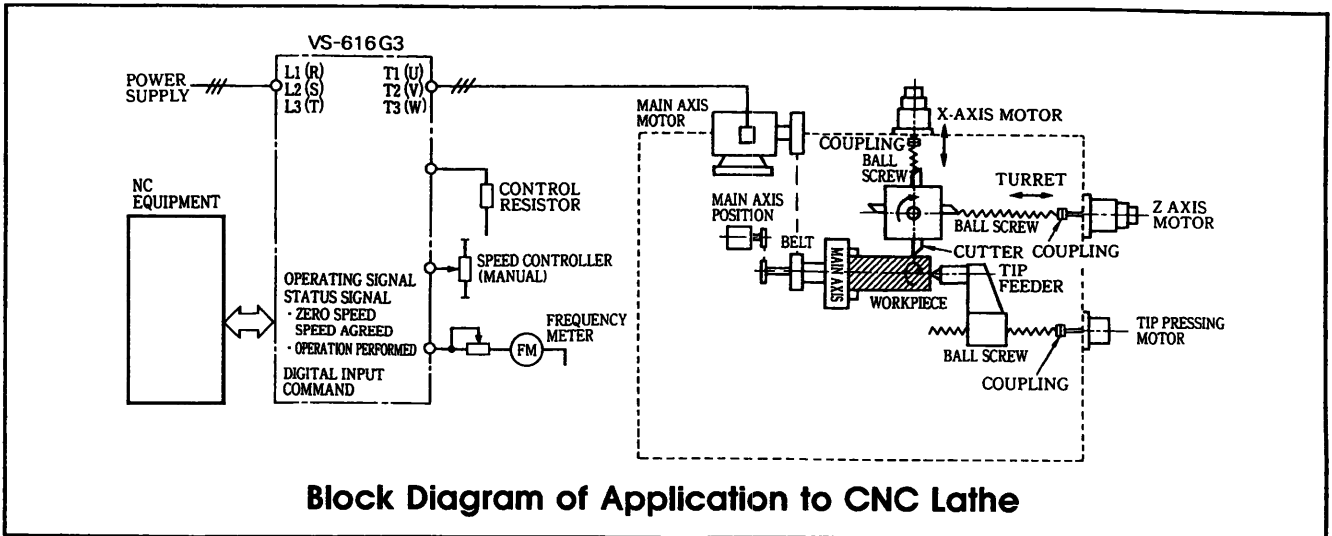

Interface Circuit to NC

Customer's Request	Function and Parameter Setting
Wants to Operate Using Digital Command.	DI-08 (option)
Wants a Cutter Edge Abrasion Detection function.	Over torque detection Sn-07 = × × × 1 Over torque detection level Cn-26 = 30% to 200% Over torque detection time Cn-27 = 0 to 25.5 seconds Multi-function output Sn-20 to Sn-22 = 0B
Needs a Speed Agreed Signal	Frequency agreed signal Sn-20 to Sn-22 = 02

Application	Customer's Request	Applicable VS-616G3 Function	Function and Parameter Setting
CNC Lathe	Needs a large constant-output range.	Use the winding selection motor	Option
	Wants the cutting loss detection function.	Apply the over torque detection function.	Over torque detection Sn-07 = 0001 Over torque detection level Cn-26 = 30% to 200% Over torque detection time Cn-27 = 0 to 25.5 seconds Multi-function output Sn-20 to Sn-22 = 0B
	Wants to turn motor with digital input	Use the digital speed command equipment	Connect DI-08. Frequency command setting mode Sn-26 = select
	Wants to interface to NC.	Apply the zero-speed function.	Multi-function output Sn-20 to Sn-22 = 01
		Apply the speed agreed function.	Multi-function output Sn-20 to Sn-22 = 02
Super High-precision Lathe	Wants to reduce vibration	Apply the over torque detection function (Cutting loss)	Multi-function output Sn-20 to Sn-22 = 0B
		Apply the energy-saving mode.	Energy-saving operation Sn-15 to Sn-18 = 63 bn-9 = 0% to 200%

Inverter Capacity Selection

Inverter Capacity Check Points

Classification	Item		Related specification			
			Speed and Torque Characteristics	Time ratings	Overload Capacity	Starting torque
Load characteristics	Load type	Friction load and weight load Liquid (viscous) load Inertia load Load with power transmission and accumulation	○			○
	Load speed and torque characteristics	Constant torque Constant output Decreasing torque	○		○	
	Load characteristics	Motoring Braking or overhauling load Constant load Shock load Repetitive load High-start torque Low-start torque	○	○	○	○
Operation	Continuous operation Long-time operation at medium or low speeds Short-time operation			○	○	
Rated output	Maximum required output (instantaneous) Constant output (continuous)		○		○	
Rated r/min	Maximum r/min Rated r/min		○			
Power supply	Power supply transformer capacity percentage impedance Voltage fluctuations Number of phases, single phase protection Frequency				○	○
Deterioration of load capacity due to age	Mechanical friction, losses in wiring Duty cycle modification			○		○

Inverter Capacity Required for Continuous Operation

Item	Calculation formula
Required output for the load within the allowable range ?	$\frac{k \times P_M}{\eta \times \cos \phi} \leq \text{Inverter capacity [kVA]}$
Motor capacity within the inverter ratings ?	$k \times \sqrt{3} \times V_M \times I_M \times 10^{-3} \leq \text{Inverter capacity [kVA]}$
Current within the inverter ratings ?	$k \times I_M \leq \text{Inverter capacity [A]}$

Inverter Capacity Required for Group Drive

Item	Calculation formula with overload capacity of 150% for 1 minute	
	Motor acceleration of 1 minute or less	Motor acceleration of 1 minute or more
Starting requirements are within the inverter capacity ?	$\frac{k \times P_M}{\eta \times \cos \phi} \{ n_T + n_s (k_s - 1) \}$ $= P_{CI} \left\{ 1 + \frac{n_s}{n_T} (k_s - 1) \right\}$ $\leq 1.5 \times \text{Inverter capacity [kVA]}$	$\frac{k \times P_M}{\eta \times \cos \phi} \{ n_T + n_s (k_s - 1) \}$ $= P_{CI} \left\{ 1 + \frac{n_s}{n_T} (k_s \times 1) \right\}$ $\leq \text{Inverter capacity [kVA]}$
Current within the inverter capacity ?	$n_T \times I_M \left\{ 1 + \frac{n_s}{n_T} (k_s - 1) \right\}$ $\leq 1.5 \times \text{Inverter capacity [A]}$	$n_T \times I_M \left\{ 1 + \frac{n_s}{n_T} (k_s - 1) \right\}$ $\leq \text{Inverter capacity [kVA]}$

Symbols

P_M , Motor shaft output required for the load [kW]
 η , Motor efficiency (normally, approx. 0.85)
 $\cos \phi$, Motor power factor (normally, approx. 0.8)
 V_M , Motor voltage [V]
 I_M , Motor current [A]
 (current with commercial power supply)
 k , Correction factor calculated from current distortion factor (1.05 to 1.1, depending on the PWM method)
 P_{CI} , Continuous capacity [kVA]
 k_s , Motor starting current/motor rated current
 n_T , Number of motors in parallel
 n_s , Number of simultaneously started motors
 (GD^2) , Total (GD^2) reflected into motor shaft (kg m^2)
 T_L , Load torque (N m)
 t_A , Motor acceleration time
 J , Total (GD^2) reflected into motor shaft (kg m^2)

Inverter Capacity Required for Starting

Item	Calculation formula [$t_A < 60s$]
Total starting capacity within the inverter capacity ?	$\frac{k \times N}{973 \times \eta \times \cos \phi} \left(\frac{T_L}{9.8} + \frac{4J}{375 \times t_A} \right) \leq 1.5 \times \text{Inverter capacity [kVA]}$

FORMULA for Calculating Motor Capacity

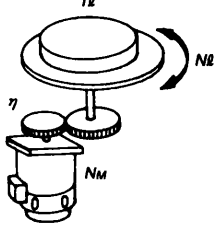
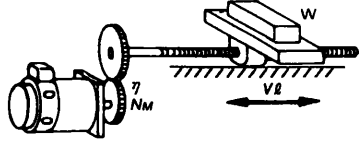
	<p>Rotary motion</p> 	<p>Linear motion (Horizontal motion)</p> 		
<p>in HP lb·ft</p>	<ul style="list-style-type: none"> • $P_o = \frac{T_l \cdot N_l}{5250 \cdot \eta}$ [HP] • $P_a = \frac{W K L^2 \cdot (N_l)^2}{1620 \times 10^3 \cdot t_a}$ [HP] • $T_L = \frac{N_l}{N_M \cdot \eta} \cdot T_l$ [lb·ft] • $W K L^2 = \left(\frac{N_l}{N_M}\right)^2 \cdot W K L^2$ [lb·ft²] • $t_a = \frac{(W K M^2 + W K L^2) \cdot N_M}{308 (\alpha \cdot T_M - T_L)}$ [sec] • $t_d = \frac{(W K M^2 + W K L^2) \cdot N_M}{308 (\beta \cdot T_M + T_L)}$ [sec] 	<ul style="list-style-type: none"> • $P_o = \frac{\mu \cdot W \cdot V_l}{33000 \cdot \eta}$ [HP] • $P_a = \frac{W \cdot (V_l)^2}{64 \times 10^6 \cdot t_a}$ [HP] • $T_L = \frac{\mu \cdot W \cdot V_l}{2\pi \cdot N_M \cdot \eta}$ [lb·ft] • $W K L^2 = \frac{1}{4} W \left(\frac{V_l}{\pi \cdot N_M}\right)^2$ [lb·ft²] • $t_a = \frac{(W K M^2 + W K L^2) \cdot N_M}{308 (\alpha \cdot T_M - T_L)}$ [sec] • $t_d = \frac{(W K M^2 + W K L^2) \cdot N_M}{308 (\beta \cdot T_M + T_L)}$ [sec] 		
	<p>Legend:</p> <table style="width: 100%; border: none;"> <tr> <td style="width: 50%; vertical-align: top;"> <ul style="list-style-type: none"> P_o : Running power [HP] P_a : Required power for accel [HP] N_l : Load speed [rpm] N_M : Motor shaft speed [rpm] V_l : Load velocity of load [ft/min.] η : Machine efficiency μ : Friction factor W : Weight of load [lb] $W K M^2$: Motor inertia [lb·ft²] $W K L^2$: Load inertia [lb·ft²] $W K L^2$: Load inertia [lb·ft²] (Reflected to shaft) </td> <td style="width: 50%; vertical-align: top;"> <ul style="list-style-type: none"> T_l : Load torque [lb·ft] T_L : Load torque [lb·ft] (Reflected to shaft) T_M : Motor rated torque [lb·ft] t_a : Acceleration time [sec] t_d : Deceleration time [sec] α : 0.8 – 1.2 β : 0.1 – 0.2 (200V class) 0.05 – 0.1 (400V class) </td> </tr> </table>		<ul style="list-style-type: none"> P_o : Running power [HP] P_a : Required power for accel [HP] N_l : Load speed [rpm] N_M : Motor shaft speed [rpm] V_l : Load velocity of load [ft/min.] η : Machine efficiency μ : Friction factor W : Weight of load [lb] $W K M^2$: Motor inertia [lb·ft²] $W K L^2$: Load inertia [lb·ft²] $W K L^2$: Load inertia [lb·ft²] (Reflected to shaft) 	<ul style="list-style-type: none"> T_l : Load torque [lb·ft] T_L : Load torque [lb·ft] (Reflected to shaft) T_M : Motor rated torque [lb·ft] t_a : Acceleration time [sec] t_d : Deceleration time [sec] α : 0.8 – 1.2 β : 0.1 – 0.2 (200V class) 0.05 – 0.1 (400V class)
<ul style="list-style-type: none"> P_o : Running power [HP] P_a : Required power for accel [HP] N_l : Load speed [rpm] N_M : Motor shaft speed [rpm] V_l : Load velocity of load [ft/min.] η : Machine efficiency μ : Friction factor W : Weight of load [lb] $W K M^2$: Motor inertia [lb·ft²] $W K L^2$: Load inertia [lb·ft²] $W K L^2$: Load inertia [lb·ft²] (Reflected to shaft) 	<ul style="list-style-type: none"> T_l : Load torque [lb·ft] T_L : Load torque [lb·ft] (Reflected to shaft) T_M : Motor rated torque [lb·ft] t_a : Acceleration time [sec] t_d : Deceleration time [sec] α : 0.8 – 1.2 β : 0.1 – 0.2 (200V class) 0.05 – 0.1 (400V class) 			
<p>in kW kg·m</p> <p>(Conventional Unit)</p>	<ul style="list-style-type: none"> • $P_o = \frac{T_l \cdot N_l}{973 \cdot \eta}$ [kW] • $P_a = \frac{G D L^2 \cdot (N_l)^2}{365 \times 10^3 \cdot t_a}$ [kW] • $T_L = \frac{N_l}{N_M \cdot \eta} \cdot T_l$ [kg·m] • $G D^2 L = \left(\frac{N_l}{N_M}\right)^2 \cdot G D^2 L$ [kg·m²] • $t_a = \frac{(G D^2 M + G D^2 L) \cdot N_M}{375 (T_M \cdot \alpha - T_L)}$ [sec] • $t_d = \frac{(G D^2 M + G D^2 L) \cdot N_M}{375 (T_M \cdot \beta + T_L)}$ [sec] 	<ul style="list-style-type: none"> • $P_o = \frac{\mu \cdot W \cdot V_l}{6120 \cdot \eta}$ [kW] • $P_a = \frac{W \cdot (V_l)^2}{3600 \times 10^3 \cdot t_a}$ [kW] • $T_L = \frac{\mu \cdot W \cdot V_l}{2\pi \cdot N_M \cdot \eta}$ [kg·m] • $G D^2 L = W \left(\frac{V_l}{\pi \cdot N_M}\right)^2$ [kg·m²] • $t_a = \frac{(G D^2 M + G D^2 L) \cdot N_M}{375 (T_M \cdot \alpha - T_L)}$ [sec] • $t_d = \frac{(G D^2 M + G D^2 L) \cdot N_M}{375 (T_M \cdot \beta + T_L)}$ [sec] 		
	<p>Legend:</p> <table style="width: 100%; border: none;"> <tr> <td style="width: 50%; vertical-align: top;"> <ul style="list-style-type: none"> P_o : Running power [kW] P_a : Required power for accel [kW] N_l : Load speed [rpm] N_M : Motor shaft speed [rpm] V_l : Load velocity of load [m/min.] η : Machine efficiency μ : Friction factor W : Weight of load [kg] $G D^2 M$: Motor inertia [kg·m²] $G D^2 L$: Load inertia [kg·m²] $G D^2 L$: Load inertia [kg·m²] (Reflected to shaft) </td> <td style="width: 50%; vertical-align: top;"> <ul style="list-style-type: none"> T_l : Load torque [kg·m] T_L : Load torque [kg·m] (Reflected to shaft) T_M : Motor rated torque [kg·m] t_a : Acceleration time [sec] t_d : Deceleration time [sec] α : 0.8 – 1.2 β : 0.1 – 0.2 (200V class) 0.05 – 0.1 (400V class) </td> </tr> </table>		<ul style="list-style-type: none"> P_o : Running power [kW] P_a : Required power for accel [kW] N_l : Load speed [rpm] N_M : Motor shaft speed [rpm] V_l : Load velocity of load [m/min.] η : Machine efficiency μ : Friction factor W : Weight of load [kg] $G D^2 M$: Motor inertia [kg·m²] $G D^2 L$: Load inertia [kg·m²] $G D^2 L$: Load inertia [kg·m²] (Reflected to shaft) 	<ul style="list-style-type: none"> T_l : Load torque [kg·m] T_L : Load torque [kg·m] (Reflected to shaft) T_M : Motor rated torque [kg·m] t_a : Acceleration time [sec] t_d : Deceleration time [sec] α : 0.8 – 1.2 β : 0.1 – 0.2 (200V class) 0.05 – 0.1 (400V class)
<ul style="list-style-type: none"> P_o : Running power [kW] P_a : Required power for accel [kW] N_l : Load speed [rpm] N_M : Motor shaft speed [rpm] V_l : Load velocity of load [m/min.] η : Machine efficiency μ : Friction factor W : Weight of load [kg] $G D^2 M$: Motor inertia [kg·m²] $G D^2 L$: Load inertia [kg·m²] $G D^2 L$: Load inertia [kg·m²] (Reflected to shaft) 	<ul style="list-style-type: none"> T_l : Load torque [kg·m] T_L : Load torque [kg·m] (Reflected to shaft) T_M : Motor rated torque [kg·m] t_a : Acceleration time [sec] t_d : Deceleration time [sec] α : 0.8 – 1.2 β : 0.1 – 0.2 (200V class) 0.05 – 0.1 (400V class) 			

FORMULA for Calculating Motor Capacity (Cont'd)

in kW N•m	<ul style="list-style-type: none"> • $P_o = \frac{2\pi \cdot T_l \cdot N_l}{60 \cdot \eta} \times 10^{-3}$ [kW] • $P_a = \frac{4J_l \cdot (N_l)^2}{365 \times 10^3 \cdot t_a}$ [kW] • $T_L = \frac{N_l}{N_M \cdot \eta} \cdot T_l$ [N•m] • $J_L = \left(\frac{N_l}{N_M}\right)^2 \cdot J_l$ [kg•m²] • $t_a = \frac{2\pi (J_M + J_L) \cdot N_M}{60 \cdot (T_M \cdot \alpha - T_L)}$ [sec] • $t_d = \frac{2\pi (J_M + J_L) \cdot N_M}{60 \cdot (T_M \cdot \beta + T_L)}$ [sec] 	<ul style="list-style-type: none"> • $P_o = \frac{\mu \cdot W \cdot V_l}{6120 \cdot \eta}$ [kW] • $P_a = \frac{W \cdot (V_l)^2}{3600 \times 10^3 \cdot t_a}$ [kW] • $T_L = \frac{9.8\mu \cdot W \cdot V_l}{2\pi \cdot N_M \cdot \eta}$ [N•m] • $J_L = \frac{1}{4} W \cdot \left(\frac{V_l}{\pi \cdot N_M}\right)^2$ [kg•m²] • $t_a = \frac{2\pi (J_M + J_L) \cdot N_M}{60 \cdot (T_M \cdot \alpha - T_L)}$ [sec] • $t_d = \frac{2\pi (J_M + J_L) \cdot N_M}{60 \cdot (T_M \cdot \beta + T_L)}$ [sec] 		
(SI Unit)	<p>Legend:</p> <table style="width: 100%; border: none;"> <tbody> <tr> <td style="width: 50%; vertical-align: top;"> <ul style="list-style-type: none"> P_o : Running power [kW] P_a : Required power for accel [kW] N_l : Load speed [r/m] N_M : Motor shaft speed [r/m] V_l : Load velocity of load [m/min.] η : Machine efficiency μ : Friction factor W : Weight of load [kg] J_M : Motor inertia [kg•m²] J_l : Load inertia [kg•m²] J_L : Load inertia [kg•m²] (Reflected to motor shaft) </td> <td style="width: 50%; vertical-align: top;"> <ul style="list-style-type: none"> T_l : Load torque [N•m] T_L : Load torque [N•m] (Reflected to motor shaft) T_M : Motor rated torque [N•m] t_a : Acceleration time [sec] t_d : Deceleration time [sec] α : 0.8 – 1.2 β : 0.1 – 0.2 (200V class) 0.05 – 0.1 (400V class) </td> </tr> </tbody> </table>		<ul style="list-style-type: none"> P_o : Running power [kW] P_a : Required power for accel [kW] N_l : Load speed [r/m] N_M : Motor shaft speed [r/m] V_l : Load velocity of load [m/min.] η : Machine efficiency μ : Friction factor W : Weight of load [kg] J_M : Motor inertia [kg•m²] J_l : Load inertia [kg•m²] J_L : Load inertia [kg•m²] (Reflected to motor shaft) 	<ul style="list-style-type: none"> T_l : Load torque [N•m] T_L : Load torque [N•m] (Reflected to motor shaft) T_M : Motor rated torque [N•m] t_a : Acceleration time [sec] t_d : Deceleration time [sec] α : 0.8 – 1.2 β : 0.1 – 0.2 (200V class) 0.05 – 0.1 (400V class)
<ul style="list-style-type: none"> P_o : Running power [kW] P_a : Required power for accel [kW] N_l : Load speed [r/m] N_M : Motor shaft speed [r/m] V_l : Load velocity of load [m/min.] η : Machine efficiency μ : Friction factor W : Weight of load [kg] J_M : Motor inertia [kg•m²] J_l : Load inertia [kg•m²] J_L : Load inertia [kg•m²] (Reflected to motor shaft) 	<ul style="list-style-type: none"> T_l : Load torque [N•m] T_L : Load torque [N•m] (Reflected to motor shaft) T_M : Motor rated torque [N•m] t_a : Acceleration time [sec] t_d : Deceleration time [sec] α : 0.8 – 1.2 β : 0.1 – 0.2 (200V class) 0.05 – 0.1 (400V class) 			

Varispeed-616G3 plus

TOKYO OFFICE

New Pier Takeshiba South Tower, 1-16-1, Kaigan, Minatoku, Tokyo 105 Japan
Phone 81-3-5402-4511 Fax 81-3-5402-4580

YASKAWA ELECTRIC AMERICA, INC.

Chicago-Corporate Headquarters

2942 MacArthur Blvd Northbrook, IL 60062-2028, U S A.

Phone 1-847-291-2340 Fax 1-847-498-2430

Chicago-Technical Center

3160 MacArthur Blvd. Northbrook, IL 60062-1917, U S A

Phone 1-847-291-0411 Fax 1-847-291-1018

MOTOMAN INC. HEADQUARTERS

805 Liberty Lane West Carrollton, OH 45449, U S A

Phone 1-937-847-6200 Fax 1-937-847-6277

YASKAWA ELÉTRICO DO BRASIL COMÉRCIO LTDA.

Avenida Bngadeiro Fana Luma 1664-5° CJ 504/511, São Paulo, Brazil

Phone 55-11-815-7723 Fax 55-11-870-3849

YASKAWA ELECTRIC EUROPE GmbH

Am Kronberger Hang 2, 65824 Schwalbach, Germany

Phone 49-6196-569-300 Fax 49-6196-888-301

Motoman Robotics AB

Box 504 S38525 Torsås, Sweden

Phone 46-486-48800 Fax 46-486-41410

Motoman Robotec GmbH

Kammerfeldstraße 1, 85391 Allershausen, Germany

Phone 49-8166-900 Fax 49-8166-9039

YASKAWA ELECTRIC UK LTD.

3 Drum Mains Park, Orchardton Woods, Cumbernauld, Scotland, G68 9LD, United Kingdom

Phone 44-1236-735000 Fax 44-1236-458182

YASKAWA ELECTRIC KOREA CORPORATION

Paik Nam Bldg 901 188-3, 1-Ga Euljiro, Joong-Gu Seoul, Korea

Phone 82-2-776-7844 Fax 82-2-753-2639

YASKAWA ELECTRIC (SINGAPORE) PTE. LTD.

151 Lorong Chuan, #04-01, New Tech Park Singapore 556741, Singapore

Phone 65-282-3003 Fax 65-289-3003

YATEC ENGINEERING CORPORATION

Shen Hsiang Tang Sung Chiang Building 10F 146 Sung Chiang Road, Taipei, Taiwan

Phone 886-2-563-0010 Fax 886-2-567-4677

BEIJING OFFICE

Room No 301 Office Building of Beijing International Club, 21

Jianguomenwai Avenue, Beijing 100020, China

Phone 86-10-6532-1850 Fax 86-10-6532-1851

SHANGHAI OFFICE

27 Hui He Road Shanghai 200437 China

Phone 86-21-6553-6600 Fax 86-21-6531-4242

YASKAWA JASON (HK) COMPANY LIMITED

Rm 2909-10, Hong Kong Plaza, 186-191 Connaught Road West, Hong Kong

Phone 852-2803-2385 Fax 852-2547-5773

TAIPEI OFFICE

Shen Hsiang Tang Sung Chiang Building 10F 146 Sung Chiang Road, Taipei, Taiwan

Phone 886-2-563-0010 Fax 886-2-567-4677

SHANGHAI YASKAWA-TONGJI M & E CO., LTD.

27 Hui He Road Shanghai China 200437

Phone 86-21-6531-4242 Fax 86-21-6553-6060

BEIJING YASKAWA BEIKE AUTOMATION ENGINEERING CO., LTD.

30 Xue Yuan Road, Haidian, Beijing P R. China Post Code: 100083

Phone 86-10-6233-2782 Fax 86-10-6232-1536



YASKAWA

YASKAWA ELECTRIC CORPORATION

Specifications are subject to change without notice
for ongoing product modifications and improvements