

Quick Start Guide

Five steps to easy startup for your
MICROMASTER 440 drive

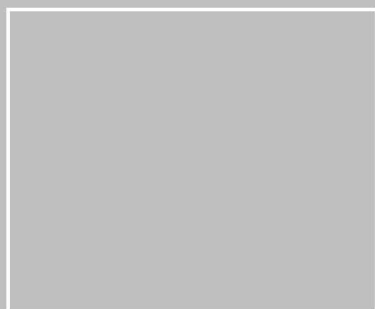





quick start
MM440



SIEMENS

Global network of innovation

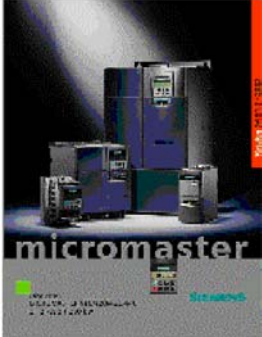
<p>Getting Started Guide</p> <p>Is for quick commissioning with SDP and BOP.</p> <p>Part Number 6SE6400-5AD00-1AP0</p>	
<p>Start-Up Guide</p> <p>Gives basic information necessary for mechanical installation, quick commissioning, Analog and Digital I/O settings, common applications with examples and troubleshooting – specific for the MICROMASTER 440</p> <p>Part Number 6SE6400-5GA00-0BP0</p>	
<p>Operating Instructions</p> <p>Gives information about features of the MICROMASTER 440, Installation, Commissioning, Control modes, System Parameter structure, Troubleshooting, Specifications and available options of the MICROMASTER 440.</p> <p>Part Number 6SE6400-5AW00-0BP0</p>	
<p>Parameter List</p> <p>The Parameter List contains the description of all Parameters structured in functional order and a detailed description. The Parameter list also includes a series of function plans.</p> <p>Part Number 6SE6400-5BB00-0BP0</p>	
<p>Catalogs</p> <p>In the catalog you will find all the necessary information to select an appropriate inverter, as well as filters, chokes, operator panels and communication options.</p> <p>Part Number E86086-K5151-A121-A3-7600</p>	

SIEMENS

MICROMASTER 440

1/6 HP – 350 HP

Quick Start Guide
User Documentation

Valid for

Inverter Type
MICROMASTER 440
1/6 HP – 350 HP

Issue 08/03

Software Version
2.0x

Mechanical Installation	1
Wiring Guidelines / Electrical Installation	2
50Hz / 60Hz Switch	3
Control Wiring Information	4
Parameter Settings	5
Troubleshooting	6

IMPORTANT NOTICE

Not all inverters currently have UL approval.

UL listing can be determined by examining the inverter's Rating Label.

For UL listed products the following UL mark is used:



Note: UL certification is presently in progress!

Further information can be obtained from Internet website:

<http://www.siemens.de/micromaster>

Approved Siemens Quality for Software and Training is to DIN ISO 9001, Reg. No. 2160-01

The reproduction, transmission or use of this document, or its contents is not permitted unless authorized in writing. Offenders will be liable for damages. All rights including rights created by patent grant or registration of a utility model or design are reserved.

© Siemens AG 2001, 2002, 2003. All Rights Reserved.

MICROMASTER® is a registered trademark of Siemens

Other functions not described in this document may be available. However, this fact shall not constitute an obligation to supply such functions with a new control, or when servicing.

We have checked that the contents of this document correspond to the hardware and software described. There may be discrepancies nevertheless, and no guarantee can be given that they are completely identical. The information contained in this document is reviewed regularly and any necessary changes will be included in the next edition. We welcome suggestions for improvement.

Siemens handbooks are printed on chlorine-free paper that has been produced from managed sustainable forests. No solvents have been used in the printing or binding process.

Document subject to change without prior notice.

User Documentation



WARNING

Before installing and commissioning the inverter, you must read all safety instructions and warnings carefully including all the warning labels attached to the equipment. Make sure that the warning labels are kept in a legible condition and replace missing or damaged labels.

Definitions and Warnings



DANGER

indicates an imminently hazardous situation which, if not avoided, will result in death or serious injury.



WARNING

indicates a potentially hazardous situation which, if not avoided, could result in death or serious injury



CAUTION

used with the safety alert symbol indicates a potentially hazardous situation which, if not avoided, may result in minor or moderate injury.

CAUTION

used without safety alert symbol indicates a potentially hazardous situation which, if not avoided, may result in a property damage.

NOTICE

indicates a potential situation which, if not avoided, may result in an undesirable result or state.

NOTE

For the purpose of this documentation, "**NOTE**" indicates important information relating to the product or highlights part of the documentation for special attention.

Qualified personnel

For the purpose of this Instruction Manual and product labels, a "Qualified person" is someone who is familiar with the installation, mounting, start-up and operation of the equipment and the hazards involved.

He or she must have the following qualifications:

1. Trained and authorized to energize, de-energize, clear, ground and tag circuits and equipment in accordance with established safety procedures.
2. Trained in the proper care and use of protective equipment in accordance with established safety procedures.
1. 3. Trained in rendering first aid.



PE – Protective Earth uses circuit protective conductors sized for short circuits where the voltage will not rise in excess of 50 Volts. This connection is normally used to ground the inverter.

- Is the ground connection where the reference voltage can be the same as the Earth voltage. This connection is normally used to ground the motor.

Use for intended purpose only

The equipment may be used only for the application stated in the manual and only in conjunction with devices and components recommended and authorized by Siemens.

Safety Instructions

The following Warnings, Cautions and Notes are provided for your safety and as a means of preventing damage to the product or components in the machines connected. This section lists Warnings, Cautions and Notes, which apply generally when handling MICROMASTER 440 Inverters, classified as **General, Transport & Storage, Commissioning, Operation, Repair and Dismantling & Disposal.**

Specific Warnings, Cautions and Notes that apply to particular activities are listed at the beginning of the relevant chapters and are repeated or supplemented at critical points throughout these sections.

Please read the information carefully, since it is provided for your personal safety and will also help prolong the service life of your MICROMASTER 440 Inverter and the equipment you connect to it.

General



WARNING

- This equipment contains dangerous voltages and controls potentially dangerous rotating mechanical parts. Non-compliance with **Warnings** or failure to follow the instructions contained in this manual can result in loss of life, severe personal injury or serious damage to property.
- Only suitable qualified personnel should work on this equipment, and only after becoming familiar with all safety notices, installation, operation and maintenance procedures contained in this manual. The successful and safe operation of this equipment is dependent upon its proper handling, installation, operation and maintenance.
- Risk of electric shock. The DC link capacitors remain charged for five minutes after power has been removed. **It is not permissible to open the equipment until 5 minutes after the power has been removed.**
- The following terminals can carry dangerous voltages even if the inverter is inoperative: The power supply L/L1, N/L2, L3 resp. U1/L1, V1/L2, W1/L3 the motor terminals U, V, W resp. U2/T1, V2/T2, W2/T3 and depending on the frame size the terminals DC+/B+, DC-, B-, DC/R+ resp. C/L+, D/L-
- **HP ratings are based on the Siemens 1LA motors and are given for guidance only; they do not necessarily comply with UL or NEMA HP ratings.**



CAUTION

- Children and the general public must be prevented from accessing or approaching the equipment!
- This equipment may only be used for the purpose specified by the manufacturer. Unauthorized modifications and the use of spare parts and accessories that are not sold or recommended by the manufacturer of the equipment can cause fires, electric shocks and injuries.

NOTICE

- Keep these operating instructions within easy reach of the equipment and make them available to all users
 - Whenever measuring or testing has to be performed on live equipment, the regulations of Safety Code BGV A2 must be observed, in particular §8 "Permissible Deviations when Working on Live Parts". Suitable electronic tools should be used.
 - Before installing and commissioning, please read these safety instructions and warnings carefully and all the warning labels attached to the equipment. Make sure that the warning labels are kept in a legible condition and replace missing or damaged labels.
-

Transport & Storage



WARNING

Correct transport, storage, erection and mounting, as well as careful operation and maintenance are essential for proper and safe operation of the equipment.



CAUTION

Protect the inverter against physical shocks and vibration during transport and storage. Also be sure to protect it against water (rainfall) and excessive temperatures (see Table 4-1).

Commissioning



WARNING

- Work on the device/system by **unqualified** personnel or failure to comply with warnings can result in severe personal injury or serious damage to material. Only suitably qualified personnel trained in the setup, installation, commissioning and operation of the product should carry out work on the device/system.
 - Only permanently-wired input power connections are allowed. This equipment must be grounded (IEC 536 Class 1, NEC and other applicable standards).
 - Only type B ELCBs should be used with Frame Size A to Frame Size F. Machines with a three phase power supply, fitted with EMC filters, must not be connected to a supply via an ELCB (Earth Leakage Circuit-Breaker - see *DIN VDE 0160, section 5.5.2 and EN50178 section 5.2.11.1*).
 - The following terminals can carry dangerous voltages even if the inverter is inoperative:
 - The power supply L/L1, N/L2, L3 resp. U1/L1, V1/L2, W1/L3. the motor terminals U, V, W resp. U2/T1, V2/T2, W2/T3. and depending on the frame size the terminals DC+/B+, DC-, B-, DC/R+ resp. C/L+, D/L-
 - This equipment must not be used as an 'emergency stop mechanism' (see *EN 60204, 9.2.5.4*)
-



CAUTION

The connection of power, motor and control cables to the inverter must be carried out as shown in Figure 2-6 Motor and Power Connections on page 21, to prevent inductive and capacitive interference from affecting the correct functioning of the inverter.

Operation



WARNING

- MICROMASTERS operate at high voltages.
 - When operating electrical devices, it is impossible to avoid applying hazardous voltages to certain parts of the equipment.
 - Emergency Stop facilities according to EN 60204 IEC 204 (VDE 0113) must remain operative in all operating modes of the control equipment. Any disengagement of the Emergency Stop facility must not lead to uncontrolled or undefined restart. Certain parameter settings may cause the inverter to restart automatically after an input power failure (e.g. automatic restart).
 - Wherever faults occurring in the control equipment can lead to substantial material damage or even grievous bodily injury (i.e. potentially dangerous faults), additional external precautions must be taken or facilities provided to ensure or enforce safe operation, even when a fault occurs (e.g. independent limit switches, mechanical interlocks, etc.).
 - Motor parameters must be accurately configured for motor overload protection to operate correctly.
 - This equipment is capable of providing internal motor overload protection in accordance with UL508C section 42. Refer to P0610 and P0335, i2t is ON by default. Motor overload protection can also be provided using an external PTC (disabled by default P0601).
 - This equipment is suitable for use in a circuit capable of delivering not more than 10,000 symmetrical amperes (rms), for a maximum voltage of 230 V / 460 V / 575 V when protected by J type fuse.
 - This equipment must not be used as an 'emergency stop mechanism' (see EN 60204, 9.2.5.4)
-

Repair



WARNING

- Repairs on equipment may only be carried out by **Siemens Service Centers**.
 - Any defective parts or components must be replaced using parts contained in the relevant spare parts list.
 - Disconnect the power supply before opening the equipment for access
-

Dismantling & Disposal



CAUTION

- The inverter's packaging is re-usable. Retain the packaging for future use.
 - Easy-to-release screw and snap connectors allow you to break the unit down into its component parts. You can then re-cycle these component parts, dispose of them in **accordance with local requirements or return them to the manufacturer.**
-

Table of Contents

1	Mechanical Installation	11
1.1	Drilling Patterns and Dimensions.....	11
1.2	Environment, Heat Loss and Air Flow	14
2	Wiring Guidelines / Electrical Installation	17
2.1	Power Terminal Layouts.....	17
2.2	Adaptation of Fan Voltage (Only Frame Size FX and GX)	20
2.3	Motor and Power Connections	21
2.4	Recommended Power Supplies for 3ph Connection	22
2.5	Removal of Y Capacitor.....	23
2.6	Wiring Diagrams for Motors.....	24
2.7	When to Use Line Reactors (Input Chokes)	25
2.8	When to Use Load Reactors (Output Chokes)	25
2.9	Fuses, Circuit Breakers, Line Reactors, Output Reactors	26
2.10	Power Cable Dimensions	29
3	50Hz / 60Hz Switch	33
3.1	How to Remove I/O Card to Get At Switches	34
4	Control Wiring.....	37
4.1	Control Block Diagram,.....	37
4.2	Control Wiring Examples	38
5	Setting Parameters	43
5.1	Introduction to Basic Operator Panel (BOP).....	43
5.2	Factory Reset	44
5.3	Commissioning an MM440	44
5.4	Reading Motor Name Plates	45
5.5	Level 3 Quick Commissioning	46
5.6	Checking Direction of Motor Rotation	52
5.7	Parameter Filter Function	52
5.8	Setting up Inputs and Outputs,	53
5.9	Other Commonly Used Features	60
6	Troubleshooting	62
6.1	Troubleshooting Using the Status Display Panel (SDP).....	62
6.2	Faults and Alarms (Warnings)	64
6.3	Where to Get Additional Technical Information	67

1 Mechanical Installation

1.1 Drilling Patterns and Dimensions

Frame Size A - Frame Size C

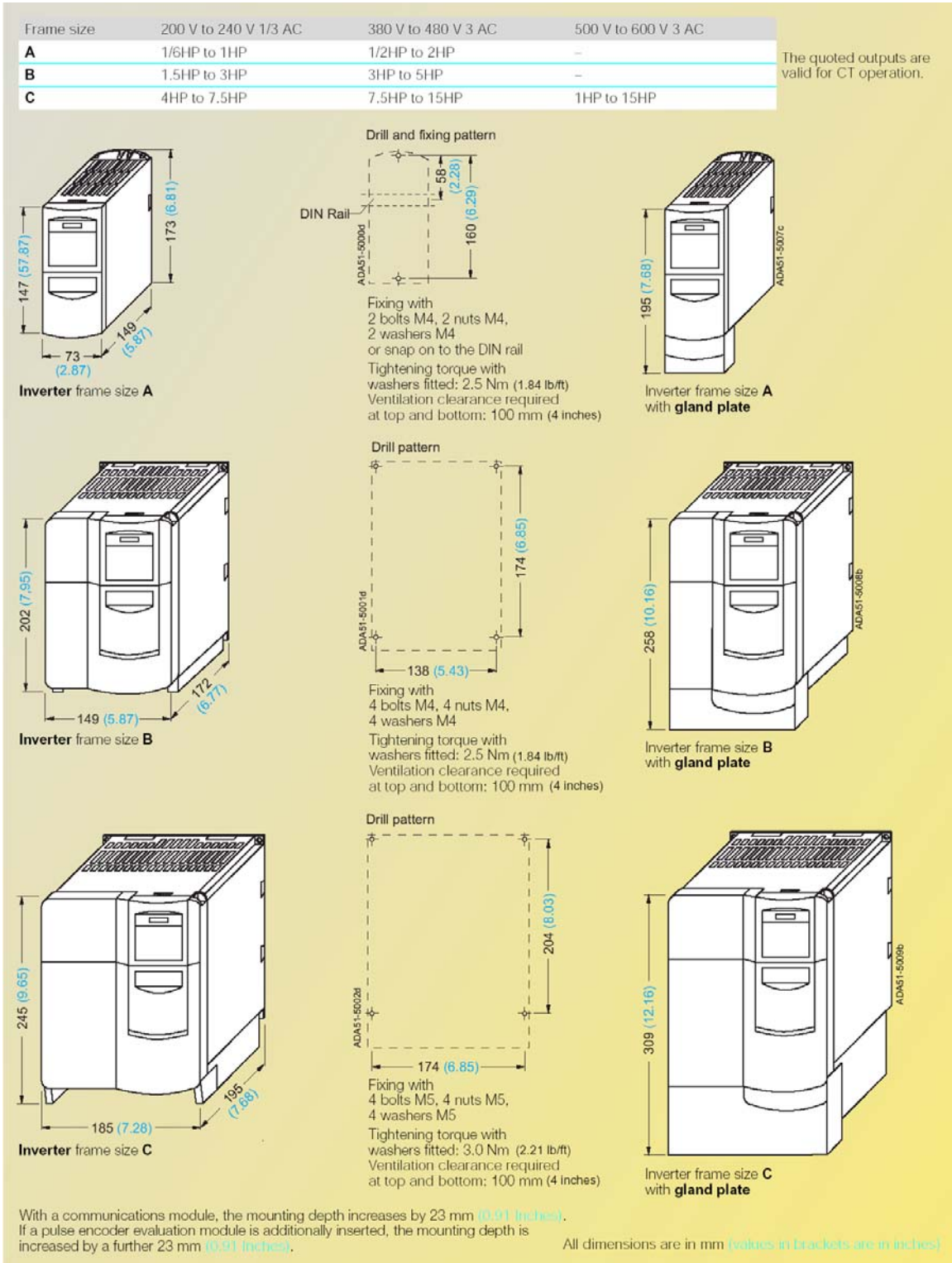

Figure 1-1 Drilling Pattern & Dimensions Frame Size A - Frame Size C

Frame Size E – Frame Size F

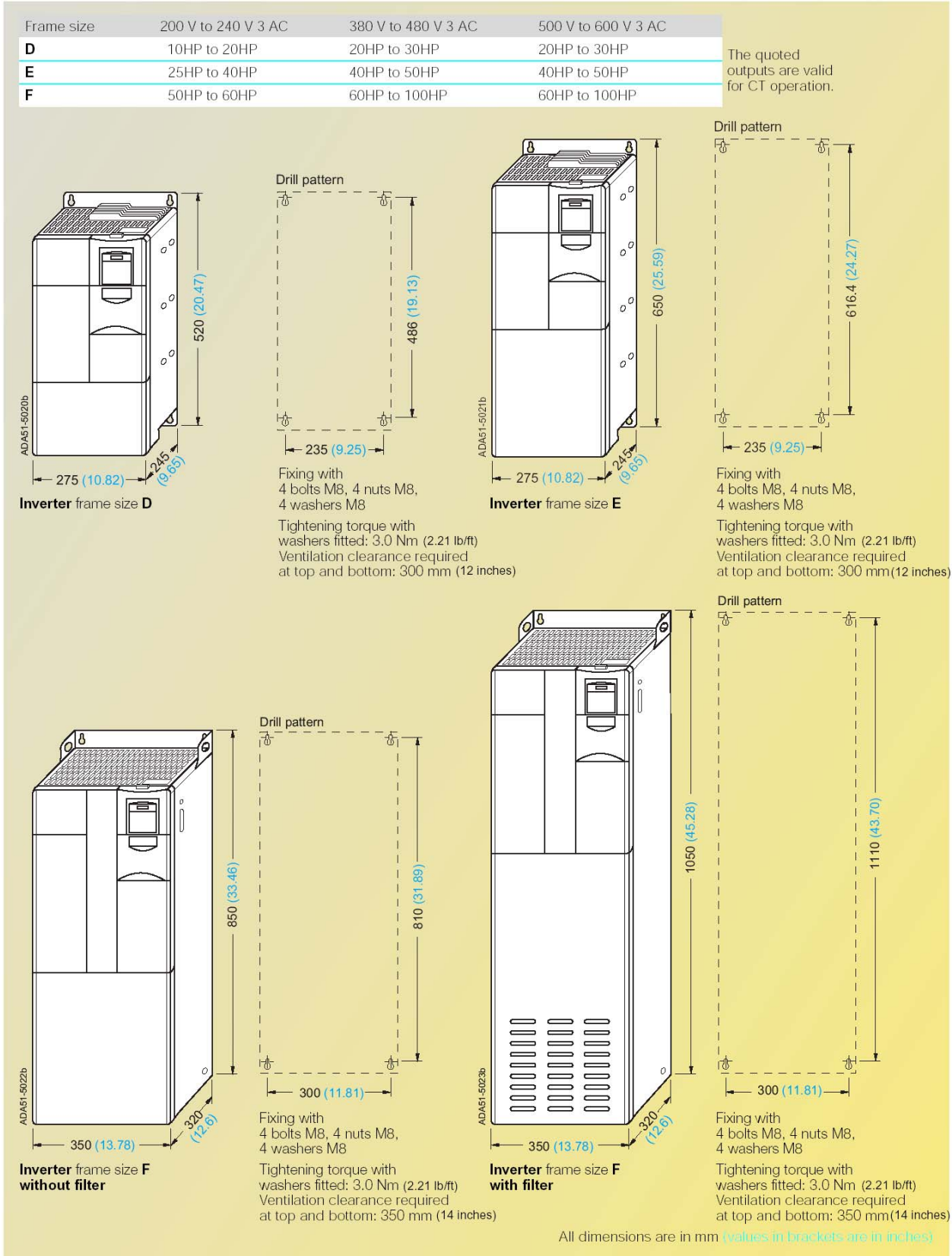

Figure 1-2 Drilling Pattern & Dimensions Frame Size E - Frame Size F

Frame Size FX – Frame Size GX

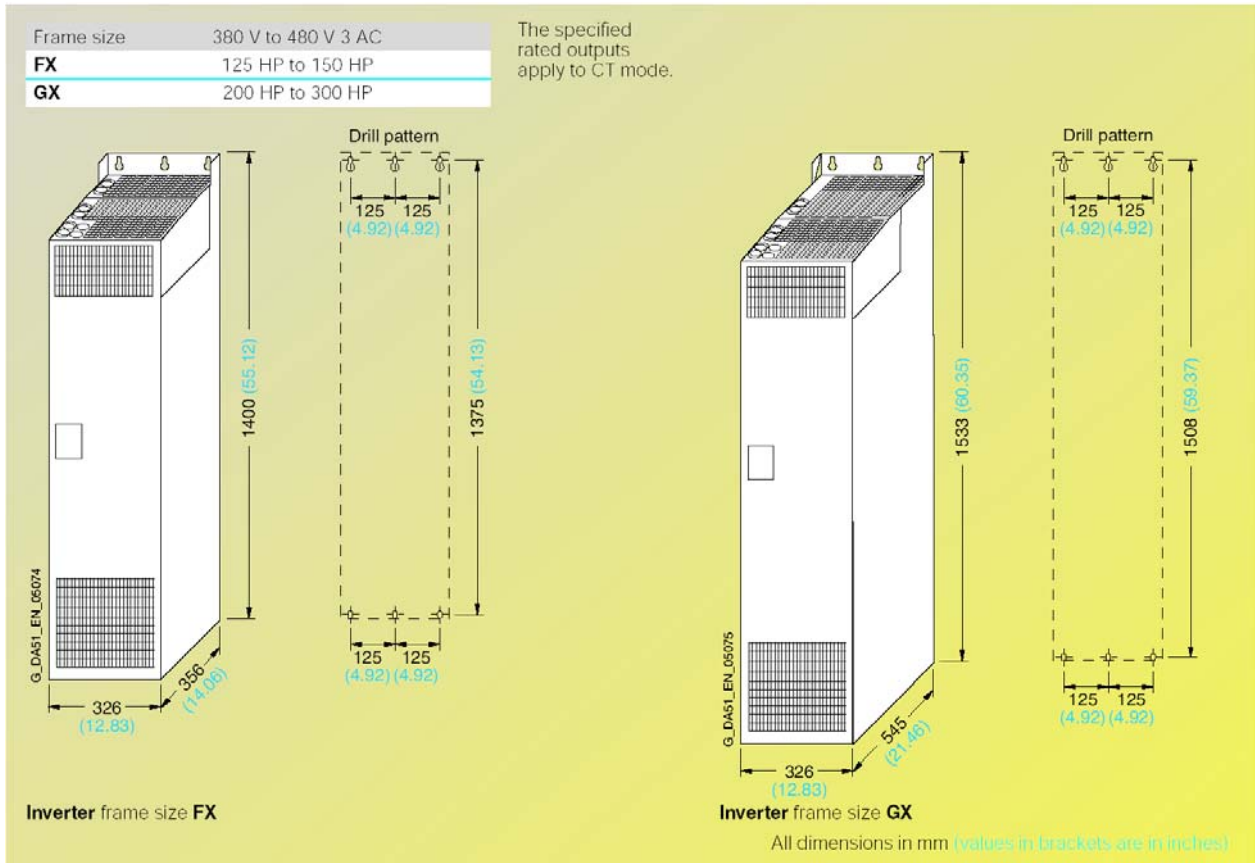

Figure 1-3 Drilling Pattern & Dimensions Frame Size FX - Frame Size GX

1.2 Environment, Heat Loss and Air Flow

These figures should be used when mounting MICROMASTER 440s into enclosures.

Figures shown are for unfiltered units. You can assume that the filtered versions of these drives (where available) have similar figures.

Drive Part Number.	Heat Loss (W)	Clearance Required Above Drive – Inches (mm)	Clearance Required Below Drive – Inches (mm)	Air Flow - CFM (m ³ /min)
1ph 230V Input				
6SE6440-2UC11-2AA1	5	4" (100mm)	4" (100mm)	10.2 (0.29)
6SE6440-2UC12-5AA1	10	4" (100mm)	4" (100mm)	10.2 (0.29)
6SE6440-2UC13-7AA1	15	4" (100mm)	4" (100mm)	10.2 (0.29)
6SE6440-2UC15-5AA1	22	4" (100mm)	4" (100mm)	10.2 (0.29)
6SE6440-2UC17-5AA1	30	4" (100mm)	4" (100mm)	10.2 (0.29)
6SE6440-2UC21-1BA1	39	4" (100mm)	4" (100mm)	51 (1.44)
6SE6440-2UC21-5BA1	53	4" (100mm)	4" (100mm)	51 (1.44)
6SE6440-2UC22-2BA1	77	4" (100mm)	4" (100mm)	51 (1.44)
6SE6440-2UC23-0CA1	90	4" (100mm)	4" (100mm)	116 (3.28)
3ph 230V Input				
6SE6440-2UC11-2AA1	5	4" (100mm)	4" (100mm)	10.2 (0.29)
6SE6440-2UC12-5AA1	10	4" (100mm)	4" (100mm)	10.2 (0.29)
6SE6440-2UC13-7AA1	15	4" (100mm)	4" (100mm)	10.2 (0.29)
6SE6440-2UC15-5AA1	22	4" (100mm)	4" (100mm)	10.2 (0.29)
6SE6440-2UC17-5AA1	30	4" (100mm)	4" (100mm)	10.2 (0.29)
6SE6440-2UC21-1BA1	39	4" (100mm)	4" (100mm)	51 (1.44)
6SE6440-2UC21-5BA1	53	4" (100mm)	4" (100mm)	51 (1.44)
6SE6440-2UC22-2BA1	77	4" (100mm)	4" (100mm)	51 (1.44)
6SE6440-2UC23-0CA1	90	4" (100mm)	4" (100mm)	116 (3.28)
6SE6440-2UC24-0CA1	120	4" (100mm)	4" (100mm)	116 (3.28)
6SE6440-2UC25-5CA1	165	4" (100mm)	4" (100mm)	116 (3.28)
6SE6440-2UC27-5DA1	225	12" (300mm)	12" (300mm)	116 (3.28)
6SE6440-2UC31-1DA1	330	12" (300mm)	12" (300mm)	116 (3.28)
6SE6440-2UC31-5DA1	450	12" (300mm)	12" (300mm)	116 (3.28)
6SE6440-2UC31-8EA1	555	12" (300mm)	12" (300mm)	233 (6.60)
6SE6440-2UC32-2EA1	660	12" (300mm)	12" (300mm)	233 (6.60)
6SE6440-2UC33-0FA1	900	14" (350mm)	14" (350mm)	318 (9.00)
6SE6440-2UC33-7FA1	1100	14" (350mm)	14" (350mm)	318 (9.00)
6SE6440-2UC34-5FA1	1350	14" (350mm)	14" (350mm)	318 (9.00)

Figure 1-4 Heat Loss, Clearances & Air Flow (230V)

Drive Part Number.	Heat Loss (W)	Clearance Required Above Drive	Clearance Required Below Drive	Clearance Required In front of Drive	Air Flow - CFM (m ³ /min)
3ph 460V Input					
6SE6440-2UD13-7AA1	15	4" (100mm)	4" (100mm)	-	10.2 (0.29)
6SE6440-2UD15-5AA1	22	4" (100mm)	4" (100mm)	-	10.2 (0.29)
6SE6440-2UD17-5AA1	30	4" (100mm)	4" (100mm)	-	10.2 (0.29)
6SE6440-2UD21-1AA1	39	4" (100mm)	4" (100mm)	-	10.2 (0.29)
6SE6440-2UD21-5AA1	53	4" (100mm)	4" (100mm)	-	10.2 (0.29)
6SE6440-2UD22-2BA1	77	4" (100mm)	4" (100mm)	-	51 (1.44)
6SE6440-2UD23-0BA1	90	4" (100mm)	4" (100mm)	-	51 (1.44)
6SE6440-2UD24-0BA1	120	4" (100mm)	4" (100mm)	-	51 (1.44)
6SE6440-2UD25-5CA1	165	4" (100mm)	4" (100mm)	-	116 (3.28)
6SE6440-2UD27-5CA1	225	4" (100mm)	4" (100mm)	-	116 (3.28)
6SE6440-2UD31-1CA1	330	4" (100mm)	4" (100mm)	-	116 (3.28)
6SE6440-2UD31-5DA1	450	12" (300mm)	12" (300mm)	-	116 (3.28)
6SE6440-2UD31-8DA1	555	12" (300mm)	12" (300mm)	-	116 (3.28)
6SE6440-2UD32-2DA1	660	12" (300mm)	12" (300mm)	-	116 (3.28)
6SE6440-2UD33-0EA1	900	12" (300mm)	12" (300mm)	-	233 (6.60)
6SE6440-2UD33-7EA1	1100	12" (300mm)	12" (300mm)	-	233 (6.60)
6SE6440-2UD34-5FA1	1350	14" (350mm)	14" (350mm)	-	318 (9.00)
6SE6440-2UD35-5FA1	1650	14" (350mm)	14" (350mm)	-	318 (9.00)
6SE6440-2UD37-5FA1	2250	14" (350mm)	14" (350mm)	-	318 (9.00)
6SE6440-2UD38-8FA1	2700	10" (250mm)	6" (150mm)	4" (100mm)	477 (13.51)
6SE6440-2UD41-1FA1	3300	10" (250mm)	6" (150mm)	4" (100mm)	477 (13.51)
6SE6440-2UD41-3GA1	3960	10" (250mm)	6" (150mm)	4" (100mm)	932 (26.39)
6SE6440-2UD41-6GA1	4800	10" (250mm)	6" (150mm)	4" (100mm)	932 (26.39)
6SE6440-2UD42-0GA1	6000	10" (250mm)	6" (150mm)	4" (100mm)	932 (26.39)
3ph 575V Input					
6SE6440-2UE17-5CA1	30	4" (100mm)	4" (100mm)	-	116 (3.28)
6SE6440-2UE21-5CA1	53	4" (100mm)	4" (100mm)	-	116 (3.28)
6SE6440-2UE22-2CA1	77	4" (100mm)	4" (100mm)	-	116 (3.28)
6SE6440-2UE24-0CA1	120	4" (100mm)	4" (100mm)	-	116 (3.28)
6SE6440-2UE25-5CA1	165	4" (100mm)	4" (100mm)	-	116 (3.28)
6SE6440-2UE27-5CA1	225	4" (100mm)	4" (100mm)	-	116 (3.28)
6SE6440-2UE31-1CA1	330	4" (100mm)	4" (100mm)	-	116 (3.28)
6SE6440-2UE31-5DA1	450	12" (300mm)	12" (300mm)	-	116 (3.28)
6SE6440-2UE31-8DA1	555	12" (300mm)	12" (300mm)	-	116 (3.28)
6SE6440-2UE32-2DA1	660	12" (300mm)	12" (300mm)	-	116 (3.28)
6SE6440-2UE33-0EA1	900	12" (300mm)	12" (300mm)	-	233 (6.60)
6SE6440-2UE33-7EA1	1100	12" (300mm)	12" (300mm)	-	233 (6.60)
6SE6440-2UE34-5FA1	1350	14" (350mm)	14" (350mm)	-	318 (9.00)
6SE6440-2UE35-5FA1	1650	14" (350mm)	14" (350mm)	-	318 (9.00)
6SE6440-2UE37-5FA1	2250	14" (350mm)	14" (350mm)	-	318 (9.00)

Figure 1-5 Heat Loss, Clearances & Air Flow (460V, 575V)

2 Wiring Guidelines / Electrical Installation

2.1 Power Terminal Layouts

Frame Sizes A to Frame Size F

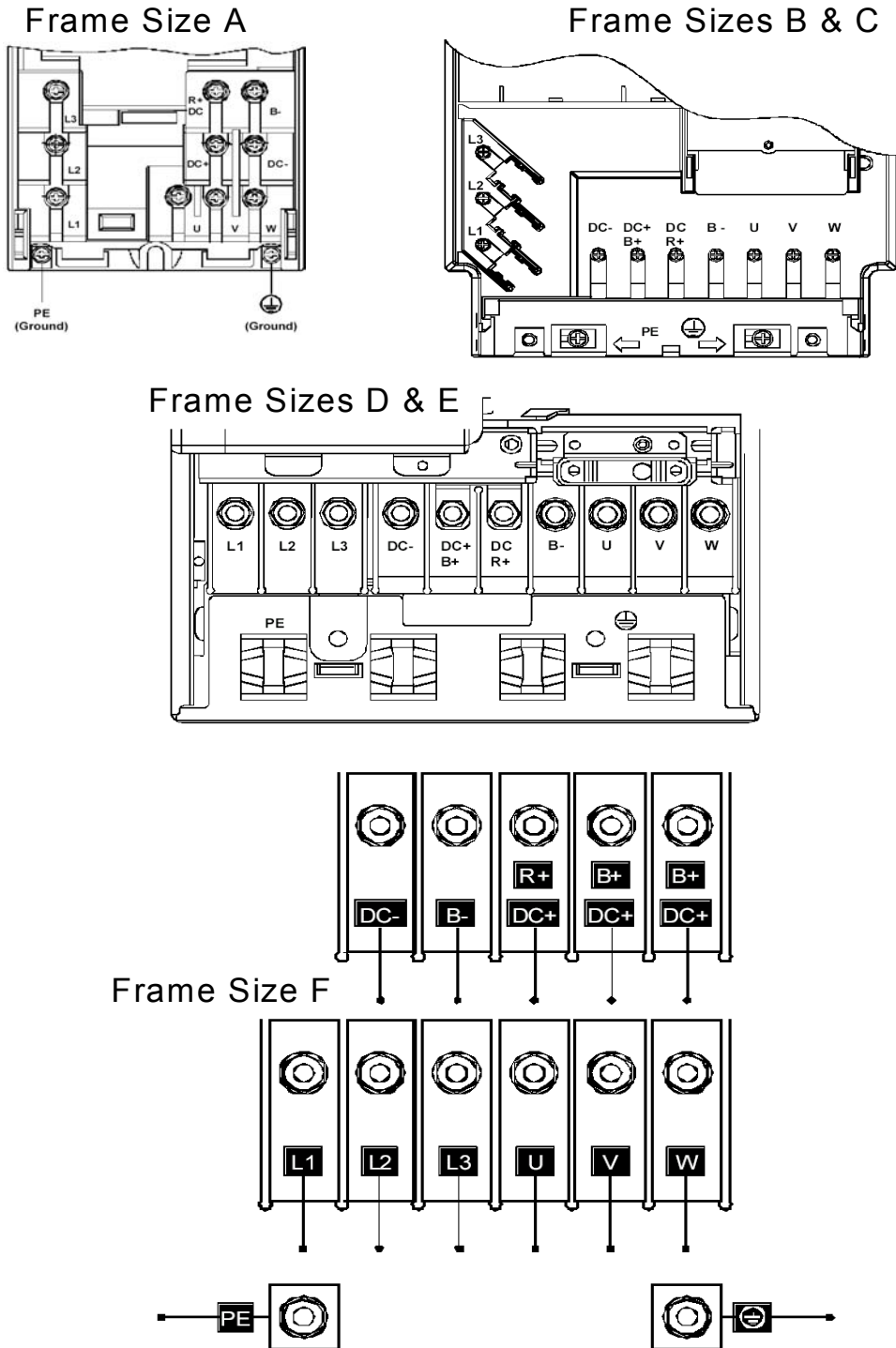

Figure 2-1 Power Terminal Layouts Frame Size A to Frame Size F

2.1.1 Frame Size FX Power Terminals

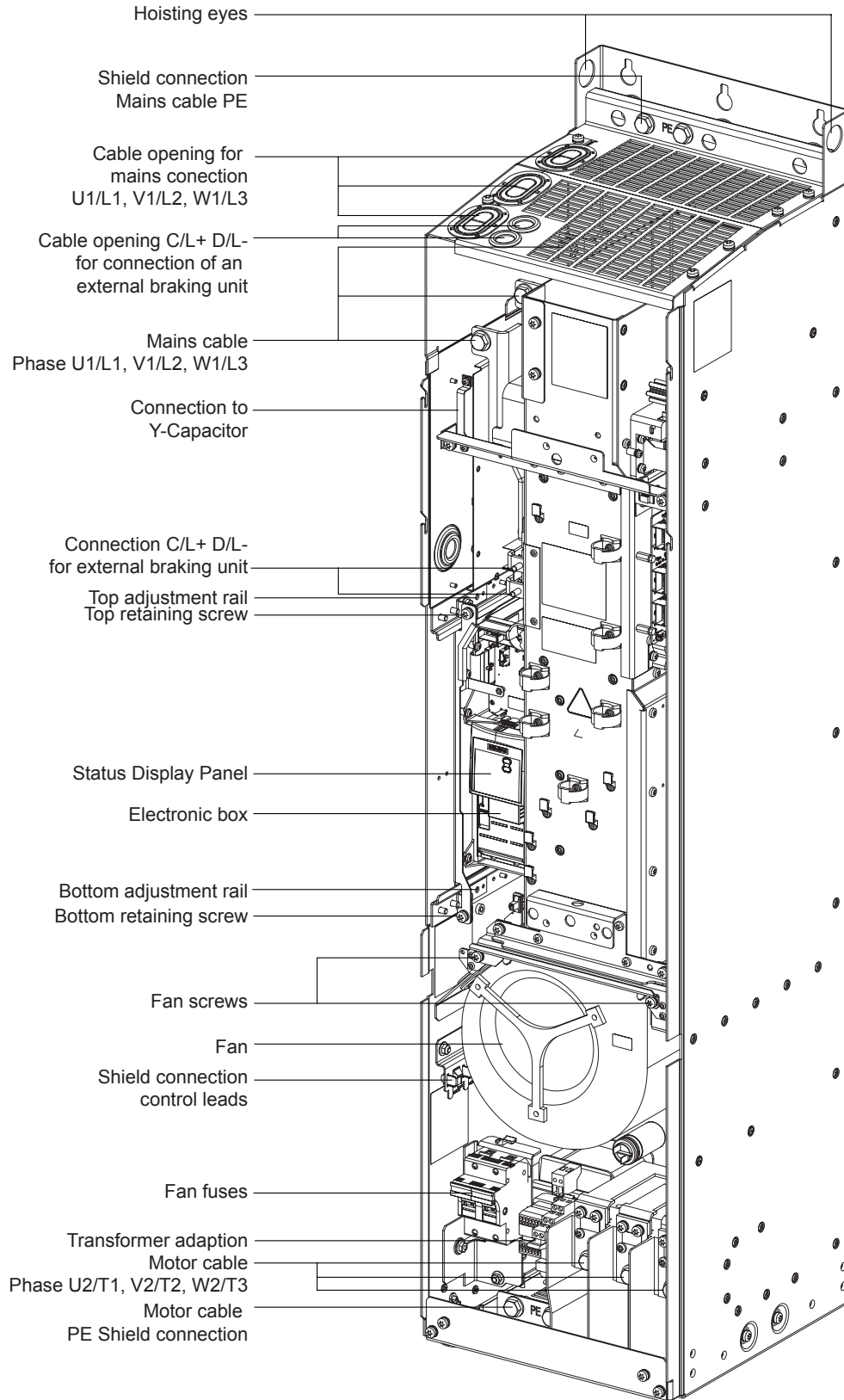

Figure 2-2 Layout of Frame Size FX

2.1.2 Frame Size GX Power Terminals

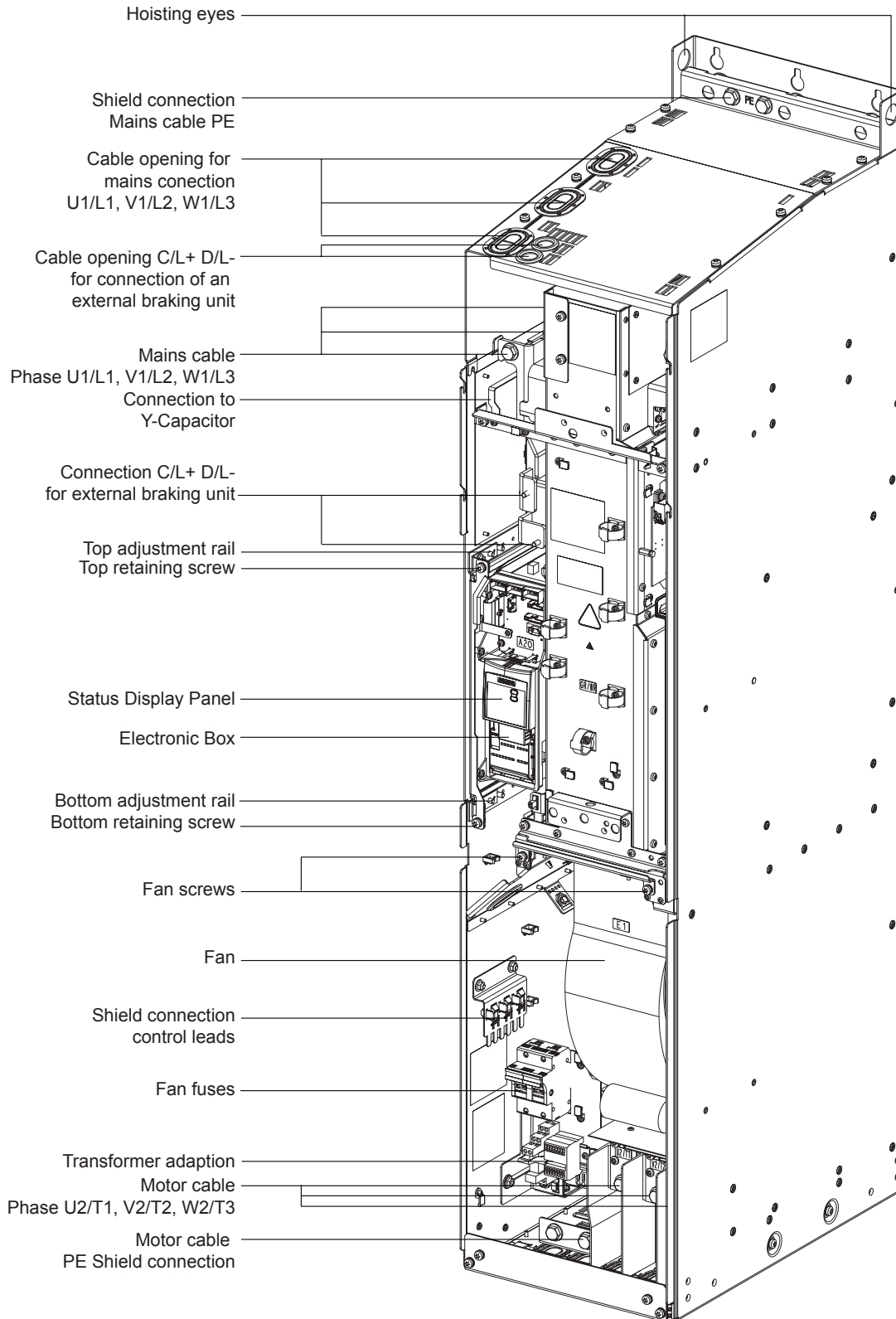

Figure 2-3 Power Terminals Frame Size GX

2.2 Adaptation of Fan Voltage (Only Frame Size FX and GX)

A transformer is installed to adapt the cooling fan to the line voltage. It may be necessary to reconnect the transformer terminals on the primary side to match up with the line voltage.

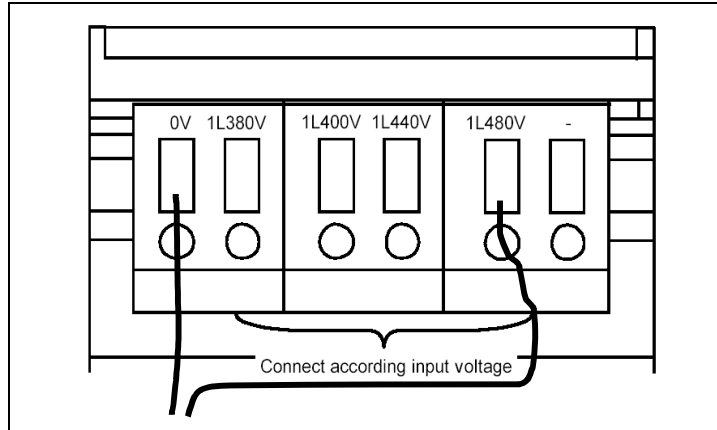

Figure 2-4 Frame Size FX, Frame Size GX Fan Adaptation Terminals

NOTE

You will most likely connect to the 480V terminals in the USA – however you should check to see what your actual line supply voltage is.



CAUTION

If the terminals are not correctly connected according to the line voltage, the fan fuses can blow.

Replacement for fan fuses

Frame size	Fuses (2 each)	Recommended fuses	Part Number for spare fuse
FX (125HP CT)	1 A / 600 V / slow-acting	Cooper-Bussmann FNQ-R-1, 600 V or comparable fuse	6SL3352-7BE32-1AA1
FX (150 HP CT)	2,5 A / 600 V / slow-acting	Ferraz Gould Shawmut ATDR2-1/2, 600 V or comparable fuse	6SY7000-0AC46
GX (200-300 HP CT)	4 A / 600 V / slow-acting	Ferraz Gould Shawmut ATDR4, 600 V or comparable fuse	6SY7000-0AC48

Table 2-5 Replacement Fuses for Frame Size FX, Frame Size GX Fans

2.3 Motor and Power Connections

MICROMASTER 440 drives and options should always be connected up in accordance with the diagram below:

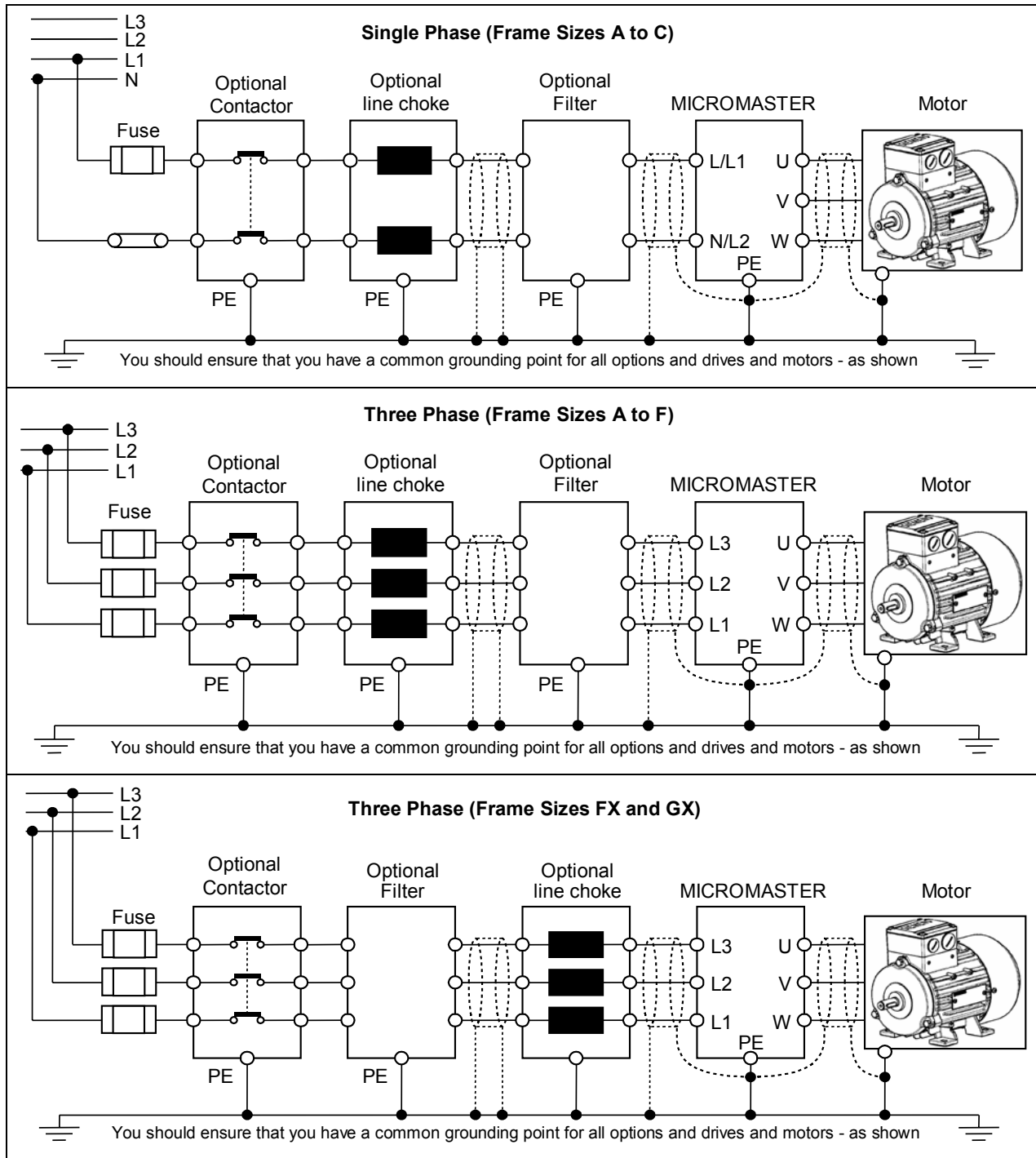

Figure 2-6 Motor and Power Connections

2.4 Recommended Power Supplies for 3ph Connection

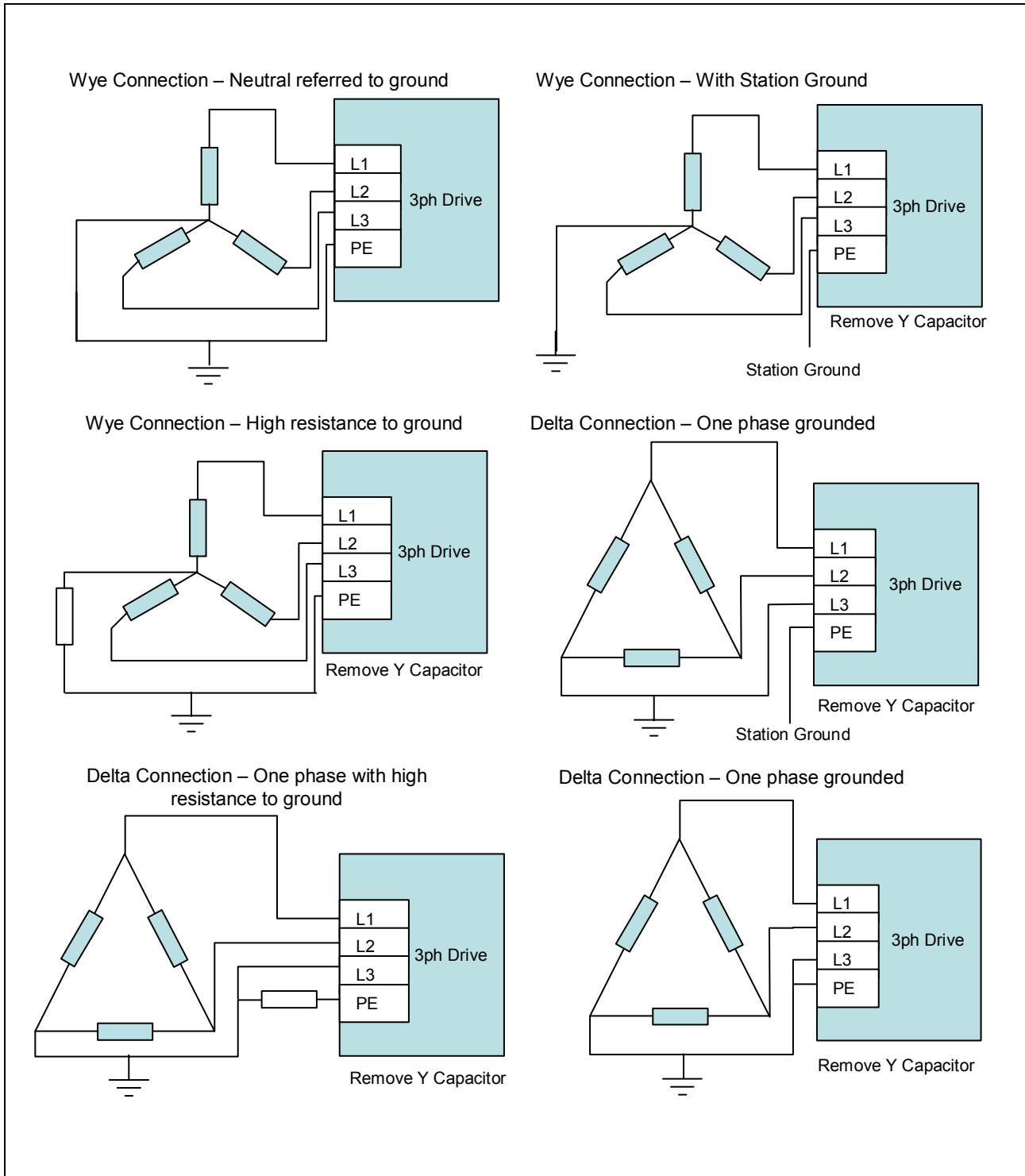

Figure 2-7 - Recommended Power Supplies

NOTE

For ALL other line configurations an isolation transformer should be used with a grounded Wye secondary.

2.5 Removal of Y Capacitor

On ungrounded power supplies, it will be necessary to disconnect the 'Y' capacitor from the inside of the unit and fit an output choke.

For instructions on the removal of the Y Capacitor please see the operating instructions.

The purpose of the choke is to limit high frequency circulating currents that can flow during earth faults. These would cause high currents in the output devices, leading to excessive dissipation and possible damage.

Further Considerations:

1. Operation on ungrounded power supplies is only possible with unfiltered units. Filtered units (or units which do not have their 'Y' capacitors disconnected) will be damaged after running for a short time.
2. An output choke is recommended to limit the fault current during an ground fault. All qualification tests have been carried out using an output choke.
3. It is often the case that ungrounded power supplies have high levels of transients and interference. Supplies should be checked for damaging transients *before* fitting MM4. If in doubt, an input choke should be installed.

Supply arrangements:

An ungrounded supply is one where the ground is not electrically connected to the inverter input (see section 2.4). This arrangement is sometimes used in some industrial installations because, in the event of an earth fault occurring, the equipment may continue to run.



CAUTION

Ungrounded does not mean there is no ground connection at all. All Siemens drives must always be grounded. This is important for safety reasons.

2.6 Wiring Diagrams for Motors

The diagrams below show the typical wiring notation found on NEMA and IEC motors

2.6.1 NEMA Motor

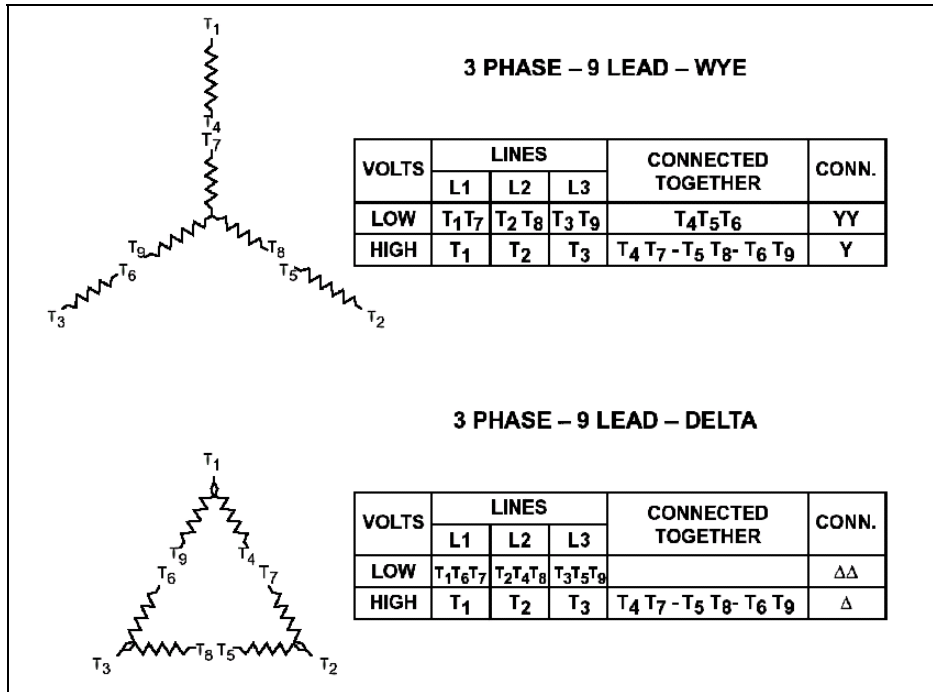

Figure 2-8 NEMA Motor Connections

2.6.2 IEC Motor

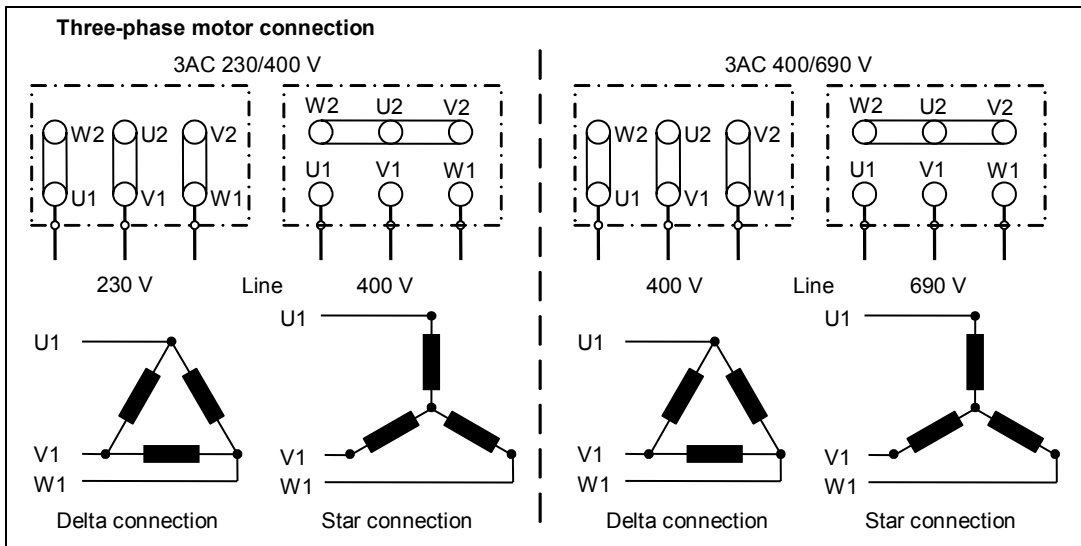

Figure 2-9 IEC Motor Connections

NOTE

Refer to page 45 for information on reading the motor name plate data.

2.7 When to Use Line Reactors (Input Chokes)

Line commutating chokes are used to smooth voltage peaks (line disturbances), or to bridge commutating dips. In addition, line commutation chokes reduce the effects of harmonics on the drive, and on the power supply.

If the short circuit capability of the line supply is >100 times larger than the nominal input current of the drive then a line commutation reactor must be used. If the capability of the line supply is unknown then a line commutating reactor should also be used.

Siemens offers a range of line reactors that are footprint-mountable up to Frame Size E (50HP CT, 460V), reducing enclosure space and offering a very neat solution.

2.8 When to Use Load Reactors (Output Chokes)

Load reactors should be used when motor cables exceed the following lengths:

For drives 0.16 – 100HP, 150 Feet (Shielded) 300 Feet (Unshielded)

For drives 125 – 300HP, 300 Feet (Shielded), 450 Feet (unshielded).

Siemens offers a range of output chokes that are footprint-mountable up to Frame Size C (15HP CT, 460V), reducing enclosure space and offering a very neat solution.

The table below shows the *shielded* cable lengths that can be attained using the Siemens load reactors. You can get approximately 50% more length if you use unshielded cable.

Frame Size	Choke Part Number	200-240 ± 10%	380 – 400 ± 10 %	401 – 480 ± 10 %	480 – 540 ± 10 %
A	6SE6400-3TC00-4AD3	600 feet	-	-	-
A	6SE6400-3TC00-4AD2	600 feet	450 feet	300 feet	-
B	6SE6400-3TC01-0BD3	600 feet	450 feet	300 feet	-
C	6SE6400-3TC03-2CD3	600 feet	600 feet	300 feet	-
C	6SE6400-3TC01-8CE3	-	-	-	300 feet

Table 2-10 Cable lengths using Siemens Load Reactors

For all other frame sizes, Siemens load reactors allow up to 600 feet with shielded cable or up to 900 feet with unshielded cable across the recommended voltage range.

2.9 Fuses, Circuit Breakers, Line Reactors, Output Reactors

Drive Part Number.	HP	Recommended Class J Fuse (Amps)	Circuit Breaker (Amps)	Circuit Breaker Type	Line Reactor	Output Reactor
1ph 230V Input						
6SE6440-2UC11-2AA1	1/6	6	15	ED4	6SE6400-3CC00-4AB3	6SE6400-3TC00-4AD2
6SE6440-2UC12-5AA1	1/3	10	15	ED4	6SE6400-3CC00-4AB3	6SE6400-3TC00-4AD2
6SE6440-2UC13-7AA1	1/2	10	15	ED4	6SE6400-3CC01-0AB3	6SE6400-3TC00-4AD2
6SE6440-2UC15-5AA1	3/4	15	15	ED4	6SE6400-3CC01-0AB3	6SE6400-3TC00-4AD2
6SE6440-2UC17-5AA1	1	15	15	ED4	6SE6400-3CC01-0AB3	6SE6400-3TC00-4AD2
6SE6440-2UC21-1BA1	1.5	20	30	ED4	6SE6400-3CC02-6BB3	6SE6400-3TC01-0BD3
6SE6440-2UC21-5BA1	2	25	30	ED4	6SE6400-3CC02-6BB3	6SE6400-3TC01-0BD3
6SE6440-2UC22-2BA1	3	30	30	ED4	6SE6400-3CC02-6BB3	6SE6400-3TC01-0BD3
6SE6440-2UC23-0CA1	4	40	60	ED4	6SE6400-3CC03-5CB3	6SE6400-3TC03-2CD3

Drive Part Number.	HP	Recommended Class J Fuse (Amps)	Circuit Breaker (Amps)	Circuit Breaker Type	Line Reactor	Output Reactor
3ph 230V Input						
6SE6440-2UC11-2AA1	1/6	4	15	ED4	6SE6400-3CC00-3AC3	6SE6400-3TC00-4AD2
6SE6440-2UC12-5AA1	1/3	4	15	ED4	6SE6400-3CC00-3AC3	6SE6400-3TC00-4AD2
6SE6440-2UC13-7AA1	½	6	15	ED4	6SE6400-3CC00-5AC3	6SE6400-3TC00-4AD2
6SE6440-2UC15-5AA1	¾	6	15	ED4	6SE6400-3CC00-5AC3	6SE6400-3TC00-4AD2
6SE6440-2UC17-5AA1	1	10	15	ED4	6SE6400-3CC00-5AC3	6SE6400-3TC00-4AD2
6SE6440-2UC21-1BA1	1.5	15	15	ED4	6SE6400-3CC00-8BC3	6SE6400-3TC01-0BD3
6SE6440-2UC21-5BA1	2	15	15	ED4	6SE6400-3CC01-4BD3	6SE6400-3TC01-0BD3
6SE6440-2UC22-2BA1	3	20	30	ED4	6SE6400-3CC01-4BD3	6SE6400-3TC01-0BD3
6SE6440-2UC23-0CA1	4	25	30	ED4	6SE6400-3CC01-7CC3	6SE6400-3TC03-2CD3
6SE6440-2UC24-0CA1	5	30	30	ED4	6SE6400-3CC03-5CD3	6SE6400-3TC03-2CD3
6SE6440-2UC25-5CA1	7 ½	40	60	ED4	6SE6400-3CC03-5CD3	6SE6400-3TC03-2CD3
6SE6440-2UC27-5DA1	10	60	60	ED4	6SE6400-3CC05-2DD0	6SE6400-3TC05-4DD0
6SE6440-2UC31-1DA1	15	80	125	ED4	6SE6400-3CC05-2DD0	6SE6400-3TC05-4DD0
6SE6440-2UC31-5DA1	20	100	125	ED4	6SE6400-3CC05-2DD0	6SE6400-3TC05-4DD0
6SE6440-2UC31-8EA1	25	110	125	ED4	6SE6400-3CC08-8EC0	6SE6400-3TC08-0ED0
6SE6440-2UC32-2EA1	30	125	125	ED4	6SE6400-3CC08-8EC0	6SE6400-3TC08-0ED0
6SE6440-2UC33-0FA1	40	175	250	FXD6	6SE6400-3CC11-7FD0	6SE6400-3TC15-4FD0
6SE6440-2UC33-7FA1	50	225	250	FXD6	6SE6400-3CC11-7FD0	6SE6400-3TC15-4FD0
6SE6440-2UC34-5FA1	60	250	250	FXD6	6SE6400-3CC11-7FD0	6SE6400-3TC15-4FD0

Table 2-11 Fuses, Circuit Breakers and Reactors for MM440 230V

Drive Part Number.	HP	Recommended Class J Fuse (Amps)	Circuit Breaker (Amps)	Circuit Breaker Type	Line Reactor	Output Reactor
3ph 460V Input						
6SE6440-2UD13-7AA1	½	3	15	ED4	6SE6400-3CC00-2AD3	6SE6400-3TC00-4AD2
6SE6440-2UD15-5AA1	¾	3	15	ED4	6SE6400-3CC00-2AD3	6SE6400-3TC00-4AD2
6SE6440-2UD17-5AA1	1	6	15	ED4	6SE6400-3CC00-4AD3	6SE6400-3TC00-4AD2
6SE6440-2UD21-1AA1	1 ½	6	15	ED4	6SE6400-3CC00-4AD3	6SE6400-3TC00-4AD2
6SE6440-2UD21-5AA1	2	6	15	ED4	6SE6400-3CC00-6AD3	6SE6400-3TC00-4AD2
6SE6440-2UD22-2BA1	3	10	15	ED4	6SE6400-3CC01-0BD3	6SE6400-3TC01-0BD3
6SE6440-2UD23-0BA1	4	15	15	ED4	6SE6400-3CC01-0BD3	6SE6400-3TC01-0BD3
6SE6440-2UD24-0BA1	5	20	30	ED4	6SE6400-3CC01-4BD3	6SE6400-3TC01-0BD3
6SE6440-2UD25-5CA1	7 ½	20	30	ED4	6SE6400-3CC02-2CD3	6SE6400-3TC03-2CD3
6SE6440-2UD27-5CA1	10	30	30	ED4	6SE6400-3CC02-2CD3	6SE6400-3TC03-2CD3
6SE6440-2UD31-1CA1	15	40	60	ED4	6SE6400-3CC03-5CD3	6SE6400-3TC03-2CD3
6SE6440-2UD31-5DA1	20	50	60	ED4	6SE6400-3CC04-4DD0	6SE6400-3TC05-4DD0
6SE6440-2UD31-8DA1	25	60	60	ED4	6SE6400-3CC04-4DD0	6SE6400-3TC03-8DD0
6SE6440-2UD32-2DA1	30	70	125	ED4	6SE6400-3CC05-2DD0	6SE6400-3TC05-4DD0
6SE6440-2UD33-0EA1	40	100	125	ED4	6SE6400-3CC08-3ED0	6SE6400-3TC08-0ED0
6SE6440-2UD33-7EA1	50	125	125	ED4	6SE6400-3CC08-3ED0	6SE6400-3TC07-5ED0
6SE6440-2UD34-5FA1	60	150	250	ED4	6SE6400-3CC11-2FD0	6SE6400-3TC14-5FD0
6SE6440-2UD35-5FA1	75	175	250	ED4	6SE6400-3CC11-2FD0	6SE6400-3TC15-4FD0
6SE6440-2UD37-5FA1	100	225	250	FXD6	6SE6400-3CC11-7FD0	6SE6400-3TC14-5FD0
6SE6440-2UD38-8FA1	125	300	400	FXD6	6SL3000-0CE32-3AA0	Consult Factory
6SE6440-2UD41-1FA1	150	350	500	FXD6	6SL3000-0CE32-8AA0	Consult Factory
6SE6440-2UD41-3GA1	200	400	500	JXD6	6SL3000-0CE33-3AA0	Consult Factory
6SE6440-2UD41-6GA1	250	450	600	LD6	6SL3000-0CE35-1AA0	Consult Factory
6SE6440-2UD42-0GA1	300	600	600	LD6	6SL3000-0CE35-1AA0	Consult Factory

Table 2-12 Fuses, Circuit Breakers and Reactors for MM440 460V

Drive Part Number.	HP	Recommended Class J Fuse (Amps)	Circuit Breaker (Amps)	Circuit Breaker Type	Line Reactor	Output Reactor
3ph 575V Input						
6SE6440-2UE17-5CA1	1	3	15	ED6	6SE6400-3CC00-4CE3	6SE6400-3TC01-8CE3
6SE6440-2UE21-5CA1	2	6	15	ED6	6SE6400-3CC00-4CE3	6SE6400-3TC01-8CE3
6SE6440-2UE22-2CA1	3	10	15	ED6	6SE6400-3CC00-8CE3	6SE6400-3TC01-8CE3
6SE6440-2UE24-0CA1	5	15	15	ED6	6SE6400-3CC00-8CE3	6SE6400-3TC01-8CE3
6SE6440-2UE25-5CA1	7 ½	20	30	ED6	6SE6400-3CC02-4CE3	6SE6400-3TC01-8CE3
6SE6440-2UE27-5CA1	10	20	30	ED6	6SE6400-3CC02-4CE3	6SE6400-3TC01-8CE3
6SE6440-2UE31-1CA1	15	25	30	ED6	6SE6400-3CC02-4CE3	6SE6400-3TC01-8CE3
6SE6440-2UE31-5DA1	20	40	60	ED6	6SE6400-3CC04-4DD0	6SE6400-3TC03-2DE0
6SE6440-2UE31-8DA1	25	50	60	ED6	6SE6400-3CC04-4DD0	6SE6400-3TC03-2DE0
6SE6440-2UE32-2DA1	30	60	60	ED6	6SE6400-3CC04-4DD0	6SE6400-3TC03-2DE0
6SE6440-2UE33-0EA1	40	80	125	ED6	6SE6400-3CC08-3ED0	6SE6400-3TC06-2FE0
6SE6440-2UE33-7EA1	50	100	125	ED6	6SE6400-3CC08-3ED0	6SE6400-3TC06-2FE0
6SE6440-2UE34-5FA1	60	110	250	FXD6	6SE6400-3CC11-2FD0	6SE6400-3TC06-2FE0
6SE6440-2UE35-5FA1	75	150	250	FXD6	6SE6400-3CC11-2FD0	6SE6400-3TC08-8FE0
6SE6440-2UE37-5FA1	100	175	250	FXD6	6SE6400-3CC11-2FD0	6SE6400-3TC08-8FE0

Table 2-13 Fuses, Circuit Breakers and Reactors for MM440 575V

NOTE

Refer to NEC code and fuse/breaker suppliers for additional selection information.

2.10 Power Cable Dimensions

Drive Part Number.	HP	Input Power Cable Dimensions (min) AWG	Input Power Cable Dimensions (max) AWG	Output Power Cable Dimensions (min) AWG	Output Power Cable Dimensions (max) AWG
1ph 230V Input					
6SE6440-2UC11-2AA1	1/6	16	14	16	14
6SE6440-2UC12-5AA1	1/3	16	14	16	14
6SE6440-2UC13-7AA1	1/2	16	14	16	14
6SE6440-2UC15-5AA1	3/4	16	14	16	14
6SE6440-2UC17-5AA1	1	16	14	16	14
6SE6440-2UC21-1BA1	1.5	16	10	16	10
6SE6440-2UC21-5BA1	2	16	10	16	10
6SE6440-2UC22-2BA1	3	14	10	16	10
6SE6440-2UC23-0CA1	4	12	8	16	8
3ph 230V Input					
6SE6440-2UC11-2AA1	1/6	16	14	16	14
6SE6440-2UC12-5AA1	1/3	16	14	16	14
6SE6440-2UC13-7AA1	1/2	16	14	16	14
6SE6440-2UC15-5AA1	3/4	16	14	16	14
6SE6440-2UC17-5AA1	1	16	14	16	14
6SE6440-2UC21-1BA1	1.5	16	10	16	10
6SE6440-2UC21-5BA1	2	16	10	16	10
6SE6440-2UC22-2BA1	3	16	10	16	10
6SE6440-2UC23-0CA1	4	16	8	16	8
6SE6440-2UC24-0CA1	5	14	8	12	8
6SE6440-2UC25-5CA1	7 ½	12	8	12	8
6SE6440-2UC27-5DA1	10	8	2	8	2
6SE6440-2UC31-1DA1	15	6	2	6	2
6SE6440-2UC31-5DA1	20	6	2	6	2
6SE6440-2UC31-8EA1	25	4	2	4	2
6SE6440-2UC32-2EA1	30	4	2	4	2
6SE6440-2UC33-0FA1	40	1	300MCM	1	300MCM
6SE6440-2UC33-7FA1	50	2/0	300MCM	2/0	300MCM
6SE6440-2UC34-5FA1	60	2/0	300MCM	3/0	300MCM

Table 2-14 Cable Dimensions 230V

Drive Part Number.	HP	Input Power Cable Dimensions (min) AWG	Input Power Cable Dimensions (max) AWG	Output Power Cable Dimensions (min) AWG	Output Power Cable Dimensions (max) AWG
3ph 460V Input					
6SE6440-2UD13-7AA1	½	16	14	16	14
6SE6440-2UD15-5AA1	¾	16	14	16	14
6SE6440-2UD17-5AA1	1	16	14	16	14
6SE6440-2UD21-1AA1	1 ½	16	14	16	14
6SE6440-2UD21-5AA1	2	16	14	16	14
6SE6440-2UD22-2BA1	3	16	10	16	10
6SE6440-2UD23-0BA1	4	16	10	16	10
6SE6440-2UD24-0BA1	5	16	10	16	10
6SE6440-2UD25-5CA1	7 ½	14	8	14	8
6SE6440-2UD27-5CA1	10	12	8	12	8
6SE6440-2UD31-1CA1	15	10	8	10	8
6SE6440-2UD31-5DA1	20	8	2	8	2
6SE6440-2UD31-8DA1	25	8	2	8	2
6SE6440-2UD32-2DA1	30	6	2	6	2
6SE6440-2UD33-0EA1	40	4	2	4	2
6SE6440-2UD33-7EA1	50	4	2	4	2
6SE6440-2UD34-5FA1	60	2	300MCM	2	300MCM
6SE6440-2UD35-5FA1	75	2/0	300MCM	2/0	300MCM
6SE6440-2UD37-5FA1	100	2/0	300MCM	3/0	300MCM
6SE6440-2UD38-8FA1	125	350MCM or 2*4/0	350MCM or 2*4/0	350MCM or 2*4/0	350MCM or 2*4/0
6SE6440-2UD41-1FA1	150	350MCM or 2*4/0	350MCM or 2*4/0	350MCM or 2*4/0	350MCM or 2*4/0
6SE6440-2UD41-3GA1	200	2* 500MCM	2*750MCM	2* 500MCM	2*750MCM
6SE6440-2UD41-6GA1	250	2* 500MCM	2*750MCM	2* 500MCM	2*750MCM
6SE6440-2UD42-0GA1	300	2* 500MCM	2*750MCM	2* 500MCM	2*750MCM

Table 2-15 Cable Dimensions 460V

Drive Part Number.	HP	Input Power Cable Dimensions (min) AWG	Input Power Cable Dimensions (max) AWG	Output Power Cable Dimensions (min) AWG	Output Power Cable Dimensions (max) AWG
3ph 575V Input					
6SE6440-2UE17-5CA1	1	16	6	16	6
6SE6440-2UE21-5CA1	2	16	6	16	6
6SE6440-2UE22-2CA1	3	16	6	16	6
6SE6440-2UE24-0CA1	5	16	6	16	6
6SE6440-2UE25-5CA1	7 ½	16	6	16	6
6SE6440-2UE27-5CA1	10	14	6	14	6
6SE6440-2UE31-1CA1	15	12	6	12	6
6SE6440-2UE31-5DA1	20	10	2	12	2
6SE6440-2UE31-8DA1	25	10	2	10	2
6SE6440-2UE32-2DA1	30	8	2	8	2
6SE6440-2UE33-0EA1	40	6	2	6	2
6SE6440-2UE33-7EA1	50	4	2	6	2
6SE6440-2UE34-5FA1	60	4	300MCM	4	300MCM
6SE6440-2UE35-5FA1	75	1	300MCM	2	300MCM
6SE6440-2UE37-5FA1	100	2/0	300MCM	1	300MCM

Table 2-16 Cable Dimensions 575V

3 50Hz / 60Hz Switch

CAUTION

This is a very critical step in the commissioning of a drive in North America.

On the MM440 there is a DIP switch that is used to select either 50Hz or 60Hz operation. This is referring to the nominal motor frequency being used.

The factory frequency setting (50Hz) can be adapted to NEMA frame motors (60Hz - typically used in North America) by using the DIP2(2) switch behind the I/O board.

At power up, the position of the DIP2(2) switch determines the setting of P0100, if P0100 = 0 / 1 then the DIP2(2) switch position has priority over the parameter value and will reset it according to the DIP2(2) position. If P0100 is set to 2 then the DIP2(2) switch is ignored.

After power cycling the drive following a change in DIP2(2) position, the parameters for the rated motor frequency (P0310), max. frequency (P1082) and reference frequency (P2000) are automatically pre-set to 50Hz/60Hz defaults (depending on switch position).

In addition, the rated motor parameters as well as all of the other parameters which depend on the rated motor parameters are reset. The units of the power parameters are, depending on P0100, either interpreted as kW value or hp value.

NOTE

Switch DIP2(1) behind the I/O board has no function.

DON'T FORGET THIS STEP

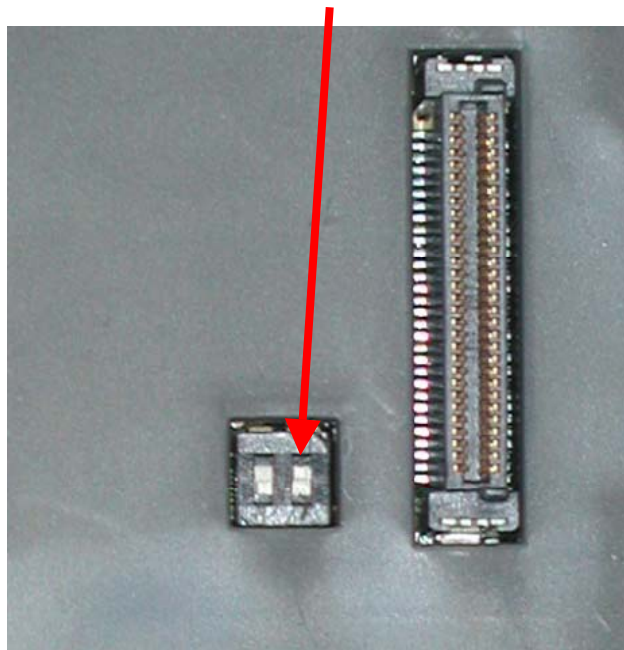

See section 3.1 for instructions

3.1 How to Remove I/O Card to Get At Switches

The 50/60Hz DIP switch is located underneath the I/O card on ALL frame sizes of MM440. In the top right hand corner of the I/O board there is a clip that can be released using a flat bladed screwdriver. Using the plastic bulge (over the relays on the I/O board), you can hold the I/O board and remove it easily once the clip has been released.

See following illustrations for instructions on removing the I/O boards in the different frame sizes.

3.1.1 Frame Size A to Frame Size C

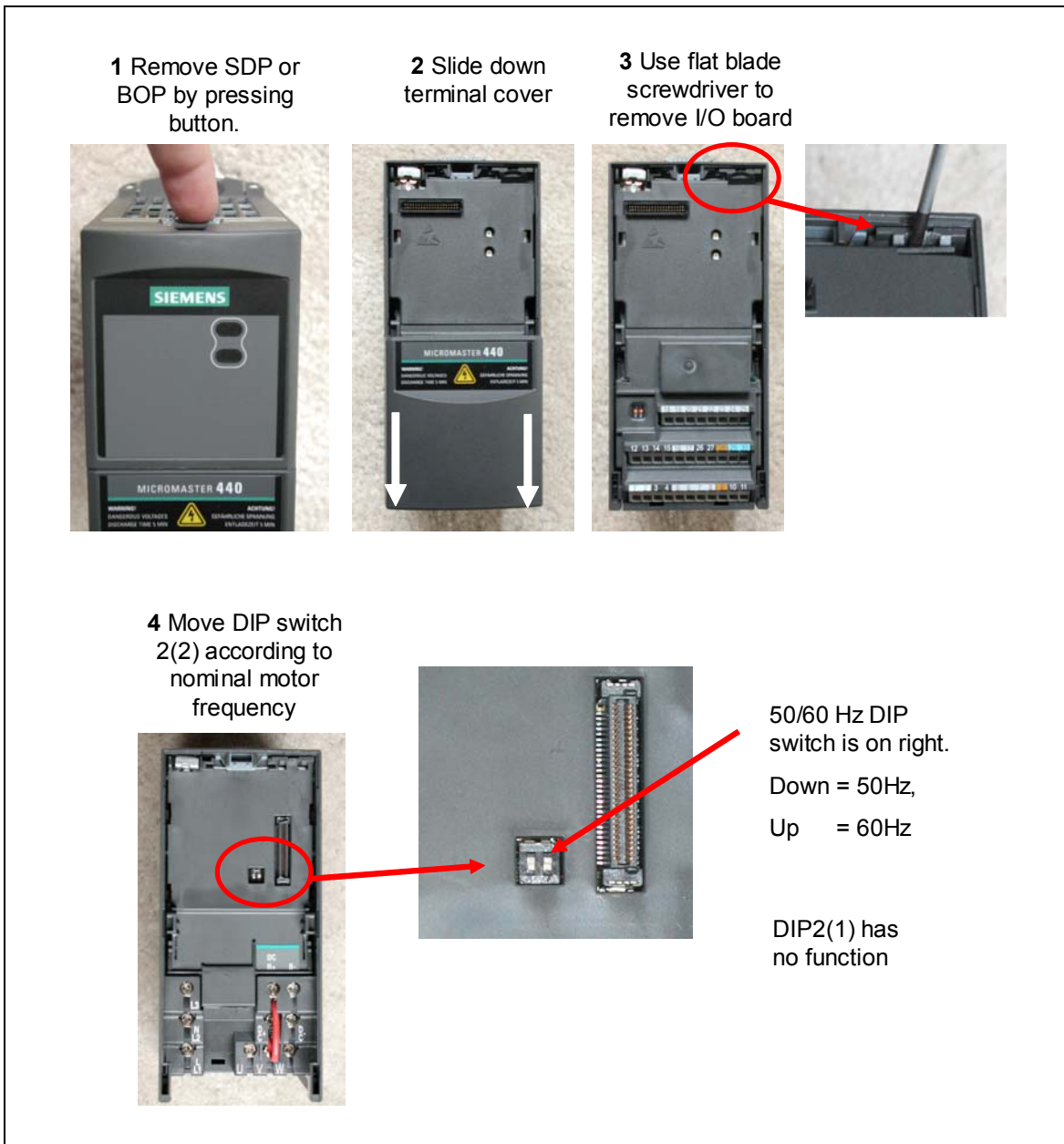

Figure 3-1 Removing the I/O board on Frame Size A to Frame Size C MM440

NOTE

Example shown is Frame Size A, Frame Size B & Frame Size C are similar.

3.1.2 Frame Size D to Frame Size F

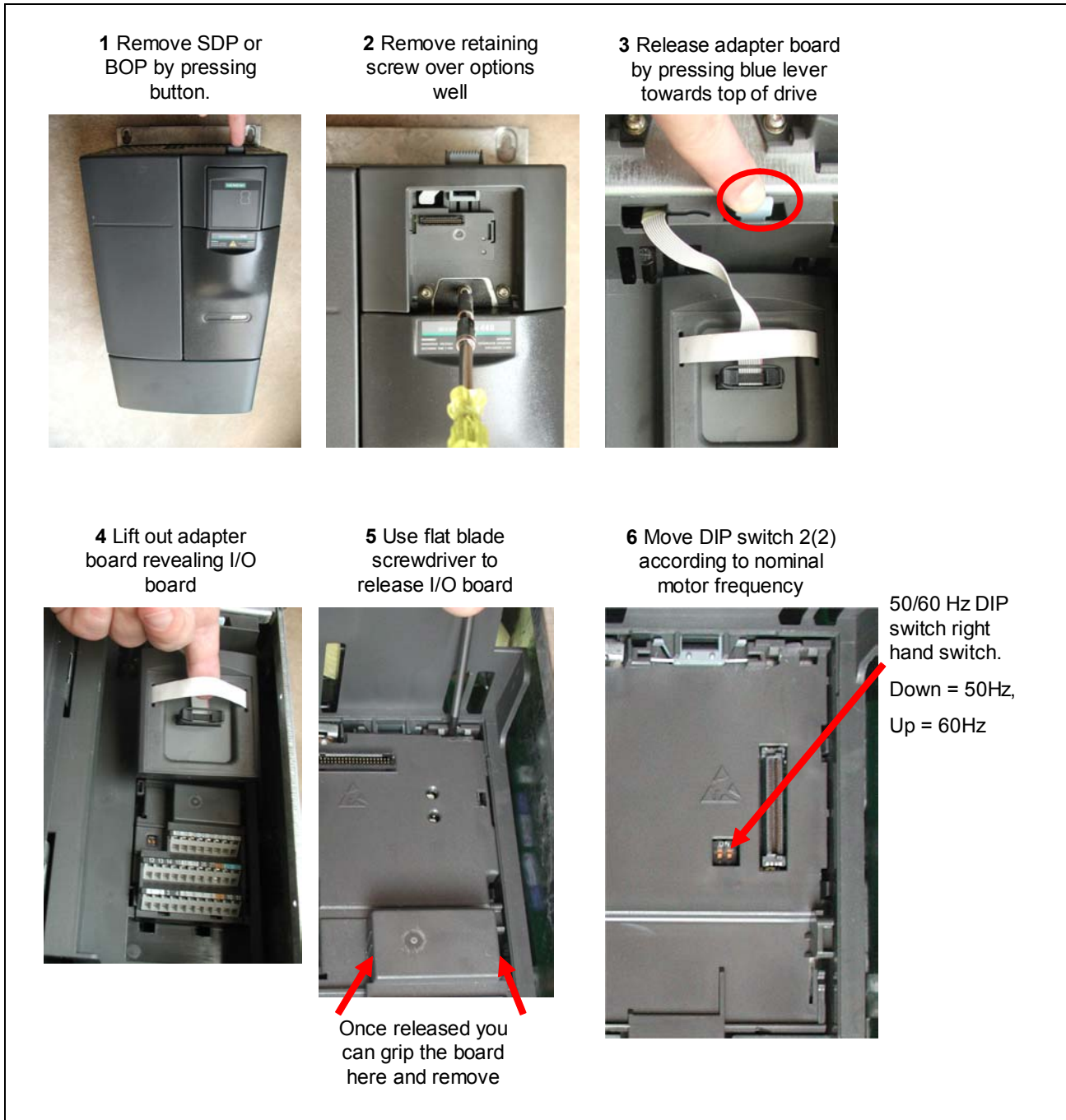

Figure 3-2 Removing the I/O board on Frame Size D to Frame Size F MM440

NOTE

Example shown is Frame Size D, Frame Size E & Frame Size F are similar.

3.1.3 Frame Size FX to Frame Size GX

For Frame Size FX & Frame Size GX, locate the I/O board and follow the same procedure as for Frame Size A.

4 Control Wiring

4.1 Control Block Diagram,

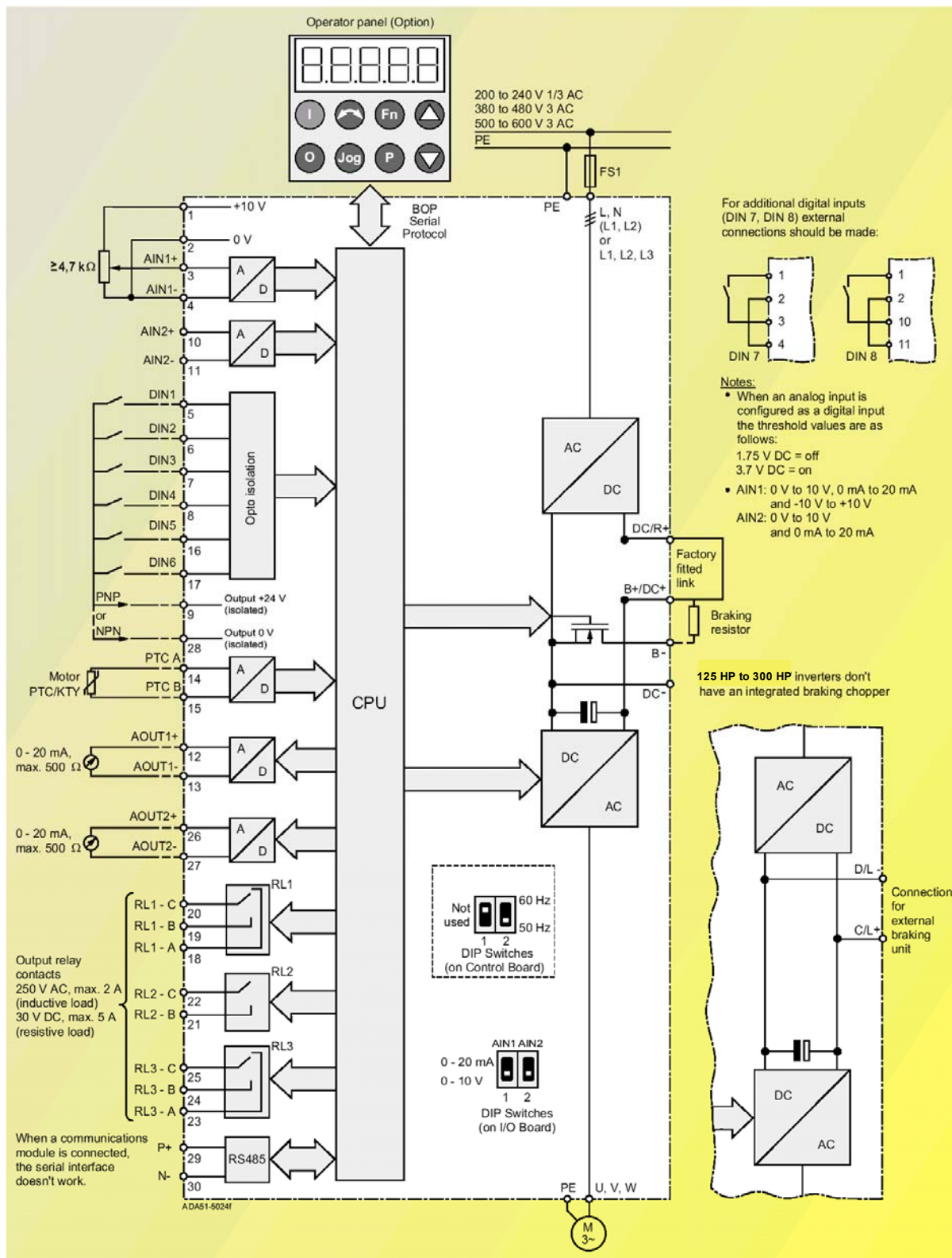

Figure 4-1 Control Wiring Block Diagram

4.2 Control Wiring Examples

Here are some wiring examples for your information.

On an MM440 it is important to do the commissioning in the correct order:

1. Power Cables,
2. 50/60Hz Switch
3. Control Wiring
4. Quick Commissioning
5. Other Parameters

Some example parameter settings are shown next to each picture below.

NOTE

If quick commissioning is performed after these settings shown below then the settings may be overwritten.

Default Control Wiring

Parameter Settings:
Make these changes **AFTER** quick commissioning: see section 5.5 on page 42

Default settings are shown. No parameter changes are needed after Quick Commissioning

DIP SW 1 (Analog Input 1)	DIP SW 2 (Analog Input 2)
ON (UP) = 0 to 20mA OFF = 0 to 10V	ON (UP) = 0 to 20mA OFF = 0 to 10V

Default control settings:
Setpoint via the AIN 1, (0-10V)
RUN command via DIN 1,
REVERSE command via DIN 2,
RESET via DIN 3,
Output frequency via AOUT 1,
Fault messages via RL1,
Warnings via RL2.

0/4 – 20mA – Current Input

Parameter Settings:

Make these changes **AFTER** quick commissioning: see section 5.5 on page 42

0-20mA

P0003=3 (Expert)
 P0756[0]=2 (AIN1 – Current)
 P0756[1]=2 (AIN2 – Current)

Make these additional changes for **4-20mA**

P0757[0]=4 (AIN1 min 4mA)
 P0757[1]=4 (AIN2 min 4mA)
 P0761[0]=4 (AIN1 Deadband)
 P0761[1]=4 (AIN2 Deadband)

NOTE:

Index [0] is AIN1, Index [1] is AIN2, so if you are only using 1 Analog Input then you only need to change those indices.

DIP SW 1 (Analog Input 1)	DIP SW 2 (Analog Input 2)
ON (UP) = 0 to 20mA OFF = 0 to 10V	ON (UP) = 0 to 20mA OFF = 0 to 10V

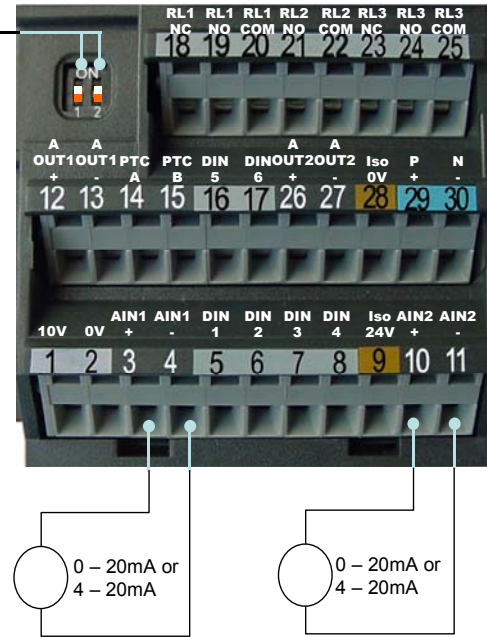

0 to 10V (Voltage Input)

Parameter Settings:

Make these changes **AFTER** quick commissioning: see section 5.5 on page 42

These are the default settings as shown. No parameter changes are necessary other than quick commissioning.

DIP SW 1 (Analog Input 1)	DIP SW 2 (Analog Input 2)
ON (UP) = 0 to 20mA OFF = 10V	ON (UP) = 0 to 20mA OFF = 0 to 10V

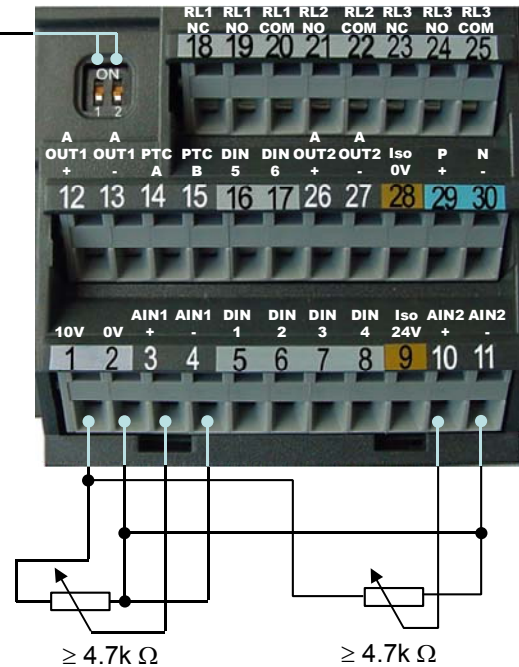

2-Wire Control

Parameter Settings:

Make these changes **AFTER** quick commissioning: see section 5.5 on page 42

These are the default settings as shown. No parameter changes are necessary other than quick commissioning.

DIP SW 1 (Analog Input 1)	DIP SW 2 (Analog Input 2)
ON (UP) = 0 to 20mA OFF = 0 to 10V	ON (UP) = 0 to 20mA OFF = 0 to 10V



When switch is closed, drive will RUN, it will STOP when switch is opened

RUN/STOP
Switch

3-Wire Control (Using BICO for Latching)

Parameter Settings:

Make these changes **AFTER** quick commissioning: see section 5.5 on page 42

- P0003=3 (Expert)
- P0700[0]=2
- P0701[0]=99 (BICO)
- P0702[0]=99 (BICO)
- P0840[0]=2841 (output of RS Flip Flop 1)
- P0844[0]=722.1
- P2800=1 (Enable FFBs)
- P2801[9]=1 (Enable NOT1)
- P2801[14]=1 (Enable RS FF1)
- P2828=722.1 (Invert DIN2)
- P2840[0]=722.0 (Set)
- P2840[1]=2829.0 (Reset)

NOTE:

This method works by creating a latch from a flip flop. It is set from DIN1 and reset from DIN2

Wiring when BICO performs the "latching" process

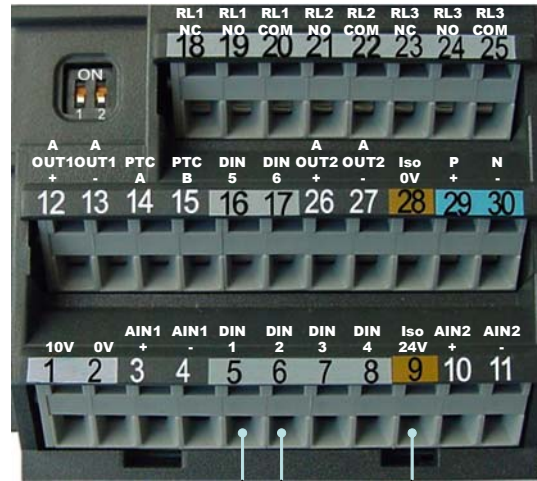

STOP
Normally Closed Push Button
(Momentary Action)

START
Normally Open Push Button
(Momentary Action)

STOP
START

3-Wire Control (Using Relay 1 for Latching)

Parameter Settings:

Make these changes **AFTER** quick commissioning: see section 5.5 on page 42

- P0003=2 (Extended)
- P0700[0]=2 (Terminals)
- P0701[0]=1 (DIN1=Start)
- P0702[0]=3 (DIN2=OFF2)
- P0731=52.2 (Drive Running)

NOTE:

This method works by locking in the START signal using a relay.

Wiring when Relay 1 performs the "latching" process

STOP
Normally Closed Push Button (Momentary Action)

START
Normally Open Push Button (Momentary Action)

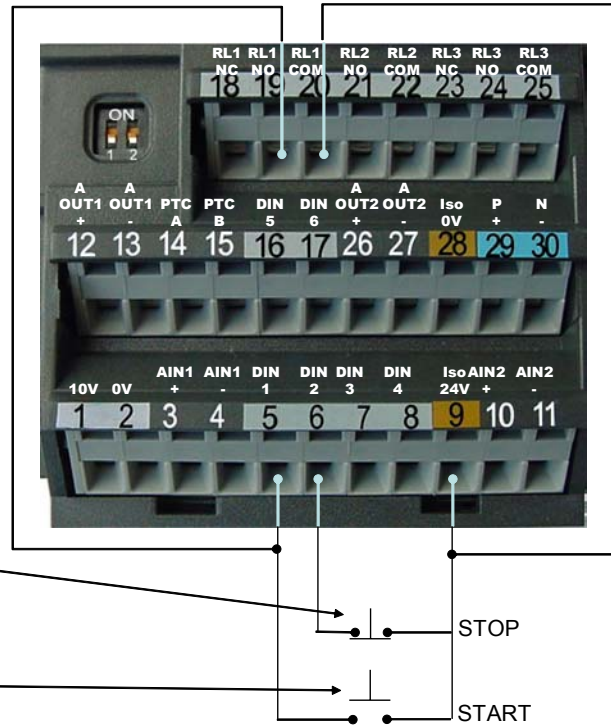

Hand Off Auto (HOA)

Parameter Settings:

Make these changes **AFTER** quick commissioning: see section 5.5 on page 42

- P0003=3 (Expert)
- P0700[0]=2 (Auto/OFF)
- P0700[1]=1 (Hand)
- P0700[2]=2 (Auto)
- P0701[0,1,2]=99 (BICO)
- P0702[0,1,2]=0 (disabled)
- P0703[0,1,2]=99 (BICO)
- P0704[0]=0 (disabled)
- P0704[1]=0 (disabled)
- P0704[2]=1 (Run/Stop)
- P0810=722.0 (DIN1-Hand)
- P0811=722.2 (DIN3-Auto)
- P1000[0]=2 (AIN1)
- P1000[1]=1 (BOP/MOP)
- P1000[2]=2 AIN1)

DIP SW 1 (Analog Input 1)	DIP SW 2 (Analog Input 2)
ON (UP) = 0 to 20mA OFF = 0 to 10V	ON (UP) = 0 to 20mA OFF = 0 to 10V

HAND =
BOP – RUN/STOP
BOP – Setpoint

AUTO =
DIN4 – RUN/STOP
AIN1 = Setpoint

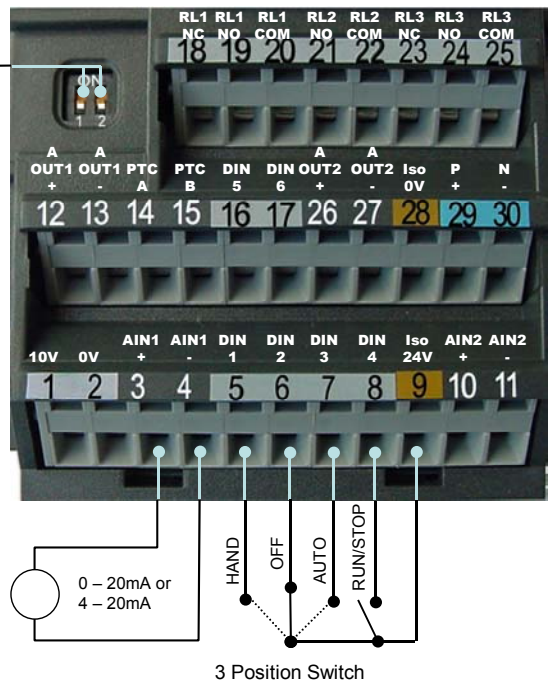

Externally Supplied Control Voltage

Parameter Settings:

Make these changes **AFTER** quick commissioning: see section 5.5 on page 42

These are the default settings as shown. No parameter changes are necessary other than quick commissioning.

DIP SW 1 (Analog Input 1)	DIP SW 2 (Analog Input 2)
ON (UP) = 0 to 20mA OFF = 0 to 10V	ON (UP) = 0 to 20mA OFF = 0 to 10V

It is necessary for the 0V from the external system to be connected to the 0V on the drive to complete the circuit.

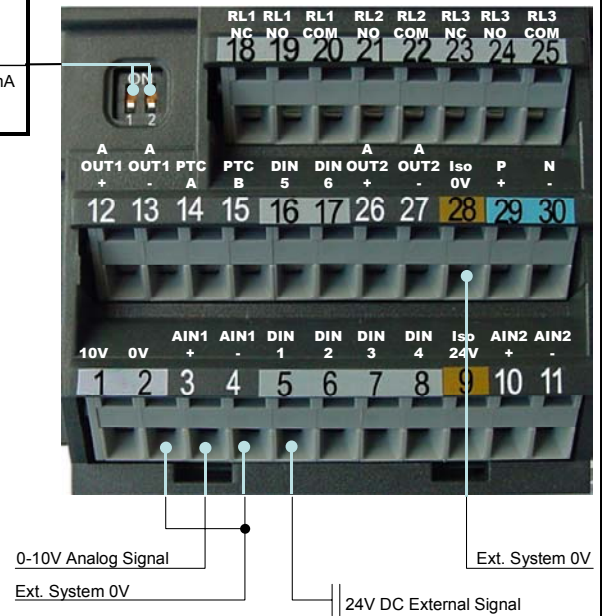

Using Fixed Frequencies

Parameter Settings:

Make these changes **AFTER** quick commissioning: see section 5.5 on page 42

P0003=2 (Extended)
P0703[0]=15 DIN3=FF3
P1000[0]=3 (Fixed Frequency)
P1003[0]=FF3
P1004[0]=FF4

DIP SW 1 (Analog Input 1)	DIP SW 2 (Analog Input 2)
ON (UP) = 0 to 20mA OFF = 0 to 10V	ON (UP) = 0 to 20mA OFF = 0 to 10V

This example gives you 2 fixed frequencies in either direction.
If both Fixed Frequencies are selected together then the sum of P1003 and P1004 will be the setpoint.
This may be limited by FMAX/FMIN

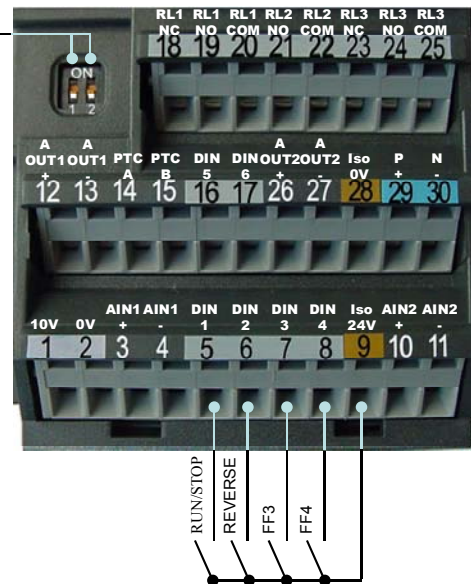









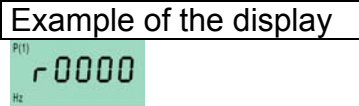

5 Setting Parameters

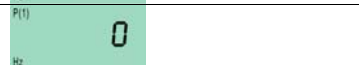
5.1 Introduction to Basic Operator Panel (BOP).











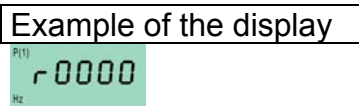







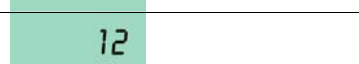

There are several types of parameters that can be changed on a MICROMASTER 440. This procedure describes how to use the BOP to change parameters. There are also read-only parameters denoted by rXXXX for information/monitoring purposes.

5.1.1 Changing a “normal” parameter.

Step	Example of the display
1 Press  in order to access list of parameters.	
2 Press  to select the parameter that you want to change.	
3 Press  to access that parameter's contents	
4 Press  or  to scroll to desired setting	
5 Press  to confirm and save the setting	
6 Repeat steps 1 to 5 until all desired parameters are changed	

NOTE: In this example, the user can only see the command parameters.

5.1.2 Changing an indexed parameter

Step	Example of the display
1 Press  in order to access list of parameters.	
2 Press  to select the parameter that you want to change.	
3 Press  in order to reach the index number	
Press  or  in order to scroll to the required index	
4 Press  in order to display the current setting	
5 Press  or  to scroll to desired setting	
6 Press  to confirm and save the setting	
7 Press  or  to scroll to next desired parameter & repeat steps 2 to 6	
8 Press  to scroll back down to r0000	
9 Press  to exit the parameter changing menu	

NOTE

The 3rd type of parameter is a “bit” parameter. For further information on this, see the operating instructions.

NOTE

The BOP sometimes display **buSY** when changing parameter values. This means that the drive is presently handling another higher priority task.

5.2 Factory Reset

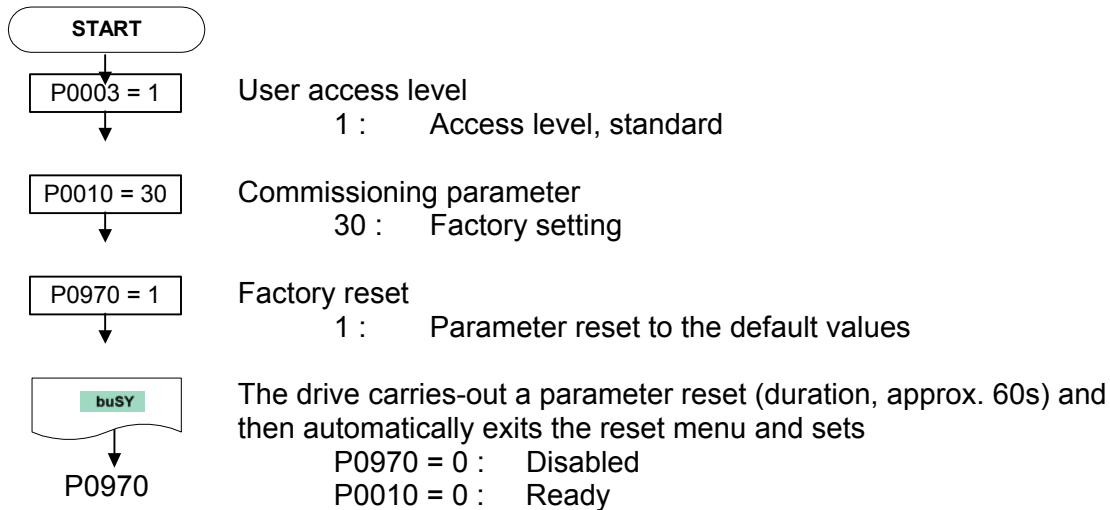
**NOTE**

When resetting the parameters to the factory setting, the communications memory is re-initialized. This means that communications via USS in addition to the PROFIBUS / DeviceNet / CanBus CB board are interrupted during the reset:

The "busy" text is displayed on the BOP during the parameter reset.

After reset has been completed, communications are automatically re-established when using STARTER, DriveMonitor or the BOP.

5.3 Commissioning an MM440

In quick commissioning you set all of the basic parameters necessary to get your motor turning. The user must obtain all motor data information from the name plate on the motor before beginning this process.

Here is some information about how to read the parameter data from the name plate:

5.4 Reading Motor Name Plates

5.4.1 NEMA Motor

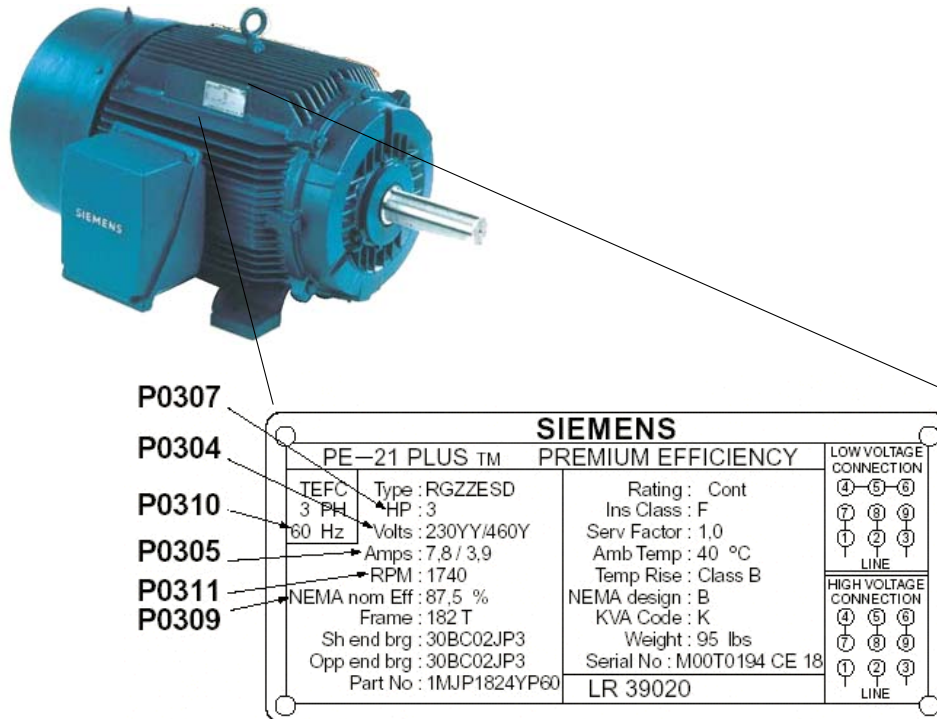

Figure 5-1 Reading NEMA Motor Name Plate

5.4.2 IEC motor.

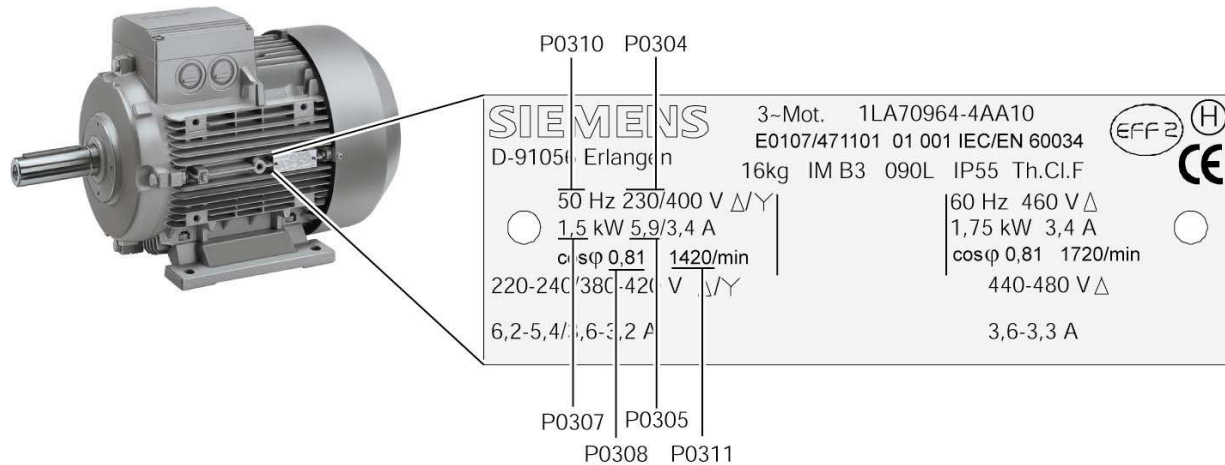

Figure 5-2 Reading IEC Motor Name Plate

5.5 Level 3 Quick Commissioning

Parameters, designated with a * offer more setting possibilities than are actually listed here. Refer to the parameter list on the supplied CD for additional setting possibilities.

Correct Motor information is very important – please refer to section 5.4 for detailed information. For multi-motor (parallel motors) please see the operating instructions for further details.

Parameters with “[0]” after the number are referring to index 0 of that parameter. For example, if you read P0300[0]=1 it means that you should set P0300 index 0 to a 1.

You can enter your own settings in the user settings column for quick reference

Parameter Number	Parameter Description	Suggested Setting	User Setting
P0003	<p>Set User Access Level *</p> <p>1 Standard 2 Extended 3 Expert</p>	3	
P0010	<p>Start Quick Commissioning *</p> <p>0 Ready 1 Quick commissioning 30 Factory setting (refer to section 5.2)</p> <hr/> <p>NOTE</p> <p>P0010 must be set to 1 in order to parameterize the motor data.</p>	1	
P0100	<p>Check/Set Frequency Setting (50/60Hz)</p> <p>0 USE DIP2(2) Switch - 50Hz, kW (typically European IEC Motors) 1 USE DIP2(2) Switch - 60 Hz, HP (typically North American NEMA frame motors) 2 60 Hz, kW (Typically found in Asian market)</p> <hr/> <p>IMPORTANT NOTE:</p> <p>For P0100 = 0 or 1, the setting of switch DIP2(2) (under I/O board) determines the value of P0100 (refer to the parameter list):</p> <p style="text-align: center;">OFF = kW, 50 Hz ON = HP, 60 Hz</p> <p>If P0100 does not correctly reflect your motor data (50/60Hz) at this point, please power down your MICROMASTER and change the DIP2(2) switch according to section 3 before continuing.</p> <p>Failure to follow this procedure will result in complete loss of your motor parameters at the next power cycle.</p>	<p>According to motor</p> <p>usually a “1” should be set using the DIP2(2) switch in the USA</p>	

Parameter Number	Parameter Description	Suggested Setting	User Setting
P0205	<p>Set Inverter Application</p> <p>0 Constant torque (e.g. compressors, conveyors) 1 Variable torque (e.g. pumps, fans)</p> <hr/> <p>NOTE This parameter switches you between the Constant Torque and Variable Torque rating on an MM440 drive – where applicable.</p> <p>This parameter is only usable for 3ph input inverters Frame Size C and larger. On smaller units it is not changeable.</p>	0	
P0300[0]	<p>Select Motor Type</p> <p>1 Asynchronous motor (induction motor) 2 Synchronous motor</p> <hr/> <p>NOTE For P0300 = 2 (synchronous motor), only the V/f control types (P1300 < 20) are permitted.</p> <p>Some features are not available if you have a synchronous motor – please refer to Parameter List document for complete information</p>	1	
P0304[0]	<p>Enter Rated Motor Voltage (enter value from motor name plate)</p> <hr/> <p>NOTE The rated motor voltage on the name plate must be checked, regarding the Wye(star)/delta circuit configuration to ensure that it matches with the circuit connection configured at the motor terminal board.</p>	From Name Plate	
P0305[0]	<p>Enter Rated Motor Current (enter value from motor name plate)</p>	From Name Plate	
P0307[0]	<p>Enter Rated Motor Power (enter value from motor name plate)</p> <p>If P0100 = 0 or 2, the entry is in kW and for P0100 = 1, in hp.</p>	From Name Plate	
P0308[0]	<p>Enter Rated Motor CosPhi (Power Factor) (enter value from motor name plate)</p> <p>If the setting is 0, the value is automatically calculated.</p> <hr/> <p>NOTE You will not see this parameter on your BOP if P0100=1 This is NOT the service factor (cos φ value is always<1)</p>	From Name Plate	

Parameter Number	Parameter Description	Suggested Setting	User Setting
P0309[0]	<p>Enter Rated Motor Efficiency (enter value from motor name plate) If the setting is 0, the value is automatically calculated.</p> <hr/> <p>NOTE You will not see this parameter in your BOP or AOP if P0100=0. Always enter the value from the motor name plate if you have it. If this figure is calculated too low then you may trip on F0041 (Motor ID Failure) or F0011 (Motor Overtemperature).</p>	From Name Plate	
P0310[0]	<p>Enter Rated Motor Frequency (enter value from motor name plate)</p> <hr/> <p>NOTE Typically this will already have been set by the DIP2(2) switch, however if you have a non-standard motor, here is where you enter the nominal frequency. The number of pole pairs is automatically calculated</p>	From Name Plate	
P0311[0]	<p>Enter Rated Motor Speed (enter value from motor name plate) If the setting is 0, the value is internally calculated.</p> <hr/> <p>NOTE An entry <u>must</u> be made for closed-loop Vector control, V/f control with FCC and for slip compensation.</p>	From Name Plate	
P0335[0]	<p>Enter Motor Cooling Method*</p> <p>0 Self-cooled using shaft mounted fan attached to the motor 1 Force-cooled: Using a separately powered cooling fan</p>	0	
P0500[0]	<p>Enter Technological Application</p> <p>0 Constant Torque 1 Pumps and Fans 3 Simple Positioning</p> <hr/> <p>NOTE See P0205</p>	0	
P0640[0]	<p>Enter Motor Overload Factor</p> <p>This defines the limit of the maximum output current as a % of the rated motor current (P0305). This parameter is set, using P0205 for constant torque, to 150 %, and for variable torque, to 110 %.</p>	150	

Parameter Number	Parameter Description	Suggested Setting	User Setting
P0700[0]	<p>Select of Command Source (Start/Stop)*</p> <p>0 Resets the digital I/O to the factory default setting 1 BOP (drive inverter keypad) 2 Terminal strip (factory default setting) 4 USS on BOP link (RS232) 5 USS on COM link (via control terminals 29 and 30) 6 CB on COM link(CB = communications module)</p> <hr/> <p>NOTE Changing the setting of P0700 will result in all Digital inputs and outputs being reset to their defaults for that setting. See Parameter List for full details.</p>	2	
P1000[0]	<p>Select of Frequency Setpoint Source *</p> <p>1 Motorized potentiometer setpoint (MOP setpoint) 2 Analog input (factory default setting) 3 Fixed frequency setpoint 4 USS on BOP link 5 USS on COM link (control terminals 29 and 30) 6 CB on COM link (CB = communications module) 7 Analog input 2</p>	2	
P1080[0]	<p>Set Min. Frequency</p> <p>Enters the lowest motor frequency with which the motor operates independently of the frequency setpoint. The value which is set here applies for both directions of rotation.</p>	0	
P1082[0]	<p>Set Max. Frequency</p> <p>Enters the maximum frequency to which, for example, the motor is limited independently of the frequency setpoint. The value which is set here applies for both directions of rotation.</p> <hr/> <p>NOTE You should check with your motor manufacture if you intend to operate above nominal motor frequency. Lifetime and/or safety could be compromised if you go too fast.</p>	60	
P1120[0]	<p>Set Ramp-Up Time</p> <p>Enters the time with which, for example, the motor should accelerate from standstill up to the maximum frequency P1082. If the ramp-up time is set too low, this may result in alarm A0501 (current limit active) or the drive tripping out with fault F0001 (overcurrent).</p>	10	

Parameter Number	Parameter Description	Suggested Setting	User Setting
P1121[0]	<p>Set Ramp-Down Time</p> <p>Enters the time with which, for example, the motor should brake from the maximum frequency P1082 down to standstill. If the ramp-down time is set too low, then this may result in alarms A0501 (current limit active), A0502 (overvoltage limit active) or the drive tripping with fault F0001 (overcurrent) or F0002 (overvoltage).</p>	10	
P1135[0]	<p>Set OFF 3 Ramp-Down Time</p> <p>Enters the time with which, for example, the motor should brake from the maximum frequency P1082 down to standstill with an OFF3 Command (Fast Stop). If the ramp-down time is set too low, then this may result in alarms A0501 (current limit active), A0502 (overvoltage limit active) or the drive tripping with fault F0001 (overcurrent) or F0002 (overvoltage).</p>	5	
P1300[0]	<p>Select Control Mode</p> <p>0 V/f with linear characteristic 1 V/f with FCC 2 V/f with parabolic characteristic 5 V/f for textile applications 6 V/f with FCC for textile applications 19 V/f control with independent voltage setpoint 20 Sensorless Vector control ** 21 Vector control with sensor ** 22 Sensorless Vector torque-control ** 23 Vector torque-control with sensor **</p> <hr/> <p>NOTE ** See Parameter List document for further information on any non-V/f control mode.</p>	0	
P1500[0]	<p>Select Torque Setpoint *</p> <p>0 No main setpoint 2 Analog setpoint 4 USS on BOP link 5 USS on COM link (control terminals 29 and 30) 6 CB on COM link (CB = communications module) 7 Analog setpoint 2</p>	0	
	<p>WARNING</p> <p>The motor data identification routine must not be used for loads which are potentially hazardous (e.g. suspended loads for crane applications). Before the motor data identification run is started, the potentially hazardous load must be carefully secured (e.g. by lowering the load to the floor or by clamping the load using a motor holding brake).</p>		

Parameter Number	Parameter Description	Suggested Setting	User Setting
P1910	<p>Select Motor Data Identification *</p> <p>0 Disabled</p> <p>1 Identification of all parameters with parameter change. These are accepted and applied to the controller.</p> <p>2 Identification of all parameters without parameter change. These are displayed but are not applied to the controller.</p> <p>3 Identification of saturation curve with parameter change.</p> <hr/> <p>NOTE Alarm A0541 (motor data identification active) is generated, and a measurement is made at the next ON command.</p>	1	
P3900	<p>End Quick Commissioning</p> <p>0 No quick commissioning (no motor calculations)</p> <p>1 Motor calculation and reset all non Quick Commissioning parameters to factory setting.</p> <p>2 Motor calculation and reset of the I/O settings to the factory setting.</p> <p>3 Only motor calculation. The other parameters are not reset.</p>	1	

The following describes the sequence of events after setting P3900 to a 1:

1. **buSY** is displayed. This means that the control data is being calculated and is then copied, together with the parameters, from the RAM into the ROM. After quick commissioning has been completed, P3900 is re-displayed.

NOTE

Do not disconnect from the line supply until the motor data identification has been completed and P3900 is re-displayed. Parameter P1910 will not be saved if drive is prematurely disconnected.

2. Start motor data identification

NOTE

The motor data identification routine is started using the ON command (factory setting DIN1).

This can take **several** minutes depending on the size of the motor. Large motors take longer than small motors.

Current flows through the motor and the rotor aligns itself. After motor data identification has been completed, data is copied from the RAM into the ROM whereby **buSY** is displayed. Alarm A0541 (motor data identification active) is automatically reset and P3900 is re-displayed.

3. QUICK COMMISSIONING IS NOW FINISHED.

NOTE

If you are going to run in Vector mode or Sensorless Vector mode then refer to the Operating Instructions for further information.

5.6 Checking Direction of Motor Rotation



WARNING

The following procedures require the motor to rotate. Ensure that the area is safe around the moving parts before energizing the system. Failure to observe this precaution could result in severe bodily injury or loss of life.

1. At this point you should “bump” (rotate) your motor if your application allows it.
2. Apply a RUN command and check that the motor is rotating in the correct direction.

If it is rotating in the wrong direction:

- a) Swap any 2 of the motor leads over OR
- b) Set P0003=2, then set P1820=1 - (this may save some time on a larger unit where it can be difficult to change the wiring).

5.7 Parameter Filter Function

There are many different parameters that can be found on the MM440 drive giving it a unique flexibility. In order to make it easier to find the parameters that you are looking for, they can be arranged according to functionality. P0004 is the parameter that you can use to “filter” or “group” the parameters according to this functionality.

Table 5.3 below shows these functional groups.

Grouping	Parameter P0004 Setting	Description	Parameter Ranges
ALWAYS	0	All parameters	0000 to 3900
INVERTER	2	Drive related parameters	0200 to 0299
MOTOR	3	Motor parameters	0300 to 0399 and 0600 to 0699
ENCODER	4	Encoder	0400 to 0499
TECH_APL	5	Technical applications / units	0500 to 0599
COMMANDS	7	Control commands, digital I/O	0700 to 0749 and 0800 to 0899
TERMINAL	8	Analog inputs/outputs	0750 to 0799
SETPOINT	10	Setpoint channel and ramp-function gen.	1000 to 1199
FUNC	12	Drive inverter functions	1200 to 1299
CONTROL	13	Motor open-loop/closed-loop control	1300 to 1799
COMM	20	Communications	2000 to 2099
ALARMS	21	Faults, warnings, monitoring functions	2100 to 2199
TECH	22	PID controller, free blocks	2200 to 2399 and 2800 ... 2890

Table 5-3 Parameter Locations

Please refer to the Parameter List document for further information on these groupings.

5.8 Setting up Inputs and Outputs,

5.8.1 Digital inputs (DIN)

Parameter range	r0701 – P0725
Features:	
Quantity	6
Cycle time	2 ms
Switch-on threshold	13.6 V
Switch-off threshold	10.6 V
Electrical features	electrically isolated, short-circuit proof
Function chart number	FP2000, FP2200 (in parameter list)

Table 5-4 Digital Input Specification

External control signals are required for a drive to be able to operate. These signals can be entered through the serial interface as well as using digital inputs.

MICROMASTER 440 has 6 digital inputs which can be expanded to a total of 8 by using the 2 analog inputs. The digital inputs can be freely programmed to create a function. It is possible to directly assign a pre-designed function using parameters P0701 - P0708 or to build your own function using BICO technology.

This document will only cover the use of the pre-designed functionality.

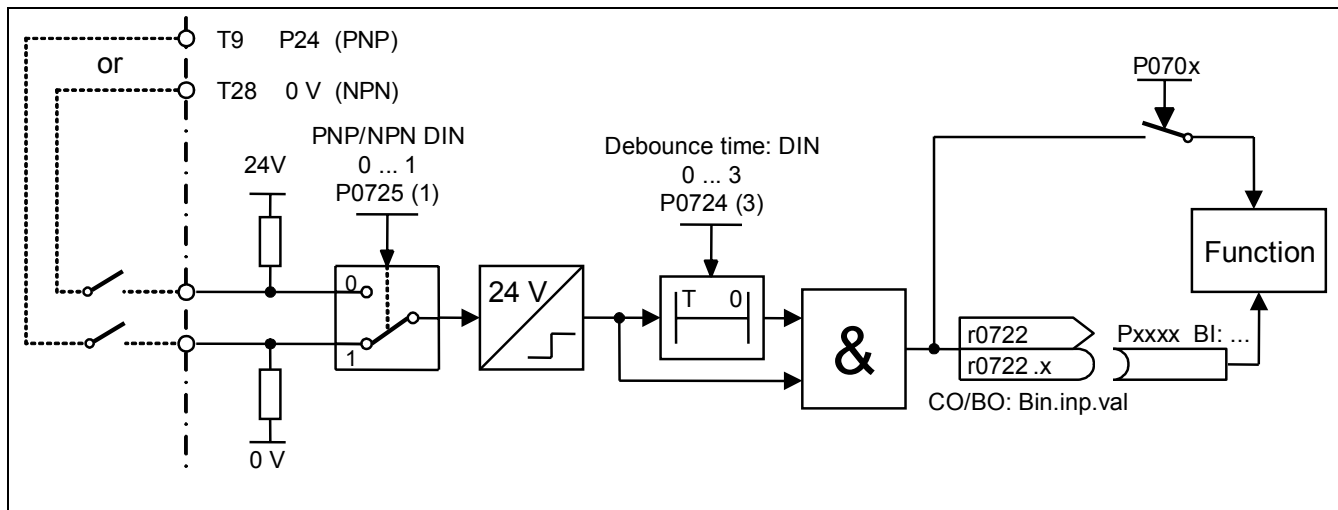

Figure 5-5 Digital Inputs Function Diagram

The diagram above illustrates that you have external switches. You choose whether the signals are active high or active low (P0725). You choose the de-bounce time to filter out noisy switches (P0724), you then assign a function to that input according to the table 5.8 below (P0701-P0708);

NOTE

r0722 is a digital representation of the status of the 6 (+2) digital inputs – this parameter should be used to check that your signals are coming through to the drive.

Please refer to the troubleshooting section for information on how to use r0722.

Parameters P0701 – P0706 (P0707 – P0708)

Parameter value	Function
0	Digital input disabled
1	ON / OFF1
2	ON+reverse / OFF1
3	OFF2 – coast to standstill
4	OFF3 – quick ramp-down
9	Fault acknowledge
10	JOG right
11	JOG left
12	Reverse
13	MOP up (increase frequency)
14	MOP down (decrease frequency)
15	Fixed setpoint (direct selection)
16	Fixed setpoint (direct selection + ON)
17	Fixed setpoint (binary-coded selection + ON)
25	Enable DC braking
29	External trip
33	Disable additional frequency setpoint
99	Enable BICO parameterization

Table 5-6 Standard Selectable Functions for Digital Inputs

NOTE

If an analog input has been configured as digital input, then the following limit values apply:
 < 1.7 V DC = "0", > 3.9 V DC = "1"

BICO parameterization

If the available settings above are not sufficient for your application, then refer to the operating instructions and parameter lists for comprehensive information about BICO parameterization.

NOTE

Only experienced users should use the BICO parameterization and for applications where the possibilities provided by P0701 – P0708 are no longer adequate.

5.8.2 Analog inputs (ADC)

Parameter range	P0750 – P0762
Features:	
Quantity	2
Cycle time	4 ms
Resolution	10 bits
Accuracy	1% of full scale (10V or 20mA)
Electrical features	Polarity protection, short-circuit proof
Function chart number	FP2200 (in parameter list)

Table 5-7 Analog Input Specifications

Analog signals are converted to digital signals inside the drive using Analog to Digital Converters.

The user must select either Voltage (default) or Current using the 2 switches on the I/O board DIP1(1,2). Additionally, P0756 must also be set accordingly.

Example using voltage input

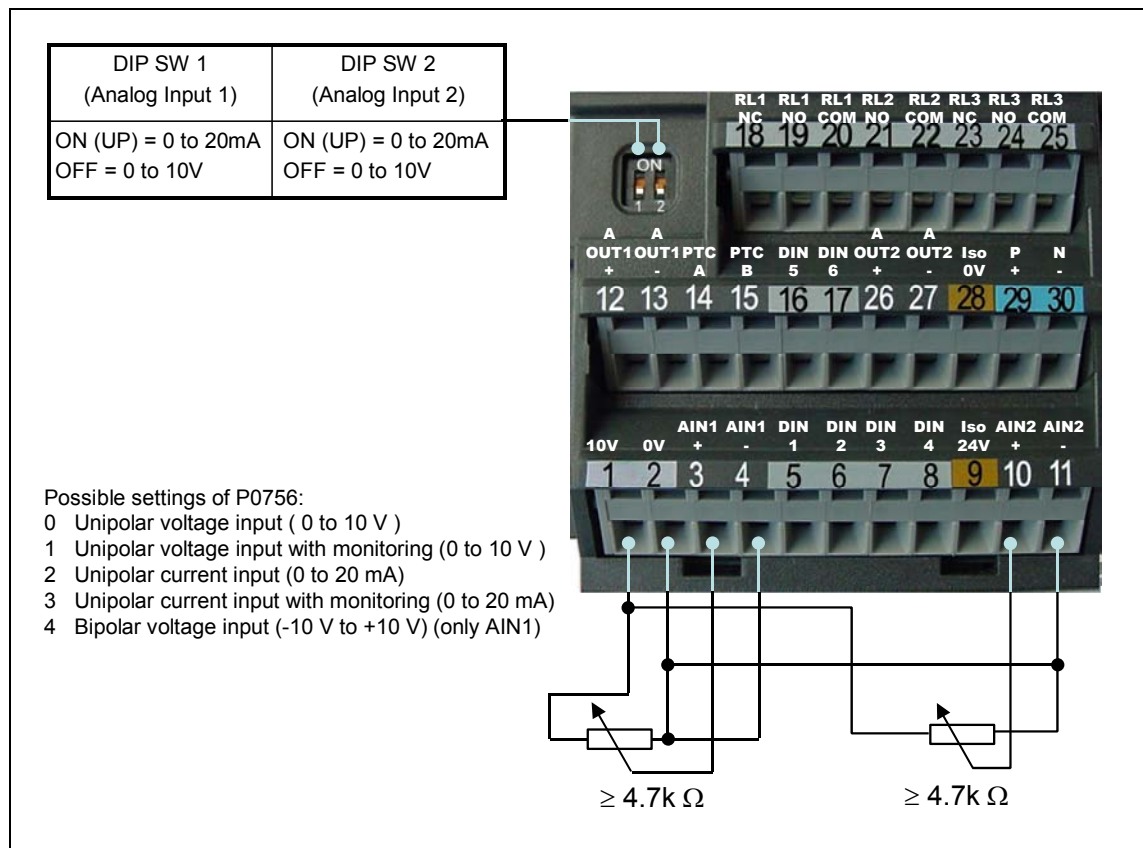

Figure 5-8 DIP Switch And P0756 for Analog Voltage Input

Example using current input

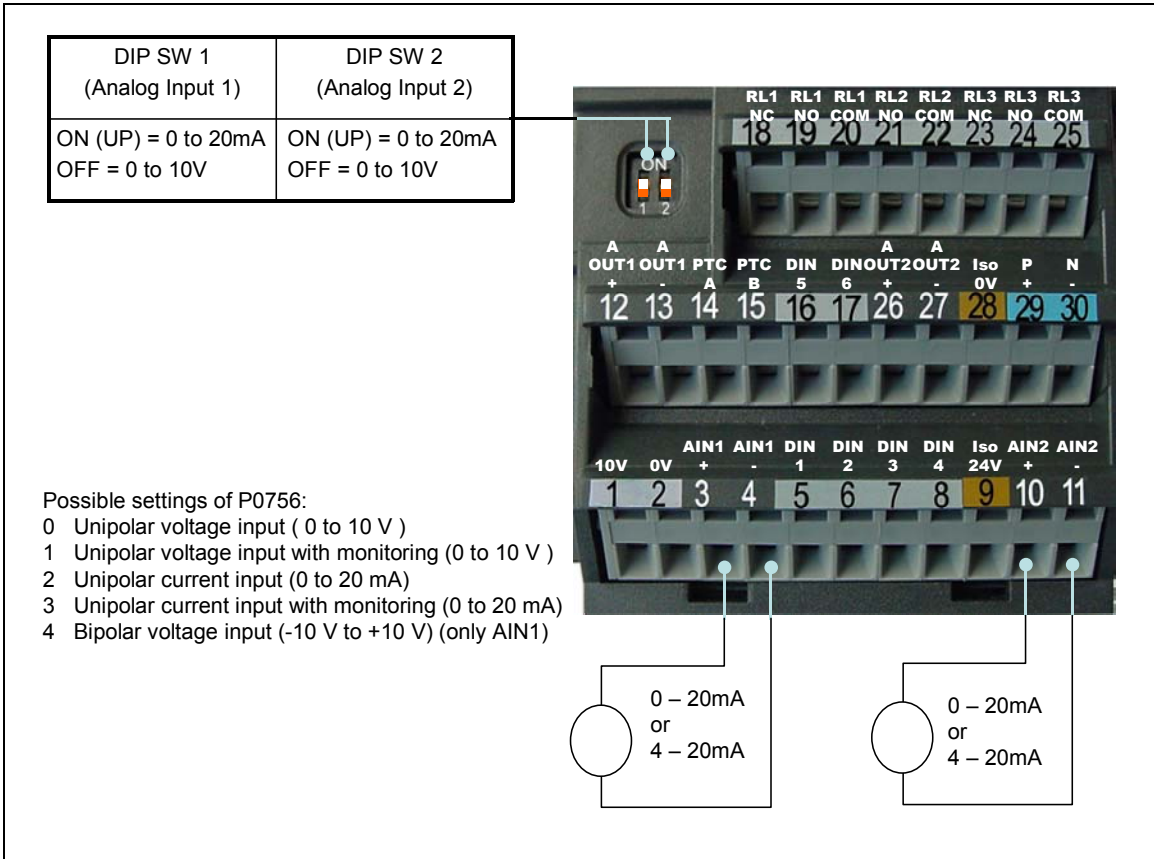

Figure 5-9 DIP Switch And P0756 for Analog Current Input

NOTE

The setting (analog input type) of P0756 must match that of DIP switch DIP1(1,2) on the I/O board. The bipolar voltage input is only possible with analog input 1 (AIN1).

If additional settings are required for your specific application, then please refer to the Operating Instructions and the Parameter List supplied on the CD-ROM with you MM440 drive.

5.8.3 Digital Outputs (Relays) (DOUT)

Parameter range	r0730 – P0748
Features:	
Quantity	3
Cycle time	1 ms
Max. opening / closing time	5 / 10 ms
Voltage / current	30 V DC / 5 A, 250 V AC / 2 A
Function chart number	FP2100 (in parameter list)

Table 5-10 Relay Output Specifications

The MICROMASTER 440 has many status bits and threshold bits which might be useful in the application. You can connect any of the 3 relays to any of these functions.

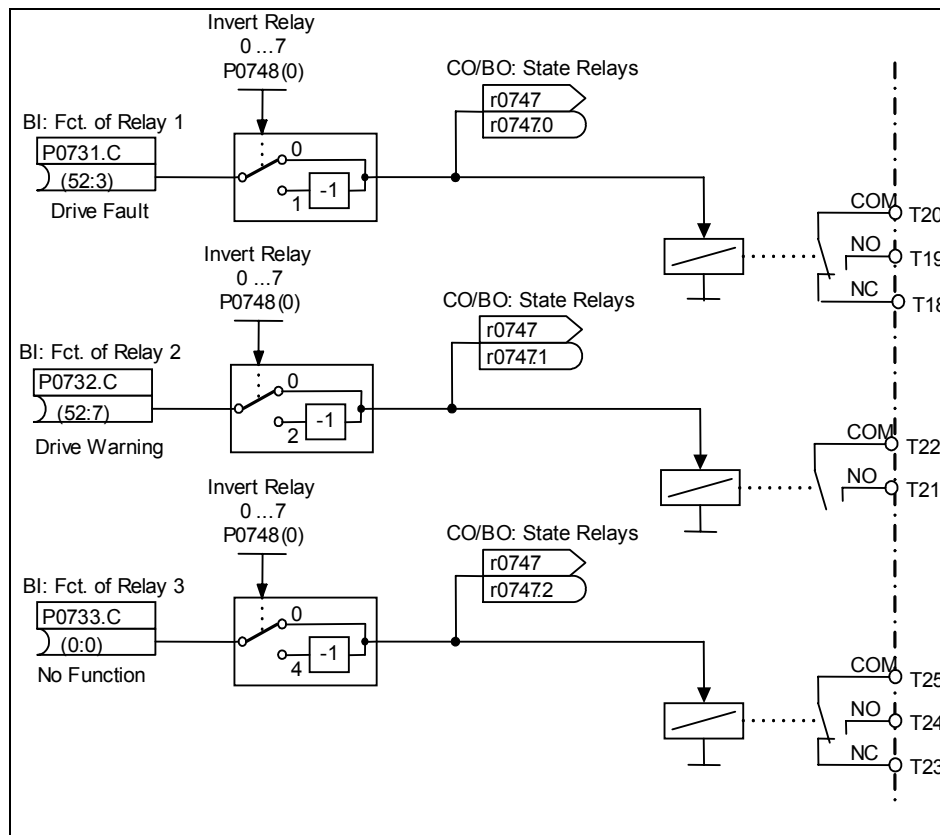

Figure 5-11 Relay Output Functions

Figure 5.11 above shows how a function is connected to the relay (on the left hand side); The signal can be inverted if appropriate for your application using P0748. The output status can be viewed using r0747 where an energized relay is indicated by a bit, and you may connect to the relay terminals on the I/O board.

5.8.4 Commonly Used Relay Functions

Use the settings below in P0731 – P0733 to get the described functionality

Parameter value	Function
52.0	Drive ready
52.1	Drive ready to run
52.2	Drive running
52.3	Drive fault active
52.4	OFF2 active
52.5	OFF3 active
52.6	Switch-on inhibit active
52.7	Drive warning active
52.8	Deviation, setpoint / actual value
52.9	PZD control (Process Data Control)
52.A	Maximum frequency reached
52.B	Warning: Motor current limit
52.C	Motor holding brake (MHB) active
52.D	Motor overload
52.E	Motor running direction right
52.F	Drive overload
53.0	DC brake active
53.1	Act. frequency $f_{act} \geq P2167 (f_{off})$
53.2	Act. frequency $f_{act} > P1080 (f_{min})$
53.3	Act. current $r0027 \geq P2170$
53.6	Act. frequency $f_{act} \geq \text{setpoint}$

Table 5-12 Common Relay Functions

NOTE

Parameter Values above refer to r0052 and r0053 values.

A complete list of all of the connectable parameters may be taken from the parameter list (on the CD that was supplied with the MM440 drive).

5.8.5 Analog outputs (AOUT)

Parameter range	r0770 – P0781
Features:	
Quantity	2
Cycle time	4 ms
Resolution	8 bit
Accuracy	1% referred to 20mA
Function chart number	FP2300 (in Parameter List)

There are many different functions that you can assign to the analog output. These are identified using the “CO” abbreviation in the parameter list. These parameters are typically signals such as setpoints, frequencies or currents. They are converted from their digital form, scaled as you need and then applied in 0-20mA form on the analog output.

For a full list of the “CO” parameters, please consult the parameter list.

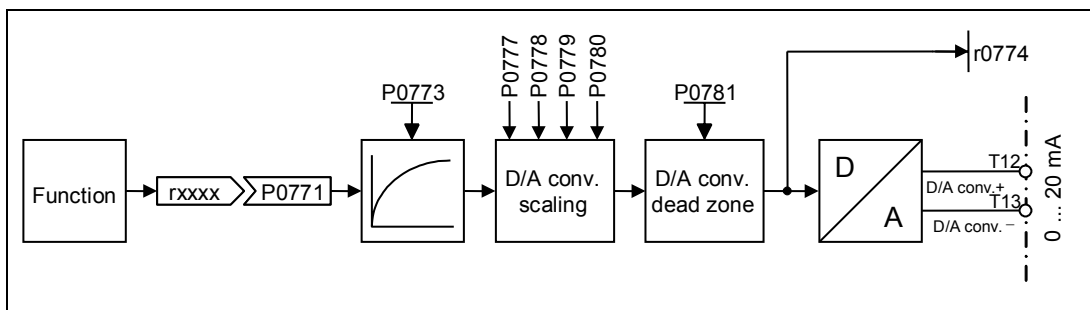

Figure 5-13 – Analog Output Function Diagram

Figure 5.13 above shows how you connect the function that you want to see, to the AOUT (D/A converter). There is a user definable filter (P0773) to smooth the signal, and you have the opportunity to scale the output to suit your application using P0777-P0781. You get the output on the AOUT terminals (0-20mA). If you want voltage instead of current, you can put a 500 Ohm resistor across the output and for a 0-10V output.

5.9 Other Commonly Used Features

5.9.1 Flying Restart

It is possible that your motor may be spinning when you enable the drive, e.g. it is being driven by the load (quite common with fan applications), then it will be necessary to enable the flying restart feature.

Flying restart searches for the speed of the motor and once found, the drive will adjust the output frequency according to the setpoint.

There are a number of options in the flying restart parameter P1200.

Possible Settings:

- 0 Flying start disabled
- 1 Flying start is always active, start in direction of setpoint
- 2 Flying start is active if power on, fault, OFF2, start in direction of setpoint
- 3 Flying start is active if fault, OFF2, start in direction of setpoint
- 4 Flying start is always active, only in direction of setpoint
- 5 Flying start is active if power on, fault, OFF2, only in direction of setpoint
- 6 Flying start is active if fault, OFF2, only in direction of setpoint

For a full explanation of these settings and the more advanced tuning facilities please see the descriptions for P1200, P1202, P1203 in the parameter list (on the supplied CD).

NOTE

Useful for motors with high inertia loads.

Settings 1 to 3 search in both directions.

Settings 4 to 6 search only in direction of setpoint.

NOTE

Flying start must be used in cases where the motor may still be turning (e.g. after a short mains break) or can be driven by the load. Otherwise, overcurrent trips will occur.

5.9.2 Auto-Restart (P1210)

After a power failure (F0003 "Undervoltage"), the "Automatic restart" function (enabled using P1210) automatically powers-up the drive again. Any faults are automatically acknowledged by the drive.

When it comes to power failures (line supply failure), then a differentiation is made between the following conditions:

Line Undervoltage (brownout)

"Line undervoltage" is a situation where the line supply is interrupted and returns before (if installed) the BOP display has gone dark (this is an extremely short line supply interruption where the DC link hasn't completely collapsed).

Line Failure (blackout)

"Line failure" is a situation where the display has gone dark (this represents a longer line supply interruption where the DC link has completely collapsed) before the line supply returns.

The automatic restart function P1210 is shown in the following diagram (refer to Table 5.1) as a function of external states / events.

P1210	ON always active				ON in the no-voltage state
	Fault F0003 for Blackout	Brownout	All other faults for Blackout	Brownout	All faults + F0003
0	–	–	–	–	–
1	Fault acknowl.	–	–	–	Fault acknowl.
2	Fault acknowl. + restart	–	–	–	Fault acknowl. + restart
3	Fault acknowl. + restart	Fault acknowl. + restart	Fault acknowl. + restart	Fault acknowl. + restart	–
4	Fault acknowl. + restart	Fault acknowl. + restart	–	–	–
5	Fault acknowl. + restart	–	–	Fault acknowl. + restart	Fault acknowl. + restart
6	Fault acknowl. + restart	Fault acknowl. + restart	Fault acknowl. + restart	Fault acknowl. + restart	Fault acknowl. + restart

Table 5-1 Automatic Restarts

The number of start attempts is specified using parameter P1211. The number is internally decreased after each unsuccessful attempt. After all attempts have been made (as specified in parameter P1211), automatic restart is cancelled with message F0035. After a successful start attempt, the counter is again reset to the initial value.

NOTE

- The "Flying restart" function (refer to Section 5.9.1) must be additionally activated if, for an automatic restart, the drive inverter is to be connected to a motor which may already be spinning.



DANGER

- For longer line supply failures (blackouts) and when the automatic restart function is activated, over a longer period of time it may be assumed that MICROMASTER is powered-down. However, when the line supply returns, motors can automatically start to run again without any operator intervention.
 - If the operating range of the motors is entered in this status, this can result in death, severe injury or material damage.
-

5.9.3 PID Control

Refer to Operating Instructions for further details or to Technical Support Website (see page 63)

5.9.4 Sensorless Vector Control (SLVC) / Vector Control (VC)

Refer to Operating Instructions for further details on using Vector Control or Sensorless Vector Control or to Technical Support Website (see page 67 for contact details)

6 Troubleshooting



WARNING

- Repairs on equipment may only be carried out by **Siemens Service & Repair Centers** – See page 67 for contact details.
- Any defective parts or components must be replaced using parts contained in the relevant spare parts list.
- Disconnect the power supply before opening the equipment for access

6.1 Troubleshooting Using the Status Display Panel (SDP)

It is possible to do a limited amount of troubleshooting using the SDP, however for more detailed troubleshooting you will need a BOP or AOP or Serial link to give you parameter access.

The table below explains the meaning of the various states of the LEDs on the SDP.

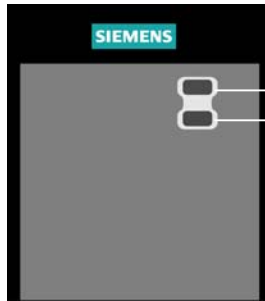

- LEDs for indicating the drive state
- Off
 - ☀ On
 - ⦿ approx. 0,3 s, flashing
 - ⦿ approx. 1 s, blinking

●	Mains not present
☀	Ready to run
●	Inverter fault - other than the ones listed below
☀	Inverter running
●	Fault overcurrent
⦿	Fault overvoltage
⦿	Fault motor overtemperature

☀	Fault inverter temperature
⦿	Warning current limit - both LEDs blinking same time
⦿	Other warnings - both LEDs blinking alternatively
⦿	Undervoltage trip / undervoltage warning
⦿	Drive is not in ready state
⦿	ROM failure - Both LEDs flashing same time
⦿	RAM failure - Both LEDs flashing alternatively

6.1.1 Checking Wiring to Digital Inputs

When you look at r0722 you will get a display that looks something like the one shown in figures below. r0722 is a bit parameter. Each bit reflects a different digital input or analog input. You should see the bits toggling on and off as you change the state of the inputs. If you do not see any change then you should check your wiring.

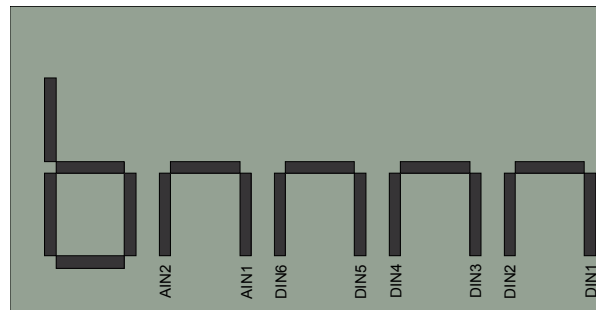

Figure 6-1 r0722 Binary Input Values

For example if DIN1 and DIN4 are high then your display will look like this:



Figure 6-2 r0722 Binary Input Values Example

6.1.2 Checking Wiring to Analog Inputs

You can also use r0722 for some basic testing of the analog inputs. Bits 6 and 7 in r0722 show AIN1 and AIN2 respectively. If the AIN signal is low (<2V) the bit will be OFF, with your AIN input set high (>4V) the bit will be ON. This parameter should be used just to check that your connection is OK



Figure 6-3 r0722 Display When Both AINs High.

There are some other parameters that can also be used to troubleshoot your analog signals.

6.2 Faults and Alarms (Warnings)

Listed below are the Faults & Warnings that are most common. Other Fault and Alarm codes exist. If you get one not included below – please refer to the Parameter List (on the CD that came with the MM440 drive). It is also possible that further information exists in the Parameter list for the faults listed below.

Fault / Warning	Description	Cause / Remedy
F0001	Overcurrent	<ul style="list-style-type: none"> • Motor cables are too long – fit output choke, or move drive closer to motor. • Short circuit in motor leads – locate and correct short circuit • Earth fault present – Check and correct for earth faults • Stator resistance value incorrect – perform motor ID on cold motor (P1910=1) • Motor is obstructed – remove obstruction • Ramp up time is too short – lengthen ramp up time • Boost level is too high – reduce boost level (P1310-P1312 for V/f, P1610, P1611 for Vector control) • Motor parameters are incorrect – re-perform Quick Commissioning and enter corrected motor data) • Motor too large for drive – get larger drive.
F0002	Overvoltage	<ul style="list-style-type: none"> • Line Voltage too high – check and correct line voltage to suit drive – or get a drive to suit line voltage. Prolonged exposure to excessive line voltage will damage the inverter. • Too much regenerative energy – use VDC Max controller (P1240) to lengthen ramp down times, manually increase ramp down times or fit a braking resistor. The ramp down time has to match the inertia of the load • Voltage spikes on line voltage – add a line reactor.
F0003	Undervoltage	<ul style="list-style-type: none"> • Line supply too low – check and correct line voltage to suit drive – or get a drive to suit line voltage. • Line supply interruption – a power outage when the drive is running – ensure stable supply. • Shock load outside of specification (1ph drives only) – ensure that load is suitable for the drive.
F0004	Inverter Overtemperature	<ul style="list-style-type: none"> • Ventilation is inadequate – improve ventilation – See section 1.2 for further details • Ambient temperature is too high – ensure that ambient temperature is within the limits defined for the drive. • Fan is obstructed – remove obstruction • Fan is defective – replace fan
F0005	Inverter I2T (overload)	<ul style="list-style-type: none"> • Drive is overloaded – load needs to be reduced – or a larger drive should be used. • Duty cycle too demanding – load needs to be reduced or larger drive should be used. • Motor too large for drive – load needs to be reduced or larger drive should be used.

Fault / Warning	Description	Cause / Remedy
F0011	Motor Overtemperature (Overloaded)	<ul style="list-style-type: none"> • Check and correct duty cycle • Check if motor name plate information has been entered correctly – if not, then re-perform quick commissioning using correct data. Most common incorrect parameter is P0309 (motor efficiency). If this value is too low, the calculated temperature will be incorrect. • Perform Motor ID P1910=1 on a cold motor • Check that motor weight is correct (P0344 – correct if necessary) • If temperature sensors are fitted, check r0035 to see if they are realistic, if not check that you have the correct type of sensor.
F0022	Power Stack Fault	<ul style="list-style-type: none"> • DC Link over current – check the following; Chopper short circuit, braking resistor resistance too low, ground fault on output, IGBT failure (disconnect motor leads and try to run – if fault still comes then IGBT failure has occurred) • I/O board not properly seated – remove and re-clip into position. • Poor Grounding on motor leads – check and improve if necessary.
F0041	Motor Identification Failure	<ul style="list-style-type: none"> • Check that motor is connected. • Check that ALL motor data is correct for wiring designation (Wye/Delta) – Re-perform quick commissioning to correct this if necessary.
F0080	Analog Input Signal Lost	<ul style="list-style-type: none"> • Signal wire broken – check and correct • Signal out of range – check and correct
F0085	External Trip Active	<ul style="list-style-type: none"> • External fault signal activated – reset active external fault
A0501	Current Limit Warning	<ul style="list-style-type: none"> • Cable length limits must not be exceeded • Motor cable and motor must have no short-circuits or earth faults • Motor parameters must match the motor in use • Value of stator resistance (P0350) must be correct • Motor must not be obstructed or overloaded • Increase the ramp-up-time. • Reduce the boost level (V/f control: P1311 & P1312, Vector control: P1610 & P1611) • Motor power (P0307) must correspond to inverter power (r0206)
A0502	Upper Voltage Limit Warning	<ul style="list-style-type: none"> • Supply voltage (P0210) must lie within limits indicated on drive name plate • DC-link voltage controller must be enabled (P1240) and parameterized properly • Ramp-down time (P1121) must match inertia of load • Required braking power must lie within specified limits
A0503	Lower Voltage Limit Warning	<ul style="list-style-type: none"> • Supply voltage (P0210) must lie within limits indicated on rating plate • Supply must not be susceptible to temporary failures or voltage reductions • Enable kinetic buffering (P1240 = 2)
A0504	Inverter Over temperature Warning	<ul style="list-style-type: none"> • Load conditions and duty cycle must be appropriate • Fan must turn when inverter is running • Pulse frequency (P1800) must be set to default value • Ambient temperature could be higher than specified for the inverter
A0505	Inverter Overload	<ul style="list-style-type: none"> • Load duty cycle must lie within specified limits

Fault / Warning	Description	Cause / Remedy
	Warning	<ul style="list-style-type: none"> Motor power (P0307) must match inverter power (r0206)
A0511	Motor Over temperature Warning	<ul style="list-style-type: none"> Load duty cycle must be correct Check if name plate data are correct (if not perform quick commissioning) Accurate equivalent circuit data can be found by performing motor identification (P1910=1) Check if motor weight (P0344) is reasonable. Change if necessary Check if temperature shown in r0035 is reasonable
A0541	Motor Identification Active	<ul style="list-style-type: none"> Motor data identification (P1910) selected or running
A0910	VDC Max Controller Deactivated Warning	<ul style="list-style-type: none"> Occurs if main supply voltage (compared to P0210) is permanently too high Occurs if motor is driven by an active load, causing motor to go into regenerative mode Occurs at very high load inertias, when ramping down
A0911	VDC Max Controller Active Warning	<ul style="list-style-type: none"> Vdc max controller is active; so ramp-down times will be increased automatically to keep DC-link voltage (r0026) within limits (P2172).
A0920	Analog Input Parameters Incorrect Warning	<ul style="list-style-type: none"> AIN parameters incorrect – check that they are not set to identical values. Check that parameters are logical for AIN type.
A0921	Analog Output Parameters Incorrect Warning	<ul style="list-style-type: none"> AOUT parameters are incorrect. Check that settings are not identical to each other.
A0922	No Load Applied to Inverter Warning	<ul style="list-style-type: none"> No Load is applied to the inverter – (Motor not connected) - Check wiring to motor.
A0923	Jog Left and Jog Right Applied Warning	<ul style="list-style-type: none"> Both JOG right and JOG left (P1055/P1056) have been requested. This freezes the RFG output frequency at its current value.

6.3 Where to Get Additional Technical Information

Technical Support and Field Services

Tel: 1-800-333-7421 (Inside USA, Toll Free) / 1-423-262-2522 (Outside USA)

Email: simatic.support@sea.siemens.com

Spare Parts and Repair

Tel 1-800-241-4453 (Inside USA, Toll Free) / 1-770-740-3505 (Outside USA)

Email: isd.callcenter@sea.siemens.com

Internet Home Address

Customers can access FAQs, Technical Documentation, Windows™ Software e.g. DriveMonitor / Starter Updates and other general information at: www.siemens.com/micromaster

Sales Support

Centers of Excellence

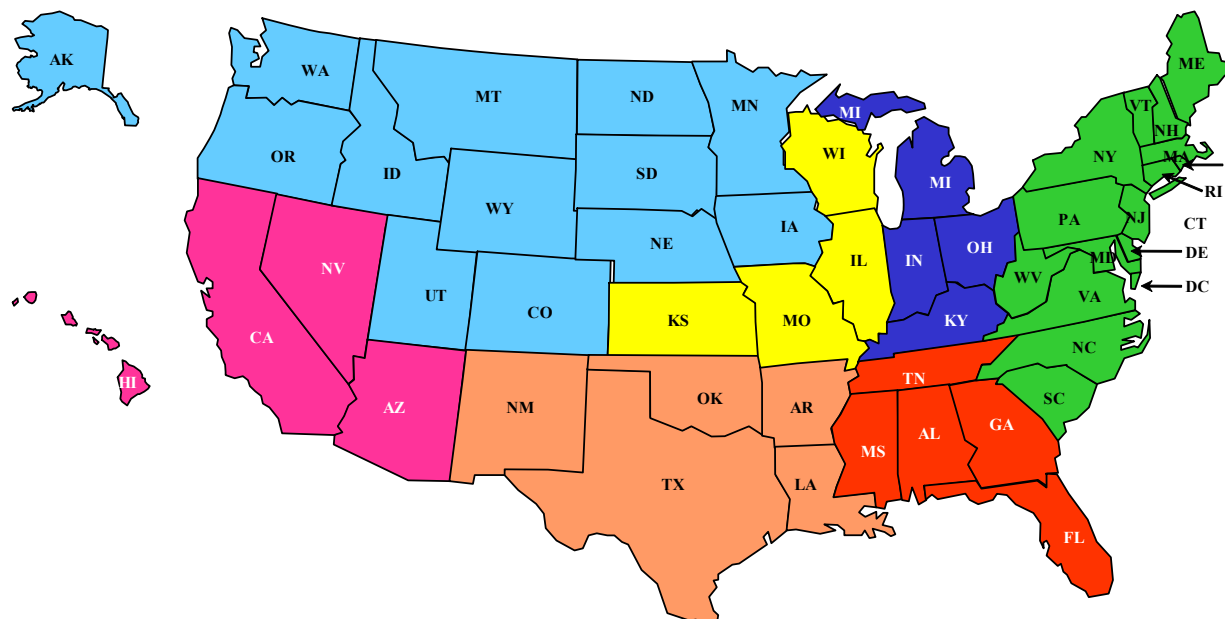

Cypress 877-548-0920 (P) 714-527-7406 (F)	Chicago 800-333-7732 (P) 847-310-4298 (F)	Houston 800-879-6891 (P) 713-690-1210 (F)	
Denver 800-955-7072 (P) 303-694-3622 (F)	Atlanta 800-207-7186 (P) 770-453-3454 (F)	Philadelphia 800-388-8067 (P) 215-283-9902 (F)	Indianapolis 800-338-2144 (P) 317-616-4801 (F)

Marketing / Documentation Support

Should any questions or problems arise regarding this manual, please contact GPD-marketing@sea.siemens.com - please quote the Issue Number from the document and the page number/section that you have a question about.

Alternatively you can fax us on 1-678-297-7259

Siemens Energy & Automation, Inc.

3333 Old Milton Parkway
Alpharetta, GA 30005

1-800-964-4114

seainfo@sea.siemens.com

www.siemens.com/micromaster

© 2003 Siemens Energy & Automation, Inc.

The Siemens logo and MICROMASTER are registered trademarks of Siemens AG. Product names mentioned may be trademarks or registered trademarks of their respective companies. Specifications are subject to change without notice.

Order Number: 6SE6400-5GA00-0BP0

Printed in USA SS5M0803