



**Allen-Bradley**

# **PowerFlex<sub>4</sub>**

## **Adjustable Frequency AC Drive**

**FRN 2.xx**

**User Manual**

[www.abpowerflex.com](http://www.abpowerflex.com)

**Rockwell  
Automation**

## Important User Information

Solid state equipment has operational characteristics differing from those of electromechanical equipment. “*Safety Guidelines for the Application, Installation and Maintenance of Solid State Controls*” (Publication SGI-1.1 available from your local Allen-Bradley Sales Office or online at <http://www.ab.com/manuals/gi>) describes some important differences between solid state equipment and hard-wired electromechanical devices. Because of this difference, and also because of the wide variety of uses for solid state equipment, all persons responsible for applying this equipment must satisfy themselves that each intended application of this equipment is acceptable.

In no event will the Allen-Bradley Company be responsible or liable for indirect or consequential damages resulting from the use or application of this equipment.

The examples and diagrams in this manual are included solely for illustrative purposes. Because of the many variables and requirements associated with any particular installation, the Allen-Bradley Company cannot assume responsibility or liability for actual use based on the examples and diagrams.

No patent liability is assumed by Allen-Bradley Company with respect to use of information, circuits, equipment, or software described in this manual.

Reproduction of the contents of this manual, in whole or in part, without written permission of the Allen-Bradley Company is prohibited.

Throughout this manual we use notes to make you aware of safety considerations.



**ATTENTION:** Identifies information about practices or circumstances that can lead to personal injury or death, property damage, or economic loss.

---

Attentions help you:

- identify a hazard
- avoid the hazard
- recognize the consequences

**Important:** Identifies information that is especially important for successful application and understanding of the product.

---



**Shock Hazard** labels may be located on or inside the drive to alert people that dangerous voltage may be present.

---



**Burn Hazard** labels may be located on or inside the drive to alert people that surfaces may be at dangerous temperatures.

---

DriveExplorer, DriveTools32, and SCANport are trademarks of Rockwell Automation.

PLC is a registered trademark of Rockwell Automation.

ControlNet is a trademark of ControlNet International, Ltd.

DeviceNet is a trademark of the Open DeviceNet Vendor Association.

## Summary of Changes

---

The information below summarizes the changes to the PowerFlex 4 User Manual since the last release.

<b>Description of New or Updated Information</b>	<b>See Page(s)</b>
Minimum mounting clearances between drive reduced to 25 mm (1.0 in.).	1-2
Expanded information on branch circuit protective devices.	1-7
New information on I/O wiring including additional wiring examples.	1-13 – 1-16
Expanded specifications information.	A-2
Section on RS485 (DSI) Protocol added.	C-1 – C-5
The following parameter descriptions or values have changed:	
P037 [Stop Mode] – Description changed	3-10
A084 [Start Boost] – New default value for 5 HP drives	3-19
A107 [Comm Format] – Description changed	3-24
The following parameters have been added:	
d020 [0-10V Analog Input]	3-7
d021 [4-20mA Analog Input]	3-7
A110 [0-10V Analog Input Low]	3-24
A111 [0-10V Analog Input High]	3-25
A112 [4-20mA Analog Input Low]	3-25
A113 [4-20mA Analog Input High]	3-25
A114 [Slip Compensation]	3-25



# Table of Contents

---

<b>Preface</b>	<b>Overview</b>	
		Who Should Use this Manual? . . . . . P-1
		Reference Materials. . . . . P-1
		Manual Conventions . . . . . P-2
		Drive Frame Sizes . . . . . P-2
		General Precautions. . . . . P-3
		Catalog Number Explanation . . . . . P-4
<b>Chapter 1</b>	<b>Installation/Wiring</b>	
		Opening the Cover. . . . . 1-1
		Mounting Considerations . . . . . 1-2
		AC Supply Source Considerations . . . . . 1-3
		General Grounding Requirements. . . . . 1-4
		Fuses and Circuit Breakers . . . . . 1-6
		Power Wiring. . . . . 1-8
		I/O Wiring Recommendations. . . . . 1-11
		Start and Speed Reference Control . . . . . 1-17
		EMC Instructions . . . . . 1-19
<b>Chapter 2</b>	<b>Start Up</b>	
		Prepare For Drive Start-Up . . . . . 2-1
		Integral Keypad . . . . . 2-3
		Viewing and Editing Parameters . . . . . 2-4
<b>Chapter 3</b>	<b>Programming and Parameters</b>	
		About Parameters . . . . . 3-1
		Parameter Organization. . . . . 3-2
		Display Group . . . . . 3-3
		Basic Program Group . . . . . 3-8
		Advanced Program Group. . . . . 3-13
		Parameter Cross Reference – by Name. . . 3-26
<b>Chapter 4</b>	<b>Troubleshooting</b>	
		Drive Status . . . . . 4-1
		Faults . . . . . 4-1
		Fault Descriptions . . . . . 4-3
		Common Symptoms and Corrective Actions. . . . . 4-5
<b>Appendix A</b>	<b>Supplemental Drive Information</b>	
		Drive, Fuse & Circuit Breaker Ratings . . . A-1
		Specifications . . . . . A-2
<b>Appendix B</b>	<b>Accessories and Dimensions</b>	
		Product Selection. . . . . B-1
		Product Dimensions . . . . . B-5
<b>Appendix C</b>	<b>RS485 (DSI) Protocol</b>	
<b>Index</b>		



## Overview

The purpose of this manual is to provide you with the basic information needed to install, start-up and troubleshoot the PowerFlex 4 Adjustable Frequency AC Drive.

For information on...	See page...
<a href="#">Who Should Use this Manual?</a>	<a href="#">P-1</a>
<a href="#">Reference Materials</a>	<a href="#">P-1</a>
<a href="#">Manual Conventions</a>	<a href="#">P-2</a>
<a href="#">Drive Frame Sizes</a>	<a href="#">P-2</a>
<a href="#">General Precautions</a>	<a href="#">P-3</a>
<a href="#">Catalog Number Explanation</a>	<a href="#">P-4</a>

### Who Should Use this Manual?

This manual is intended for qualified personnel. You must be able to program and operate Adjustable Frequency AC Drive devices. In addition, you must have an understanding of the parameter settings and functions.

### Reference Materials

The following manuals are recommended for general drive information:

Title	Publication	Available Online at ...
Industrial Automation Wiring and Grounding Guidelines	1770-4.1	<a href="http://www.ab.com/manuals/gi">www.ab.com/manuals/gi</a>
Preventive Maintenance of Industrial Control and Drive System Equipment	DRIVES-SB001A-EN-E	<a href="http://www.ab.com/manuals/dr">www.ab.com/manuals/dr</a>
Safety Guidelines for the Application, Installation and Maintenance of Solid State Control	SGI-1.1	<a href="http://www.ab.com/manuals/gi">www.ab.com/manuals/gi</a>
A Global Reference Guide for Reading Schematic Diagrams	0100-2.10	<a href="http://www.ab.com/manuals/ms">www.ab.com/manuals/ms</a>
Guarding Against Electrostatic Damage	8000-4.5.2	<a href="http://www.ab.com/manuals/dr">www.ab.com/manuals/dr</a>

## Manual Conventions

- In this manual we refer to the PowerFlex 4 Adjustable Frequency AC Drive as; drive, PowerFlex 4 or PowerFlex 4 Drive.
- Parameter numbers and names are shown in this format:

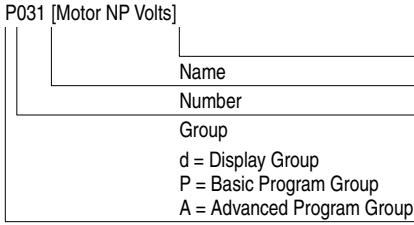

- The following words are used throughout the manual to describe an action:

Word	Meaning
Can	Possible, able to do something
Cannot	Not possible, not able to do something
May	Permitted, allowed
Shall	Required and necessary
Should	Recommended
Should Not	Not Recommended

## Drive Frame Sizes

Similar PowerFlex 4 drive sizes are grouped into frame sizes to simplify spare parts ordering, dimensioning, etc. A cross reference of drive catalog numbers and their respective frame sizes is provided in [Appendix B](#).

---

## General Precautions

---



**ATTENTION:** The drive contains high voltage capacitors which take time to discharge after removal of mains supply. Before working on drive, ensure isolation of mains supply from line inputs [R, S, T (L1, L2, L3)]. Wait three minutes for capacitors to discharge to safe voltage levels. Failure to do so may result in personal injury or death.

Darkened display LEDs is not an indication that capacitors have discharged to safe voltage levels.



**ATTENTION:** Only qualified personnel familiar with adjustable frequency AC drives and associated machinery should plan or implement the installation, start-up and subsequent maintenance of the system. Failure to comply may result in personal injury and/or equipment damage.



**ATTENTION:** This drive contains ESD (Electrostatic Discharge) sensitive parts and assemblies. Static control precautions are required when installing, testing, servicing or repairing this assembly. Component damage may result if ESD control procedures are not followed. If you are not familiar with static control procedures, reference A-B publication 8000-4.5.2, “Guarding Against Electrostatic Damage” or any other applicable ESD protection handbook.



**ATTENTION:** An incorrectly applied or installed drive can result in component damage or a reduction in product life. Wiring or application errors, such as, undersizing the motor, incorrect or inadequate AC supply, or excessive ambient temperatures may result in malfunction of the system.

---

## Catalog Number Explanation

<b>22A</b>	<b>-</b>	<b>A</b>	<b>1P5</b>	<b>N</b>	<b>1</b>	<b>1</b>	<b>4</b>
Drive	Dash	Voltage Rating	Rating	Enclosure	HIM	Emission Class	Comm Slot

**Code**  
22A PowerFlex 4

**Code Version**  
4 RS485

**Code Rating**  
0 No Filter  
1 Integral EMI Filter

Code	Voltage	Ph.
V	120V AC	1
A	240V AC	1
B	240V AC	3
D	480V AC	3

**Code Interface Module**  
1 Fixed Keypad

**Code Enclosure**  
N Panel Mount - IP 20 (NEMA Type Open)

Output Current @ 380-480V Input

Code	Amps	kW (HP)
1P4	1.4	0.37 (0.5)
2P3	2.3	0.75 (1.0)
4P0	4.0	1.5 (2.0)
6P0	6.0	2.2 (3.0)
8P7	8.7	3.7 (5.0)

Output Current @ 100-120 Input or 200-240V Input

Code	Amps	kW (HP)
1P5	1.5	0.2 (0.25)
2P3	2.3	0.37 (0.5)
4P5	4.5	0.75 (1.0)
8P0	8.0	1.5 (2.0)
012	12	2.2 (3.0)
017	17.5	3.7 (5.0)

## Installation/Wiring

This chapter provides information on mounting and wiring the PowerFlex 4 Drive.

For information on...	See page	For information on...	See page
<a href="#">Opening the Cover</a>	1-1	<a href="#">Fuses and Circuit Breakers</a>	1-6
<a href="#">Mounting Considerations</a>	1-2	<a href="#">Power Wiring</a>	1-8
<a href="#">AC Supply Source Considerations</a>	1-3	<a href="#">I/O Wiring Recommendations</a>	1-11
<a href="#">General Grounding Requirements</a>	1-4	<a href="#">EMC Instructions</a>	1-19

Most start-up difficulties are the result of incorrect wiring. Every precaution must be taken to assure that the wiring is done as instructed. All items must be read and understood before the actual installation begins.



**ATTENTION:** The following information is merely a guide for proper installation. The Allen-Bradley Company cannot assume responsibility for the compliance or the noncompliance to any code, national, local or otherwise for the proper installation of this drive or associated equipment. A hazard of personal injury and/or equipment damage exists if codes are ignored during installation.

### Opening the Cover

1. Press and hold in the tabs on each side of the cover.
2. Pull the cover out and up to release.

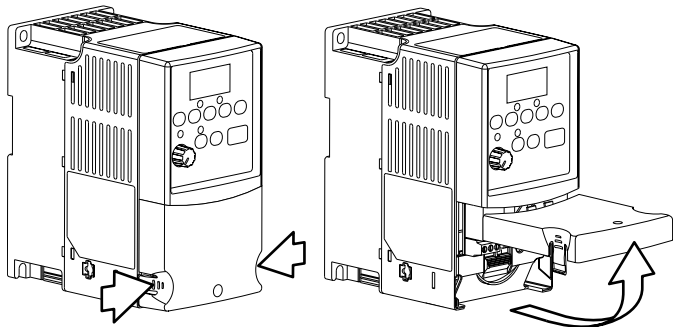

## Mounting Considerations

- Mount the drive upright on a flat, vertical and level surface.
  - Install on 35 mm DIN Rail.
  - or
  - Install with screws.

**Table 1.A Screw Mounting Recommendations**

Minimum Panel Thickness	Screw Size	Mounting Torque
1.9 mm (0.0747 in.)	m4 x 0.7 (#8-32)	1.56-1.96 Nm (14-17 lb.-in.)

- Protect the cooling fan by avoiding dust or metallic particles.
- Do not expose to a corrosive atmosphere.
- Protect from moisture and direct sunlight.

## Minimum Mounting Clearances

Refer to [Appendix B](#) for mounting dimensions.

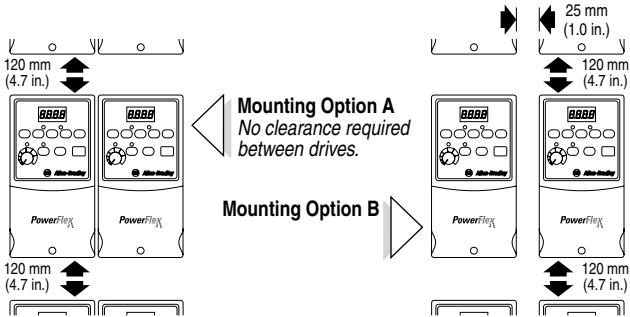

## Ambient Operating Temperatures

**Table 1.B Enclosure and Clearance Requirements**

Ambient Temperature		Enclosure Rating	Minimum Mounting Clearances
Minimum	Maximum		
-10°C (14°F)	40°C (104°F)	IP 20/Open Type	Use Mounting Option A
		IP 30/NEMA 1/UL Type 1 <sup>(1)</sup>	Use Mounting Option B
	50°C (122°F)	IP 20/Open Type	Use Mounting Option B

<sup>(1)</sup> Rating requires installation of the PowerFlex 4 IP 30/NEMA 1/UL Type 1 option kit.

## Debris Protection

A plastic top panel is included with the drive. Install the panel to prevent debris from falling through the vents of the drive housing during installation. Remove the panel for IP 20/Open Type applications.

## Storage

- Store within an ambient temperature range of -40° to +85°C.
- Store within a relative humidity range of 0% to 95%, non-condensing.
- Do not expose to a corrosive atmosphere.

## AC Supply Source Considerations

### Ungrounded Distribution Systems



**ATTENTION:** PowerFlex 4 drives contain protective MOVs that are referenced to ground. These devices should be disconnected if the drive is installed on an ungrounded distribution system.

#### Disconnecting MOVs

To prevent drive damage, the MOVs connected to ground shall be disconnected if the drive is installed on an ungrounded distribution system where the line-to-ground voltages on any phase could exceed 125% of the nominal line-to-line voltage. To disconnect these devices, remove the jumper shown in the Figures 1.1 and 1.2.

1. Turn the screw counterclockwise to loosen.
2. Pull the jumper completely out of the drive chassis.
3. Tighten the screw to keep it in place.

**Figure 1.1 Jumper Location (A Frame Shown)**

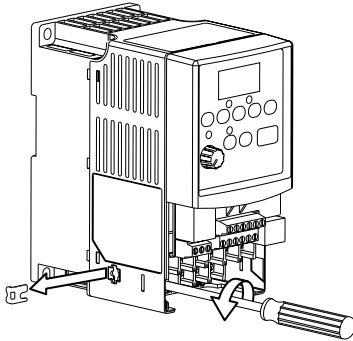

**Important:**  
Tighten screw after  
jumper removal.

**Figure 1.2 Phase to Ground MOV Removal**

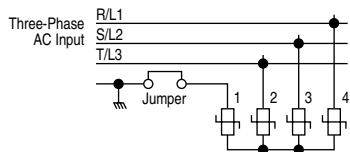

### Input Power Conditioning

The drive is suitable for direct connection to input power within the rated voltage of the drive (see [Appendix A](#)). Listed in [Table 1.C](#) are certain input power conditions which may cause component damage or reduction in product life. If any of the conditions exist, as described in [Table 1.C](#), install one of the devices listed under the heading *Corrective Action* on the line side of the drive.

**Important:** Only one device per branch circuit is required. It should be mounted closest to the branch and sized to handle the total current of the branch circuit.

**Table 1.C Input Power Conditions**

Input Power Condition	Corrective Action
Low Line Impedance (less than 1% line reactance)	<ul style="list-style-type: none"> <li>• Install Line Reactor<sup>(1)</sup></li> <li>• or Isolation Transformer</li> </ul>
Greater than 120 kVA supply transformer	
Line has power factor correction capacitors	
Line has frequent power interruptions	
Line has intermittent noise spikes in excess of 6000V (lightning)	
Phase to ground voltage exceeds 125% of normal line to line voltage	<ul style="list-style-type: none"> <li>• Remove MOV jumper to ground.</li> <li>• or Install Isolation Transformer with grounded secondary if necessary.</li> </ul>
Ungrounded distribution system	

<sup>(1)</sup> Refer to [Appendix B](#) for accessory ordering information.

### General Grounding Requirements

The drive Safety Ground -  $\oplus$  (PE) must be connected to system ground. Ground impedance must conform to the requirements of national and local industrial safety regulations and/or electrical codes. The integrity of all ground connections should be periodically checked.

**Figure 1.3 Typical Grounding**

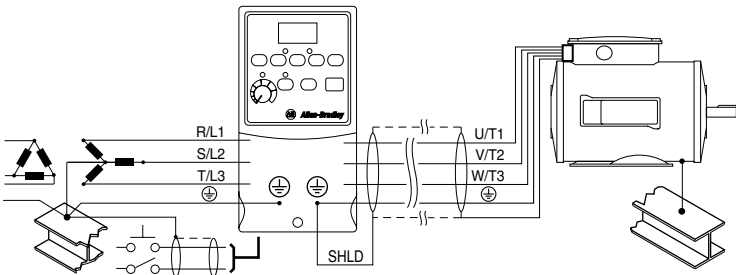

## Ground Fault Monitoring

If a system ground fault monitor (RCD) is to be used, only Type B (adjustable) devices should be used to avoid nuisance tripping.

## Safety Ground - $\ominus$ (PE)

This is the safety ground for the drive that is required by code. One of these points must be connected to adjacent building steel (girder, joist), a floor ground rod or bus bar. Grounding points must comply with national and local industrial safety regulations and/or electrical codes.

## Motor Ground

The motor ground must be connected to one of the ground terminals on the drive.

## Shield Termination - SHLD

Either of the safety ground terminals located on the power terminal block provides a grounding point for the motor cable shield. The **motor cable** shield connected to one of these terminals (drive end) should also be connected to the motor frame (motor end). Use a shield terminating or EMI clamp to connect the shield to the safety ground terminal. The conduit box option may be used with a cable clamp for a grounding point for the cable shield.

When shielded cable is used for **control and signal wiring**, the shield should be grounded at the source end only, not at the drive end.

## RFI Filter Grounding

Using single phase drives with integral filter, or an external filter with any drive rating, may result in relatively high ground leakage currents. Therefore, the **filter must only be used in installations with grounded AC supply systems and be permanently installed and solidly grounded** (bonded) to the building power distribution ground. Ensure that the incoming supply neutral is solidly connected (bonded) to the same building power distribution ground. Grounding must not rely on flexible cables and should not include any form of plug or socket that would permit inadvertent disconnection. Some local codes may require redundant ground connections. The integrity of all connections should be periodically checked.

## Fuses and Circuit Breakers

The PowerFlex 4 does not provide branch short circuit protection. This product should be installed with either input fuses or an input circuit breaker. National and local industrial safety regulations and/or electrical codes may determine additional requirements for these installations.

---



**ATTENTION:** To guard against personal injury and/or equipment damage caused by improper fusing or circuit breaker selection, use only the recommended line fuses/circuit breakers specified in this section.

---

### Fusing

The PowerFlex 4 has been UL tested and approved for use with input fuses. The ratings in the table that follows are the minimum recommended values for use with each drive rating. The devices listed in this table are provided to serve as a guide. Other devices which meet the requirements of UL508C and UL489 with similar trip characteristics may be used in order to meet local or national electrical codes.

### Bulletin 140 Manual Motor Starters/UL489 Circuit Breakers

When using Bulletin 140 manual motor starters or UL489 rated circuit breakers, the guidelines listed below must be followed in order to meet the NEC requirements for branch circuit protection.

- Bulletin 140 manual motor starters can be used in single and group motor applications.
- In single motor applications, a fuse or UL489 rated circuit breaker is required ahead of the Bulletin 140 manual motor starter.
- In group motor installations, the Bulletin 140 can be used for protection of an individual motor within the group and “one set” of fuses or a UL489 rated circuit breaker serves as the Branch Circuit Protective Device for the entire “Group Installation”.
- If the installation is not required to meet NEC requirements, Bulletin 140M manual motor starters can be used in single and group motor applications without additional short circuit protection. Refer to the technical support literature for the 140M for more details.

**Table 1.D Minimum Recommended Branch Circuit Protective Devices**

<b>Voltage Rating</b>	<b>Drive Rating kW (HP)</b>	<b>Fuse Rating<sup>(1)</sup> Amps</b>	<b>140M Motor Protectors Catalog No.</b>	<b>Recommended MCS Contactors Catalog No.</b>
120V AC – 1-Phase	0.2 (0.25)	10	140M-C2E-C10	100-C09
	0.37 (0.5)	15	140M-C2E-C16	100-C12
	0.75 (1.0)	30	140M-D8E-C20	100-C23
240V AC – 1-Phase	0.2 (0.25)	10	140M-C2E-B63	100-C09
	0.37 (0.5)	10	140M-C2E-B63	100-C09
	0.75 (1.0)	15	140M-C2E-C16	100-C12
	1.5 (2.0)	30	140M-D8E-C20	100-C23
240V AC – 3-Phase	0.2 (0.25)	3	140M-C2E-B25	100-C09
	0.37 (0.5)	6	140M-C2E-B40	100-C09
	0.75 (1.0)	10	140M-C2E-C10	100-C09
	1.5 (2.0)	15	140M-C2E-C16	100-C12
	2.2 (3.0)	25	140M-C2E-C16	100-C16
	3.7 (5.0)	35	140M-F8E-C25	100-C23
480V AC – 3-Phase	0.37 (0.5)	3	140M-C2E-B25	100-C09
	0.75 (1.0)	6	140M-C2E-B40	100-C09
	1.5 (2.0)	10	140M-C2E-B63	100-C09
	2.2 (3.0)	15	140M-C2E-C10	100-C09
	3.7 (5.0)	15	140M-C2E-C16	100-C16

<sup>(1)</sup> Recommended Fuse Type: UL Class J, CC, T or Type BS88; 600V (550V) or equivalent.

## Power Wiring



**ATTENTION:** National Codes and standards (NEC, VDE, BSI, etc.) and local codes outline provisions for safely installing electrical equipment. Installation must comply with specifications regarding wire types, conductor sizes, branch circuit protection and disconnect devices. Failure to do so may result in personal injury and/or equipment damage.



**ATTENTION:** To avoid a possible shock hazard caused by induced voltages, unused wires in the conduit must be grounded at both ends. For the same reason, if a drive sharing a conduit is being serviced or installed, all drives using this conduit should be disabled. This will help minimize the possible shock hazard from “cross coupled” power leads.

### Motor Cable Types Acceptable for 200-600 Volt Installations

#### General

A variety of cable types are acceptable for drive installations. For many installations, unshielded cable is adequate, provided it can be separated from sensitive circuits. As an approximate guide, allow a spacing of 0.3 meters (1 foot) for every 10 meters (32.8 feet) of length. In all cases, long parallel runs must be avoided. Do not use cable with an insulation thickness less than 15 mils (0.4 mm/0.015 in.).

UL installations in 50°C ambient must use 600V, 75°C or 90°C wire.

UL installations in 40°C ambient should use 600V, 75°C or 90°C wire.

#### Unshielded

THHN, THWN or similar wire is acceptable for drive installation in dry environments provided adequate free air space and/or conduit fill rates limits are provided. **Do not use THHN or similarly coated wire in wet areas.** Any wire chosen must have a minimum insulation thickness of 15 mils and should not have large variations in insulation concentricity.

#### Shielded

Location	Rating/Type	Description
Standard (Option 1)	600V, 75°C or 90°C (167°F or 194°F) RHH/RHW-2 Belden 29501-29507 or equivalent	<ul style="list-style-type: none"> <li>• Four tinned copper conductors with XLPE insulation</li> <li>• Foil shield and tinned copper drain wire with 85% braid coverage</li> <li>• PVC jacket</li> </ul>
Standard (Option 2)	Tray rated 600V, 75°C or 90°C (167°F or 194°F) RHH/RHW-2 Shawflex 2ACD/3ACD or equivalent	<ul style="list-style-type: none"> <li>• Three tinned copper conductors with XLPE insulation</li> <li>• 5 mil single helical copper tape (25% overlap min.) with three bare copper grounds in contact with shield</li> <li>• PVC jacket</li> </ul>
Class I & II; Division I & II	Tray rated 600V, 75°C or 90°C (167°F or 194°F) RHH/RHW-2	<ul style="list-style-type: none"> <li>• Three bare copper conductors with XLPE insulation with impervious corrugated continuously welded aluminum armor</li> <li>• Black sunlight resistant PVC jacket overall</li> <li>• Three copper grounds on #10 AWG and smaller</li> </ul>

## Reflected Wave Protection

The drive should be installed as close to the motor as possible. Installations with long motor cables may require the addition of external devices to limit voltage reflections at the motor (reflected wave phenomena). See [Table 1.E](#) for recommendations.

The reflected wave data applies to all frequencies 2 to 16 kHz.

For 240V ratings, reflected wave effects do not need to be considered.

**Table 1.E Maximum Cable Length Recommendations**

Reflected Wave		
380-480V Ratings	<b>Motor Insulation Rating</b>	<b>Motor Cable Only<sup>(1)</sup></b>
	1000 Vp-p	15 meters (49 feet)
	1200 Vp-p	40 meters (131 feet)
	1600 Vp-p	170 meters (558 feet)

<sup>(1)</sup> Longer cable lengths can be achieved by installing devices on the output of the drive. Consult factory for recommendations.

## Output Disconnect

The drive is intended to be commanded by control input signals that will start and stop the motor. A device that routinely disconnects then reapplies output power to the motor for the purpose of starting and stopping the motor should not be used. If it is necessary to disconnect power to the motor with the drive outputting power, an auxiliary contact should be used to simultaneously disable drive control run commands.

### Power Terminal Block

The drive utilizes a finger guard over the power wiring terminals. To remove:

1. Press in and hold the locking tab.
2. Slide finger guard down and out.

Replace the finger guard when wiring is complete.

Figure 1.4 Power Terminal Block (A Frame Shown)

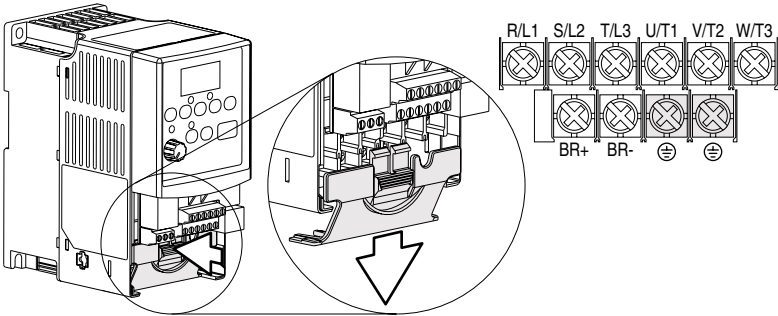

Terminal	Description
R/L1, S/L2	1-Phase Input
R/L1, S/L2, T/L3	3-Phase Input
U/T1	To Motor U/T1
V/T2	To Motor V/T2
W/T3	To Motor W/T3
BR+, BR-	Dynamic Brake Resistor Connection [0.75 kW (1 HP) ratings and higher]
⊕	Safety Ground - PE

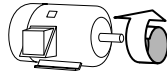

Switch any two motor leads to change forward direction.

Table 1.F Power Terminal Block Specifications

Frame	Maximum Wire Size <sup>(1)</sup>	Minimum Wire Size <sup>(1)</sup>	Torque
A	3.3 mm <sup>2</sup> (12 AWG)	0.8 mm <sup>2</sup> (18 AWG)	1.7-2.2 N-m (16-19 lb.-in.)
B	5.3 mm <sup>2</sup> (10 AWG)	1.3 mm <sup>2</sup> (16 AWG)	

<sup>(1)</sup> Maximum/minimum sizes that the terminal block will accept - these are not recommendations.

---

## I/O Wiring Recommendations

### Motor Start/Stop Precautions

---



**ATTENTION:** A contactor or other device that routinely disconnects and reapplies the AC line to the drive to start and stop the motor can cause drive hardware damage. The drive is designed to use control input signals that will start and stop the motor. If used, the input device must not exceed one operation per minute or drive damage can occur.



**ATTENTION:** The drive start/stop control circuitry includes solid-state components. If hazards due to accidental contact with moving machinery or unintentional flow of liquid, gas or solids exist, an additional hardwired stop circuit may be required to remove the AC line to the drive. When the AC line is removed, there will be a loss of any inherent regenerative braking effect that might be present - the motor will coast to a stop. An auxiliary braking method may be required.

---

Important points to remember about I/O wiring:

- Always use copper wire.
- Wire with an insulation rating of 600V or greater is recommended.
- Control and signal wires should be separated from power wires by at least 0.3 meters (1 foot).

**Important:** I/O terminals labeled “Common” are not referenced to the safety ground (PE) terminal and are designed to greatly reduce common mode interference.

---



**ATTENTION:** Driving the 4-20mA analog input from a voltage source could cause component damage. Verify proper configuration prior to applying input signals.

---

## Control Wire Types

**Table 1.G Recommended Control and Signal Wire<sup>(1)</sup>**

Wire Type(s)	Description	Minimum Insulation Rating
Belden 8760/9460 (or equiv.)	0.8 mm <sup>2</sup> (18 AWG), twisted pair, 100% shield with drain.	300V 60 degrees C (140 degrees F)
Belden 8770 (or equiv.)	0.8 mm <sup>2</sup> (18 AWG), 3 conductor, shielded for remote pot only.	

<sup>(1)</sup> If the wires are short and contained within a cabinet which has no sensitive circuits, the use of shielded wire may not be necessary, but is always recommended.

## I/O Terminal Block

**Table 1.H I/O Terminal Block Specifications**

Maximum Wire Size <sup>(1)</sup>	Minimum Wire Size <sup>(1)</sup>	Torque
1.3 mm <sup>2</sup> (16 AWG)	0.13 mm <sup>2</sup> (26 AWG)	0.5-0.8 N-m (4.4-7 lb.-in.)

<sup>(1)</sup> Maximum/minimum sizes that the terminal block will accept - these are not recommendations.

## Maximum Control Wire Recommendations

Do not exceed control wiring length of 30 meters (100 feet). Control signal cable length is highly dependent on electrical environment and installation practices. To improve noise immunity, the I/O terminal block Common must be connected to ground terminal/protective earth. If using the RS485 (DSI) port, I/O Terminal 16 should also be connected to ground terminal/protective earth.

**Figure 1.5 Control Wiring Block Diagram**

(1) **Important:** I/O Terminal 01 is always a coast to stop input except when P036 [Start Source] is set to “3-Wire” control. In three wire control, I/O Terminal 01 is controlled by P037 [Stop Mode]. All other stop sources are controlled by P037 [Stop Mode].

P036 [Start Source]	Stop	I/O Terminal 01 Stop
Keypad	Per P037	Coast
3-Wire	Per P037	Per P037
2-Wire	Per P037	Coast
RS485 Port	Per P037	Coast

**Important:** The drive is shipped with a jumper installed between I/O Terminals 01 and 11. Remove this jumper when using I/O Terminal 01 as a stop input.

(2) Two wire control shown. For three wire control use a momentary input on I/O Terminal 02 to command a start. Use a maintained input for I/O Terminal 03 to change direction.

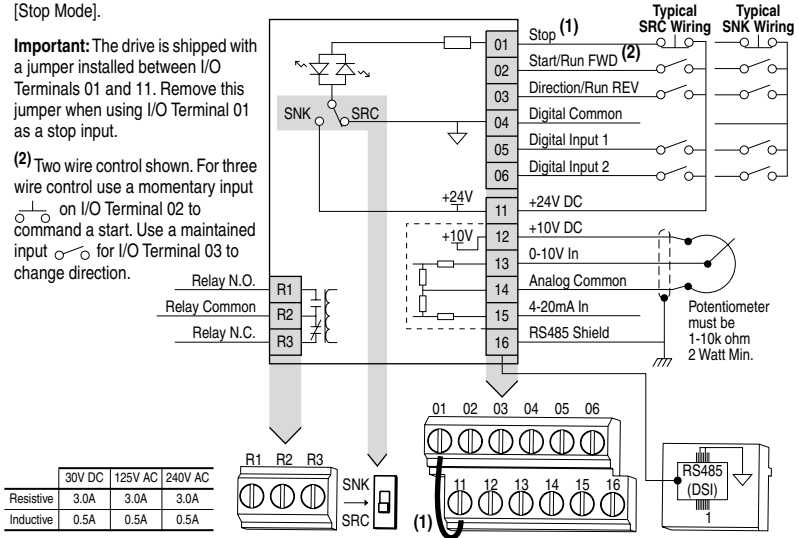

No.	Signal	Default	Description	Param.
R1	Relay N.O.	Fault	Normally open contact for output relay.	A055
R2	Relay Common	-	Common for output relay.	
R3	Relay N.C.	Fault	Normally closed contact for output relay.	A055

Sink/Source DIP Switch      Source (SRC)      Inputs can be wired as Sink (SNK) or Source (SRC) via DIP Switch setting.

No.	Signal	Default	Description	Param.
01	Stop (1)	Coast	The factory installed jumper or a normally closed input must be present for the drive to start.	P036 (1)
02	Start/Run FWD	Not Active	Command comes from the integral keypad by default. To disable reverse operation, see A095 [Reverse Disable].	P036, P037 P036, P037, A095
03	Direction/Run REV	Not Active		
04	Digital Common	-	For digital inputs. Electronically isolated with digital inputs from analog I/O.	
05	Digital Input 1	Preset Frequencies	Program with A051 [Digital In1 Sel].	A051
06	Digital Input 2	Preset Frequencies	Program with A052 [Digital In2 Sel].	A052
11	+24V DC	-	Drive supplied power for digital inputs. Maximum output current is 100mA.	
12	+10V DC	-	Drive supplied power for 0-10V external potentiometer. Maximum output current is 15mA.	P038
13	0-10V In (3)	Not Active	For external 0-10V input supply (input impedance = 100k ohm) or potentiometer wiper.	P038
14	Analog Common	-	For 0-10V In or 4-20mA In. Electronically isolated with analog inputs from digital I/O.	
15	4-20mA In	Not Active	For external 4-20mA input supply (input impedance = 250 ohm).	P038
16	RS485 (DSI) Shield	-	Terminal should be connected to safety ground - PE when using the RS485 (DSI) communications port.	

(3) Only one analog frequency source may be connected at a time. If more than one reference is connected at the same time, an undetermined frequency reference will result.

**I/O Wiring Examples**

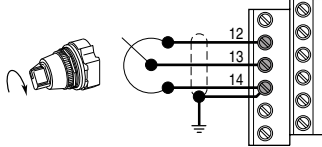
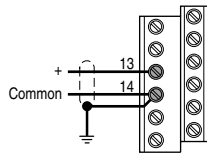
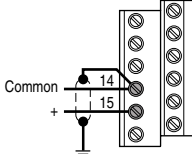
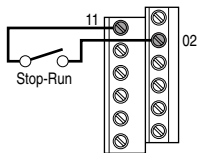
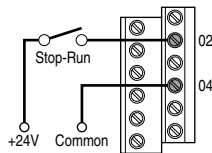
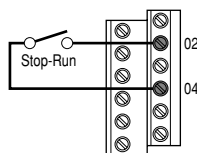
Input	Connection Example	
<p><b>Potentiometer</b>                      1-10k Ohm Pot.                      Recommended                      (2 Watt minimum)</p>	<p>P038 <a href="#">[Speed Reference]</a> = 2 "0-10V Input"</p> 	
<p><b>Analog Input</b>                      0 to +10V, 100k ohm impedance                      4-20 mA, 100 ohm impedance</p>	<p>Voltage                      P038 <a href="#">[Speed Reference]</a> = 2 "0-10V Input"</p> 	<p>Current                      P038 <a href="#">[Speed Reference]</a> = 2 "4-20mA Input"</p> 
<p><b>2 Wire SRC Control - Non-Reversing</b>                      P036 <a href="#">[Start Source]</a> = 2, 3 or 4                      Input must be active for the drive to run. When input is opened, the drive will stop as specified by P037 <a href="#">[Stop Mode]</a>.                      If desired, a User Supplied 24V DC power source can be used. Refer to the "External Supply (SRC)" example.</p>	<p>Internal Supply (SRC)</p> 	<p>External Supply (SRC)</p>  <p>Each digital input draws 6 mA.</p>
<p><b>2 Wire SNK Control - Non-Reversing</b></p>	<p>Internal Supply (SNK)</p> 	

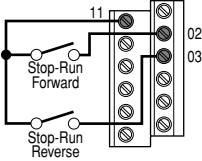
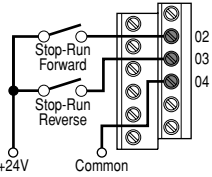
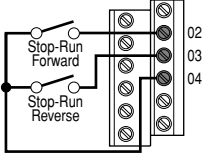
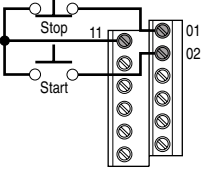
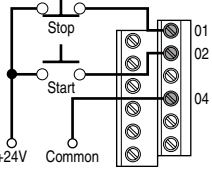
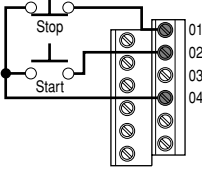
Input	Connection Example	
<p><b>2 Wire SRC Control - Run FWD/Run REV</b></p> <p>P036 [Start Source] = 2, 3 or 4</p> <p>Input must be active for the drive to run. When input is opened, the drive will stop as specified by P037 [Stop Mode].</p> <p>If both Run Forward and Run Reverse inputs are closed at the same time, an undetermined state could occur.</p>	<p>Internal Supply (SRC)</p> 	<p>External Supply (SRC)</p>  <p>Each digital input draws 6 mA.</p>
<p><b>2 Wire SNK Control - Run FWD/Run REV</b></p>	<p>Internal Supply (SNK)</p> 	
<p><b>3 Wire SRC Control - Non-Reversing</b></p> <p>P036 [Start Source] = 1</p> <p>A momentary input will start the drive. A stop input to I/O Terminal 01 will stop the drive as specified by P037 [Stop Mode].</p>	<p>Internal Supply (SRC)</p> 	<p>External Supply (SRC)</p>  <p>Each digital input draws 6 mA.</p>
<p><b>3 Wire SNK Control - Non-Reversing</b></p>	<p>Internal Supply (SNK)</p> 	

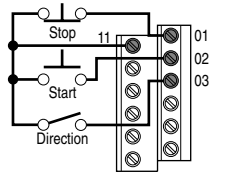
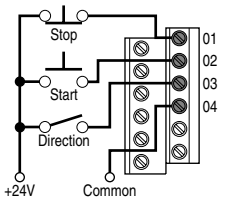
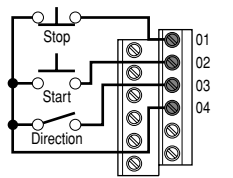
Input	Connection Example	
<p><b>3 Wire SRC Control - Reversing</b></p> <p>P036 [Start Source] = 1</p> <p>A momentary input will start the drive. A stop input to I/O Terminal 01 will stop the drive as specified by P037 [Stop Mode]. I/O Terminal 03 determines direction.</p>	<p>Internal Supply (SRC)</p> 	<p>External Supply (SRC)</p>  <p>Each digital input draws 6 mA.</p>
<p><b>3 Wire SNK Control - Reversing</b></p>	<p>Internal Supply (SNK)</p> 	

**Typical Multiple Drive Connection Examples**

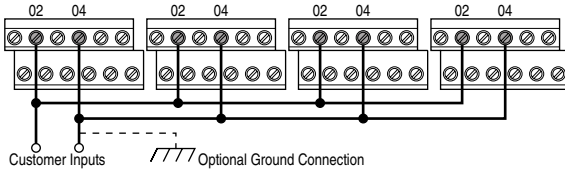
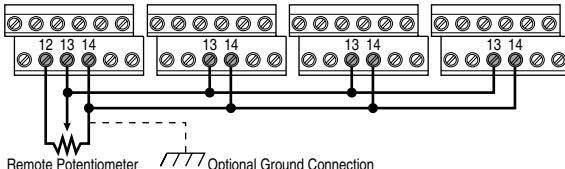
Input	Connection Example	
<p><b>Multiple Digital Input Connections</b></p> <p>Customer Inputs can be wired per External Supply (SRC) or Internal Supply (SNK) examples on <a href="#">page 1-15</a>.</p>	 <p>When connecting a single input such as Run, Stop, Reverse or Preset Speeds to multiple drives, it is important to connect I/O Terminal 04 common together for all drives. If they are to be tied into another common (such as earth ground or separate apparatus ground) only one point of the daisy chain of I/O Terminal 04 should be connected.</p>	
<p><b>Multiple Analog Connections</b></p>	 <p>When connecting a single potentiometer to multiple drives it is important to connect I/O Terminal 14 common together for all drives. I/O Terminal 14 common and I/O Terminal 13 (potentiometer wiper) should be daisy-chained to each drive. All drives must be powered up for the analog signal to be read correctly.</p>	

## Start and Speed Reference Control

The drive speed command can be obtained from a number of different sources. The source is normally determined by P038 [\[Speed Reference\]](#). However, when A051 or A052 [\[Digital Inx Sel\]](#) is set to option 2, 4, 5 or 6, and the digital input is active, A051 or A052 will override the speed reference commanded by P038 [\[Speed Reference\]](#). See the chart below for the override priority.

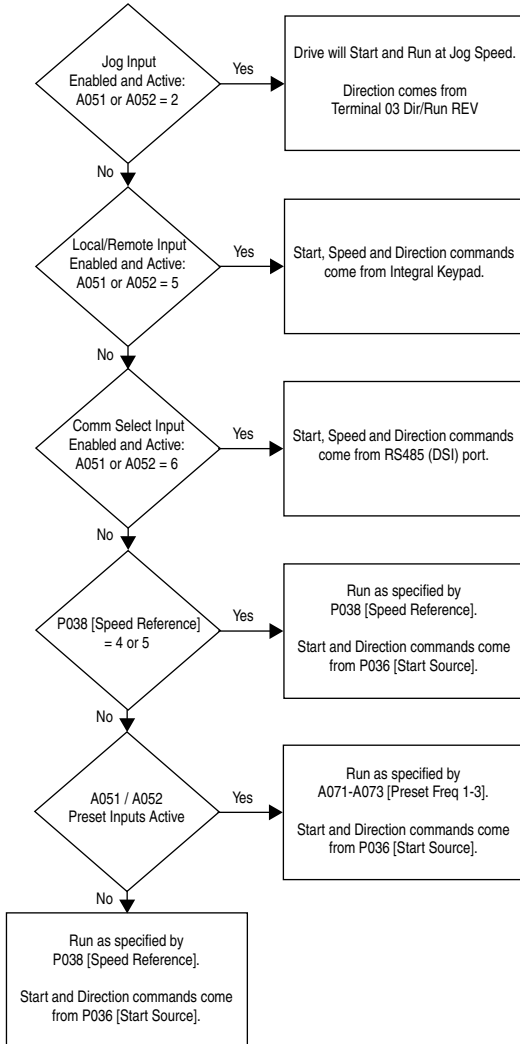

### Accel/Decel Selection

The selection of Accel/Decel rates can be made through digital inputs, RS485 (DSI) communications and/or parameters.

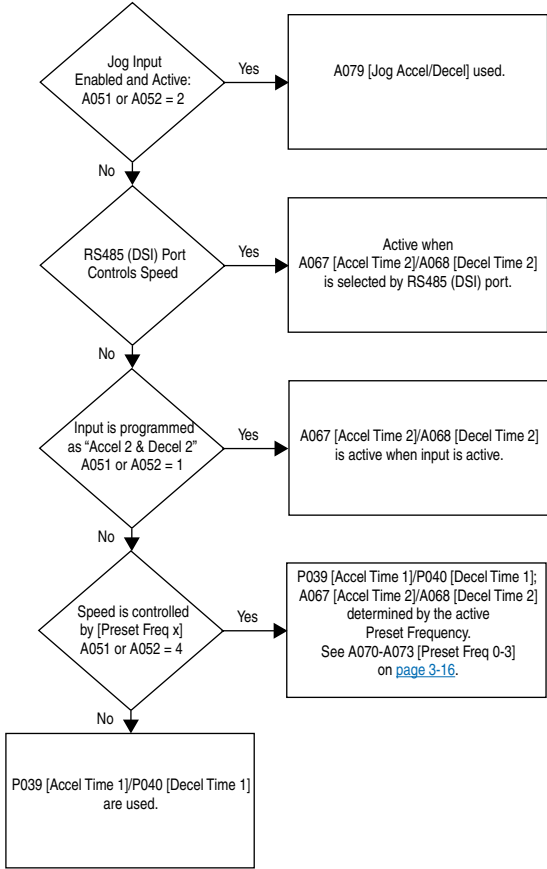

## EMC Instructions

### CE Conformity

Conformity with the Low Voltage (LV) Directive and Electromagnetic Compatibility (EMC) Directive has been demonstrated using harmonized European Norm (EN) standards published in the Official Journal of the European Communities. PowerFlex Drives comply with the EN standards listed below when installed according to the User Manual.

CE Declarations of Conformity are available online at:

<http://www.ab.com/certification/ce/docs>.

### Low Voltage Directive (73/23/EEC)

- EN50178 Electronic equipment for use in power installations

### EMC Directive (89/336/EEC)

- EN61800-3 Adjustable speed electrical power drive systems Part 3: EMC product standard including specific test methods.

### General Notes

- If the plastic top panel is removed or the optional conduit box is not installed, the drive must be installed in an enclosure with side openings less than 12.5 mm (0.5 in.) and top openings less than 1.0 mm (0.04 in.) to maintain compliance with the LV Directive.
- The motor cable should be kept as short as possible in order to avoid electromagnetic emission as well as capacitive currents.
- Use of line filters in ungrounded systems is not recommended.
- Conformity of the drive with CE EMC requirements does not guarantee an entire machine installation complies with CE EMC requirements. Many factors can influence total machine/installation compliance.

### Essential Requirements for CE Compliance

Conditions 1-3 listed below **must be** satisfied for PowerFlex drives to meet the requirements of **EN61800-3**.

1. Grounding as described in [Figure 1.6](#). Refer to [page 1-5](#) for additional grounding recommendations.
2. Output power, control (I/O) and signal wiring must be braided, shielded cable with a coverage of 75% or better, metal conduit or equivalent attenuation.
3. Allowable cable length in [Table 1.1](#) is not exceeded.

**Table 1.1 Allowable Cable Length**

Filter Type	EN61800-3 First Environment Restricted Distribution or Second Environment <sup>(2)</sup>	EN61800-3 First Environment Unrestricted Distribution <sup>(3)</sup>
Integral	10 meters (33 feet)	1 meter (3 feet)
External - S Type <sup>(1)</sup>	10 meters (33 feet)	1 meter (3 feet)
External - L Type <sup>(1)</sup>	100 meters (328 feet)	5 meters (16 feet)

<sup>(1)</sup> Refer to [Appendix B](#) for details on optional external filters.

<sup>(2)</sup> Equivalent to EN55011 Class A.

<sup>(3)</sup> Equivalent to EN55011 Class B.

**Figure 1.6 Connections and Grounding**

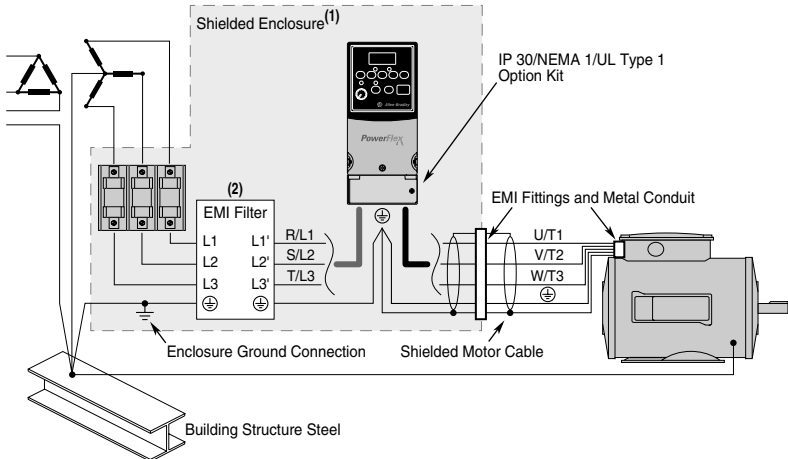

<sup>(1)</sup> First Environment Unrestricted Distribution installations require a shielded enclosure. Keep wire length as short as possible between the enclosure entry point and the EMI filter.

<sup>(2)</sup> Integral EMI filters are available on 240V, 1-Phase drives.

**EN61000-3-2**

- 0.75 kW (1 HP) 240V 1-Phase and 3-Phase drives and 0.37 kW (0.5 HP) 240V 1-Phase drives are suitable for installation on a private low voltage power network. Installations on a public low voltage power network may require additional external harmonic mitigation.
- Other drive ratings meet the current harmonic requirements of EN61000-3-2 without additional external mitigation.

**Notes:**

---

# Start Up

This chapter describes how to start up the PowerFlex 4 Drive. To simplify drive setup, the most commonly programmed parameters are organized in a single Basic Program Group.

**Important:** Read the *General Precautions* section before proceeding.



**ATTENTION:** Power must be applied to the drive to perform the following start-up procedures. Some of the voltages present are at incoming line potential. To avoid electric shock hazard or damage to equipment, only qualified service personnel should perform the following procedure. Thoroughly read and understand the procedure before beginning. If an event does not occur while performing this procedure, **Do Not Proceed. Remove All Power** including user supplied control voltages. User supplied voltages may exist even when main AC power is not applied to the drive. Correct the malfunction before continuing.

---

## Prepare For Drive Start-Up

### Before Applying Power to the Drive

- 1. Confirm that all inputs are connected to the correct terminals and are secure.
- 2. Verify that AC line power at the disconnect device is within the rated value of the drive.
- 3. Verify that any digital control power is 24 volts.
- 4. Verify that the Sink (SNK)/Source (SRC) Setup DIP Switch is set to match your control wiring scheme. See [Figure 1.5 on page 1-13](#) for location.

**Important:** The default control scheme is Source (SRC). The Stop terminal is jumpered (I/O Terminals 01 and 11) to allow starting from the keypad. If the control scheme is changed to Sink (SNK), the jumper must be removed from I/O Terminals 01 and 11 and installed between I/O Terminals 01 and 04.

- 5. Verify that the Stop input is present or the drive will not start.

**Important:** If I/O Terminal 01 is used as a stop input, the jumper between I/O Terminals 01 and 11 must be removed.

### Applying Power to the Drive

- ❑ 6. Apply AC power and control voltages to the drive.
- ❑ 7. Familiarize yourself with the integral keypad features (see [page 2-3](#)) before setting any Program Group parameters.

### Start, Stop, Direction and Speed Control

Factory default parameter values allow the drive to be controlled from the integral keypad. No programming is required to start, stop, change direction and control speed directly from the integral keypad.

**Important:** To disable reverse operation, see A095 [\[Reverse Disable\]](#).

If a fault appears on power up, refer to [Fault Descriptions on page 4-3](#) for an explanation of the fault code.

## Integral Keypad

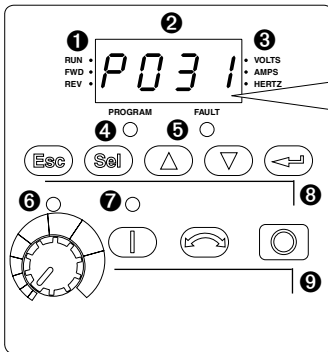

Menu	Description
<i>d</i>	<b>Display Group (View Only)</b> Consists of commonly viewed drive operating conditions.
<i>P</i>	<b>Basic Program Group</b> Consists of most commonly used programmable functions.
<i>A</i>	<b>Advanced Program Group</b> Consists of remaining programmable functions.
<i>F</i>	<b>Fault Designator</b> Consists of list of codes for specific fault conditions. Displayed only when fault is present.







No.	LED	LED State	Description
1	Run/Direction Status	Steady Red	Indicates drive is running and commanded motor direction.
		Flashing Red	Drive has been commanded to change direction. Indicates actual motor direction while decelerating to zero.
2	Alphanumeric Display	Steady Red	Indicates parameter number, parameter value, or fault code.
		Flashing Red	Single digit flashing indicates that digit can be edited. All digits flashing indicates a fault condition.
3	Displayed Units	Steady Red	Indicates the units of the parameter value being displayed.
4	Program Status	Steady Red	Indicates parameter value can be changed.
5	Fault Status	Flashing Red	Indicates drive is faulted.
6	Pot Status	Steady Green	Indicates potentiometer on Integral Keypad is active.
7	Start Key Status	Steady Green	Indicates Start key on Integral Keypad is active. The Reverse key is also active unless disabled by A095 <a href="#">[Reverse Disable]</a>

No.	Key	Name	Description
8		Escape	Back one step in programming menu. Cancel a change to a parameter value and exit Program Mode.
		Select	Advance one step in programming menu. Select a digit when viewing parameter value.
		Up Arrow Down Arrow	Scroll through groups and parameters. Increase/decrease the value of a flashing digit.
		Enter	Advance one step in programming menu. Save a change to a parameter value.
9		Potentiometer	Used to control speed of drive. Default is active. Controlled by parameter P038 <a href="#">[Speed Reference]</a> .
		Start	Used to start the drive. Default is active. Controlled by parameter P036 <a href="#">[Start Source]</a> .
		Reverse	Used to reverse direction of the drive. Default is active. Controlled by parameters P036 <a href="#">[Start Source]</a> and A095 <a href="#">[Reverse Disable]</a> .
		Stop	Used to stop the drive or clear a fault. This key is always active. Controlled by parameter P037 <a href="#">[Stop Mode]</a> .

## Viewing and Editing Parameters

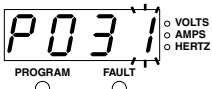
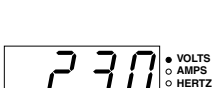
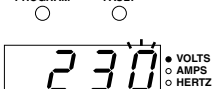
The last user-selected Display Group parameter is saved when power is removed and is displayed by default when power is reapplied.

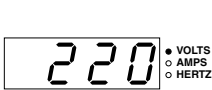
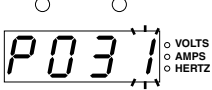
The following is an example of basic integral keypad and display functions. This example provides basic navigation instructions and illustrates how to program the first Program Group parameter.

Step	Key(s)	Example Displays
1. When power is applied, the last user-selected Display Group parameter number is briefly displayed with flashing characters. The display then defaults to that parameter's current value. (Example shows the value of d001 [Output Freq] with the drive stopped.)		
2. Press Esc once to display the Display Group parameter number shown on power-up. The parameter number will flash.	Esc	
3. Press Esc again to enter the group menu. The group menu letter will flash.	Esc	
4. Press the Up Arrow or Down Arrow to scroll through the group menu (d, P and A).	▲ or ▼	
5. Press Enter or Sel to enter a group. The right digit of the last viewed parameter in that group will flash.	← or Sel	
6. Press the Up Arrow or Down Arrow to scroll through the parameters that are in the group.	▲ or ▼	
7. Press Enter or Sel to view the value of a parameter. If you do not want to edit the value, press Esc to return to the parameter number.	← or Sel	
8. Press Enter or Sel to enter program mode to edit the parameter value. The right digit will flash and the Program LED will illuminate if the parameter can be edited.	← or Sel	
9. Press the Up Arrow or Down Arrow to change the parameter value. If desired, press Sel to move from digit to digit or bit to bit. The digit or bit that you can change will flash.	▲ or ▼	
10. Press Esc to cancel a change. The digit will stop flashing, the previous value is restored and the Program LED will turn off. Or Press Enter to save a change. The digit will stop flashing and the Program LED will turn off.	Esc  ←	
11. Press Esc to return to the parameter list. Continue to press Esc to back out of the programming menu. If pressing Esc does not change the display, then d001 [Output Frequency] is displayed. Press Enter or Sel to enter the group menu.	Esc	

The Basic Program Group ([page 3-8](#)) contains the most commonly changed parameters.

## Programming and Parameters

Chapter 3 provides a complete listing and description of the PowerFlex 4 parameters. Parameters are programmed (viewed/edited) using the integral keypad. As an alternative, programming can also be performed using DriveExplorer™ or DriveExecutive™ software, a personal computer and a serial converter module. Refer to [Appendix B](#) for catalog numbers.

For information on...	See page...
<a href="#">About Parameters</a>	<a href="#">3-1</a>
<a href="#">Parameter Organization</a>	<a href="#">3-2</a>
<a href="#">Basic Program Group</a>	<a href="#">3-8</a>
<a href="#">Advanced Program Group</a>	<a href="#">3-13</a>
<a href="#">Parameter Cross Reference – by Name</a>	<a href="#">3-26</a>

### About Parameters

To configure a drive to operate in a specific way, drive parameters may have to be set. Three types of parameters exist:

- **ENUM**  
ENUM parameters allow a selection from 2 or more items. Each item is represented by a number.
- **Numeric Parameters**  
These parameters have a single numerical value (i.e. 0.1 Volts).
- **Bit Parameters**  
Bit parameters have four individual bits associated with features or conditions. If the bit is 0, the feature is off or the condition is false. If the bit is 1, the feature is on or the condition is true.

Some parameters are marked as follows.

 = Stop drive before changing this parameter.

 = 32 bit parameter. Parameters marked 32 bit will have two parameter numbers when using RS485 communications and programming software.

## Parameter Organization

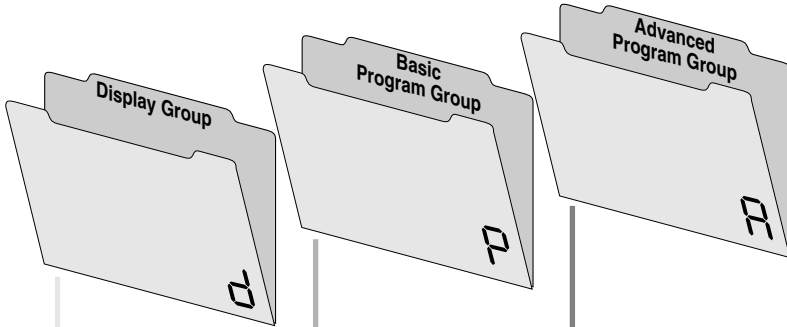

**See page 3-3**

Output Freq d001  
 Commanded Freq d002  
 Output Current d003  
 Output Voltage d004  
 DC Bus Voltage d005  
 Drive Status d006  
 Fault 1 Code d007  
 Fault 2 Code d008  
 Fault 3 Code d009  
 Process Display d010  
 Control Source d012  
 Contrl In Status d013  
 Dig In Status d014  
 Comm Status d015  
 Control SW Ver d016  
 Drive Type d017  
 Elapsed Run Time d018  
 Testpoint Data d019  
 0-10V Analog Input d020  
 4-20mA Analog Input d021

**See page 3-8**

Motor NP Volts P031  
 Motor NP Hertz P032  
 Motor OL Current P033  
 Minimum Freq P034  
 Maximum Freq P035  
 Start Source P036  
 Stop Mode P037  
 Speed Reference P038  
 Accel Time 1 P039  
 Decel Time 1 P040  
 Reset To Defaults P041

**See page 3-13**

Digital In1 Sel A051  
 Digital In2 Sel A052  
 Relay Out Sel A055  
 Relay Out Level A056  
 Accel Time 2 A067  
 Decel Time 2 A068  
 Internal Freq A069  
 Preset Freq 0 A070  
 Preset Freq 1 A071  
 Preset Freq 2 A072  
 Preset Freq 3 A073  
 Jog Frequency A078  
 Jog Accel/Decel A079  
 DC Brake Time A080  
 DC Brake Level A081  
 DB Resistor Sel A082  
 S Curve % A083  
 Start Boost A084  
 Maximum Voltage A088  
 Current Limit A089  
 Motor OL Select A090  
 PWM Frequency A091  
 Auto Rstrt Tries A092  
 Auto Rstrt Delay A093  
 Start At PowerUp A094  
 Reverse Disable A095  
 Flying Start En A096  
 Compensation A097  
 SW Current Trip A098  
 Process Factor A099  
 Fault Clear A100  
 Program Lock A101  
 Testpoint Sel A102  
 Comm Data Rate A103  
 Comm Node Addr A104  
 Comm Loss Action A105  
 Comm Loss Time A106  
 Comm Format A107  
 0-10V Analog Input Low A110  
 0-10V Analog Input High A111  
 4-20mA Analog Input Low A112  
 4-20mA Analog Input High A113  
 Slip Compensation A114

## Display Group

### d001 [Output Freq]

Related Parameter(s): [d002](#), [d010](#), [P034](#), [P035](#)

Output frequency present at T1, T2 & T3 (U, V & W).

<b>Values</b>	Default	Read Only
	Min/Max:	0.0/P035 <a href="#">[Maximum Freq]</a>
	Display:	0.1 Hz

### d002 [Commanded Freq]

Related Parameter(s): [d001](#), [P034](#), [P035](#), [P036](#)

Value of the active frequency command. Displays the commanded frequency even if the drive is not running.

**Important:** The frequency command can come from a number of sources. Refer to [Start and Speed Reference Control on page 1-17](#) for details.

<b>Values</b>	Default	Read Only
	Min/Max:	0.0/P035 <a href="#">[Maximum Freq]</a>
	Display:	0.1 Hz

### d003 [Output Current]

The output current present at T1, T2 & T3 (U, V & W).

<b>Values</b>	Default	Read Only
	Min/Max:	0.00/Drive Rated Amps × 2
	Display:	0.01 Amps

### d004 [Output Voltage]

Related Parameter(s): [P031](#), [A084](#), [A088](#)

Output voltage present at terminals T1, T2 & T3 (U, V & W).

<b>Values</b>	Default	Read Only
	Min/Max:	0/Drive Rated Volts
	Display:	1 VAC

### d005 [DC Bus Voltage]

Present DC bus voltage level.

<b>Values</b>	Default	Read Only
	Min/Max:	Based on Drive Rating
	Display:	1 VDC

## Display Group *(continued)*

### d006 [Drive Status]

Related Parameter(s): [A095](#)

Present operating condition of the drive.

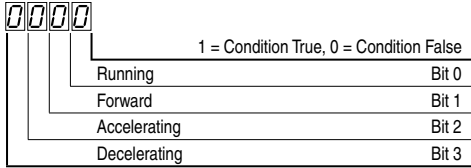

<b>Values</b>	Default	Read Only
	Min/Max:	0/1
	Display:	1

### d007 [Fault 1 Code]

### d008 [Fault 2 Code]

### d009 [Fault 3 Code]

A code that represents a drive fault. The codes will appear in these parameters in the order they occur (d007 [\[Fault 1 Code\]](#) = the most recent fault). Repetitive faults will only be recorded once.

Refer to [Chapter 4](#) for fault code descriptions.

<b>Values</b>	Default	Read Only
	Min/Max:	F2/F122
	Display:	F1

 32 bit parameter.

### d010 [Process Display]

Related Parameter(s): [d001](#), [A099](#)

The output frequency scaled by A099 [\[Process Factor\]](#).

$$\text{Output Freq} \times \text{Process Factor} = \text{Process Display}$$

<b>Values</b>	Default	Read Only
	Min/Max:	0.00/9999
	Display:	0.01 – 1

## Display Group *(continued)*

### d012 [Control Source]

 Related Parameter(s): [P036](#), [P038](#), [A051](#), [A052](#)

Displays the active source of the Start Command and Speed Command which are normally defined by the settings of P036 [\[Start Source\]](#) and P038 [\[Speed Reference\]](#) but may be overridden by digital inputs. Refer to the flowcharts on pages [1-17](#) and [1-18](#) for details.

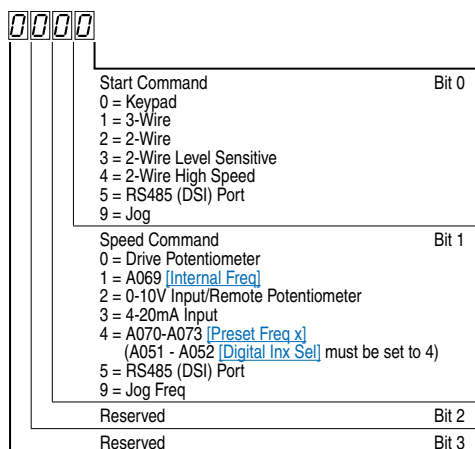

Values	Default	Read Only
Min/Max:		0/9
Display:		1

### d013 [Contrl In Status]

 Related Parameter(s): [d002](#), [P034](#), [P035](#)

Status of the control terminal block control inputs.

**Important:** Actual control commands may come from a source other than the control terminal block.

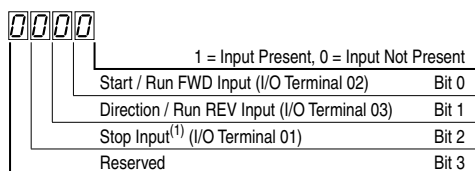

<sup>(1)</sup> The stop input must be present in order to start the drive. When this bit is a 1 the drive can be started. When this bit is a 0 the drive will stop.

Values	Default	Read Only
Min/Max:		0/1
Display:		1

## Display Group *(continued)*

### d014 [Dig In Status]

Related Parameter(s): [A051](#), [A052](#)

Status of the control terminal block digital inputs.

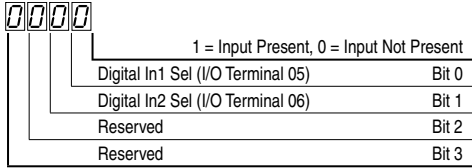

<b>Values</b>	Default	Read Only
	Min/Max:	0/1
	Display:	1

### d015 [Comm Status]

Related Parameter(s): [A103](#) thru [A107](#)

Status of the communications device.

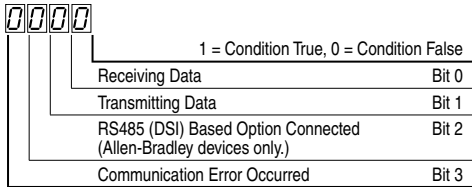

<b>Values</b>	Default	Read Only
	Min/Max:	0/1
	Display:	1

### d016 [Control SW Ver]

Main Control Board software version.

<b>Values</b>	Default	Read Only
	Min/Max:	1.00/99.99
	Display:	0.01

### d017 [Drive Type]

Used by Rockwell Automation field service personnel.

<b>Values</b>	Default	Read Only
	Min/Max:	1001/9999
	Display:	1

## Display Group *(continued)*

### d018 [Elapsed Run Time]

Accumulated time drive is outputting power. Time is displayed in 10 hour increments.

<b>Values</b>	Default	Read Only
	Min/Max:	0/9999 Hrs
	Display:	1 = 10 Hrs

### d019 [Testpoint Data]

Related Parameter(s): [A102](#)

The present value of the function selected in A102 [\[Testpoint Sel\]](#).

<b>Values</b>	Default	Read Only
	Min/Max:	0/FFFF
	Display:	1 Hex

### d020 [0-10V Analog Input]

Related Parameter(s): [A110](#), [A111](#)

The present value of the voltage at I/O Terminal 13 (100.0% = 10 volts).

<b>Values</b>	Default	Read Only
	Min/Max:	0.0/100.0%
	Display:	0.1%

### d021 [4-20mA Analog Input]

Related Parameter(s): [A112](#), [A113](#)

The present value of the current at I/O Terminal 15 (0.0% = 4mA, 100.0% = 20mA).

<b>Values</b>	Default	Read Only
	Min/Max:	0.0/100.0%
	Display:	0.1%

## Basic Program Group

 Stop drive before changing this parameter.

### P031 [Motor NP Volts] Related Parameter(s): [A084](#)

Set to the motor nameplate rated volts.

<b>Values</b>	Default	Based on Drive Rating
	Min/Max:	20/Drive Rated Volts
	Display:	1 VAC

 Stop drive before changing this parameter.

### P032 [Motor NP Hertz] Related Parameter(s): [A084](#)

Set to the motor nameplate rated frequency.

<b>Values</b>	Default	60 Hz
	Min/Max:	10/240 Hz
	Display:	1 Hz

### P033 [Motor OL Current] Related Parameter(s): [A089](#), [A090](#), [A098](#)

Set to the maximum allowable motor current.

The drive will fault on an F7 Motor Overload if the value of this parameter is exceeded by 150% for 60 seconds or 200% for 3 seconds.

<b>Values</b>	Default	Based on Drive Rating
	Min/Max:	0.0/(Drive Rated Amps × 2)
	Display:	0.1 Amps

### P034 [Minimum Freq] Related Parameter(s): [P035](#)

Sets the lowest frequency the drive will output continuously.

<b>Values</b>	Default	0.0 Hz
	Min/Max:	0.0/240.0 Hz
	Display:	0.1 Hz

 Stop drive before changing this parameter.

### P035 [Maximum Freq] Related Parameter(s): [P034](#)

Sets the highest frequency the drive will output.

<b>Values</b>	Default	60 Hz
	Min/Max:	0/240 Hz
	Display:	1 Hz

## Basic Program Group (*continued*)

 Stop drive before changing this parameter.

### P036 [Start Source]

Related Parameter(s): [d012](#)

Sets the control scheme used to start the drive.

Refer to [Start and Speed Reference Control on page 1-17](#) for details about how other drive settings can override the setting of this parameter.

**Important:** For all settings except option 3, the drive must receive a leading edge from the start input for the drive to start after a stop input, loss of power or fault condition.

<b>Options</b>	<b>0</b>	“Keypad” (Default)	<ul style="list-style-type: none"> <li>Integral keypad controls drive operation.</li> <li>I/O Terminal 1 “Stop” = coast to stop.</li> <li>When active, the Reverse key is also active unless disabled by A095 <a href="#">[Reverse Disable]</a>.</li> </ul>
	<b>1</b>	“3-Wire”	I/O Terminal 1 “Stop” = stop according to the value set in P037 <a href="#">[Stop Mode]</a> .
	<b>2</b>	“2-Wire”	I/O Terminal 1 “Stop” = coast to stop.
	<b>3</b>	“2-Wire Level Sensitive”	Drive will restart after a “Stop” command when: <ul style="list-style-type: none"> <li>Stop is removed and</li> <li>Start is held active</li> </ul>



**ATTENTION:** Hazard of injury exists due to unintended operation. When P036 [Start Source] is set to option 3, and the Run input is maintained, the Run inputs do not need to be toggled after a Stop input for the drive to run again. A Stop function is provided only when the Stop input is active (open).

	<b>4</b>	“2-Wire High Speed”	<b>Important:</b> There is greater potential voltage on the output terminals when using this option. <ul style="list-style-type: none"> <li>Outputs are kept in a ready-to-run state. The drive will respond to a “Start” command within 10 ms.</li> <li>I/O Terminal 1 “Stop” = coast to stop.</li> </ul>
	<b>5</b>	“RS485 (DSI) Port”	<ul style="list-style-type: none"> <li>Remote communications.</li> <li>I/O Terminal 1 “Stop” = coast to stop.</li> </ul>

**Important:** When commanding Jog via the RS485 communications port on drives with firmware version 1.02 or earlier, the Jog command will follow the commanded direction from I/O Terminal 03. On firmware versions 1.03 and later, the commanded direction will be provided via the RS485 communications port.

**Important:** When sending a continuous start command via the RS485 communications port on drives with firmware version 1.02 or earlier, a maintained stop input is required to stop the drive. Once the stop input is inactive, the drive will restart. On firmware versions 1.03 and later, once a stop input is received, the start command must transition from high to low to high for the drive to start.

## Basic Program Group (continued)

### P037 [Stop Mode]

Related Parameter(s): [P036](#), [A080](#), [A081](#), [A082](#)

Active stop mode for all stop sources [e.g. keypad, run forward (I/O Terminal 02), run reverse (I/O Terminal 03), RS485 port] except as noted below.

**Important:** I/O Terminal 01 is always a coast to stop input except when P036 [Start Source] is set for "3-Wire" control. When in three wire control, I/O Terminal 01 is controlled by P037 [Stop Mode].

<b>Options</b>	<b>0</b>	"Ramp, Clear Fault" <sup>(1)</sup> (Default)	Ramp to Stop. "Stop" command clears active fault.
	<b>1</b>	"Coast, Clear Fault" <sup>(1)</sup>	Coast to Stop. "Stop" command clears active fault.
	<b>2</b>	"DC Brake, Clear Fault" <sup>(1)</sup>	DC Injection Braking Stop. "Stop" command clears active fault.
	<b>3</b>	"DC Brake w/Shutoff, Clear Fault" <sup>(1)</sup>	DC Injection Braking Stop with Auto Shutoff. <ul style="list-style-type: none"> <li>• Standard DC Injection Braking for value set in A080 <a href="#">[DC Brake Time]</a>.</li> <li>OR</li> <li>• Drive shuts off if the drive detects that the motor is stopped.</li> </ul> "Stop" command clears active fault.
	<b>4</b>	"Ramp"	Ramp to Stop.
	<b>5</b>	"Coast"	Coast to Stop.
	<b>6</b>	"DC Brake"	DC Injection Braking Stop.
	<b>7</b>	"DC Brake w/Shutoff"	DC Injection Braking Stop with Auto Shutoff. <ul style="list-style-type: none"> <li>• Standard DC Injection Braking for value set in A080 <a href="#">[DC Brake Time]</a>.</li> <li>OR</li> <li>• Drive shuts off if current limit is exceeded.</li> </ul>

<sup>(1)</sup> Stop input also clears active fault.

## Basic Program Group (continued)

### P038 [Speed Reference]

Related Parameter(s): [d012](#), [A069](#), [A070](#), [A071](#), [A072](#), [A073](#)

Sets the source of the speed reference to the drive.

**Important:** When A051 or A052 [[Digital Inx Sel](#)] is set to option 2, 4, 5 or 6, and the digital input is active, A051 or A052 will override the speed reference commanded by this parameter.

Refer to [Start and Speed Reference Control on page 1-17](#) for details about how other drive settings can override the setting of this parameter.

<b>Options</b>	<b>0</b>	“Drive Potentiometer” (Default)	Internal frequency command from the potentiometer on the integral keypad.
	<b>1</b>	“Internal Freq”	Internal frequency command from A069 [ <a href="#">Internal Freq</a> ].
	<b>2</b>	“0-10V Input/Remote Potentiometer”	External frequency command from the 0-10V analog input or remote potentiometer.
	<b>3</b>	“4-20mA Input”	External frequency command from the 4-20mA analog input.
	<b>4</b>	“Preset Freq 0-3”	External frequency command as defined by A070 - A073 [ <a href="#">Preset Freq x</a> ] when A051 and A052 [ <a href="#">Digital Inx Sel</a> ] are programmed as “Preset Frequencies” and the digital inputs are active.
	<b>5</b>	“RS485 (DSI) Port”	External frequency command from the communications port.

### P039 [Accel Time 1]

Related Parameter(s): [P038](#), [P040](#), [A051](#), [A052](#), [A067](#)

Sets the rate of acceleration for all speed increases.

$$\frac{\text{Maximum Freq}}{\text{Accel Time}} = \text{Accel Rate}$$

<b>Values</b>	Default	10.0 Secs
	Min/Max:	0.0/600.0 Secs
	Display:	0.1 Secs

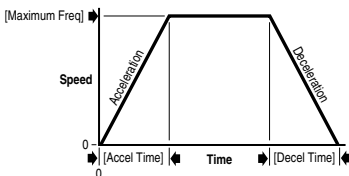

## Basic Program Group *(continued)*

### P040 [Decel Time 1]

Related Parameter(s): [P038](#), [P039](#), [A051](#), [A052](#), [A068](#)

Sets the rate of deceleration for all speed decreases.

$$\frac{\text{Maximum Freq}}{\text{Decel Time}} = \text{Decel Rate}$$

<b>Values</b>	Default	10.0 Secs
	Min/Max:	0.1/600.0 Secs
	Display:	0.1 Secs

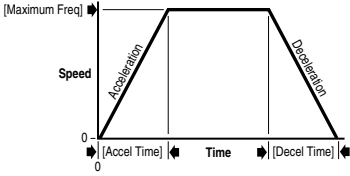

Stop drive before changing this parameter.

### P041 [Reset To Defaults]

Resets all parameter values to factory defaults.

<b>Options</b>	0 "Idle State" (Default)	
	1 "Reset Defaults"	<ul style="list-style-type: none"> <li>After the reset function is complete, this parameter will set itself back to "0".</li> <li>Causes an F48 <a href="#">Params Defaulted</a> fault.</li> </ul>

## Advanced Program Group

 Stop drive before changing this parameter.

**A051 [Digital In1 Sel]** Related Parameter(s): [A067](#), [A068](#), [A070-A073](#), [A078](#), [A079](#)  
(I/O Terminal 5)

**A052 [Digital In2 Sel]**  
(I/O Terminal 6)

Selects the function for the digital inputs. Refer to the flowchart on [page 1-17](#) for more information on speed reference control priority.

<b>Options</b>	<b>0</b>	“Not Used”	
	<b>1</b>	“Accel 2 & Decel 2”	<ul style="list-style-type: none"> <li>Can only be tied to one input.</li> <li>When active, A067 <a href="#">[Accel Time 2]</a> and A068 <a href="#">[Decel Time 2]</a> are used for all ramp rates except Jog.</li> </ul> <p>Refer to the flowchart on <a href="#">page 1-18</a> for more information on Accel/Decel selection.</p>
	<b>2</b>	“Jog”	<ul style="list-style-type: none"> <li>When input is present, drive accelerates according to the value set in A079 <a href="#">[Jog Accel/Decel]</a> and ramps to the value set in A078 <a href="#">[Jog Frequency]</a>.</li> <li>When input is removed, drive ramps to a stop according to the value set in A079 <a href="#">[Jog Accel/Decel]</a>.</li> <li>A valid “Start” command will override this input.</li> </ul>
	<b>3</b>	“Auxiliary Fault”	When enabled, an F2 <a href="#">Auxiliary Input</a> fault will occur when the input is removed.
	<b>4</b>	“Preset Frequencies” (Default)	Refer to A070 - A073 <a href="#">[Preset Freq x]</a> . <b>Important:</b> Digital Input 1 or 2 has priority for frequency control when it is programmed as a Preset Speed and is active.
	<b>5</b>	“Local”	When active, sets integral keypad as start source and potentiometer on the integral keypad as speed source.
	<b>6</b>	“RS485 (DSI) Port”	<ul style="list-style-type: none"> <li>Can only be tied to one input.</li> <li>When active, sets communications device as default start/speed command source.</li> </ul>
	<b>7</b>	“Clear Fault”	When active, clears an active fault.

**A055 [Relay Out Sel]**

Related Parameter(s): [P033](#), [A056](#), [A092](#)

Sets the condition that changes the state of the output relay contacts.

<b>Options</b>	<b>0</b>	“Ready” (Not Faulted) Default	Relay changes state when power is applied. This indicates that the drive is ready for operation. Relay returns drive to shelf state when power is removed or a fault occurs.
	<b>1</b>	“At Frequency”	Drive reaches commanded frequency.
	<b>2</b>	“Motor Running”	Motor is receiving power from the drive.
	<b>3</b>	“Reverse”	Drive is commanded to run in reverse direction.
	<b>4</b>	“Motor Overload”	Motor overload condition exists.
	<b>5</b>	“Ramp Regulated”	Ramp regulator is modifying the programmed accel/decel times to avoid an overcurrent or overvoltage fault from occurring.
	<b>6</b>	“Above Frequency”	Drive exceeds the frequency (Hz) value set in A056 <a href="#">[Relay Out Level]</a> .
	<b>7</b>	“Above Current”	Drive exceeds the current (% Amps) value set in A056 <a href="#">[Relay Out Level]</a> .  <b>Important:</b> Value for A056 <a href="#">[Relay Out Level]</a> must be entered in percent of drive rated output current.
	<b>8</b>	“Above DC Bus Volts”	Drive exceeds the DC bus voltage value set in A056 <a href="#">[Relay Out Level]</a> .
	<b>9</b>	“Retries Exhausted”	Value set in A092 <a href="#">[Auto Rstrt Tries]</a> is exceeded.

## Advanced Program Group *(continued)*

 32 bit parameter.

### A056 [Relay Out Level]

Related Parameter(s): [A055](#)

Sets the trip point for the digital output relay if the value of A055 [\[Relay Out Sel\]](#) is 6, 7 or 8.

A055 Setting	Min/Max
6	0/240 Hz
7	0/180%
8	0/815 Volts

<b>Values</b>	Default	0.0
	Min/Max:	0.0/9999
	Display:	0.1 – 1

### A067 [Accel Time 2]

Related Parameter(s): [P039](#)

Sets the rate of acceleration for all speed increases except jog.

$$\frac{\text{Maximum Freq}}{\text{Accel Time}} = \text{Accel Rate}$$

<b>Values</b>	Default	20.0 Secs
	Min/Max:	0.0/600.0 Secs
	Display:	0.1 Secs

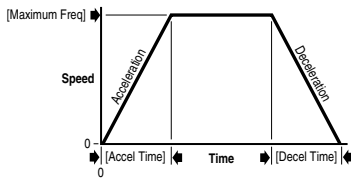

### A068 [Decel Time 2]

Related Parameter(s): [P040](#)

Sets the rate of deceleration for all speed decreases except jog.

$$\frac{\text{Maximum Freq}}{\text{Decel Time}} = \text{Decel Rate}$$

<b>Values</b>	Default	20.0 Secs
	Min/Max:	0.1/600.0 Secs
	Display:	0.1 Secs

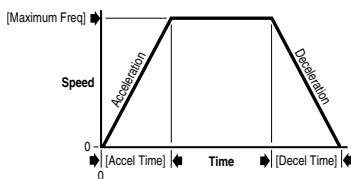

## Advanced Program Group (continued)

### A069 [Internal Freq]

Related Parameter(s): [P038](#)

Provides the frequency command to the drive when P038 [\[Speed Reference\]](#) is set to 1 "Internal Freq". When enabled, this parameter will change the frequency command in "real time" using the integral keypad Up Arrow or Down Arrow when in program mode.

**Important:** Once the desired command frequency is reached, the Enter key must be pressed to store this value to EEPROM memory. If the ESC key is used before the Enter key, the frequency will return to the original value following the normal accel/decel curve.

<b>Values</b>	Default	60.0 Hz
	Min/Max:	0.0/240.0 Hz
	Display:	0.1 Hz

### A070 [Preset Freq 0]<sup>(1)</sup>

Related Parameter(s): [P038](#), [A051](#), [A052](#)

### A071 [Preset Freq 1]

### A072 [Preset Freq 2]

### A073 [Preset Freq 3]

Provides a fixed frequency command value when A051 - A052 [\[Digital Inx Sel\]](#) is set to 4 "Preset Frequencies".

<sup>(1)</sup> To activate A070 [Preset Freq 0] set P038 [\[Speed Reference\]](#) to option 4 "Preset Freq 0-3".

<b>Values</b>	A070 Default	0.0 Hz
	A071 Default	5.0 Hz
	A072 Default	10.0 Hz
	A073 Default	20.0 Hz
	Min/Max:	0.0/240.0 Hz
	Display:	0.1 Hz

Input State of Digital In 1 (I/O Terminal 05)	Input State of Digital In 2 (I/O Terminal 06)	Frequency Source	Accel / Decel Parameter Used <sup>(2)</sup>
0	0	A070 [Preset Freq 0]	[Accel Time 1] / [Decel Time 1]
1	0	A071 [Preset Freq 1]	[Accel Time 1] / [Decel Time 1]
0	1	A072 [Preset Freq 2]	[Accel Time 2] / [Decel Time 2]
1	1	A073 [Preset Freq 3]	[Accel Time 2] / [Decel Time 2]

<sup>(2)</sup> When a Digital Input is set to "Accel 2 & Decel 2", and the input is active, that input overrides the settings in this table.

### A078 [Jog Frequency]

Related Parameter(s): [P035](#), [A051](#), [A052](#)

Sets the output frequency when a jog command is issued.

<b>Values</b>	Default	10.0 Hz
	Min/Max:	0.0/P035 <a href="#">[Maximum Freq]</a>
	Display:	0.1 Hz

## Advanced Program Group *(continued)*

### A079 [Jog Accel/Decel]

Sets the acceleration and deceleration time when a jog command is issued.

<b>Values</b>	Default	10.0 Secs
	Min/Max:	0.1/600.0 Secs
	Display:	0.1 Secs

### A080 [DC Brake Time]

Related Parameter(s): [A081](#)

Sets the length of time that DC brake current is “injected” into the motor. Refer to parameter A081 [[DC Brake Level](#)].

<b>Values</b>	Default	0.0 Secs
	Min/Max:	0.0/90.0 Secs
	Display:	0.1 Secs

### A081 [DC Brake Level]

Related Parameter(s): [P037](#), [A080](#)

Defines the maximum DC brake current, in amps, applied to the motor when P037 [[Stop Mode](#)] is set to either “Ramp” or “DC Brake”.

<b>Values</b>	Default	Drive Rated Amps $\times$ 0.05
	Min/Max:	0.0/(Drive Rated Amps $\times$ 1.8)
	Display:	0.1 Amps

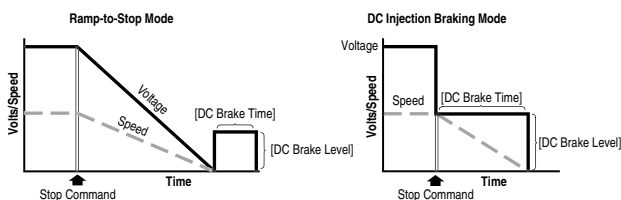

**ATTENTION:** If a hazard of injury due to movement of equipment or material exists, an auxiliary mechanical braking device must be used.



**ATTENTION:** This feature should not be used with synchronous or permanent magnet motors. Motors may be demagnetized during braking.

## Advanced Program Group (continued)

 Stop drive before changing this parameter.

### A082 [DB Resistor Sel]

Enables/disables external dynamic braking.

Setting	Min/Max
0	Disabled
1	AB Resistor (5% Duty Cycle)
2	No Protection (100% Duty Cycle)
3-99	Duty Cycle Limited (3% – 99% of Duty Cycle)

Values	Default	0
	Min/Max:	0/99
	Display:	1

### A083 [S Curve %]

Sets the percentage of acceleration or deceleration time that is applied to the ramp as S Curve. Time is added, 1/2 at the beginning and 1/2 at the end of the ramp.

Values	Default	0% (Disabled)
	Min/Max:	0/100%
	Display:	1%

#### Example:

Accel Time = 10 Seconds

S Curve Setting = 30%

S Curve Time =  $10 \times 0.3 = 3$  Seconds

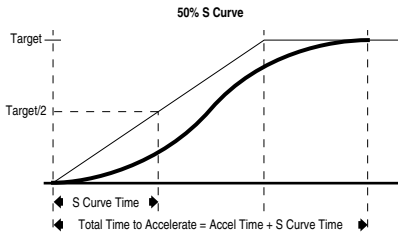
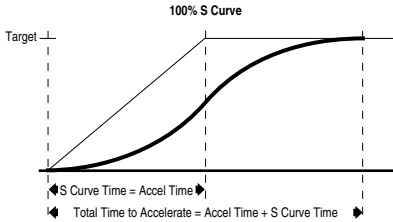

## Advanced Program Group *(continued)*

### A084 [Start Boost]

 Related Parameter(s): [P031](#)

 Sets the boost voltage (% of P031 [[Motor NP Volts](#)]) and redefines the Volts per Hz curve.<sup>(1)</sup>
<sup>(1)</sup> Drive may add additional voltage unless Option 5 is selected.

Options		
1	"30.0"	Variable Torque
2	"35.0"	
3	"40.0"	
4	"45.0"	
5	"0.0 no IR Comp"	
6	"0.0"	Constant Torque
7	"2.5" [Default for 3.7kW (5HP) Drives]	
8	"5.0" (Default)	
9	"7.5"	
10	"10.0"	
11	"12.5"	
12	"15.0"	
13	"17.5"	
14	"20.0"	

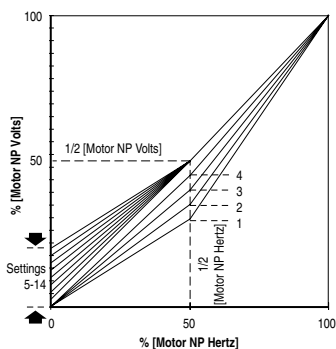

### A088 [Maximum Voltage]

Sets the highest voltage the drive will output.

Values	Default	Drive Rated Volts
	Min/Max:	20/Drive Rated Volts
	Display:	1 VAC

## Advanced Program Group *(continued)*

### A089 [Current Limit]

Maximum output current allowed before current limiting occurs.

<b>Values</b>	Default	Drive Rated Amps × 1.5
	Min/Max:	0.1/(Drive Rated Amps × 1.8)
	Display:	0.1 Amps

### A090 [Motor OL Select]

Related Parameter(s): [P032](#)

Drive provides Class 10 motor overload protection. Settings 0-2 select the derating factor for the  $I^2t$  overload function.

<b>Options</b>	0 “No Derate” (Default)
	1 “Minimum Derate”
	2 “Maximum Derate”

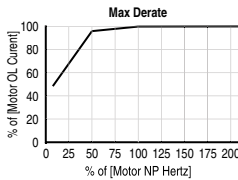
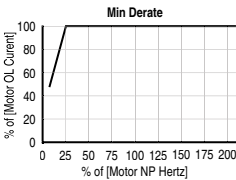
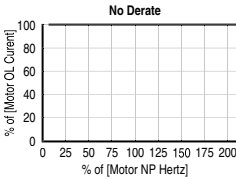

### A091 [PWM Frequency]

Sets the carrier frequency for the PWM output waveform. The chart below provides derating guidelines based on the PWM frequency setting.

**Important:** Ignoring derating guidelines can cause reduced drive performance.

<b>Values</b>	Default	4.0 kHz
	Min/Max:	2.0/16.0 kHz
	Display:	0.1 kHz

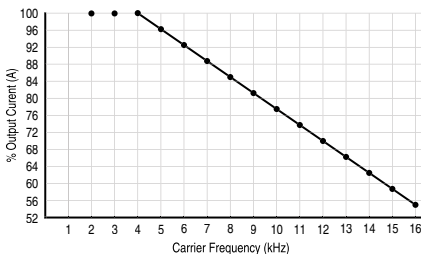

## Advanced Program Group *(continued)*

### A092 [Auto Rstrt Tries]

Sets the maximum number of times the drive attempts to reset a fault and restart.

#### Clear a Type 1 fault and restart the drive.

1. Set A092 [Auto Rstrt Tries] to a value other than "0".
2. Set A093 [[Auto Rstrt Delay](#)] to a value other than "0".

#### Clear an OverVoltage, UnderVoltage or Heatsink OvrTmp fault without restarting the drive.

1. Set A092 [Auto Rstrt Tries] to a value other than "0".
2. Set A093 [[Auto Rstrt Delay](#)] to "0".



**ATTENTION:** Equipment damage and/or personal injury may result if this parameter is used in an inappropriate application. Do not use this function without considering applicable local, national and international codes, standards, regulations or industry guidelines.

<b>Values</b>	Default	0
	Min/Max:	0/9
	Display:	1

### A093 [Auto Rstrt Delay]

Related Parameter(s): [A092](#)

Sets the time between restart attempts when A092 [[Auto Rstrt Tries](#)] is set to a value other than zero.

<b>Values</b>	Default	1.0 Secs
	Min/Max:	0.0/120.0 Secs
	Display:	0.1 Secs



Stop drive before changing this parameter.

### A094 [Start At PowerUp]

Enables/disables a feature that allows a Start or Run command to automatically cause the drive to resume running at commanded speed after drive input power is restored. Requires a digital input configured for Run or Start and a valid start contact.

This parameter will not function if parameter P036 [[Start Source](#)] is set to 4 "2-Wire High Speed".



**ATTENTION:** Equipment damage and/or personal injury may result if this parameter is used in an inappropriate application. Do not use this function without considering applicable local, national and international codes, standards, regulations or industry guidelines.

<b>Options</b>	0	"Disabled" (Default)
	1	"Enabled"

## Advanced Program Group (continued)

 Stop drive before changing this parameter.

---

### A095 [Reverse Disable]

Enables/disables the function that allows the direction of motor rotation to be changed. The reverse command may come from a digital command, the keypad or a serial command. All reverse inputs including two-wire Run Reverse will be ignored with reverse disabled.

---

<b>Options</b>	<b>0</b> "Reverse Enabled" (Default)
	<b>1</b> "Reverse Disabled"

---



---

### A096 [Flying Start En]

Sets the condition that allows the drive to reconnect to a spinning motor at actual RPM.

---

<b>Options</b>	<b>0</b> "Disabled" (Default)
	<b>1</b> "Enabled"

---



---

### A097 [Compensation]

Enables/disables correction options that may improve problems with motor instability.

---

<b>Options</b>	<b>0</b> "Disabled"
	<b>1</b> "Electrical" (Default)
	<b>2</b> "Mechanical"
	<b>3</b> "Both"

---



---

### A098 [SW Current Trip]

Enables/disables a software instantaneous (within 100 ms) current trip.

---

<b>Values</b>	Default	0.0 (Disabled)
	Min/Max:	0.0/(Drive Rated Amps × 2)
	Display:	0.1 Amps

---



---

### A099 [Process Factor]

Related Parameter(s): [d010](#)

Scales the value displayed by d010 [\[Process Display\]](#).

$$\text{Output Freq} \times \text{Process Factor} = \text{Process Display}$$

---

<b>Values</b>	Default	30.0
	Min/Max:	0.1/999.9
	Display:	0.1

---

## Advanced Program Group *(continued)*

 Stop drive before changing this parameter.

### A100 [Fault Clear]

Resets a fault and clears the fault queue.

<b>Options</b>	<b>0</b>	“Ready” (Default)
	<b>1</b>	“Reset Active Fault”
	<b>2</b>	“Clear Fault Queue” (Parameters d007-d009 <a href="#">[Fault x Code]</a> )

### A101 [Program Lock]

Protects parameters against change by unauthorized personnel.

<b>Options</b>	<b>0</b>	“Unlocked” (Default)
	<b>1</b>	“Locked”

### A102 [Testpoint Sel]

Used by Rockwell Automation field service personnel.

<b>Values</b>	Default	400
	Min/Max:	0/FFFF
	Display:	1 Hex

### A103 [Comm Data Rate]

Sets the serial port rate for the RS485 (DSI) port.

**Important:** Power to drive must be cycled before any changes will affect drive operation.

<b>Options</b>	<b>0</b>	“1200”
	<b>1</b>	“2400”
	<b>2</b>	“4800”
	<b>3</b>	“9600” (Default)
	<b>4</b>	“19.2K”
	<b>5</b>	“38.4K”

### A104 [Comm Node Addr]

Sets the drive node address for the RS485 (DSI) port if using a network connection.

**Important:** Power to drive must be cycled before any changes will affect drive operation.

<b>Values</b>	Default	100
	Min/Max:	1/247
	Display:	1

## Advanced Program Group *(continued)*

### A105 [Comm Loss Action]

Related Parameter(s): [P037](#), [A106](#)

Selects the drive's response to a loss of the communication connection or excessive communication errors.

<b>Options</b>	0 "Fault" (Default)	Drive will fault on an F81 Comm Loss and coast to stop.
	1 "Coast to Stop"	Stops drive via coast to stop.
	2 "Stop"	Stops drive via P037 <a href="#">[Stop Mode]</a> setting.
	3 "Continue Last Speed"	Drive continues operating at communication commanded speed saved in RAM.

### A106 [Comm Loss Time]

Related Parameter(s): [A105](#)

Sets the time that the drive will remain in communication loss before implementing the option selected in A105 [\[Comm Loss Action\]](#).

<b>Values</b>	Default	5.0 Secs
	Min/Max:	0.1/60.0 Secs
	Display:	0.1 Secs

### A107 [Comm Format]

Selects the protocol (RTU only), data bits (8 data bits only), parity (None, Even, Odd), and stop bits (1 stop bit only) used by the RS485 port on the drive.

Refer to [Appendix C](#) for details on using the drive communication features.

**Important:** Power to drive must be cycled before any changes will affect drive operation.

<b>Options</b>	0 "RTU 8-N-1" (Default)
	1 "RTU 8-E-1"
	2 "RTU 8-O-1"

### A110 [0-10V Analog Input Low]

Related Parameter(s): [d020](#), [P034](#), [P038](#)

Sets the analog input level that corresponds to P034 [Minimum Freq] if a 0-10V input is used by P038 [Speed Reference].

Analog inversion can be accomplished by setting this value larger than A111 [0-10V Analog Input High].

<b>Values</b>	Default	0.0%
	Min/Max:	0.0/100.0%
	Display:	0.1%

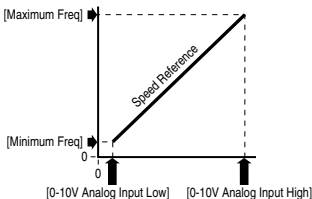

**A111 [0-10V Analog Input High]**Related Parameter(s): [d020](#), [P035](#), [P038](#)

Sets the analog input level that corresponds to P035 [Maximum Freq] if a 0-10V input is used by P038 [Speed Reference].

Analog inversion can be accomplished by setting this value smaller than A110 [0-10V Analog Input Low].

<b>Values</b>	Default	100.0%
	Min/Max:	0.0/100.0%
	Display:	0.1%

**A112 [4-20mA Analog Input Low]**Related Parameter(s): [d021](#), [P034](#), [P038](#)

Sets the analog input level that corresponds to P034 [Minimum Freq] if a 4-20mA input is used by P038 [Speed Reference].

Analog inversion can be accomplished by setting this value larger than A113 [4-20mA Analog Input High].

<b>Values</b>	Default	0.0%
	Min/Max:	0.0/100.0%
	Display:	0.1%

**A113 [4-20mA Analog Input High]**Related Parameter(s): [d021](#), [P035](#), [P038](#)

Sets the analog input level that corresponds to P035 [Maximum Freq] if a 4-20mA input is used by P038 [Speed Reference].

Analog inversion can be accomplished by setting this value smaller than A112 [4-20mA Analog Input Low].

<b>Values</b>	Default	100.0%
	Min/Max:	0.0/100.0%
	Display:	0.1%

**A114 [Slip Compensation]**Related Parameter(s): [P033](#)

Compensates for the inherent slip in an induction motor. This frequency is added to the commanded output frequency based on motor current.

<b>Values</b>	Default	2.0 Hz
	Min/Max:	0.0/10.0 Hz
	Display:	0.1 Hz

## Parameter Cross Reference – by Name

<u>Parameter Name</u>	<u>No.</u>	<u>Group</u>	<u>Parameter Name</u>	<u>No.</u>	<u>Group</u>
0-10V Analog Input	d020	Display	Fault x Code	d007-d009	Display
0-10V Analog Input High	A111	Advanced Program	Fault Clear	A100	Advanced Program
0-10V Analog Input Low	A110	Advanced Program	Flying Start En	A096	Advanced Program
4-20mA Analog Input	d021	Display	Internal Freq	A069	Advanced Program
4-20mA Analog Input High	A113	Advanced Program	Jog Accel/Decel	A079	Advanced Program
4-20mA Analog Input Low	A112	Advanced Program	Jog Frequency	A078	Advanced Program
Accel Time 1	P039	Basic Program	Maximum Freq	P035	Basic Program
Accel Time 2	A067	Advanced Program	Maximum Voltage	A088	Advanced Program
Auto Rstrt Delay	A093	Advanced Program	Minimum Freq	P034	Basic Program
Auto Rstrt Tries	A092	Advanced Program	Motor NP Hertz	P032	Basic Program
Comm Data Rate	A103	Advanced Program	Motor NP Volts	P031	Basic Program
Comm Format	A107	Advanced Program	Motor OL Current	P033	Basic Program
Comm Loss Action	A105	Advanced Program	Motor OL Select	A090	Advanced Program
Comm Loss Time	A106	Advanced Program	Output Current	d003	Display
Comm Node Addr	A104	Advanced Program	Output Freq	d001	Display
Comm Status	d015	Display	Output Voltage	d004	Display
Commanded Freq	d002	Display	Preset Freq x	A070-A073	Advanced Program
Compensation	A097	Advanced Program	Process Display	d010	Display
Contrl In Status	d013	Display	Process Factor	A099	Advanced Program
Control Source	d012	Display	Program Lock	A101	Advanced Program
Control SW Ver	d016	Display	PWM Frequency	A091	Advanced Program
Current Limit	A089	Advanced Program	Relay Out Level	A056	Advanced Program
DB Resistor Sel	A082	Advanced Program	Relay Out Sel	A055	Advanced Program
DC Brake Level	A081	Advanced Program	Reset To Defaults	P041	Basic Program
DC Brake Time	A080	Advanced Program	Reverse Disable	A095	Advanced Program
DC Bus Voltage	d005	Display	S Curve %	A083	Advanced Program
Decel Time 1	P040	Basic Program	Slip Compensation	A114	Advanced Program
Decel Time 2	A068	Advanced Program	Speed Reference	P038	Basic Program
Dig In Status	d014	Display	Start At PowerUp	A094	Advanced Program
Digital Inx Sel	A051, A052	Advanced Program	Start Boost	A084	Advanced Program
Drive Status	d006	Display	Start Source	P036	Basic Program
Drive Type	d017	Display	Stop Mode	P037	Basic Program
Elapsed Run Time	d018	Display	SW Current Trip	A098	Advanced Program
			Testpoint Data	d019	Display
			Testpoint Sel	A102	Advanced Program

## Troubleshooting

Chapter 4 provides information to guide you in troubleshooting the PowerFlex 4 drive. Included is a listing and description of drive faults (with possible solutions, when applicable).

For information on...	See page...	For information on...	See page...
<a href="#">Drive Status</a>	<a href="#">4-1</a>	<a href="#">Fault Descriptions</a>	<a href="#">4-3</a>
<a href="#">Faults</a>	<a href="#">4-1</a>	<a href="#">Common Symptoms and Corrective Actions</a>	<a href="#">4-5</a>

### Drive Status

The condition or state of your drive is constantly monitored. Any changes will be indicated through the integral keypad.

### LED Indications

See [page 2-3](#) for information on drive status indicators and controls.

### Faults

A fault is a condition that stops the drive. There are two fault types.

Type	Fault Description
①	Auto-Reset/Run When this type of fault occurs, and A092 <a href="#">[Auto Rstrt Tries]</a> is set to a value greater than "0," a user-configurable timer, A093 <a href="#">[Auto Rstrt Delay]</a> , begins. When the timer reaches zero, the drive attempts to automatically reset the fault. If the condition that caused the fault is no longer present, the fault will be reset and the drive will be restarted.
②	Non-Resetable This type of fault may require drive or motor repair, or is caused by wiring or programing errors. The cause of the fault must be corrected before the fault can be cleared.

## Fault Indication

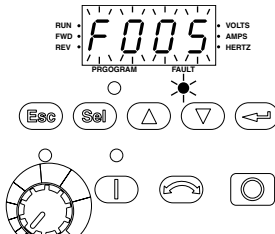
Condition	Display
<p><b>Drive is indicating a fault.</b></p> <p>The integral keypad provides visual notification of a fault condition by displaying the following.</p> <ul style="list-style-type: none"> <li>Flashing fault number</li> <li>Flashing fault indicator</li> </ul> <p>Press the Escape key to regain control of the integral keypad.</p>	 <p>The diagram shows a control panel with a digital display showing 'F005'. Above the display are indicators for RUN, FWD, REV, PROGRAM, and FAULT. To the right are indicators for VOLTS, AMPS, and HERTZ. Below the display is a flashing fault indicator. The keypad includes buttons for Esc, Sel, and various navigation keys (up, down, left, right, stop, and a circular button).</p>

## Manually Clearing Faults

Step	Key(s)
<ol style="list-style-type: none"> <li>Press Esc to acknowledge the fault. The fault information will be removed so that you can use the integral keypad. Access d007 <a href="#">[Fault 1 Code]</a> to view the most recent fault information.</li> <li>Address the condition that caused the fault. The cause must be corrected before the fault can be cleared. See <a href="#">Table 4.A</a>.</li> <li>After corrective action has been taken, clear the fault by one of these methods. <ul style="list-style-type: none"> <li>Press Stop if P037 <a href="#">[Stop Mode]</a> is set to a value between "0" and "3".</li> <li>Cycle drive power.</li> <li>Set A100 <a href="#">[Fault Clear]</a> to "1" or "2".</li> <li>Cycle digital input if A051 - A052 <a href="#">[Digital Inx Sel]</a> is set to option 7 "Clear Fault".</li> </ul> </li> </ol>	 <p>The diagram shows two keys: the Esc key and the Stop Mode key (a square button with a circle and a vertical line).</p>

## Automatically Clearing Faults

Option / Step
<p><b>Clear a Type 1 fault and restart the drive.</b></p>
<ol style="list-style-type: none"> <li>Set A092 <a href="#">[Auto Rstrt Tries]</a> to a value other than "0".</li> <li>Set A093 <a href="#">[Auto Rstrt Delay]</a> to a value other than "0".</li> </ol>
<p><b>Clear an OverVoltage, UnderVoltage or Heatsink OvrTmp fault without restarting the drive.</b></p>
<ol style="list-style-type: none"> <li>Set A092 <a href="#">[Auto Rstrt Tries]</a> to a value other than "0".</li> <li>Set A093 <a href="#">[Auto Rstrt Delay]</a> to "0".</li> </ol>

## Auto Restart (Reset/Run)

The Auto Restart feature provides the ability for the drive to automatically perform a fault reset followed by a start attempt without user or application intervention. This allows remote or "unattended" operation. Only certain faults are allowed to be reset. Certain faults (Type 2) that indicate possible drive component malfunction are not resettable.

Caution should be used when enabling this feature, since the drive will attempt to issue its own start command based on user selected programming.

## Fault Descriptions

Table 4.A Fault Types, Descriptions and Actions

No.	Fault	Type <sup>(1)</sup>	Description	Action
F2	Auxiliary Input	①	Auxiliary input interlock is open.	<ol style="list-style-type: none"> <li>1. Check remote wiring.</li> <li>2. Verify communications programming for intentional fault.</li> </ol>
F3	Power Loss	②	DC bus voltage remained below 85% of nominal.	<ol style="list-style-type: none"> <li>1. Monitor the incoming AC line for low voltage or line power interruption.</li> <li>2. Check input fuses.</li> </ol>
F4	UnderVoltage	①	DC bus voltage fell below the minimum value.	Monitor the incoming AC line for low voltage or line power interruption.
F5	OverVoltage	①	DC bus voltage exceeded maximum value.	Monitor the AC line for high line voltage or transient conditions. Bus overvoltage can also be caused by motor regeneration. Extend the decel time or install dynamic brake option.
F6	Motor Stalled	①	Drive is unable to accelerate motor.	Increase <a href="#">P039 - A067</a> [Accel Time x] or reduce load so drive output current does not exceed the current set by parameter A089 [ <a href="#">Current Limit</a> ].
F7	Motor Overload	①	Internal electronic overload trip.	<ol style="list-style-type: none"> <li>1. An excessive motor load exists. Reduce load so drive output current does not exceed the current set by parameter P033 [<a href="#">Motor OL Current</a>].</li> <li>2. Verify A084 [<a href="#">Start Boost</a>] setting</li> </ol>
F8	Heatsink OvrTmp	①	Heatsink temperature exceeds a predefined value.	<ol style="list-style-type: none"> <li>1. Check for blocked or dirty heat sink fins. Verify that ambient temperature has not exceeded 40°C (104°F) for IP 30/NEMA 1/UL Type 1 installations or 50°C (122°F) for IP20/Open type installations.</li> <li>2. Check fan.</li> </ol>
F12	HW OverCurrent	②	The drive output current has exceeded the hardware current limit.	Check programming. Check for excess load, improper A084 [ <a href="#">Start Boost</a> ] setting, DC brake volts set too high or other causes of excess current.
F13	Ground Fault	②	A current path to earth ground has been detected at one or more of the drive output terminals.	Check the motor and external wiring to the drive output terminals for a grounded condition.

<sup>(1)</sup> See [page 4-1](#) for a description of fault types.

No.	Fault	Type <sup>(1)</sup>	Description	Action
F33	Auto Rstrt Tries	②	Drive unsuccessfully attempted to reset a fault and resume running for the programmed number of A092 [ <a href="#">Auto Rstrt Tries</a> ].	Correct the cause of the fault and manually clear.
F38	Phase U to Gnd	②	A phase to ground fault has been detected between the drive and motor in this phase.	<ol style="list-style-type: none"> <li>1. Check the wiring between the drive and motor.</li> <li>2. Check motor for grounded phase.</li> <li>3. Replace drive if fault cannot be cleared.</li> </ol>
F39	Phase V to Gnd			
F40	Phase W to Gnd			
F41	Phase UV Short	②	Excessive current has been detected between these two output terminals.	<ol style="list-style-type: none"> <li>1. Check the motor and drive output terminal wiring for a shorted condition.</li> <li>2. Replace drive if fault cannot be cleared.</li> </ol>
F42	Phase UW Short			
F43	Phase VW Short			
F48	Params Defaulted		The drive was commanded to write default values to EEPROM.	<ol style="list-style-type: none"> <li>1. Clear the fault or cycle power to the drive.</li> <li>2. Program the drive parameters as needed.</li> </ol>
F63	SW OverCurrent	①	Programmed A098 [ <a href="#">SW Current Trip</a> ] has been exceeded.	Check load requirements and A098 [ <a href="#">SW Current Trip</a> ] setting.
F64	Drive Overload	②	Drive rating of 150% for 1 minute or 200% for 3 seconds has been exceeded.	Reduce load or extend Accel Time.
F70	Power Unit	②	Failure has been detected in the drive power section.	<ol style="list-style-type: none"> <li>1. Cycle power.</li> <li>2. Replace drive if fault cannot be cleared.</li> </ol>
F81	Comm Loss	②	RS485 (DSI) port stopped communicating.	<ol style="list-style-type: none"> <li>1. If adapter was not intentionally disconnected, check wiring to the port. Replace wiring, port expander, adapters or complete drive as required.</li> <li>2. Check connection.</li> <li>3. An adapter was intentionally disconnected.</li> <li>4. Turn off using A105 [<a href="#">Comm Loss Action</a>].</li> </ol>
F100	Parameter Checksum	②	The checksum read from the board does not match the checksum calculated.	Set P041 [ <a href="#">Reset To Defaults</a> ] to option 1 "Reset Defaults".
F122	I/O Board Fail	②	Failure has been detected in the drive control and I/O section.	<ol style="list-style-type: none"> <li>1. Cycle power.</li> <li>2. Replace drive if fault cannot be cleared.</li> </ol>

<sup>(1)</sup> See [page 4-1](#) for a description of fault types.

## Common Symptoms and Corrective Actions

### Motor does not Start.

Cause(s)	Indication	Corrective Action
No output voltage to the motor.	None	<p>Check the power circuit.</p> <ul style="list-style-type: none"> <li>• Check the supply voltage.</li> <li>• Check all fuses and disconnects.</li> </ul> <p>Check the motor.</p> <ul style="list-style-type: none"> <li>• Verify that the motor is connected properly.</li> </ul> <p>Check the control input signals.</p> <ul style="list-style-type: none"> <li>• Verify that a Start signal is present. If 2-Wire control is used, verify that either the Run Forward or Run Reverse signal is active, but not both.</li> <li>• Verify that I/O Terminal 01 is active.</li> <li>• Verify that P036 <a href="#">[Start Source]</a> matches your configuration.</li> <li>• Verify that A095 <a href="#">[Reverse Disable]</a> is not prohibiting movement.</li> </ul>

### Drive does not Start from Start or Run Inputs wired to the terminal block.

Cause(s)	Indication	Corrective Action
Drive is Faulted	Flashing red status light	<p>Clear fault.</p> <ul style="list-style-type: none"> <li>• Press Stop</li> <li>• Cycle power</li> <li>• Set A100 <a href="#">[Fault Clear]</a> to option 1 "Clear Faults".</li> <li>• Cycle digital input if A051 - A052 <a href="#">[Digital Inx Sel]</a> is set to option 7 "Clear Fault".</li> </ul>
<p>Incorrect programming.</p> <ul style="list-style-type: none"> <li>• P036 <a href="#">[Start Source]</a> is set to option 0 "Keypad" or option 5 "RS485 (DSI) Port".</li> <li>• A051 - A052 <a href="#">[Digital Inx Sel]</a> is set to option 5 "Local" and the input is active.</li> </ul>	None	Check parameter settings.
<p>Incorrect input wiring. See <a href="#">1-14</a> for wiring examples.</p> <ul style="list-style-type: none"> <li>• 2 wire control requires Run Forward, Run Reverse or Jog input.</li> <li>• 3 wire control requires Start and Stop inputs</li> <li>• Stop input is always required.</li> </ul>	None	Wire inputs correctly and/or install jumper.
Incorrect Sink/Source DIP switch setting.	None	Set switch to match wiring scheme.

**Drive does not Start from Integral Keypad.**

Cause(s)	Indication	Corrective Action
Integral keypad is not enabled.	Green LED above Start key is not illuminated.	<ul style="list-style-type: none"> <li>Set parameter P036 [<a href="#">Start Source</a>] to option 0 “Keypad”.</li> <li>Set parameter A051 - A052 [<a href="#">Digital Inx Sel</a>] to option 5 “Local” and activate the input.</li> </ul>
I/O Terminal 01 “Stop” input is not present.	None	Wire inputs correctly and/or install jumper.

**Drive does not respond to changes in speed command.**

Cause(s)	Indication	Corrective Action
No value is coming from the source of the command.	The drive “Run” indicator is lit and output is 0 Hz.	<ul style="list-style-type: none"> <li>Check d012 [<a href="#">Control Source</a>] for correct source.</li> <li>If the source is an analog input, check wiring and use a meter to check for presence of signal.</li> <li>Check d002 [<a href="#">Commanded Freq</a>] to verify correct command.</li> </ul>
Incorrect reference source is being selected via remote device or digital inputs.	None	<ul style="list-style-type: none"> <li>Check d012 [<a href="#">Control Source</a>] for correct source.</li> <li>Check d014 [<a href="#">Dig In Status</a>] to see if inputs are selecting an alternate source. Verify settings for A051 - A052 [<a href="#">Digital Inx Sel</a>].</li> <li>Check P038 [<a href="#">Speed Reference</a>] for the source of the speed reference. Reprogram as necessary.</li> <li>Review the Speed Reference Control chart on <a href="#">page 1-17</a>.</li> </ul>

**Motor and/or drive will not accelerate to commanded speed.**

Cause(s)	Indication	Corrective Action
Acceleration time is excessive.	None	Reprogram P039 [ <a href="#">Accel Time 1</a> ] or A067 [ <a href="#">Accel Time 2</a> ].
Excess load or short acceleration times force the drive into current limit, slowing or stopping acceleration.	None	<p>Compare d003 [<a href="#">Output Current</a>] with A089 [<a href="#">Current Limit</a>].</p> <p>Remove excess load or reprogram P039 [<a href="#">Accel Time 1</a>] or A067 [<a href="#">Accel Time 2</a>].</p> <p>Check for improper A084 [<a href="#">Start Boost</a>] setting.</p>
Speed command source or value is not as expected.	None	Verify d002 [ <a href="#">Commanded Freq</a> ]. Check d012 [ <a href="#">Control Source</a> ] for the proper Speed Command.
Programming is preventing the drive output from exceeding limiting values.	None	Check P035 [ <a href="#">Maximum Freq</a> ] to insure that speed is not limited by programming.

**Motor operation is unstable.**

Cause(s)	Indication	Corrective Action
Motor data was incorrectly entered.	None	<ol style="list-style-type: none"> <li>1. Correctly enter motor nameplate data into <a href="#">P031</a>, <a href="#">P032</a> and <a href="#">P033</a>.</li> <li>2. Enable A097 <a href="#">[Compensation]</a>.</li> <li>3. Use A084 <a href="#">[Start Boost]</a> to reduce boost level.</li> </ol>

**Drive will not reverse motor direction.**

Cause(s)	Indication	Corrective Action
Digital input is not selected for reversing control.	None	Check [Digital Inx Sel] ( <a href="#">See page 3-13</a> ). Choose correct input and program for reversing mode.
Digital input is incorrectly wired.	None	Check input wiring. ( <a href="#">See page 1-13</a> )
Motor wiring is improperly phased for reverse.	None	Switch two motor leads.
Reverse is disabled.	None	Check A095 <a href="#">[Reverse Disable]</a> .

**Notes:**

## Supplemental Drive Information

For information on...	See page...
<a href="#">Drive, Fuse &amp; Circuit Breaker Ratings</a>	<a href="#">A-1</a>
<a href="#">Specifications</a>	<a href="#">A-2</a>

### Drive, Fuse & Circuit Breaker Ratings

The tables on the following pages provide drive ratings and recommended AC line input fuse and circuit breaker information. Both types of short circuit protection are acceptable for UL and IEC requirements. Sizes listed are the recommended sizes based on 40 degree C and the U.S. N.E.C. Other country, state or local codes may require different ratings.

#### Fusing

**If fuses are chosen as the desired protection method**, refer to the recommended types listed below. If available amp ratings do not match the tables provided, the closest fuse rating that exceeds the drive rating should be chosen.

- IEC – BS88 (British Standard) Parts 1 & 2<sup>(1)</sup>, EN60269-1, Parts 1 & 2, type gG or equivalent should be used.
- UL – UL Class CC, T or J must be used.<sup>(2)</sup>

#### Circuit Breakers

Refer to listings in the following tables for recommended circuit breakers (inverse time or instantaneous trip) and 140M Self-Protecting Motor Starters.

<sup>(1)</sup> Typical designations include, but may not be limited to the following; Parts 1 & 2: AC, AD, BC, BD, CD, DD, ED, EFS, EF, FF, FG, GF, GG, GH.

<sup>(2)</sup> Typical designations include; Type CC - KTK-R, FNQ-R  
Type J - JKS, LPJ  
Type T - JJS, JJN

## Specifications

Drive Ratings									
Catalog Number	Output Ratings		Input Ratings			Branch Circuit Protection			Power Dissipation
	kW (HP)	Amps	Voltage Range	kVA	Amps	Fuses	140M Motor Protectors	Contactors	IP20 Open Watts
<b>100 - 115V AC 1-Phase Input, 0 - 230V 3-Phase Output</b>									
22A-V1P5N104	0.2 (0.25)	1.5	90-126	0.75	6.0	10	140M-C2E-C10	100-C09	25
22A-V2P3N104	0.37 (0.5)	2.3	90-126	1.15	9.0	15	140M-C2E-C16	100-C12	30
22A-V4P5N104	0.75 (1.0)	4.5	90-126	2.25	18.0	30	140M-D8E-C20	100-C23	50
<b>200 - 240V AC – 1-Phase<sup>(1)</sup> Input, 0 - 230V 3-Phase Output</b>									
22A-A1P5N104	0.2 (0.25)	1.5	180-265	0.75	5.0	10	140M-C2E-B63	100-C09	25
22A-A2P3N104	0.37 (0.5)	2.3	180-265	1.15	6.0	10	140M-C2E-B63	100-C09	30
22A-A4P5N104	0.75 (1.0)	4.5	180-265	2.25	10.0	15	140M-C2E-C16	100-C12	50
22A-A8P0N104	1.5 (2.0)	8.0	180-265	4.0	18.0	30	140M-D8E-C20	100-C23	80
<b>200 - 240V AC – 3-Phase Input, 0 - 230V 3-Phase Output</b>									
22A-B1P5N104	0.2 (0.25)	1.5	180-265	0.75	1.8	3	140M-C2E-B25	100-C09	25
22A-B2P3N104	0.37 (0.5)	2.3	180-265	1.15	2.5	6	140M-C2E-B40	100-C09	30
22A-B4P5N104	0.75 (1.0)	4.5	180-265	2.25	5.2	10	140M-C2E-C10	100-C09	50
22A-B8P0N104	1.5 (2.0)	8.0	180-265	4.0	9.5	15	140M-C2E-C16	100-C12	80
22A-B012N104	2.2 (3.0)	12.0	180-265	5.5	15.5	25	140M-C2E-C16	100-C16	115
22A-B017N104	3.7 (5.0)	17.5	180-265	8.6	21.0	35	140M-F8E-C25	100-C23	165
<b>380 - 480V AC – 3-Phase Input, 0 - 460V 3-Phase Output</b>									
22A-D1P4N104	0.37 (0.5)	1.4	340-528	1.4	1.8	3	140M-C2E-B25	100-C09	30
22A-D2P3N104	0.75 (1.0)	2.3	340-528	2.3	3.2	6	140M-C2E-B40	100-C09	40
22A-D4P0N104	1.5 (2.0)	4.0	340-528	4.0	5.7	10	140M-C2E-B63	100-C09	60
22A-D6P0N104	2.2 (3.0)	6.0	340-528	5.9	7.5	15	140M-C2E-C10	100-C09	90
22A-D8P7N104	3.7 (5.0)	8.7	340-528	8.6	9.0	15	140M-C2E-C16	100-C16	145
<b>Input/Output Ratings</b>					<b>Approvals</b>				
Output Frequency: 0-240 Hz (Programmable)									
Efficiency: 97.5% (Typical)									
<b>Digital Control Inputs (Input Current = 6mA)</b>					<b>Analog Control Inputs</b>				
SRC (Source) Mode: 18-24V = ON 0-6V = OFF		SNK (Sink) Mode: 0-6V = ON 18-24V = OFF			4-20mA Analog: 250 ohm input impedance 0-10V DC Analog: 100k ohm input impedance External Pot: 1-10k ohms, 2 Watt minimum				
<b>Control Output</b>									
Programmable Output (form C relay)									
Resistive Rating: 3.0A at 30V DC, 3.0A at 125V AC, 3.0A at 240V AC									
Inductive Rating: 0.5A at 30V DC, 0.5A at 125V AC, 0.5A at 240V AC									
<b>Fuses and Circuit Breakers</b>									
Recommended Fuse Type: UL Class J, CC, T or Type BS88; 600V (550V) or equivalent.									
Other Protective Devices: 140M-xxx (A-B Bulletin 140 Manual Motor Starter) or HMCP circuit breaker or equivalent.									
<b>Protective Features</b>									
Motor Protection: <sup>2</sup> overload protection - 150% for 60 Secs, 200% for 3 Secs (Provides Class 10 protection)									
Overcurrent: 200% hardware limit, 300% instantaneous fault									
<b>Over Voltage:</b> 100-120V AC Input – Trip occurs at 405V DC bus voltage (equivalent to 150V AC incoming line) 200-240V AC Input – Trip occurs at 405V DC bus voltage (equivalent to 290V AC incoming line) 380-480V AC Input – Trip occurs at 810V DC bus voltage (equivalent to 575V AC incoming line)									
<b>Under Voltage:</b> 100-120V AC Input – Trip occurs at 210V DC bus voltage (equivalent to 75V AC incoming line) 200-240V AC Input – Trip occurs at 210V DC bus voltage (equivalent to 150V AC incoming line) 380-480V AC Input – Trip occurs at 390V DC bus voltage (equivalent to 275V AC incoming line)									
Control Ride Through: Minimum ride through is 0.5 Secs - typical value 2 Secs									
Faultless Power Ride Through: 100 milliseconds									
<b>Dynamic Braking</b>									
Internal brake IGBT included with all ratings 0.75 kW (1 HP) and larger. Refer to <a href="#">page B-2</a> for external dynamic brake module options.									

(1) 200-240V AC - 1-Phase drives are also available with an integral EMC filter. Catalog suffix changes from N104 to N114.

Category	Specification	
Environment	Altitude:	1000 m (3300 ft) max. without derating
	Ambient Operating Temperature	
	IP20:	-10 to 50 degrees C (14 to 122 degrees F)
	NEMA 1:	-10 to 40 degrees C (14 to 104 degrees F)
	Cooling Method	
	Convection:	0.2 kW (0.25 HP) drive ratings, Catalog Numbers 22A-V1P5N104, 22A-A1P5N114, 22A-A1P5104 and 22A-B1P5N104
	Fan:	All other drive ratings.
	Storage Temperature:	-40 to 85 degrees C (-40 to 185 degrees F)
	Atmosphere:	<b>Important:</b> Drive <b>must not</b> be installed in an area where the ambient atmosphere contains volatile or corrosive gas, vapors or dust. If the drive is not going to be installed for a period of time, it must be stored in an area where it will not be exposed to a corrosive atmosphere.
	Relative Humidity:	0 to 95% non-condensing
Shock (operating):	15G peak for 11ms duration ( $\pm 1.0$ ms)	
Vibration (operating):	1G peak, 5 to 2000 Hz	
Control	Carrier Frequency	2-16 kHz. Drive rating based on 4 kHz.
	Frequency Accuracy	
	Digital Input:	Within $\pm 0.05\%$ of set output frequency.
	Analog Input:	Within 0.5% of maximum output frequency.
	Speed Regulation - Open Loop with Slip Compensation:	$\pm 2\%$ of base speed across a 40:1 speed range.
	Stop Modes:	Multiple programmable stop modes including - Ramp, Coast, DC-Brake, Ramp-to-Hold and S Curve.
	Accel/Decel:	Two independently programmable accel and decel times. Each time may be programmed from 0 - 600 seconds in 0.1 second increments.
	Intermittent Overload:	150% Overload capability for up to 1 minute 200% Overload capability for up to 3 seconds
Electronic Motor Overload Protection	Class 10 protection with speed sensitive response.	

**Notes:**

## Accessories and Dimensions

For information on...	See page
<a href="#">Product Selection</a>	B-1
<a href="#">Product Dimensions</a>	B-5

### Product Selection

Table B.A Catalog Number Description

<b>22A</b>	<b>-</b>	<b>A</b>	<b>1P5</b>	<b>N</b>	<b>1</b>	<b>1</b>	<b>4</b>
Drive		Voltage Rating	Rating	Enclosure	HIM	Emission Class	Comm Slot

Table B.B PowerFlex 4 Drives

Drive Ratings					
Input Voltage	kW	HP	Output Current	Catalog Number	Frame Size
120V 50/60 Hz 1-Phase No Filter	0.2	0.25	1.5A	22A-V1P5N104	A
	0.37	0.5	2.3A	22A-V2P3N104	A
	0.75	1.0	4.5A	22A-V4P5N104	B
240V 50/60 Hz 1-Phase With Integral "S Type" EMC Filter	0.2	0.25	1.5A	22A-A1P5N114	A
	0.37	0.5	2.3A	22A-A2P3N114	A
	0.75	1.0	4.5A	22A-A4P5N114	A
	1.5	2.0	8.0A	22A-A8P0N114	B
240V 50/60 Hz 1-Phase No Filter	0.2	0.25	1.5A	22A-A1P5N104	A
	0.37	0.5	2.3A	22A-A2P3N104	A
	0.75	1.0	4.5A	22A-A4P5N104	A
	1.5	2.0	8.0A	22A-A8P0N104	B
240V 50/60 Hz 3-Phase No Filter	0.2	0.25	1.5A	22A-B1P5N104	A
	0.37	0.5	2.3A	22A-B2P3N104	A
	0.75	1.0	4.5A	22A-B4P5N104	A
	1.5	2.0	8.0A	22A-B8P0N104	A
	2.2	3.0	12.0A	22A-B012N104	B
	3.7	5.0	17.5	22A-B017N104	B
480V 50/60 Hz 3-Phase No Filter	0.37	0.5	1.4A	22A-D1P4N104	A
	0.75	1.0	2.3A	22A-D2P3N104	A
	1.5	2.0	4.0A	22A-D4P0N104	A
	2.2	3.0	6.0A	22A-D6P0N104	B
	3.7	5.0	8.7A	22A-D8P7N104	B

**Table B.C Dynamic Brake Modules**

Drive Ratings			
Input Voltage	kW	HP	Catalog Number
120V 50/60 Hz 1-Phase	0.2	0.25	(1)
	0.37	0.5	(1)
	0.75	1.0	160-BMA1
240V 50/60 Hz 1-Phase	0.2	0.25	(1)
	0.37	0.5	(1)
	0.75	1.0	160-BMA1
	1.5	2.0	160-BMA2
240V 50/60 Hz 3-Phase	0.2	0.25	(1)
	0.37	0.5	(1)
	0.75	1.0	160-BMA1
	1.5	2.0	160-BMA2
	2.2	3.0	160-BMA2
	3.7	5.0	160-BMA2 (2)
480V 50/60 Hz 3-Phase	0.37	0.5	(1)
	0.75	1.0	160-BMB1
	1.5	2.0	160-BMB2
	2.2	3.0	160-BMB2
	3.7	5.0	160-BMB2 (2)

(1) Drive does not support dynamic braking.

(2) Two in parallel required.

**Table B.D Bulletin 1321-3R Series Line Reactors**

Input Voltage	kW	HP	Fundamental Amps	Maximum Continuous Amps	Inductance	Watts Loss	Catalog Number (1)
240V 50/60 Hz 3-Phase	0.2	0.25	2	3	12.0 mh	7.5 W	1321-3R2-A
	0.37	0.5	4	6	12.0 mh	21 W	1321-3R4-D
	0.75	1.0	4	6	3.0 mh	14.5 W	1321-3R4-A
	1.5	2.0	8	12	1.5 mh	19.5 W	1321-3R8-A
	2.2	3.0	12	18	1.25 mh	26 W	1321-3R12-A
	3.7	5.0	18	27	0.8 mh	36 W	1321-3R18-A
480V 50/60 Hz 3-Phase	0.37	0.5	2	3	20.0 mh	11.3 W	1321-3R2-B
	0.75	1.0	2	3	12.0 mh	7.5 W	1321-3R2-A
	1.5	2.0	4	6	6.5 mh	20 W	1321-3R4-B
	2.2	3.0	8	12	12.0 mh	25.3 W	1321-3R8-C
	3.7	5.0	18	27	3.0 mh	29 W	1321-3R8-B

(1) Catalog numbers listed are for 3% impedance open style units. NEMA Type 1 and 5% impedance reactor types are also available. Refer to publication 1321-TD001x.

Table B.E EMC Line Filters

Drive Ratings			S Type Filter Catalog Number <sup>(1)</sup>	L Type Filter Catalog Number <sup>(3)</sup>
Input Voltage	kW	HP		
120V 50/60 Hz 1-Phase	0.2	0.25	–	22-RF010-AL
	0.37	0.5	–	22-RF010-AL
	0.75	1.0	–	22-RF018-BL
240V 50/60 Hz 1-Phase	0.2	0.25	<sup>(2)</sup>	22-RF010-AL
	0.37	0.5	<sup>(2)</sup>	22-RF010-AL
	0.75	1.0	<sup>(2)</sup>	22-RF010-AL
	1.5	2.0	<sup>(2)</sup>	22-RF018-BL
240V 50/60 Hz 3-Phase	0.2	0.25	22-RF9P5-AS	22-RF9P5-AL
	0.37	0.5	22-RF9P5-AS	22-RF9P5-AL
	0.75	1.0	22-RF9P5-AS	22-RF9P5-AL
	1.5	2.0	22-RF9P5-AS	22-RF9P5-AL
	2.2	3.0	22-RF021-BS	22-RF021-BL
	3.7	5.0	22-RF021-BS	22-RF021-BL
480V 50/60 Hz 3-Phase	0.37	0.5	22-RF5P7-AS	22-RF5P7-AL
	0.75	1.0	22-RF5P7-AS	22-RF5P7-AL
	1.5	2.0	22-RF5P7-AS	22-RF5P7-AL
	2.2	3.0	22-RF012-BS	22-RF012-BL
	3.7	5.0	22-RF012-BS	22-RF012-BL

- <sup>(1)</sup> This filter is suitable for use with a cable length of at least 10 meters (33 feet) for Class A and 1 meter for Class B environments.
- <sup>(2)</sup> These ratings can be ordered with internal “S Type” filters. Refer to the Catalog Number explanation on [page P-4](#) and [Table B.B](#) for details.
- <sup>(3)</sup> This filter is suitable for use with a cable length of at least 100 meters for Class A and 5 meters for Class B environments.

**Table B.F Communication Option Kits**

Item	Description	Catalog Number <sup>(2)</sup>
Serial Converter Module (RS485 to RS232)	Provides serial communication via DF1 protocol for use with DriveExplorer and DriveExecutive software. Includes: DSI to RS232 serial converter (1) 1203-SFC serial cable (1) 22-RJ45CBL-C20 cable (1) DriveExplorer Lite CD (1)	22-SCM-232
DSI Cable	2.0 meter RJ45 to RJ45 cable, male to male connectors.	22-RJ45CBL-C20
Serial Cable	2.0 meter serial cable with a locking low profile connector to connect to the serial converter and a 9-pin sub-miniature D female connector to connect to a computer.	1203-SFC
Null Cable Converter	For use when connecting the serial converter to DriveExplorer on a handheld PC.	1203-SNM
DriveExplorer Software (CD-ROM) Version 3.01 or later	Windows based software package that provides an intuitive means for monitoring or configuring Allen-Bradley drives and communication adapters online. Compatibility: Windows 95, 98, ME, NT 4.0 (Service Pack 3 or later), 2000, XP and CE <sup>(1)</sup>	9306-4EXP01ENE
DriveExecutive software (CD-ROM) Version 1.01 or later	Windows based software package that provides an intuitive means for monitoring or configuring Allen-Bradley drives and communication adapters online and offline. Compatibility: Windows 98, ME, NT 4.0 (Service Pack 3 or later), 2000 and XP	9303-4DTE01ENE

<sup>(1)</sup> See [www.ab.com/drives/driveexplorer.htm](http://www.ab.com/drives/driveexplorer.htm) for supported devices.

<sup>(2)</sup> For pricing information, refer to the PowerFlex 4 Price List, Publication 22A-PL001A-EN-P.

**Table B.G IP30/NEMA 1/UL Type 1 Kit**

Item	Description	Drive Frame	Catalog Number <sup>(1)</sup>
		A	22-JBAA
IP30/NEMA 1/UL Type 1 Kit	Field installed kit. Converts drive to IP30/NEMA 1/UL Type 1 enclosure. Includes conduit box with mounting screws and plastic top panel.	B	22-JBAB

<sup>(1)</sup> For pricing information, refer to the PowerFlex 4 Price List, Publication 22A-PL001A-EN-P.

## Product Dimensions

**Figure B.1 PowerFlex 4 Drives –** Dimensions are in millimeters and (inches). Weights are in kilograms and (pounds).

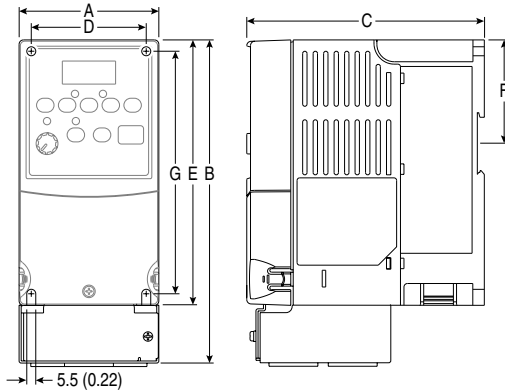

Frame	A	B <sup>(1)</sup>	C	D	E <sup>(2)</sup>	F	G	Shipping Weight
A	80 (3.15)	185 (7.28)	136 (5.35)	67 (2.64)	152 (5.98)	59.3 (2.33)	140 (5.51)	1.4 (3.1)
B	100 (3.94)	213 (8.39)	136 (5.35)	87 (3.43)	180 (7.09)	87.4 (3.44)	168 (6.61)	2.2 (4.9)

<sup>(1)</sup> Overall height of drive with IP 30/NEMA 1/UL Type 1 option kit installed.

<sup>(2)</sup> Overall height of standard IP 20/Open Type drive.

**Table B.H PowerFlex 4 Frames –** Ratings are in kW and (HP)

Frame	120V AC – 1-Phase	240V AC – 1-Phase	240V AC – 3-Phase	480V AC – 3-Phase
A	0.2 (0.25) 0.37 (0.5)	0.2 (0.25) 0.37 (0.5) 0.75 (1.0)	0.2 (0.25) 0.37 (0.5) 0.75 (1.0) 1.5 (2.0)	0.37 (0.5) 0.75 (1.0) 1.5 (2.0)
B	0.75 (1.0)	1.5 (2.0)	2.2 (3.0) 3.7 (5.0)	2.2 (3.0) 3.7 (5.0)

**Figure B.2 Optional Conduit Box –** Dimensions are in millimeters and (inches)

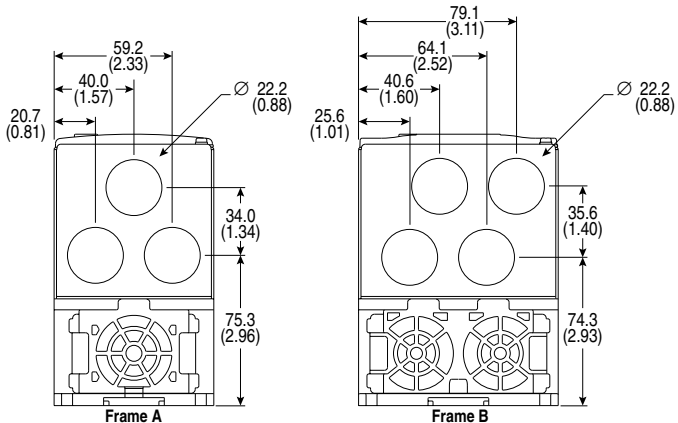

**Figure B.3 Dynamic Brake Modules** – Dimensions are in millimeters and (inches)

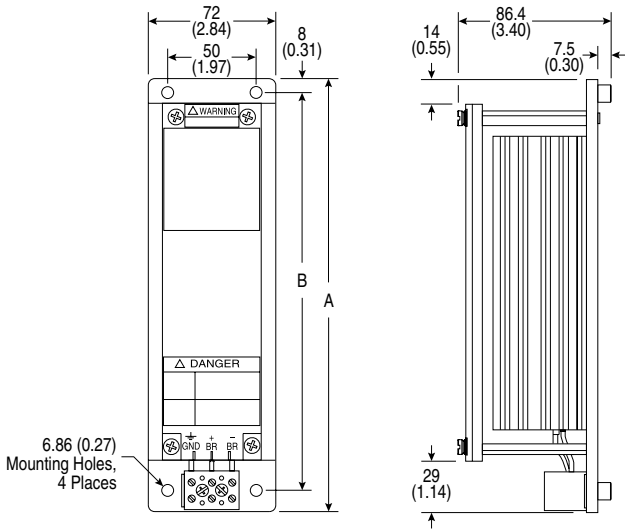

Catalog Number	A	B
160-BMA1, -BMB1	245 (9.64)	225 (8.86)
160-BMA2, -BMB2	334 (13.15)	314 (12.36)

**Figure B.4 Bulletin 1321-3R Series Line Reactors**

– Dimensions are in millimeters and (inches). Weights are in kilograms and (pounds).

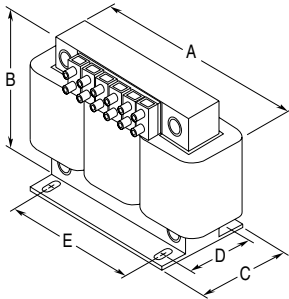

Catalog Number	A	B	C	D	E	Weight
1321-3R2-A	112 (4.40)	104 (4.10)	70 (2.75)	50 (1.98)	37 (1.44)	1.8 (4)
1321-3R2-B	112 (4.40)	104 (4.10)	70 (2.75)	50 (1.98)	37 (1.44)	1.8 (4)
1321-3R4-A	112 (4.40)	104 (4.10)	76 (3.00)	50 (1.98)	37 (1.44)	1.8 (4)
1321-3R4-B	112 (4.40)	104 (4.10)	76 (3.00)	50 (1.98)	37 (1.44)	1.8 (4)
1321-3R8-A	152 (6.00)	127 (5.00)	76 (3.00)	53 (2.10)	51 (2.00)	3.1 (7)
1321-3R8-B	152 (6.00)	127 (5.00)	76 (3.00)	53 (2.10)	51 (2.00)	3.6 (8)
1321-3R12-A	152 (6.00)	127 (5.00)	76 (3.00)	53 (2.10)	51 (2.00)	4.1 (9)
1321-3R18-A	152 (6.00)	133 (5.25)	79 (3.10)	54 (2.13)	51 (2.00)	4.1 (9)
1321-3R18-B	152 (6.00)	133 (5.25)	86 (3.40)	63 (2.48)	51 (2.00)	5.4 (12)

**Figure B.5 Frame A EMC Line Filters** – Dimensions are in millimeters and (inches)  
 Catalog Numbers: 22-RF5P7-AS, -AL; 22-RF9P5-AS, -AL; 22-RF10-AL

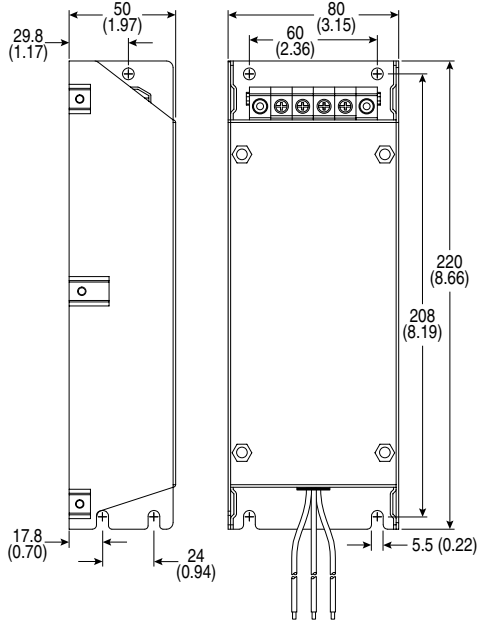

**Figure B.6 Frame B EMC Line Filters** – Dimensions are in millimeters and (inches)  
 Catalog Numbers: 22-RF012-BS, -BL; 22-RF018-BS; 22-RF021-BS, -BL

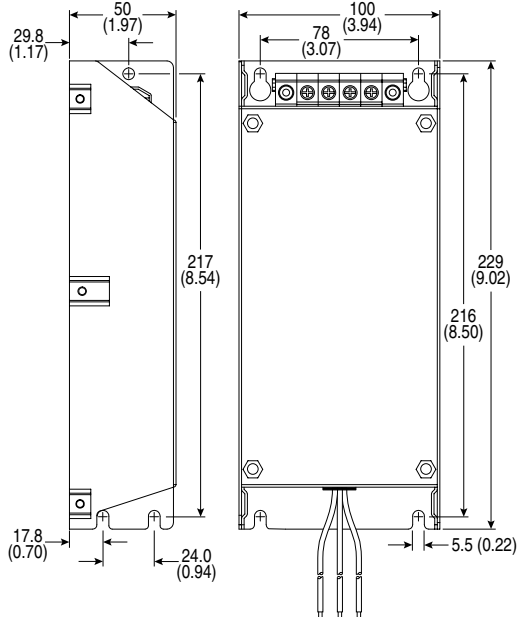

**Notes:**

## RS485 (DSI) Protocol

PowerFlex 4 drives support the RS485 (DSI) protocol to allow efficient operation with Rockwell Automation peripherals. In addition, some Modbus functions are supported to allow simple networking. PowerFlex 4 drives can be multi-dropped on an RS485 network using Modbus protocol in RTU mode.

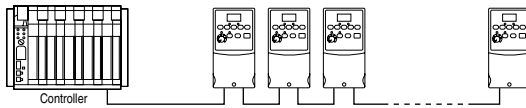

### Network Wiring

Network wiring consists of a shielded 2-conductor cable that is daisy-chained from node to node.

Figure C.1 Network Wiring Diagram

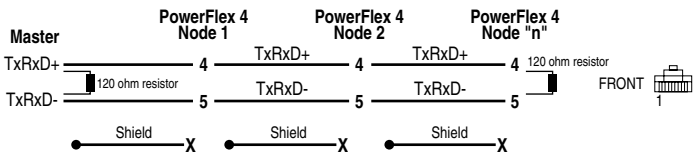

NOTE: The shield is connected at ONLY ONE end of each cable segment.

Only pins 4 and 5 on the RJ45 plug should be wired. The other pins on the PowerFlex 4 RJ45 socket contain power, etc. for other Rockwell Automation peripheral devices and must not be connected.

Wiring terminations on the master controller will vary depending on the master controller used and “TxRxD+” and “TxRxD-” are shown for illustration purposes only. Refer to the master controller’s user manual for network terminations. Note that there is no standard for the “+” and “-” wires, and consequently Modbus device manufacturers interpret them differently. If you have problems with initially establishing communications, try swapping the two network wires at the master controller.

Standard RS485 wiring practices apply. Termination resistors need to be applied at each end of the network cable. RS485 repeaters may need to be used for long cable runs, or if greater than 32 nodes are needed on the network.

Control Terminal 16 on the PowerFlex 4 must also be connected to PE ground (there are two PE terminals on the drive). See [Figure 1.5](#) for more information.

## Parameter Configuration

The following PowerFlex 4 parameters are used to configure the drive to operate on a network.

Parameter	Details	Reference
P036 [Start Source]	Set to 5 "RS485 (DSI) Port" if Start is controlled from the network.	<a href="#">Page 3-9</a>
P038 [Speed Reference]	Set to 5 "RS485 (DSI) Port" if the Speed Reference is controlled from the network.	<a href="#">Page 3-11</a>
A103 [Comm Data Rate]	Sets the data rate for the RS485 (DSI) Port. All nodes on the network must be set to the same data rate.	<a href="#">Page 3-23</a>
A104 [Comm Node Addr]	Sets the node address for the drive on the network. Each device on the network requires a unique node address.	<a href="#">Page 3-23</a>
A105 [Comm Loss Action]	Selects the drive's response to communication problems.	<a href="#">Page 3-24</a>
A106 [Comm Loss Time]	Sets the time that the drive will remain in communication loss before the drive implements A105 [Comm Loss Action].	<a href="#">Page 3-24</a>
A107 [Comm Format]	Sets the transmission mode, data bits, parity and stop bits for the RS485 (DSI) Port. All nodes on the network must be set to the same setting.	<a href="#">Page 3-24</a>

## Supported Modbus Function Codes

The peripheral interface (DSI) used on PowerFlex 4 drives supports some of the Modbus function codes.

Modbus Function Code	Command
03	Read Holding Registers
06	Preset (Write) Single Register

**Important:** Modbus devices can be 0-based (registers are numbered starting at 0) or 1-based (registers are numbered starting at 1). Depending on the Modbus Master used, the register addresses listed on the following pages may need to be offset by +1. For example, Logic Command may be register address 8192 for some master devices (e.g. ProSoft 3150-MCM SLC Modbus scanner) and 8193 for others (e.g. PanelViews).

## Writing (06) Logic Command Data

The PowerFlex 4 drive can be controlled via the network by sending Function Code 06 writes to register address 8192 (Logic Command). P036 [Start Source] must be set to 5 “RS485 (DSI) Port” in order to accept the commands.

Logic Command			
Address (Decimal)	Bit(s)	Description	
8192	0	1 = Stop, 0 = Not Stop	
	1	1 = Start, 0 = Not Start	
	2	1 = Jog, 0 = No Jog	
	3	1 = Clear Faults, 0 = Not Clear Faults	
	5,4	00	No Command
		01	Forward Command
		10	Reverse Command
		11	Change Direction (Toggle)
	6	Not Used	
	7	Not Used	
	9,8	00	No Command
		01	Accel Rate 1 Enable
		10	Accel Rate 2 Enable
		11	Hold Accel Rate Selected
	11,10	00	No Command
01		Decel Rate 1 Enable	
10		Decel Rate 2 Enable	
11		Hold Decel Rate Selected	
14,13,12	000	No Command	
	001	Freq. Source = P036 [Start Source]	
	010	Freq. Source = A069 [Internal Freq]	
	011	Freq. Source = Comms (Addr 8193)	
	100	A070 [Preset Freq 0]	
	101	A071 [Preset Freq 1]	
	110	A072 [Preset Freq 2]	
111	A073 [Preset Freq 3]		
15	Not Used		

## Writing (06) Reference

The Speed Reference to a PowerFlex 4 drive can be controlled via the network by sending Function Code 06 writes to register address 8193 (Reference). P038 [Speed Reference] must be set to 5 “RS485 (DSI) Port” in order to accept the Speed Reference.

Reference	
Address (Decimal)	Description
8193	A decimal value entered as xxx.x where the decimal point is fixed. For example, a decimal “100” equals 10.0 Hz and “543” equals 54.3 Hz.

## Reading (03) Logic Status Data

The PowerFlex 4 Logic Status data can be read via the network by sending Function Code 03 reads to register address 8448 (Logic Status).

Logic Status		
Address (Decimal)	Bit(s)	Description
8448	0	1 = Ready, 0 = Not Ready
	1	1 = Active (Running), 0 = Not Active
	2	1 = Cmd Forward, 0 = Cmd Reverse
	3	1 = Rotating Forward, 0 = Rotating Reverse
	4	1 = Accelerating, 0 = Not Accelerating
	5	1 = Decelerating, 0 = Not Decelerating
	6	1 = Alarm, 0 = No Alarm
	7	1 = Faulted, 0 = Not Faulted
	8	1 = At Reference, 0 = Not At Reference
	9	1 = Reference Controlled by Comm
	10	1 = Operation Cmd Controlled by Comm
	11	1 = Parameters have been locked
	12	Digital Input 1 Status
	13	Digital Input 2 Status
	14	Not Used
15	Not Used	

## Reading (03) Feedback

The Feedback (Output Frequency) from the PowerFlex 4 drive can be read via the network by sending Function Code 03 reads to register address 8451 (Feedback).

Feedback <sup>(1)</sup>	
Address (Decimal)	Description
8451	A xxx.x decimal value where the decimal point is fixed. For example, a decimal "123" equals 12.3 Hz and "300" equals 30.0 Hz.

<sup>(1)</sup> Returns the same data as Reading (03) Parameter d001 [Output Freq].

## Reading (03) Drive Error Codes

The PowerFlex 4 Error Code data can be read via the network by sending Function Code 03 reads to register address 8449 (Drive Error Codes).

Logic Status		
Address (Decimal)	Value (Decimal)	Description
8449	0	No Fault
	2	Auxiliary Input
	3	Power Loss
	4	Undervoltage
	5	Overvoltage
	6	Motor Stalled
	7	Motor Overload
	8	Heatsink Overtemperature
	12	HW Overcurrent (300%)
	13	Ground Fault
	29	Analog Input Loss
	33	Auto Restart Tries
	38	Phase U to Ground Short
	39	Phase V to Ground Short
	40	Phase W to Ground Short
	41	Phase UV Short
	42	Phase UW Short
	43	Phase VW Short
	63	Software Overcurrent
	64	Drive Overload
70	Power Unit Fail	
80	AutoTune Fail	
81	Communication Loss	
100	Parameter Checksum Error	
122	I/O Board Fail	

## Reading (03) and Writing (06) Drive Parameters

To access drive parameters, the Modbus register address equals the parameter number. For example, a decimal “1” is used to address Parameter d001 [Output Freq] and decimal “39” is used to address Parameter P039 [Accel Time 1].

## Additional Information

Refer to <http://www.ab.com/drives/> for additional information.

**Notes:**

## A

AC Supply  
  Ground, **1-4**  
  Source, **1-3**  
  Ungrounded, **1-3**  
Advanced Program Group  
  Parameters, **3-13**  
Ambient Temperatures, **1-2**  
Armored Cable, **1-8**  
Auto Rstrt Tries Fault, **4-4**  
Auxiliary Input Fault, **4-3**

## B

Before Applying Power, **2-1, 2-2**  
Bus Capacitors, Discharging, **P-3**

## C

Cable Length, **1-12**  
Cable, Power, **1-8**  
Capacitors, Discharging, **P-3**  
Catalog Number Explanation, **P-4**  
CE Conformity, **1-18**  
Checklist, Start-Up, **2-1, 2-2**  
Circuit Breakers  
  Input, **1-6**  
Comm Loss Fault, **4-4**  
Command Sources for Start and  
  Speed, **1-16**  
Common Symptoms and Corrective  
  Action, **4-5**  
Contactors, Input, **1-11**  
Control, 2 and 3 Wire, **1-14, 1-15**  
Conventions, Manual, **P-2**  
Cover, Opening, **1-1**  
Cross Reference, Parameter  
  by Name, **3-25**

## D

Dimensions  
  Drive, **B-5**  
  Minimum Clearances, **1-2**  
Discharging Bus Capacitors, **P-3**  
Display, **2-3**

Display Group Parameters, **3-3**  
Distribution Systems, Ungrounded,  
  **1-3**  
Drive Frame Size, **P-2, B-5**  
Drive Grounding, **1-4**  
Drive Overload Fault, **4-4**  
Drive Ratings, **P-4, A-1**  
DriveExecutive, **3-1**  
DriveExplorer, **3-1**

## E

Earthing, see *Grounding*  
EMC/RFI  
  Grounding, Filter, **1-5**  
  Interference, **1-18**  
Enclosure Rating, Changing, **1-2**  
ESD, Static Discharge, **P-3**

## F

Faults  
  Auto Rstrt Tries, **4-4**  
  Auxiliary Input, **4-3**  
  Comm Loss, **4-4**  
  Drive Overload, **4-4**  
  Ground Fault, **4-3**  
  Heatsink OvrTmp, **4-3**  
  HW OverCurrent, **4-3**  
  I/O Board Fail, **4-4**  
  Motor Overload, **4-3**  
  Motor Stalled, **4-3**  
  OverVoltage, **4-3**  
  Parameter Checksum, **4-4**  
  Phase Short, **4-4**  
  Phase to Ground Short, **4-4**  
  Power Loss, **4-3**  
  Power Unit, **4-4**  
  SW OverCurrent, **4-4**  
  UnderVoltage, **4-3**  
Filter, RFI, **1-5**  
Frame Designations, **P-2, A-1, B-5**  
Fuses  
  Input, **1-6**  
  Ratings, **A-1**

## G

- General Precautions, **P-3**
- Ground Fault, **4-3**
- Grounding
  - Filter, **1-5**
  - General, **1-4**

## H

- Heatsink OvrTmp Fault, **4-3**
- HW OverCurrent Fault, **4-3**

## I

- I/O
  - Wiring, **1-11**
  - Wiring Examples, **1-14, 1-15**
- I/O Board Fail Fault, **4-4**
- Input Contactor, **1-11**
- Input Fusing, **1-6**
- Input Potentiometer, **1-14**
- Input Power Conditioning, **1-4**
- Installation, **1-1**
- Integral Keypad, **2-3**
- Interference, EMC/RFI, **1-18**

## K

- Keypad, **2-3**

## L

- LEDs, **2-3**

## M

- Minimum Clearances, **1-2**
- Motor Cable Length, **1-9**
- Motor Overload Fault, **4-3**
- Motor Stalled Fault, **4-3**
- motor starter, **1-6**
- Mounting Options and Clearances, **1-2**
- MOVs, **1-3**

## O

- Opening the Cover, **1-1**
- Operating Temperatures, **1-2**
- Operator Interface, **2-3**
- OverVoltage Fault, **4-3**

## P

- Parameter
  - Descriptions, **3-1**
  - Types, **3-1**
  - Viewing and Editing, **2-4**
- Parameter Checksum Fault, **4-4**
- Parameter Cross Reference
  - by Name, **3-25**
- Parameters
  - Advanced Program Group, **3-13**
  - Display Group, **3-3**
  - Program Group, **3-8**
- PE Ground, **1-5**
- Phase Short Fault, **4-4**
- Phase to Ground Fault, **4-4**
- Potentiometer, Wiring, **1-14**
- Power Cables/Wiring, **1-8**
- Power Conditioning, Input, **1-4**
- Power Loss Fault, **4-3**
- Power Unit Fault, **4-4**
- Powering Up the Drive, **2-1, 2-2**
- Precautions, General, **P-3**
- Product Selection, **B-1**
- Program Group Parameters, **3-8**
- Programming, **3-1**

## R

- Ratings, **A-1**
- Reflective Wave Protection, **1-9**
- Removing Cover, **1-1**
- Repeated Start/Stop, **1-11**
- Repeated Start/Stop Precautions, **1-11**
- RFI, see *EMC/RFI*
- RWR (Reflective Wave Reducer), **1-9**

## S

- Safety Ground, **1-5**
- Shielded Power Cables, **1-8**
- Short Circuit Protection, **1-6**
- Software, **3-1**
- Start and Speed Reference Selection and Control, **1-16, 1-17**
- Start/Stop, Repeated, **1-11**

Start-Up Checklist, **2-1, 2-2**  
Static Discharge, ESD, **P-3**  
Status LEDs, **2-3**  
Supply Source, AC, **1-3**  
SW OverCurrent Fault, **4-4**  
System Grounding, **1-4**

## **T**

Terminal Block  
  I/O, **1-12**  
  Power, **1-10**  
Three Wire Control, **1-14, 1-15**  
Two Wire Control, **1-14, 1-15**

## **U**

UnderVoltage Fault, **4-3**  
Ungrounded Supply, **1-3**  
Unshielded Power Cables, **1-8**

## **W**

Wiring, **1-1**  
  Block Diagram, **1-13**  
  I/O, **1-11**  
  I/O Examples, **1-14, 1-15**  
  Potentiometer, **1-14**  
  Power, **1-8**

**Notes:**





[www.rockwellautomation.com](http://www.rockwellautomation.com)

**Corporate Headquarters**

Rockwell Automation, 777 East Wisconsin Avenue, Suite 1400, Milwaukee, WI, 53202-5302 USA, Tel: (1) 414.212.5200, Fax: (1) 414.212.5201

**Headquarters for Allen-Bradley Products, Rockwell Software Products and Global Manufacturing Solutions**

Americas: Rockwell Automation, 1201 South Second Street, Milwaukee, WI 53204-2496 USA, Tel: (1) 414.382.2000, Fax: (1) 414.382.4444  
Europe/Middle East/Africa: Rockwell Automation SA/NV, Vorstaan/Boulevard du Souverain 36, 1170 Brussels, Belgium, Tel: (32) 2 663 0600, Fax: (32) 2 663 0640  
Asia Pacific: Rockwell Automation, 27/F Citicorp Centre, 18 Whitfield Road, Causeway Bay, Hong Kong, Tel: (852) 2987 4788, Fax: (852) 2508 1846

**Headquarters for Dodge and Reliance Electric Products**

Americas: Rockwell Automation, 6040 Ponders Court, Greenville, SC 29615-4617 USA, Tel: (1) 864.297.4800, Fax: (1) 864.281.2433  
Europe/Middle East/Africa: Rockwell Automation, Brühlstraße 22, D-74834 Elztal-Dallau, Germany, Tel: (49) 6261 9410, Fax: (49) 6261 17741  
Asia Pacific: Rockwell Automation, 55 Newton Road, #11-01/02 Revenue House, Singapore 307987, Tel: (65) 6356-3077, Fax: (65) 6356-9011

**U.S. Allen-Bradley Drives Technical Support**

Tel: (1) 262.512.8176, Fax: (1) 262.512.2222, Email: [support@drives.ra.rockwell.com](mailto:support@drives.ra.rockwell.com), Online: [www.ab.com/support/abdrives](http://www.ab.com/support/abdrives)

Publication 22A-UM001C-EN-E – June 2002

Supersedes February 2002

Copyright © 2002 Rockwell Automation, Inc. All rights reserved.