

SJ700₂Series Inverter Instruction Manual

- Three-phase Input 200V Class
- Three-phase Input 400V Class

U.S. Version Models



European Version Models



Manual Number: NB206XA
October 2009

After reading this manual,
keep it handy for future reference.

Hitachi Industrial Equipment Systems Co., Ltd.

Safety Messages

For the best results with the SJ7002 Series inverter, carefully read this manual and all of the warning labels attached to the inverter before installing and operating it, and follow the instructions exactly. Keep this manual handy for quick reference.

Definitions and Symbols

A safety instruction (message) includes a hazard alert symbol and a signal word, WARNING or CAUTION. Each signal word has the following meaning:



This symbol indicates **HIGH VOLTAGE**. It calls your attention to items or operations that could be dangerous to you and other persons operation this equipment. Read the message and follow the instructions carefully.



This symbol is the “Safety Alert Symbol.” It occurs with either of two signal words: CAUTION or WARNING, as described below.



WARNING: Indicates a potentially hazardous situation that, if not avoided, can result in serious injury or death.



CAUTION: Indicates a potentially hazardous situation that, if not avoided, can result in minor to moderate injury, or serious damage to the product. The situation described in the **CAUTION** may, if not avoided, lead to serious results. Important safety measures are described in CAUTION (as well as WARNING), so be sure to observe them.



STEP: A step is one of a series of action steps required to accomplish a goal. The number of the step will be contained in the step symbol.



NOTE: Notes indicate an area or subject of special merit, emphasizing either the product’s capabilities or common errors in operation or maintenance.



TIP: Tips give a special instruction that can save time or provide other benefits while installing or using the product. The tip calls attention to an idea that may not be obvious to first-time users of the product.

Hazardous High Voltage



HIGH VOLTAGE: Motor control equipment and electronic controllers are connected to hazardous line voltages. When servicing drives and electronic controllers, there may be exposed components with housings or protrusions at or above line potential. Extreme care should be taken to protect against shock.

Stand on an insulating pad and make it a habit to use only one hand when checking components. Always work with another person in case an emergency occurs. Disconnect power before checking controllers or performing maintenance. Be sure equipment is properly grounded. Wear safety glasses whenever working on electronic controllers or rotating machinery.

General Precautions - Read These First!



WARNING: This equipment should be installed, adjusted, and serviced by qualified electrical maintenance personnel familiar with the construction and operation of the equipment and the hazards involved. Failure to observe this precaution could result in bodily injury.



WARNING: The user is responsible for ensuring that all driven machinery, drive train mechanism not supplied by Hitachi Industrial Equipment Systems Co., Ltd., and process line material are capable of safe operation at an applied frequency of 150% of the maximum selected frequency range to the AC motor. Failure to do so can result in destruction of equipment and injury to personnel should a single-point failure occur.



WARNING: For equipment protection, install a ground leakage type breaker with a fast response circuit capable of handling large currents. The ground fault protection circuit is not designed to protect against personal injury.



HIGH VOLTAGE: HAZARD OF ELECTRICAL SHOCK. DISCONNECT INCOMING POWER BEFORE WORKING ON THIS CONTROL.



WARNING: Wait at least ten (10) minutes after turning OFF the input power supply before performing maintenance or an inspection. Otherwise, there is the danger of electric shock.



CAUTION: These instructions should be read and clearly understood before working on SJ7002 series equipment.



CAUTION: Proper grounds, disconnecting devices and other safety devices and their location are the responsibility of the user and are not provided by Hitachi Industrial Equipment Systems Co., Ltd.



CAUTION: Be sure to connect a motor thermal disconnect switch or overload device to the SJ7002 series controller to assure that the inverter will shut down in the event of an overload or an overheated motor.



HIGH VOLTAGE: Dangerous voltage exists until power light is OFF. Wait at least 10 minutes after input power is disconnected before performing maintenance.



CAUTION: This equipment has high leakage current and must be permanently (fixed) hard-wired to earth ground via two independent cables.



WARNING: Rotating shafts and above-ground electrical potentials can be hazardous. Therefore, it is strongly recommended that all electrical work conform to the National Electrical Codes and local regulations. Installation, alignment and maintenance should be performed only by qualified personnel.

Factory-recommended test procedures included in the instruction manual should be followed. Always disconnect electrical power before working on the unit.

**CAUTION:**

- a) Motor must be connected to protective ground via low resistive path ($< 0.1\Omega$)
- b) Any motor used must be of a suitable rating.
- c) Motors may have hazardous moving parts. In this event suitable protection must be provided.



CAUTION: Alarm connection may contain hazardous live voltage even when inverter is disconnected. When removing the front cover for maintenance or inspection, confirm that incoming power for alarm connection is completely disconnected.



CAUTION: Hazardous (main) terminals for any interconnection (motor, contact breaker, filter, etc.) must be inaccessible in the final installation.



CAUTION: The end application must be in accordance with BS EN60204-1. Refer to the section [“Step-by-Step Basic Installation” on page 2-6](#). The diagram dimensions are to be suitably amended for your application.



CAUTION: Connection to field wiring terminals must be reliably fixed having two independent means of mechanical support. Using a termination with cable support (figure below), or strain relief, cable clamp, etc.

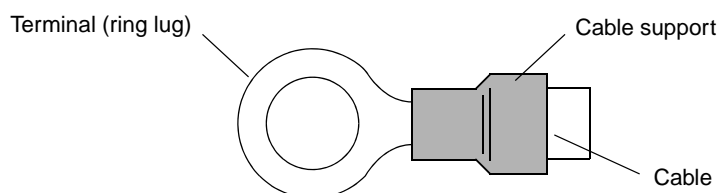









CAUTION: A three-pole disconnection device must be fitted to the incoming main power supply close to the inverter. Additionally, a protection device meeting IEC947-1/IEC947-3 must be fitted at this point (protection device data shown in [“Determining Wire and Fuse Sizes” on page 2-18](#)).







NOTE: The above instructions, together with any other requirements are highlighted in this manual, and must be followed for continued LVD (European Low Voltage Directive) compliance.





Index to Warnings and Cautions in This Manual

Installation—Cautions for Mounting Procedures



-  CAUTION: Be sure to install the unit on flame-resistant material such as a steel plate. Otherwise, there is the danger of fire. [2-6](#)
-  CAUTION: Be sure not to place any flammable materials near the inverter. Otherwise, there is the danger of fire. [2-6](#)
-  CAUTION: Be sure not to let the foreign matter enter vent openings in the inverter housing, such as wire clippings, spatter from welding, metal shavings, dust, etc. Otherwise, there is the danger of fire. [2-6](#)
-  CAUTION: Be sure to install the inverter in a place that can bear the weight according to the specifications in the text (Chapter 1, Specifications Tables). Otherwise, it may fall and cause injury to personnel. [2-6](#)
-  CAUTION: Be sure to install the unit on a perpendicular wall that is not subject to vibration. Otherwise, it may fall and cause injury to personnel. [2-6](#)
-  CAUTION: Be sure not to install or operate an inverter that is damaged or has missing parts. Otherwise, it may cause injury to personnel. [2-6](#)
-  CAUTION: Be sure to install the inverter in a well-ventilated room that does not have direct exposure to sunlight, a tendency for high temperature, high humidity or dew condensation, high levels of dust, corrosive gas, explosive gas, inflammable gas, grinding-fluid mist, salt air, etc. Otherwise, there is the danger of fire. [2-6](#)
-  CAUTION: Be sure to maintain the specified clearance area around the inverter and to provide adequate ventilation. Otherwise, the inverter may overheat and cause equipment damage or fire. [2-8](#)

Wiring—Warnings for Electrical Practices and Wire Specifications

-  WARNING: Use 75°C Cu wire only or equivalent. [2-17](#)
-  WARNING: Open Type Equipment. For models SJ700–750H to SJ700–4000H. [2-17](#)
-  WARNING: A Class 2 circuit wired with Class 1 wire or equivalent. [2-17](#)
-  WARNING: Suitable for use on a circuit capable of delivering not more than 100,000 rms symmetrical amperes, 240 V maximum. For models with suffix L. [2-17](#)
-  WARNING: Suitable for use on a circuit capable of delivering not more than 100,000 rms symmetrical amperes, 480 V maximum. For models with suffix H. [2-17](#)

-  HIGH VOLTAGE: Be sure to ground the unit. Otherwise, there is a danger of electric shock and/or fire. [2-17](#)
-  HIGH VOLTAGE: Wiring work shall be carried out only by qualified personnel. Otherwise, there is a danger of electric shock and/or fire. [2-17](#)
-  HIGH VOLTAGE: Implement wiring after checking that the power supply is OFF. Otherwise, you may incur electric shock and/or fire. [2-17](#)
-  HIGH VOLTAGE: Do not connect wiring to an inverter or operate an inverter that is not mounted according the instructions given in this manual. Otherwise, there is a danger of electric shock and/or injury to personnel. [2-17](#)

Wiring—Cautions for Electrical Practices

-  CAUTION: Be sure that the input voltage matches the inverter specifications: • Three phase 200 to 240V 50/60Hz • Three phase 380 to 480V 50/60Hz [2-25](#)
-  CAUTION: Be sure not to power a three-phase-only inverter with single phase power. Otherwise, there is the possibility of damage to the inverter and the danger of fire. [2-25](#)
-  CAUTION: Be sure not to connect an AC power supply to the output terminals. Otherwise, there is the possibility of damage to the inverter and the danger of injury and/or fire. [2-25](#)

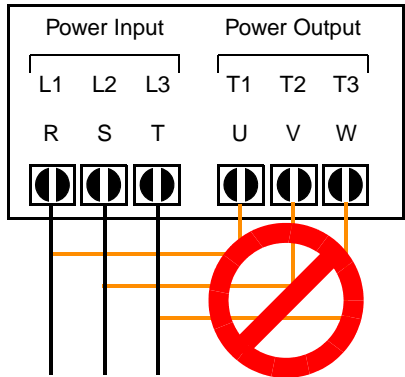

NOTE:
 L1, L2, L3: Three-phase 200 to 240V 50/60 Hz
 Three-phase 380 to 480V 50/60 Hz



CAUTION: Fasten the screws with the specified fastening torque in the table below. Check for any loosening of screws. Otherwise, there is the danger of fire. [2-20](#)



CAUTION: Remarks for using ground fault interrupter breakers in the main power supply: Adjustable frequency inverters with CE-filters (RFI-filter) and shielded (screened) motor cables have a higher leakage current toward Earth GND. Especially at the moment of switching ON this can cause an inadvertent trip of ground fault interrupter breakers. Because of the rectifier on the input side of the inverter there is the possibility to stall the switch-off function through small amounts of DC current. Please observe the following: • Use only short time-invariant and pulse current-sensitive ground fault interrupter breakers with higher trigger current. • Other components should be secured with separate ground fault interrupter breakers. • Ground fault interrupter breakers in the power input wiring of an inverter are not an absolute protection against electric shock. [2-25](#)



CAUTION: Be sure to install a fuse in each phase of the main power supply to the inverter. Otherwise, there is the danger of fire. [2-25](#)



CAUTION: For motor leads, ground fault interrupter breakers and electromagnetic contactors, be sure to size these components properly (each must have the capacity for rated current and voltage). Otherwise, there is the danger of fire. [2-25](#)



CAUTION: Failure to remove all vent opening covers before electrical operation may result in damage to the inverter. [2-26](#)

Powerup Test Caution Messages



CAUTION: The heat sink fins will have a high temperature. Be careful not to touch them. Otherwise, there is the danger of getting burned. [2-27](#)



CAUTION: The operation of the inverter can be easily changed from low speed to high speed. Be sure to check the capability and limitations of the motor and machine before operating the inverter. Otherwise, there is the danger of injury. [2-27](#)

















CAUTION: If you operate a motor at a frequency higher than the inverter standard default setting (50Hz/60Hz), be sure to check the motor and machine specifications with the respective manufacturer. Only operate the motor at elevated frequencies after getting their approval. Otherwise, there is the danger of equipment damage and/or injury to personnel. [2-28](#)









CAUTION: Check the following before and during the powerup test. Otherwise, there is the danger of equipment damage. • Is the shorting bar between the [P] and [PD] terminals installed? DO NOT power or operate the inverter if the jumper is removed. • Is the direction of the motor rotation correct? • Did the inverter trip during acceleration or deceleration? • Were the rpm and frequency meter readings as expected? • Were there any abnormal motor vibrations or noise? [2-28](#)





Warnings for Operations and Monitoring

	WARNING: Be sure to turn ON the input power supply only after closing the front case. While the inverter is energized, be sure not to open the front case. Otherwise, there is the danger of electric shock. 4-3
	WARNING: Be sure not to operate electrical equipment with wet hands. Otherwise, there is the danger of electric shock. 4-3
	WARNING: While the inverter is energized, be sure not to touch the inverter terminals even when the motor is stopped. Otherwise, there is the danger of electric shock. 4-3
	WARNING: If the Retry Mode is selected, the motor may suddenly restart after a trip stop. Be sure to stop the inverter before approaching the machine (be sure to design the machine so that safety for personnel is secure even if it restarts.) Otherwise, it may cause injury to personnel. 4-3
	WARNING: If the power supply is cut OFF for a short period of time, the inverter may restart operation after the power supply recovers if the Run command is active. If a restart may pose danger to personnel, so be sure to use a lock-out circuit so that it will not restart after power recovery. Otherwise, it may cause injury to personnel. 4-3
	WARNING: The Stop Key is effective only when the Stop function is enabled. Be sure to enable the Stop Key separately from the emergency stop. Otherwise, it may cause injury to personnel. 4-3
	WARNING: During a trip event, if the alarm reset is applied and the Run command is present, the inverter will automatically restart. Be sure to apply the alarm reset only after verifying the Run command is OFF. Otherwise, it may cause injury to personnel. 4-3
	WARNING: Be sure not to touch the inside of the energized inverter or to put any conductive object into it. Otherwise, there is a danger of electric shock and/or fire. 4-3
	WARNING: If power is turned ON when the Run command is already active, the motor will automatically start and injury may result. Before turning ON the power, confirm that the RUN command is not present. 4-3
	WARNING: When the Stop key function is disabled, pressing the Stop key does not stop the inverter, nor will it reset a trip alarm. 4-3
	WARNING: Be sure to provide a separate, hard-wired emergency stop switch when the application warrants it. 4-3
	WARNING: If the power is turned ON and the Run command is already active, the motor starts rotation and is dangerous! Before turning power ON, confirm that the external Run command is not active. 4-15
	WARNING: After the Reset command is given and the alarm reset occurs, the motor will restart suddenly if the Run command is already active. Be sure to set the alarm reset after verifying that the Run command is OFF to prevent injury to personnel. 4-24
	WARNING: You may need to disconnect the load from the motor before performing auto-tuning. The inverter runs the motor forward and backward for several seconds without regard to load movement limits. 4-71

Cautions for Operations and Monitoring

-  CAUTION: The heat sink fins will have a high temperature. Be careful not to touch them. Otherwise, there is the danger of getting burned. [4-2](#)
-  CAUTION: The operation of the inverter can be easily changed from low speed to high speed. Be sure check the capability and limitations of the motor and machine before operating the inverter. Otherwise, it may cause injury to personnel. [4-2](#)
-  CAUTION: If you operate a motor at a frequency higher than the inverter standard default setting (50Hz/60Hz), be sure to check the motor and machine specifications with the respective manufacturer. Only operate the motor at elevated frequencies after getting their approval. Otherwise, there is the danger of equipment damage. [4-2](#)
-  CAUTION: It is possible to damage the inverter or other devices if your application exceeds the maximum current or voltage characteristics of a connection point. [4-7](#)
-  CAUTION: Be careful not to turn PID Clear ON and reset the integrator sum when the inverter is in Run Mode (output to motor is ON). Otherwise, this could cause the motor to decelerate rapidly, resulting in a trip. [4-26](#)
-  CAUTION: When the motor runs at lower speeds, the cooling effect of the motor's internal fan decreases. [4-52](#)
-  CAUTION: If the inverter capacity is more than twice the capacity of the motor in use, the inverter may not achieve its full performance specifications. [4-74](#)

Warnings and Cautions for Troubleshooting and Maintenance

-  WARNING: Wait at least ten (10) minutes after turning OFF the input power supply before performing maintenance or an inspection. Otherwise, there is the danger of electric shock. [6-2](#)
-  WARNING: Make sure that only qualified personnel will perform maintenance, inspection, and part replacement. Before starting to work, remove any metallic objects from your person (wristwatch, bracelet, etc.). Be sure to use tools with insulated handles. Otherwise, there is a danger of electric shock and/or injury to personnel. [6-2](#)
-  WARNING: Never remove connectors by pulling on its wire leads (wires for cooling fan and logic P.C. board). Otherwise, there is danger of fire due to wire breakage and/or injury to personnel. [6-2](#)
-  CAUTION: Do not connect the megger to any control circuit terminals such as intelligent I/O, analog terminals, etc. Doing so could cause damage to the inverter. [6-19](#)
-  CAUTION: Never test the withstand voltage (HIPOT) on the inverter. The inverter has a surge protector between the main circuit terminals above and the chassis ground. [6-19](#)



WARNING: The screws that retain the capacitor bank assembly are part of the electrical circuit of the high-voltage internal DC bus. Be sure that all power has been disconnected from the inverter, and that you have waited at least 10 minutes before accessing the terminals or screws. Be sure the charge lamp is extinguished. Otherwise, there is the danger of electrocution to personnel. 6-21



CAUTION: Do not operate the inverter unless you have replaced the two screws that connect the capacitor bank assembly to the internal DC bus. Otherwise, damage to the inverter may occur. 6-21



HIGH VOLTAGE: Be careful not to touch wiring or connector terminals when working with the inverters and taking measurements. Be sure to place the measurement circuitry above in an insulated housing before using them. 6-26

General Warnings and Cautions



WARNING: Never modify the unit. Otherwise, there is a danger of electric shock and/or injury.



CAUTION: Withstand voltage tests and insulation resistance tests (HIPOT) are executed before the units are shipped, so there is no need to conduct these tests before operation.



CAUTION: Do not attach or remove wiring or connectors when power is applied. Also, do not check signals during operation.



CAUTION: Do not stop operation by switching OFF electromagnetic contactors on the primary or secondary sides of the inverter.

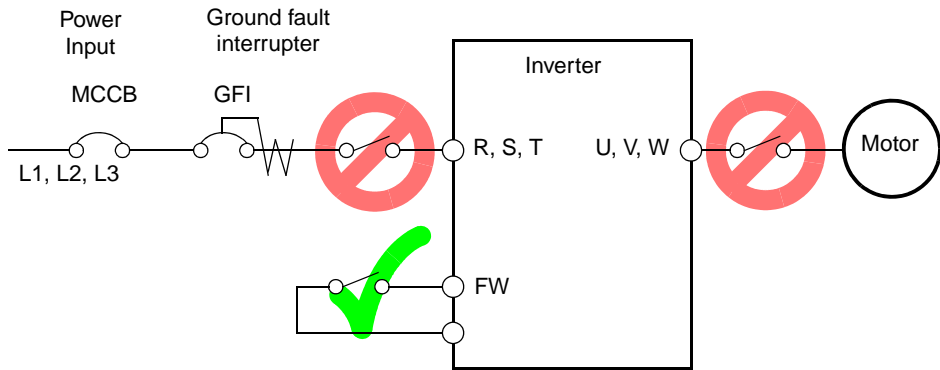

When there has been a sudden power failure while a Run command is active, then the unit may restart operation automatically after the power failure has ended. If there is a possibility that such an occurrence may harm humans, then install an electromagnetic contactor on the power supply side, so that the circuit does not allow automatic restarting after the power supply recovers. If an optional remote operator is used and the retry function has been selected, this will also allow automatic restarting when a Run command is active. So, please be careful.



CAUTION: Do not insert leading power factor capacitors or surge absorbers between the output terminals of the inverter and motor.

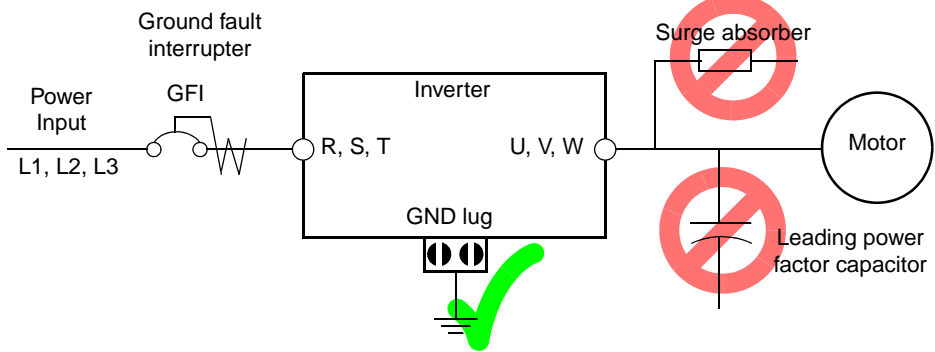

CAUTION: Be sure to connect the grounding terminal to earth ground.



CAUTION: When inspecting the unit, be sure to wait 10 minutes after tuning OFF the power supply before opening the cover.



CAUTION: SUPPRESSION FOR NOISE INTERFERENCE FROM INVERTER

The inverter uses many semiconductor switching elements such as transistors and IGBTs. Thus, a radio receiver or measuring instrument located near the inverter is susceptible to noise interference.

To protect the instruments from erroneous operation due to noise interference, they should be used well away from the inverter. It is also effective to shield the whole inverter structure. The addition of an EMI filter on the input side of the inverter also reduces the effect of noise from the commercial power line on external devices.

Note that the external dispersion of noise from the power line can be minimized by connecting an EMI filter on the primary side of inverter.

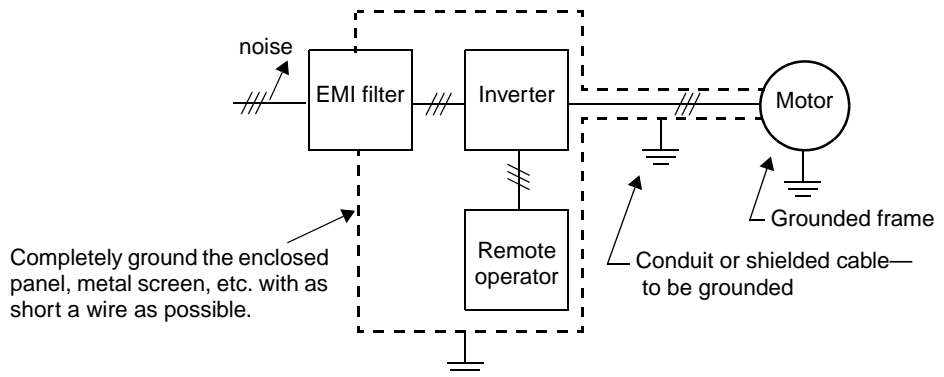
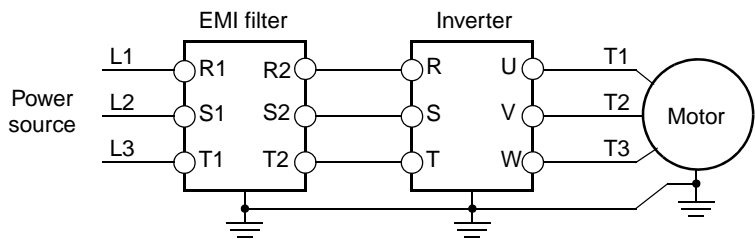



**CAUTION: MOTOR TERMINAL VOLTAGE SURGE SUPPRESSION FILTER
(For 400 V CLASS Inverters)**

In a system using an inverter with the voltage control PWM system, a voltage surge caused by the cable constants such as the cable length (especially when the distance between the motor and inverter is 10 m or more) and cabling method may occur at the motor terminals. A dedicated filter of the 400 V class for suppressing this voltage surge is available. Be sure to install a filter in this situation. (See “[LCR filter](#)” on page 5-2, part type HRL-xxxC.)



CAUTION: EFFECTS OF POWER DISTRIBUTION SYSTEMS ON INVERTERS

In the cases below involving a general-purpose inverter, a large peak current can flow on the power supply side, sometimes destroying the converter module:

1. The unbalance factor of the power supply is 3% or higher.
2. The power supply capacity is at least 10 times greater than the inverter capacity (or the power supply capacity is 500 kVA or more).
3. Abrupt power supply changes are expected, due to conditions such as:
 - a. Several inverters are interconnected with a short bus.
 - b. A thyristor converter and an inverter are interconnected with a short bus.
 - c. An installed phase advance capacitor opens and closes.

Where these conditions exist or when the connected equipment must be highly reliable, you **MUST** install an input-side AC reactor of 3% (at a voltage drop at rated current) with respect to the supply voltage on the power supply side. Also, where the effects of an indirect lightning strike are possible, install a lightning conductor.



CAUTION: EFFECTS OF SHARING POWER SOURCE BETWEEN INVERTER AND OTHER MOTORS

An electric cooling fan for the motor shall be powered from another system. A motor directly connected to the power source shall also be powered from another system. If they are powered from the same system as the inverter, an insufficient voltage protection error (E09) or an instantaneous power failure protection error (E16) may occur when the inverter is turned OFF.



CAUTION: Do not install inverters in a corner-grounded Delta distribution system. The resulting line imbalance will cause premature line fuse failure and failure of the inverter input bridge rectifier. Install in a balanced Delta or Wye distribution system only.



CAUTION: When the EEPROM error E8 occurs, be sure to confirm the setting values again.



CAUTION: When using *normally closed* active state settings (C011 to C019) for externally commanded Forward or Reverse terminals [FW] or [RV], the inverter may start automatically *when the external system is powered OFF or disconnected from the inverter!* So, do not use normally closed active state settings for Forward or Reverse terminals [FW] or [RV] unless your system design protects against unintended motor operation.



CAUTION: Do not discard the inverter with household waste. Contact an industrial waste management company in your area who can treat industrial waste without polluting the environment.



General Caution

CAUTION: In all the illustrations in this manual, covers and safety devices are occasionally removed to describe the details. While operating the product, make sure that the covers and safety devices are placed as they were specified originally and operate it according to the instruction manual.

UL[®] Cautions, Warnings, and Instructions

Wiring Warnings for Electrical Practices and Wire Sizes

The Cautions, Warnings, and instructions in this section summarize the procedures necessary to ensure an inverter installation complies with Underwriters Laboratories[®] guidelines.

The SJ7002 series inverter family is an open-type and/or Enclosed Type 1 (when employing accessory Type 1 Chassis Kit) AC inverter with 3-phase input and 3-phase output. The inverter are intended for use in an enclosure. The inverter supplies adjustable voltage and adjustable frequency to an AC motor. The inverter can automatically maintain a constant volts/Hz ratio to enhance the motor capability throughout its entire speed range.



WARNING: Use 65/75°C Cu wire only or equivalent. For SJ700 series except SJ700-300Lxx and SJ700-370Lxx.



WARNING: Use 75°C Cu wire only or equivalent. For SJ700-300Lxx and SJ700-370Lxx.



WARNING: Suitable for use on a circuit capable of delivering not more than 100,000 rms symmetrical amperes with 240 V maximum. For models with suffix L (200V class).



WARNING: Suitable for use on a circuit capable of delivering not more than 100,000 rms symmetrical amperes with 480 V maximum. For models with suffix H (400V class).



WARNING: The inverter must be installed in an environment that is rated for at least Pollution Degree 2 or equivalent.



WARNING: The ambient temperature must not exceed 50°C.



WARNING: The capacitor discharge time is 10 minutes or more. (Caution: Care must be taken to avoid the risk of electric shock.)



WARNING: Each model of the inverter has a solid-state overload protection circuit or an equivalent feature for the motor.

Terminal Tightening Torque and Wire Size

The wire size range and tightening torque for field wiring terminals are presented in the table below.

Input Voltage	Motor Output		200V Inverter Model	Wire Size Range (AWG)	Torque	
	HP	kW			ft-lbs	(N-m)
200V	0.5	0.4	SJ700-004LFU2	14 (stranded only)	1.3	1.8
	1	0.75	SJ700-007LFU2	14 (stranded only)	1.3	1.8
	2	1.5	SJ700-015LFU2	14 (stranded only)	1.3	1.8
	3	2.2	SJ700-022LFU2	14 (stranded only)	1.3	1.8
	5	3.7	SJ700-037LFU2	10 (stranded only)	1.3	1.8
	7.5	5.5	SJ700-055LFU2	8	3.0	4.0
	10	7.5	SJ700-075LFU2	6	3.0	4.0
	15	11	SJ700-110LFU2	6-4	3.0	4.0
	20	15	SJ700-150LFU2	2	3.6	4.9
	25	18.5	SJ700-185LFU2	1	3.6	4.9
	30	22	SJ700-220LFU2	1 or 1/0	6.5	8.8
	40	30	SJ700-300LFU2	2/0 or 1/0 1/0	6.5	8.8
	50	37	SJ700-370LFU2	4/0 (prepared wire only) or 1/0 1/0	14.8	20.0
	60	45	SJ700-450LFU2	4/0 (prepared wire only) or 1/0 1/0	14.8	20.0
75	55	SJ700-550LFU2	350 kcmil (prepared wire only) or 2/0 2/0 (prepared wire only)	14.5	19.6	

Input Voltage	Motor Output		400V Inverter Model	Power Terminals	Wire Size Range (AWG)	Torque	
	HP	kW				ft-lbs	(N-m)
400V	0.5	0.75	SJ700-007HFU2/E	(All)	14 (stranded only)	1.3	1.8
	1	1.5	SJ700-015HFU2/E	(All)	14 (stranded only)	1.3	1.8
	2	2.2	SJ700-022HFU2/E	(All)	14 (stranded only)	1.3	1.8
	3	4.0	SJ700-040HFU2/E	(All)	14 (stranded only)	1.3	1.8
	7.5	5.5	SJ700-055HFU2/E	(All)	12	3.0	4.0
	10	7.5	SJ700-075HFU2/E	(All)	10	3.0	4.0
	15	11	SJ700-110HFU2/E	(All)	8	3.0	4.0
	20	15	SJ700-150HFU2/E	(All)	6	3.6	4.9
	25	18.5	SJ700-185HFU2/E	(All)	6	3.6	4.9
	30	22	SJ700-220HFU2/E	(All)	6 or 4	6.5	8.8
	40	30	SJ700-300HFU2/E	(All)	3	6.5	8.8
	50	37	SJ700-370HFU2/E	(All)	1	14.8	20.0
	60	45	SJ700-450HFU2/E	(All)	1	14.8	20.0
	75	55	SJ700-550HFU2/E	(All)	2/0	14.5	19.6

Input Voltage	Motor Output		400V Inverter Model	Power Terminals	Wire Size Range (AWG)	Torque	
	HP	kW				ft-lbs	(N-m)
400V	100	75	SJ700-750HFU2/E	(All)	1/0 1/0	14.8	20.0
	125	90	SJ700-900HFU2/E	(All)	1/0 1/0	14.8	20.0
	150	110	SJ700-1100HFU2/E	(All)	3/0 3/0	25.8	35.0
	150	132	SJ700-1320HFE2, SJ700-1500HFU2	(All)	3/0 3/0	25.8	35.0
	250	185	SJ700-1850HFU2/E	[R, S, T, U, V, W]	250 kcmil x 2	55.3	75.0
				[P, PD, N]	300 kcmil x 2	6.0	8.1
				[P, N] Braking unit	1	55.3	75.0
				Earth GND	250 kcmil	28.9	39.2
	400	315	SJ700-3150HFU2/E	[R, S, T, U, V, W]	400 kcmil x 2	32.5	44.0
				[P, PD, N]	500 kcmil x 2	14.8	20
				[P, N] Braking unit	250 kcmil	32.5	44.0
				Earth GND	400 kcmil	28.9	39.2
	500	400	SJ700-4000HFU2/E	[R, S, T, U, V, W]	600 kcmil x 2	38.4	52.0
				[P, PD, N]	800 kcmil x 2	14.8	20
				[P, N] Braking unit	250 kcmil x 2	38.4	52.0
				Earth GND	600 kcmil	28.9	39.2

Fuse and Circuit Breaker Sizes

The inverter's input power wiring must include UL Listed, dual-element, 600V fuses, or UL Listed, inverse-time, 600V circuit breakers.

Input Voltage	Motor Output		200V Inverter Model	Ampere Rating for Fuse or Breaker	Input Voltage	Motor Output		400V Inverter Model	Ampere Rating for Fuse or Breaker
	HP	kW				HP	kW		
200V	0.5	0.4	SJ700-004LFU2	5A	400V	—	—	—	—
	1	0.75	SJ700-007LFU2	10A		1	0.75	SJ700-007HFU2/E	5A
	2	1.5	SJ700-015LFU2	15A		2	1.5	SJ700-015HFU2/E	10A
	3	2.2	SJ700-022LFU2	20A		3	2.2	SJ700-022HFU2/E	10A
	5	3.7	SJ700-037LFU2	30A		5	3.7	SJ700-037HFU2/E	15A
	7.5	5.5	SJ700-055LFU2	30A		7.5	5.5	SJ700-055HFU2/E	15A
	10	7.5	SJ700-075LFU2	40A		10	7.5	SJ700-075HFU2/E	20A
	15	11	SJ700-110LFU2	60A		15	11	SJ700-110HFU2/E	30A
	20	15	SJ700-150LFU2	80A		20	15	SJ700-150HFU2/E	40A
	25	18.5	SJ700-185LFU2	100A		25	18.5	SJ700-185HFU2/E	50A
	30	22	SJ700-220LFU2	125A		30	22	SJ700-220HFU2/E	60A
	40	30	SJ700-300LFU2	150A		40	30	SJ700-300HFU2/E	70A
	50	37	SJ700-370LFU2	175A		50	37	SJ700-370HFU2/E	90A
	60	45	SJ700-450LFU2	225A		60	45	SJ700-450HFU2/E	125A
75	55	SJ700-550LFU2	250A	75	55	SJ700-550HFU2/E	125A		
				100	75	SJ700-750HFU2/E	225A		
				125	90	SJ700-900HFU2/E	225A		
				150	110	SJ700-1100HFU2/E	300A		
				200	150	SJ700-1320HFE2 SJ700-1500HFU2	300A		
				250	185	SJ700-1850HFU2/E	400A		
				400	315	SJ700-3150HFU2/E	700A		
				55	400	SJ700-4000HFU2/E	1000A		

Wire Connectors



WARNING: Field wiring connections must be made by a UL Listed and CSA Certified ring lug terminal connector sized for the wire gauge being used. The connector must be fixed using the crimping tool specified by the connector manufacturer.

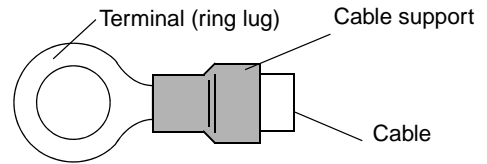

Motor Overload Protection

Hitachi SJ7002 inverters provide solid state motor overload protection, which depends on the proper setting of the following parameters:

- B012 “electronic overload protection”
- B212 “electronic overload protection, 2nd motor”
- B312 “electronic overload protection, 3rd motor”

Set the rated current [Amperes] of the motor(s) with the above parameters. The setting range is $0.2 * \text{rated current}$ to $1.2 * \text{rated current}$.



WARNING: Integral solid state short circuit protection does not provide branch circuit protection. Branch circuit protection must be provided in accordance with the NEC and any additional local codes.



WARNING: When two or more motors are connected to the inverter, they cannot be protected by the electronic overload protection. Install an external thermal relay on each motor.

Table of Contents

Safety Messages

Hazardous High Voltage	i
General Precautions - Read These First!	ii
Index to Warnings and Cautions in This Manual	iv
General Warnings and Cautions	ix
UL® Cautions, Warnings, and Instructions	xii

Table of Contents

Revisions	xix
Contact Information	xx

Chapter 1: Getting Started

Introduction	1-2
Inverter Specifications	1-6
Introduction to Variable-Frequency Drives	1-14
Frequently Asked Questions	1-18

Chapter 2: Inverter Mounting and Installation

Orientation to Inverter Features	2-2
Basic System Description	2-5
Step-by-Step Basic Installation	2-6
Powerup Test	2-27
Using the Front Panel Keypad	2-29
Emergency Stop Function	2-37

Chapter 3: Configuring Drive Parameters

Choosing a Programming Device	3-2
Using Keypad Devices	3-3
“D” Group: Monitoring Functions	3-6
“F” Group: Main Profile Parameters	3-9
“A” Group: Standard Functions	3-10
“B” Group: Fine-Tuning Functions	3-30
“C” Group: Intelligent Terminal Functions	3-50
“H” Group: Motor Constants Functions	3-66
“P” Group: Expansion Card Functions	3-69
“U” Group: User-selectable Menu Functions	3-74
Programming Error Codes	3-75

Chapter 4: Operations and Monitoring

Introduction	4-2
Optional Controlled Decel and Alarm at Power Loss	4-4
Connecting to PLCs and Other Devices	4-7
Using Intelligent Input Terminals	4-13
Using Intelligent Output Terminals	4-43
Analog Input Operation	4-63
Analog Output Operation	4-66
Setting Motor Constants for Vector Control	4-69
PID Loop Operation	4-75
Configuring the Inverter for Multiple Motors	4-76

Chapter 5: Inverter System Accessories

<u>Introduction</u>	5-2
<u>Component Descriptions</u>	5-3
<u>Dynamic Braking</u>	5-6

Chapter 6: Troubleshooting and Maintenance

<u>Troubleshooting</u>	6-2
<u>Monitoring Trip Events, History, & Conditions</u>	6-5
<u>Restoring Factory Default Settings</u>	6-16
<u>Maintenance and Inspection</u>	6-17
<u>Warranty</u>	6-29

Appendix A: Glossary and Bibliography

<u>Glossary</u>	A-2
<u>Bibliography</u>	A-6

Appendix B: Serial Communications

<u>Introduction</u>	B-2
<u>ASCII Mode Communications</u>	B-5
<u>Communications Reference Information</u>	B-18
<u>ModBus Mode Communications</u>	B-21
<u>ModBus Data Listing</u>	B-33

Appendix C: Drive Parameter Settings Tables

<u>Introduction</u>	C-2
<u>Parameter Settings for Keypad Entry</u>	C-2

Appendix D: CE-EMC Installation Guidelines

<u>CE-EMC Installation Guidelines</u>	D-2
<u>Precautions for EMC, Models SJ700-004 to -1500</u>	D-4
<u>Precautions for EMC, Models SJ700-1850 to -4000</u>	D-5

Index

Revisions

Revision History Table

No.	Revision Comments	Date of Issue	Operation Manual No.
	Initial release of manual NB206X	August 2008	NB206X
A	Add new inverter models from -004xxx to 037xxx, and models -750Hxx to -400Hxx Numerous additions and corrections throughout manual	October 2009	NB206XA

Contact Information

Hitachi America, Ltd.
Industrial Sales Division
50 Prospect Avenue
Tarrytown, NY 10591
U.S.A.
Phone: +1-914-631-0600
Fax: +1-914-631-3672
Web site: www.hitachi-america.us/inverters

Hitachi Europe GmbH
Am Seestern 18
D-40547 Düsseldorf
Germany
Phone: +49-211-5283-0
Fax: +49-211-5283-649
Web site: www.hitachi-ds.com/en/product/inv/

Hitachi Asia Ltd.
16 Collyer Quay
#20-00 Hitachi Tower, Singapore 049318
Singapore
Phone: +65-538-6511
Fax: +65-538-9011

Hitachi Asia (Hong Kong) Ltd.
7th Floor, North Tower
World Finance Centre, Harbour City
Canton Road, Tsimshatsui, Kowloon
Hong Kong
Phone: +852-2735-9218
Fax: +852-2735-6793

Hitachi Australia Ltd.
Level 3, 82 Waterloo Road
North Ryde, N.S.W. 2113
Australia
Phone: +61-2-9888-4100
Fax: +61-2-9888-4188

Hitachi Industrial Equipment Systems Co., Ltd.
AKS Building, 3, Kanda Neribeicho
Chiyoda-ku, Tokyo, 101-0022
Japan
Phone: +81-3-4345-6910
Fax: +81-3-4345-6067

Hitachi Industrial Equipment Systems Co, Ltd.
Narashino Division
1-1, Higashi-Narashino 7-chome
Narashino-shi, Chiba 275-8611
Japan
Phone: +81-47-474-9921
Fax: +81-47-476-9517
Web site: www.hitachi-ies.co.jp/english/



NOTE: To receive technical support for the Hitachi inverter you purchased, contact the Hitachi inverter dealer from whom you purchased the unit, or the sales office or factory contact listed above. Please be prepared to provide the following inverter nameplate information:

1. Model
2. Date of purchase
3. Manufacturing number (MFG No.)
4. Symptoms of any inverter problem

If any inverter nameplate information is illegible, please provide your Hitachi contact with any other legible nameplate items. To reduce unpredictable downtime, we recommend that you stock a spare inverter.

Getting Started



1

In This Chapter....

page

- [Introduction](#) [2](#)
- [Inverter Specifications](#)..... [6](#)
- [Introduction to Variable-Frequency Drives](#)..... [14](#)
- [Frequently Asked Questions](#)..... [18](#)

Introduction

Main Features

Congratulations on your purchase of an SJ700 Series Hitachi inverter! This inverter drive features state-of-the-art circuitry and components to provide high performance. The housing footprint is exceptionally small, given the size of the corresponding motor. The Hitachi SJ700 product line includes more than twenty inverter models to cover motor sizes from 1/2 horsepower to 500 horsepower, in either 230 VAC or 480 VAC power input versions. The main features are:

- 200V Class and 400V Class inverters
- U.S. or European version available
- Sensorless vector control
- Regenerative braking circuit
- Different operator keypads available for RUN/STOP control and setting parameters
- Built-in RS-422 communications interface to allow configuration from a PC and for field bus external modules
- Sixteen programmable speed levels
- Motor constants are programmable, or may be set via auto-tuning
- PID control adjusts motor speed automatically to maintain a process variable value

The design of Hitachi inverters overcomes many of the traditional trade-offs between speed, torque and efficiency. The performance characteristics are:

- High starting torque of 150% rating or greater
- Continuous operation at 100% rated torque within a 1:10 speed range (6/60 Hz / 5/50 Hz) without motor derating
- Models from 0.4–22kW (1/2 to 30hp) have built-in dynamic braking circuits
- Models from 0.4–11kW (1/2 to 15hp) have optional built-in dynamic braking resistor
- Cooling fan has ON/OFF selection to provide longer life

A full line of accessories from Hitachi is available to complete your motor control application. These include:

- Digital remote operator keypad
- Expansion card for sensor feedback
- Braking resistors
- Radio noise filters
- Built-in CE compliance filters
- Additional factory I/O network interface cards (to be announced)



Model SJ700-110HFUF2 (U.S. version)



*Model SJ700-037HFEF2
(European version)*



Expansion Card - Encoder Input

Digital Operator Interface Components

The SJ7002 Series inverters have a detachable keypad (called a digital operator) on the front panel of the housing. The particular keypad that comes with the inverter depends on the country or continent corresponding to the particular model number. The standard digital operators occupy just part of the keypad recess in the panel. Therefore, the inverter comes with a snap-in panel filler plate that mounts below the keypad as shown.

These detachable keypads can be mounted in a NEMA cabinet panel door cut-out, for example. Threaded metal inserts on the rear of the keypads facilitate this external mounting configuration. A short cable then connects the keypad unit to the connector in the inverter keypad recess. See Chapter 3 for information on how to install and use these keypads and cables.



Digital Operator OPE-SRE
standard for -LFU and -HFU models



Digital Operator OPE-S
standard for -HFE models

The digital operator / copy unit is optional, and occupies the entire keypad recess when mounted. It has the additional capability of reading (uploading) the parameter settings in the inverter into its memory. Then you can install the copy unit on another inverter and write (download) the parameter settings into that inverter. OEMs will find this unit particularly useful, as one can use a single copy unit to transfer parameter settings from one inverter to many.

Other digital operator interfaces may be available from your Hitachi distributor for particular industries or international markets. Contact your Hitachi distributor for further details.



Optional Digital Operator / Copy Unit
SRW-0EX

Removable Components

The SJ7002 Series inverters are designed for long life and ease of service. Several components are removable as shown below, aiding installation or parts replacement. Details on how and when to remove these parts are in the referenced chapters.



Fan Unit
(See Chapter 6 for servicing)



Digital Operator and Panel Filler Plate
(See Chapter 3 for instructions)



Auxiliary fan (on some models)



Control Signal Terminal Block
(See Chapter 4 for wiring)



Capacitor Bank for DC Link
(See Chapter 6 for servicing)



Cable entry/exit plate
(See Chapter 2 for instructions)

Specifications Label and Agency Approvals

The Hitachi SJ7002 inverters have product specifications labels located on the front and the right side of the housing, as shown below. The director reactor filters also have a product label. Be sure to verify that the specifications on the labels match your power source, motor, and application safety requirements.

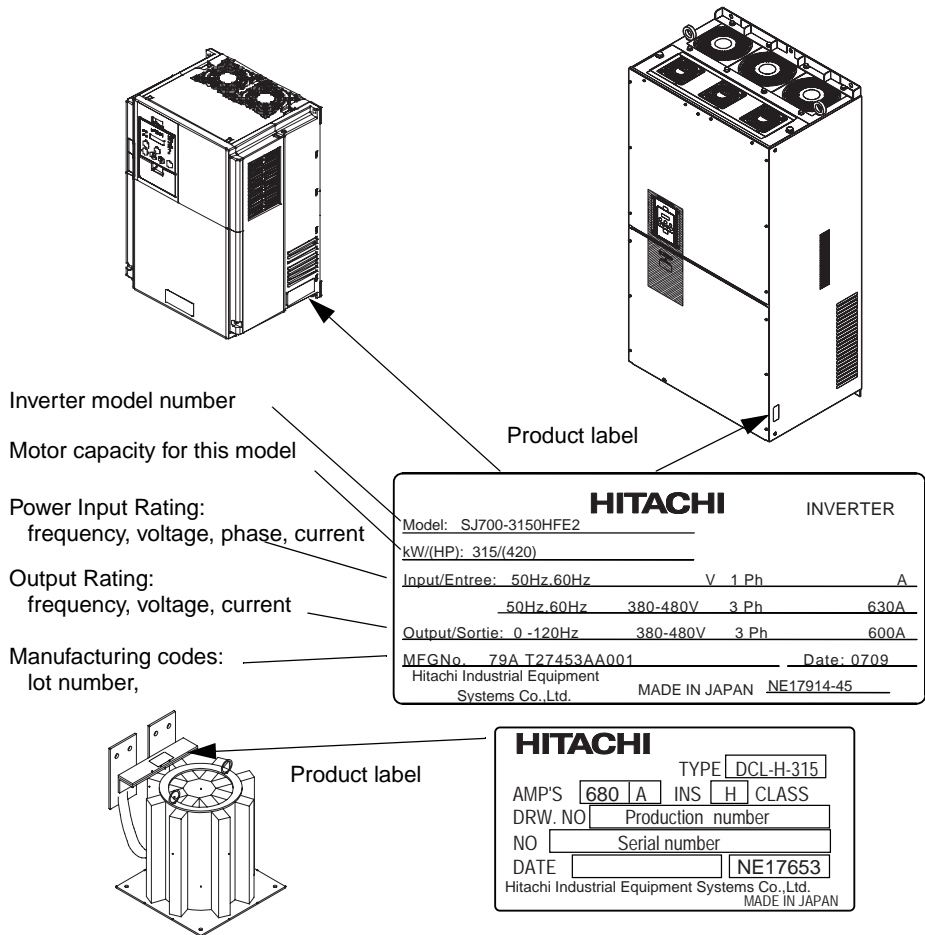

Model Number Convention

The model number for a specific inverter contains useful information about its operating characteristics. Refer to the model number legend below:

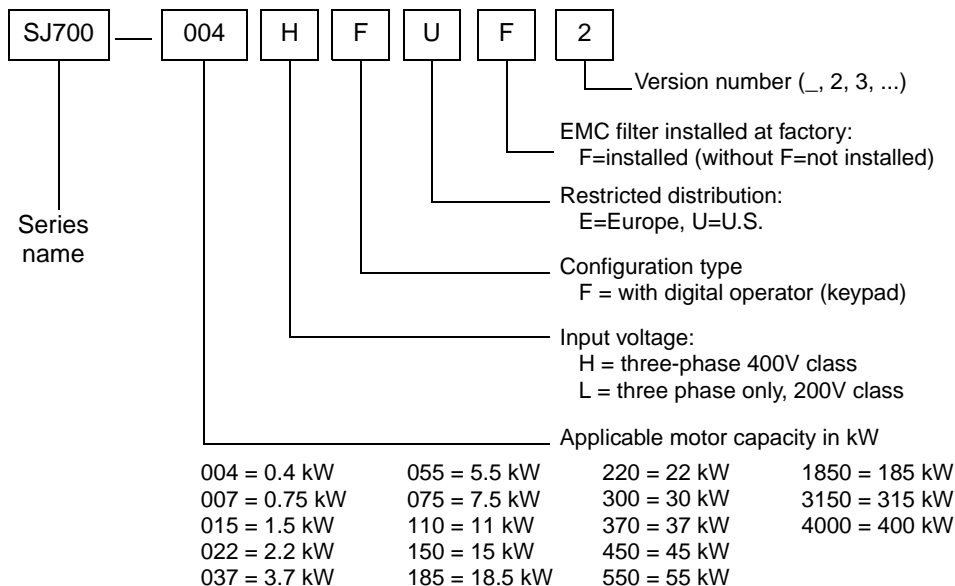

Inverter Specifications

Tables for 200V class inverters

Note that [“General Specifications” on page 1-10](#) covers all SJ7002 inverters, followed by footnotes for all specifications tables. The 200V models from -004 to -220LFU2 (0.5 to 30 HP) include internal dynamic braking units (see [“Dynamic Braking” on page 5-6](#)).

Item		200V Class Specifications				
SJ7002, 200V models, U.S. version		004LFUF2	007LFUF2	015LFUF2	022LFUF2	037LFUF2
Applicable motor size, 4-pole *2	HP	0.5	1	2	3	5
	kW	0.4	0.75	1.5	2.2	3.7
Rated capacity, kVA, 200V / 240V		1.0 / 1.2	1.7 / 2.0	2.5 / 3.1	3.6 / 4.3	5.7 / 6.8
Rated input voltage		3-phase: 200 to 240V +10%/-15%, 50/60 Hz ±5%				
Rated input current (A)		3.3	5.5	8.3	12	18
Rated output voltage *3		3-phase (3-wire) 200 to 240V (corresponding to input voltage)				
Rated output current (A)		3	5	7.5	10.5	16.5
Overload capacity, output current (A)		150% for 60 sec., 200% for 3 sec.				
Efficiency at 100% rated output, %		85.1	89.5	92.3	93.2	94.0
Watt loss, approximate (W)	at 70% output	64	76	102	127	179
	at 100% output	70	88	125	160	235
Dynamic braking approx. % torque, short time stop *7	internal chopper	20	20	20	20	20
	with external res.	>150	>150	>150	>150	110
Min. external braking resistance	Ω	50	50	35	35	35
DC braking		Variable operating frequency, time, and braking force				
Electrical filtering		Built-in EMC filter and built-in zero-phase reactor				
Weight	kg / lb	3.5 / 7.7	3.5 / 7.7	3.5 / 7.7	3.5 / 7.7	3.5 / 7.7

Item		200V Class Specifications					
SJ7002, 200V models, U.S. version		055LFUF2	075LFUF2	110LFUF2	150LFUF2	185LFUF2	220LFU2
Applicable motor size, 4-pole *2	HP	7.5	10	15	20	25	30
	kW	5.5	7.5	11	15	18.5	22
Rated capacity, kVA, 200V / 240V		8.3 / 9.9	11.0 / 13.3	15.9 / 19.1	22.1 / 26.6	26.3 / 31.5	32.9 / 39.4
Rated input voltage		3-phase: 200 to 240V +10%/-15%, 50/60 Hz ±5%					
Rated input current (A)		26	35	51	70	84	105
Rated output voltage *3		3-phase (3-wire) 200 to 240V (corresponding to input voltage)					
Rated output current (A)		24	32	46	64	76	95
Overload capacity, output current (A)		150% for 60 sec., 200% for 3 sec.					
Efficiency at 100% rated output, %		94.4	94.6	94.8	94.9	95.0	95.0
Watt loss, approximate (W)	at 70% output	242	312	435	575	698	820
	at 100% output	325	425	600	800	975	1150
Dynamic braking approx. % torque, short time stop *7	internal chopper	20	20	10	10	10	10
	with external res.	140	>150	110	110	90	110
Min. external braking resistance	Ω	16	10	10	7.5	7.5	5
DC braking		Variable operating frequency, time, and braking force					
Electrical filtering		Built-in EMC filter and built-in zero-phase reactor					
Weight	kg / lb	6 / 13.2	6 / 13.2	6 / 13.2	14 / 30.8	14 / 30.8	14 / 30.8

Item		200V Class Specifications, continued			
SJ7002, 200V models, U.S. version		300LFU2	370LFU2	450LFU2	550LFU2
Applicable motor size *2	HP	40	50	60	75
	kW	30	37	45	55
Rated capacity, kVA, 200V / 240V		41.9 / 50.2	50.2 / 60.2	63.0 / 75.6	76.2 / 91.4
Rated input voltage		3-phase: 200 to 240V +10/-15%, 50/60 Hz ±5%			
Rated input current (A)		133	160	200	242
Rated output voltage *3		3-phase (3-wire) 200 to 240V (corresponding to input voltage)			
Rated output current (A)		121	145	182	220
Overload capacity, output current (A)		150% for 60 sec., 200% for 3 sec.			
Efficiency at 100% rated output, %		95.0	95.1	95.1	95.1
Watt loss, approximate (W)	at 70% output	1100	1345	1625	1975
	at 100% output	1550	1900	2300	2800
Dynamic braking approx. % torque, short time stop *7	w/o braking unit	10	10	10	10
	with braking unit	55-110%	45-90%	35-75%	30-60%
DC braking		Variable operating frequency, time, and braking force			
Electrical filtering		Built-in EMC filter and built-in zero-phase reactor			
Weight	kg / lb	22 / 48.4	30 / 66	30 / 66	43 / 94.6

Tables for 400V class inverters

Note that [“General Specifications” on page 1-10](#) covers all SJ7002 inverters, followed by footnotes for all specifications tables. The 400V models from -007 to -220HFU2 (7.5 to 30 HP) include internal dynamic braking units (see [“Dynamic Braking” on page 5-6](#)).

Item		400V Class Specifications				
SJ7002 inverters, 400V models	U.S. version	007HFUF2	015HFUF2	022HFUF2	040HFUF2	055HFUF2
	European ver.	007HFEF2	015HFEF2	022HFEF2	040HFEF2	055HFEF2
Applicable motor size *2	HP	1	2	3	5	7.5
	kW	0.75	1.5	2.2	4	5.5
Rated capacity, kVA, 400 / 480V		1.7 / 2.0	2.5 / 3.1	3.6 / 4.3	5.7 / 6.8	9.7 / 11.6
Rated input voltage		3-phase (3-wire) 380 to 480V +10/-15%, 50/60 Hz ±5%				
Rated input current (A)		2.8	4.2	5.8	9.9	13
Rated output voltage *3		3-phase (3-wire): 380 to 480V (corresponding to input voltage)				
Rated output current (A)		2.5	3.8	5.3	9.0	14
Overload capacity, output current (A)		150% for 60 sec., 200% for 3 sec.				
Efficiency at 100% rated output, %		89.5	92.3	93.2	94.0	94.4
Watt loss, approximate (W)	at 70% output	76	102	127	179	242
	at 100% output	88	125	160	235	325
Dynamic braking approx. % torque, short time stop *7	internal chopper	20	20	20	20	20
	with external res.	>150	>150	>150	>150	130
Min. external braking resistance	Ω	100	100	100	70	70
DC braking		Variable operating frequency, time, and braking force				
Electrical filtering		Built-in EMC filter and built-in zero-phase reactor				
Weight	kg / lb	3.5 / 7.7	3.5 / 7.7	3.5 / 7.7	3.5 / 7.7	6 / 13.2

Item		400V Class Specifications				
SJ7002 inverters, 400V models	U.S. version	075HFUF2	110HFUF2	150HFUF2	185HFUF2	220HFUF2
	European ver.	075HFUF2	110HFUF2	150HFUF2	185HFUF2	220HFUF2
Applicable motor size *2	HP	10	15	20	25	30
	kW	7.5	11	15	18.5	22
Rated capacity, kVA, 400 / 480V		11 / 13.3	15.9/19.1	22.1 / 26.6	26.3 / 31.5	33.2 / 39.9
Rated input voltage		3-phase (3-wire) 380 to 480V +10/-15%, 50/60 Hz ±5%				
Rated input current (A)		18	25	35	42	53
Rated output voltage *3		3-phase (3-wire): 380 to 480V (corresponding to input voltage)				
Rated output current (A)		16	23	32	38	48
Overload capacity, output current (A)		150% for 60 sec., 200% for 3 sec.				
Efficiency at 100% rated output, %		94.6	94.8	94.9	95.0	95.0
Watt loss, approximate (W)	at 70% output	312	435	575	698	820
	at 100% output	425	600	800	975	1150
Dynamic braking approx. % torque, short time stop *7	internal chopper	20	10	10	10	10
	with external res.	>150	130	140	140	110
Min. external braking resistance	Ω	35	35	24	24	20
DC braking		Variable operating frequency, time, and braking force				
Electrical filtering		Built-in EMC filter and built-in zero-phase reactor				
Weight	kg / lb	5 / 11	5 / 11	12 / 26.4	12 / 26.4	12 / 26.4

Item		400V Class Specifications				
SJ7002 inverters, 400V models	U.S. version	300HFU2	370HFU2	450HFU2	550HFU2	750HFU2
	European ver.	300HFU2	370HFU2	450HFU2	550HFU2	750HFU2
Applicable motor size *2	HP	40	50	60	75	100
	kW	30	37	45	55	75
Rated capacity, kVA, 400 / 480V		40.1 / 48.2	51.9 / 62.3	62.3 / 74.8	76.2/91.4	103.2/ 123.8
Rated input voltage		3-phase (3-wire) 380 to 480V +10/-15%, 50/60 Hz ±5%				
Rated input current (A)		64	83	99	121	164
Rated output voltage *3		3-phase (3-wire): 380 to 480V (corresponding to input voltage)				
Rated output current (A)		58	75	90	110	149
Overload capacity, output current (A)		150% for 60 sec., 200% for 3 sec.				
Efficiency at 100% rated output, %		95.1	95.1	95.1	95.1	95.2
Watt loss, approximate (W)	at 70% output	1100	1345	1625	1975	2675
	at 100% output	1550	1900	2300	2800	3800
Dynamic braking approx. % torque, short time stop *7	w/o braking unit	10%	10%	10%	10%	8%
	with braking unit	Refer to separate DB Unit instruction manual or contact your Hitachi distributor				
DC braking		Variable operating frequency, time, and braking force				
Electrical filtering		Built-in EMC filter and built-in zero-phase reactor				
Weight	kg / lb	22 / 48.4	30 / 66	30 / 66	50 / 110	55 / 121

The 400V models from –1850 to –4000HFU2/HFE2 (250 to 525 HP) include a DC reactor and ferrite core.

Item		400V Class Specifications					
SJ7002 inverters, 400V models	U.S. version	900HFU2	1100HFU2	1500HFU2	1850HFU2	3150HFU2	4000HFU2
	European ver.	9000HFE2	1100HFE2	1320HFE2	1850HFE2	3150HFE2	4000HFE2
Applicable motor size *2	HP	125	150	200	250	425	525
	kW	90	110	150	185	315	400
Rated capacity, kVA, 400 / 480V		121.9/146.3	150.3/180.4	180.1/216.1	256 / 308	416 / 499	554 / 665
Rated input voltage		3-phase (3-wire) 380 to 480V +10/-15%, 50/60 Hz ±5%					
Rated input current (A)		194	239	286	389	630	840
Rated output voltage *3		3-phase (3-wire): 380 to 480V (corresponding to input voltage)					
Rated output current (A)		176	217	260	370	600	800
Overload capacity, output current (A)		50% for 60 sec., 200% for 0.5 sec.			50% for 60 sec., 180% for 0.5 sec.		
Inv. efficiency at 100% rated output, %		95.2	95.2	95.2	96.5	96.2	96.3
Inverter Watt loss, approximate (W)	at 70% output	3375	3900	4670	4700	8000	10500
	at 100% output	4800	5550	6650	6700	11500	15000
DCL efficiency at 100% rated output, %		—	—	—	99.9	99.9	99.9
DCL Watt loss, approximate (kW)	at 70% output	—	—	—	0.1	0.1	0.1
	at 100% output	—	—	—	0.2	0.2	0.2
Dynamic braking approx. % torque, short time stop *7	w/o braking unit	8%	8%	8%	10%	10%	10%
	with braking unit	Refer to separate DB Unit instruction manual or contact your Hitachi distributor					
DC braking		Variable operating frequency, time, and braking force					
Electrical filtering		Built-in EMC filter and zero-phase reactor			External DC reactor and ferrite core		
Weight	kg / lb	55 / 121	55 / 121	70 / 54	140 / 308	210 / 463	360 / 792

Footnotes for the preceding tables and the table that follows:

Note 1: The protection method conforms to JEM 1030.

Note 2: The applicable motor refers to Hitachi standard 3-phase motor (4-pole). When using other motors, care must be taken to prevent the rated motor current (50/60 Hz) from exceeding the rated output current of the inverter.

Note 3: The output voltage decreases as the main supply voltage decreases (except when using the AVR function). In any case, the output voltage cannot exceed the input power supply voltage.

Note 4: To operate the motor beyond 50/60 Hz, consult the motor manufacturer for the maximum allowable rotation speed.

Note 5: When SLV is selected, please set the carrier frequency higher than 2.1 kHz.

Note 6: At the rated voltage when using a Hitachi standard 3-phase, 4-pole motor (when selecting sensorless vector control—SLV).

Note 7: The braking torque via capacitive feedback is the average deceleration torque at the shortest deceleration (stopping from 50/60 Hz as indicated). It is not continuous regenerative braking torque. The average decel torque varies with motor loss. This value decreases when operating beyond 50 Hz. If a large regenerative torque is required, the optional regenerative braking resistor should be used.

Note 8: The frequency command will equal the maximum frequency at 9.8V for input voltage 0 to 10 VDC, or at 19.6 mA for input current 4 to 20 mA. If this characteristic is not satisfactory for your application, contact your Hitachi sales representative.

Note 9: The storage temperature refers to the short-term temperature during transport.

Note 10: Conforms to the test method specified in JIS C0050 (1999). For the model types excluded in the standard specifications, contact your Hitachi sales representative.

Note 11: NEMA 1 applies up to 22kW. An optional wire-entry conduit box is required for 0.4kW to 55kW models to meet NEMA 1 rating.

General Specifications

The following table (continued on next page) applies to all SJ7002 inverter models.

Item		General Specifications	
Protective enclosure *1, *11		IP20 (NEMA 1); models -750xFU2 to -4000xFU2 is IP00	
Control method		Line-to-line sine wave pulse-width modulation (PWM) control	
Output frequency range *4		0.1 to 400 Hz	
Frequency accuracy		Digital command: $\pm 0.01\%$ of the maximum frequency Analog command: $\pm 0.2\%$ (at 25°C $\pm 10^\circ\text{C}$)	
Frequency setting resolution		Digital: ± 0.01 Hz; Analog: (max. frequency)/4000, [O] terminal: 12-bit 0 to 10V; [OI] terminal: 12-bit, 4-20mA; [O2] terminal: 12-bit -10 to +10V	
Volt./Freq. characteristic *5		V/F optionally variable (30 to 400Hz base frequency), V/F control (constant torque, reduced torque), sensorless vector control, 0-Hz-range sensorless vector control	
Speed fluctuation		$\pm 0.5\%$ (sensorless vector control or 0-Hz range sensorless vector control)	
Acceleration/deceleration time		0.01 to 3600 sec., (linear curve profiles, accel./decel. selection), two-stage accel./decel.	
Starting Torque *6		200% at 0.3 Hz (SLV or 0Hz-range SLV), 150% at 0 Hz-range SLV, with motor one frame size down) For -750Hxx to -1500Hxx: 180% at 0.3Hz 150% at 0 Hz range with feedback board (with 0Hz-range sensorless vector control or with motor one frame size down) For -750Hxx to -1500Hxx: 130% at 0.3Hz	
Carrier frequency range		Models -004xFU2 to -550xFU2: 0.5 to 15.0 kHz; Models -750xFU2 to -1500xFU2: 0.5 to 10.0 kHz; Models -1850HFU2 to -4000HFU2: 0.5 to 3.0 kHz	
DC braking		Performs at start under set frequency at declaration, via an external input (braking force, time, and operating frequency)	
Overload capacity (output current)		150% for 60 seconds, 200% (180% for 75kW / 100HP and larger) for 0.5 seconds	
Input signal	Freq. setting	Operator keypad	Up and Down keys / Value settings
		Potentiometer	Analog setting via potentiometer on operator keypad
		External signal *8	0 to 10 VDC and -10 to +10 VDC (input impedance 10k Ohms), 4 to 20 mA (input impedance 250 Ohms), Potentiometer (1k to 2k Ohms, 2W)
		Serial port	RS485 interface
	FW/RV Run	Operator panel	Run key / Stop key (change FW/RV by function command)
		External signal	FW Run/Stop (NO contact), RV set by terminal assignment (NC/NO), 3-wire input available
		Serial port	RS485 interface
	Intelligent Input terminals (assign eight functions to terminals)	RV (reverse run/stop), CF1~CF4 (multi-speed select), JG (jogging), DB (external DC braking), SET (set 2nd motor data), 2CH (2-stage accel./decel.), FRS (free-run stop), EXT (external trip), USP (unattended start protection), CS (commercial power source), SFT (software lock), AT (analog input voltage/current select), SET3 (set 3rd motor data), RS (reset inverter), STA (start, 3-wire interface), STP (stop, 3-wire interface), F/R (FW/RV 3-wire interface), PID (PID ON/OFF), PIDC (PID reset), CAS (control gain setting), UP (remote control Up function, motorized speed pot.), DWN (remote control Down function, motorized speed pot.), UDC (remote control data clearing), OPE (Operator control), SF1-SF7 (Multispeed bits 0-7), OLR (Overload limit change), TL (torque limit enable), TRQ1 (torque limit selection bit 1, LSB), TRQ2 (torque limit selection bit 2, MSB), PPI (Proportional / Proportional/Integral mode selection), BOK (Brake confirmation signal), ORT (Orientation - home search), LAC (LAC: LAD cancel), PCLR (Position deviation reset), STAT (pulse train position command input enable), ADD (trigger for frequency addition), F-TM (forcible-terminal operation), ATR (permission of torque command input), KHC (cumulative power clearance), SON (servo ON), FOC (pre-excitation), MI1 (general-purpose input 1), MI2 (general-purpose input 2), MI3 (general-purpose input 3), MI4 (general-purpose input 4), MI5 (general-purpose input 5), MI6 (general-purpose input 6), MI7 (general-purpose input 7), MI8 (general-purpose input 8), AHD (analog command holding), NO (not selected)	
	Thermistor input	One terminal (PTC characteristics)	

Item		General Specifications
Output signal	Intelligent Output terminals (assign six functions to five open collector outputs and one relay NO-NC contact)	RUN (run signal), FA1 (Frequency arrival type 1 – constant speed), FA2 (Frequency arrival type 2 – over-frequency), OL (overload advance notice signal 1), OD (Output deviation for PID control), AL (alarm signal), FA3 (Frequency arrival type 3 – at-frequency), OTQ (over-torque signal), IP (Instantaneous power failure signal), UV (Under-voltage signal), TRQ (In torque limit), RNT (Run time over), ONT (Power-ON time over), THM (thermal alarm), BRK (Brake release signal), BER (Brake error signal), ZS (Zero speed detect), DSE (speed deviation maximum), POK (Positioning completion), FA4 (Frequency arrival type 4 – over-frequency 2), FA5 (Frequency arrival type 5 – at-frequency 2), OL2 (Overload notice advance signal 2), FBV (PID feedback comparison), Ndc (communication line disconnection), LOG1 (logical operation result 1), LOG2 (logical operation result 2), LOG3 (logical operation result 3), LOG4 (logical operation result 4), LOG5 (logical operation result 5), LOG6 (logical operation result 6), WAC (capacitor life warning), WAF (cooling fan speed drop), FR (starting contact signal), OHF (heat sink overheat warning), LOC (low-current indication signal), MO1 (general-purpose output 1), MO2 (general-purpose output 2), MO3 (general-purpose output 3), MO4 (general-purpose output 4), MO5 (general-purpose output 5), MO6 (general-purpose output 6), IRDY (inverter ready), FWR (forward rotation signal), RVR (reverse rotation signal), MJA (major failure signal), Terminals 11-13 or 11-14 automatically configured as AC0-AC2 or AC0-AC3 per alarm code output selection
	Intelligent monitor output terminals	Analog voltage monitor, analog current monitor (8-bit resolution), and PWM output, on terminals [AM], [AMI], [FM]
Display monitor		Output frequency, output current, motor torque, scaled value of output frequency, trip history, I/O terminal condition, electrical power and other parameters
Other user-settable parameters		V/F free-setting (up to 7 points), freq. upper/lower limit, freq. jump, accel/decel curve selection, manual torque boost value and freq. adjustment, energy saving operation, analog meter tuning, start frequency, carrier frequency, electronic thermal protection level, external frequency output zero/span reference, external frequency input bias start/end, analog input selection, retry after trip, restart after instantaneous power failure, various signal outputs, reduced voltage start, overload restriction, default value setting (US, Europe, Japan), automatic deceleration at power failure, AVR function, fuzzy accel/decel, auto-tuning (on-line/off-line), high-torque multi-motor operation (sensor-less vector control of two motors by one inverter)
Protective functions		Over-current, overload, braking resistor overload, over voltage, EEPROM error, under-voltage error, CT (current transformer) error, CPU error, external trip, USP error, ground fault, input over voltage, instantaneous power failure, expansion card 1 error, expansion card 2 error, inverter thermal trip, phase failure detection, IGBT error, thermistor error
Environment	Temperature (*9)	Operating (ambient): -10 to 50°C / Storage: -20 to 65°C
	Humidity	20 to 90% relative humidity (non-condensing)
	Vibration *10	Models SJ700-004xxx to 220xxx: 5.9 m/s ² (0.6G), 10 to 55 Hz Models SJ700-300xx to 1500xxx: 2.94 m/s ² (0.3G), 10 to 55 Hz Models SJ700-3150xx to 4000xxx: 1.96 m/s ² (0.2G), 10 to 55 Hz
	Location	Altitude 1,000 m or less, indoors (no corrosive gasses or dust)
Coating color		Gray
Accessories	Feedback expansion card	SJ-FB (vector control loop speed sensor)
	Digital input exp. card	SJ-DG (4-digit BCD / 16-bit binary)
	DeviceNet expansion card	Option to support the open-network DeviceNet function
	LonWorks expansion card	Option to support the open-network LonWorks function
	Profibus-DP option	Option to support the open-network Profibus-DP function
	Other optional accessories	EMI filter, AC reactor, DC reactor, radio noise filter, braking resistors, braking units, LCR filter, communication cables
Operator input devices		OPE-SRE (4-digit LED with potentiometer) / OPE-S (4-digit LED w/o potentiometer), Optional: OPE-SR (4-digit LED with potentiometer, Japanese/English overlay), SRW-0EX Multilingual operator with copy function (English, Spanish, French, German, Italian, and Portuguese)

Signal RatingsDetailed ratings are in [“Specifications of Control and Logic Connections” on page 4-9.](#)

Signal / Contact	Ratings
Built-in power for inputs	24VDC supply, 100 mA maximum
Intelligent (programmable) logic inputs	27VDC maximum, 4.7k Ω input impedance
Intelligent (programmable) logic outputs	Open collector type, 50mA max. ON state current, 27 VDC maximum OFF state voltage
Thermistor input	Minimum thermistor power 100mW
PWM output	0 to 10VDC, 1.2 mA max., 50% duty cycle
Voltage analog output	0 to 10VDC, 2 mA max.
Current analog output	4-20 mA, nominal load impedance 250 Ω
Analog input, current	4 to 19.6 mA range, 20 mA nominal
Analog input, voltage unipolar	0 to 9.6 VDC range, 10VDC nominal, 12VDC max., input impedance 10 k Ω
Analog input, voltage bipolar	-9.6 to 9.6 VDC range, \pm 10VDC nominal, \pm 12VDC max., input impedance 10 k Ω
+10V analog reference	10VDC nominal, 10 mA maximum
Alarm relay, normally closed contacts	Maximum loads: 250VAC, 2A; 30VDC, 8A resistive load 250VAC, 0.2A; 30VDC, 0.6A inductive load Minimum loads: 100 VAC, 10mA; 5VDC, 100mA
Alarm relay, normally open contacts	250VAC, 1A; 30VDC 1A max. resistive load / 250VAC, 0.2A; 30VDC, 0.2A max. inductive load Min. loads: 100 VAC, 10mA; 5VDC, 100mA

DCL Filter Specifications

Direct reactor filters (DCL) are available for the Hitachi high-capacity SJ7002 inverters, models -1850HFU2 to -4000HFU2. The DCL specifications are in the following table.

Item	DCL Specifications		
DCL models, DCL-H-xxx	185	315	400
Rated current (A)	515.0	680	1042
Insulation class	Type H		
Weight kg / lb.	65	75	90

Carrier Frequency DeratingThe maximum carrier frequency F_c that provides full inverter rated output depends on the particular inverter model. However, you may operate an inverter at the maximum settable F_c with an output derating. Refer to the table below for the carrier frequency values and output deratings.

200V Class Inverters					
Capacity (kW)	Maximum F_c (kHz)	Derating at $F_c = 15$ kHz	Capacity (kW)	Maximum F_c (kHz)	Derating at $F_c = 15$ kHz
0.4	15	100%	15	12	95% (60.8A or less)
0.75	15	100%	18.5	10	90% (68.4A or less)
1.5	15	100%	22	7	70% (66.5A or less)
2.2	15	100%	30	5	80% (96.8A or less)
3.7 / 4.0	15	100%	37	10	75% (108.7A or less)
5.5	15	100%	45	5	70% (127.4A or less)
7.5	15	100%	55	5	70% (154.0A or less)
11	12	90% (41.4A or less)	—	—	—

400V Class Inverters					
Capacity (kW)	Maximum F _c (kHz)	Derating at Maximum Fc	Capacity (kW)	Maximum F _c (kHz)	Derating at Maximum Fc
0.75	15	100%	37	8	80% (60.0A or less)
1.5	15	100%	45	9	75% (68.2A or less)
2.2	15	100%	55	6	60% (67.2A or less)
3.7	15	100%	75	6	85% (126.7A or less)
5.5	15	100%	90	4	75% (132.0A or less)
7.5	15	100%	110	6	70% (151.9A or less)
11	15	100%	150	3	60% (156.0A or less)
15	14	95% (30.4A or less)	185	3	100%
18.5	10	90% (34.2A or less)	315	3	100%
22	6	75% (36.0A or less)	400	3	80% (640.0A or less)
30	10	75% (43.5A or less)	—	—	—



NOTE: When replacing an SJ300 inverter combined with LCR filter, please check the type code of LCR filter and consult for compatibility (75 to 132kW).

Introduction to Variable-Frequency Drives

The Purpose of Motor Speed Control for Industry

Hitachi inverters provide accurate speed control for 3-phase AC induction motors. You connect AC power to the inverter, and connect the inverter to the motor. Many applications can benefit from the use of variable-speed drives in several ways:

- Energy savings - HVAC
- Need to coordinate speed with an adjacent process - textiles and printing presses
- Need to control acceleration and deceleration (torque)
- Sensitive loads - elevators, food processing, pharmaceuticals

What is an Inverter?

The term *inverter* and *variable-frequency drive* are related and somewhat interchangeable. An electronic drive for an AC motor controls the motor's speed by *varying the frequency* of the power sent to the motor.

An inverter, in general, is a device that converts DC power to AC power. The figure below shows how the variable-frequency drive employs an internal inverter. The drive first converts incoming AC power to DC through a rectifier bridge, creating an internal DC bus voltage. Then the inverter circuit converts the DC back to AC again to power the motor. The special inverter can vary its output frequency and voltage according to the desired motor speed.

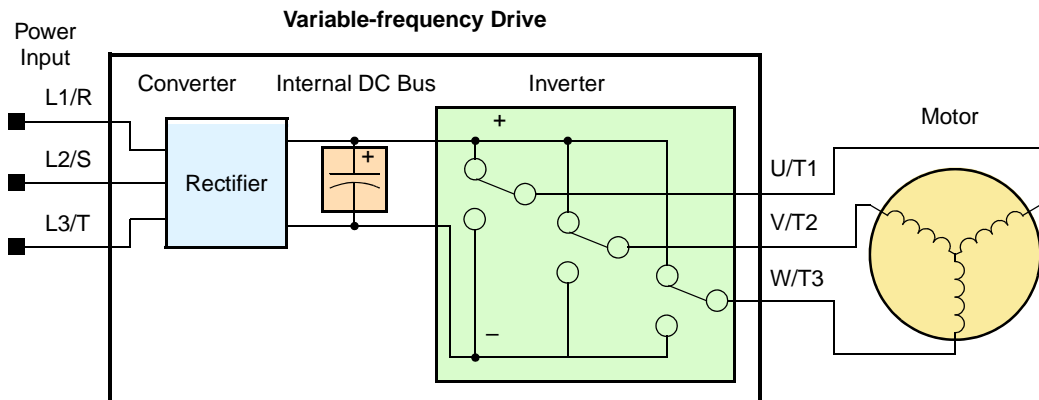

The simplified drawing of the inverter shows three double-throw switches. In Hitachi inverters, the switches are actually IGBTs (isolated gate bipolar transistors). Using a commutation algorithm, the microprocessor in the drive switches the IGBTs ON and OFF at a very high speed to create the desired output waveforms. The inductance of the motor windings helps smooth out the pulses.

Torque and Constant Volts/Hertz Operation

In the past, AC variable speed drives used an open loop (scalar) technique to control speed. The constant-volts-per-hertz operation maintains a constant ratio between the applied voltage and the applied frequency. With these conditions, AC induction motors inherently delivered constant torque across the operating speed range. For some applications, this scalar technique was adequate.

Today, with the advent of sophisticated microprocessors and digital signal processors (DSPs), it is possible to control the speed and torque of AC induction motors with unprecedented accuracy. The SJ7002 utilizes these devices to perform complex mathematical calculations required to achieve superior performance. The technique is referred to as *sensorless vector control*. It allows the drive to continuously monitor its output voltage and current, and their relationship to each other. From this it mathematically calculates two vector currents. One

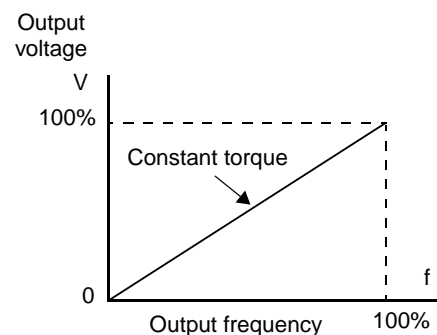

vector is related to motor flux current, and the other to motor torque current. The ability to separately control these two vectors is what allows the SJ7002 to deliver extraordinary low-speed performance and speed control accuracy.

Inverter Input and Three-Phase Power



The Hitachi SJ7002 Series of inverters includes two sub-groups: the 200V class and the 400V class inverters. The drives described in this manual may be used in either the United States or Europe, although the exact voltage level for commercial power may be slightly different from country to country. Accordingly, a 200V class inverter requires (nominal) 200 to 240VAC, and a 400V class inverter requires from 380 to 480VAC. All SJ7002 inverters require three-phase input power, whether 200V or 400V class.

TIP: If your application only has single phase power available, refer to the Hitachi SJ100 Series inverters. SJ100 inverters of 3HP or less can accept single phase input power.

The common terminology for single phase power is Line (L) and Neutral (N). Three-phase power connections are usually labeled Line 1 (L1), Line 2 (L2) and Line 3 (L3). In any case, the power source should include a ground connection. That ground connection will need to connect to the inverter chassis and to the motor frame (see [“Wire the Inverter Output to Motor” on page 2-26](#)).

Inverter Output to the Motor

The AC motor must be connected only to the inverter's output terminals. The output terminals are uniquely labeled (to differentiate them from the input terminals) with the designations U/T1, V/T2, and W/T3. This corresponds to typical motor lead connection designations T1, T2, and T3. It is often not necessary to connect a particular inverter output to a particular motor lead for a new application. The consequence of swapping any two of the three connections is the reversal of the motor direction. In applications where reversed rotation could cause equipment damage or personnel injury, be sure to verify direction of rotation before attempting full-speed operation. For safety to personnel, you must connect the motor chassis ground to the ground connection at the bottom of the inverter housing.

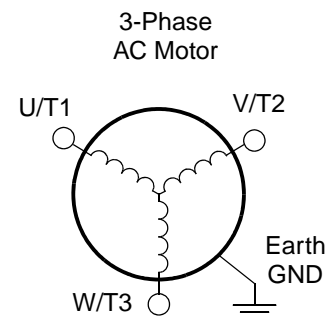

Notice the three connections to the motor do not include one marked “Neutral” or “Return.” The motor represents a balanced “Y” impedance to the inverter, so there is no need for a separate return. In other words, each of the three “Hot” connections serves also as a return for the other connections, because of their phase relationship.

The Hitachi inverter is a rugged and reliable device. The intention is for the inverter to assume the role of controlling power to the motor during all normal operations. Therefore, this manual instructs you not to switch OFF power to the inverter *while the motor is running* (unless it is an emergency stop). Also, do not install or use disconnect switches in the wiring from the inverter to the motor (except thermal disconnect). Of course, safety-related devices such as fuses must be in the design to break power during a malfunction, as required by NEC and local codes.

Intelligent Functions and Parameters

Much of this manual is devoted to describing how to use inverter functions and how to configure inverter parameters. The inverter is microprocessor-controlled, and has many independent functions. The microprocessor has an on-board EEPROM for parameter storage. The inverter's front panel keypad provides access to all functions and parameters, which you can access through other devices as well. The general name for all these devices is the *digital operator*, or *digital operator panel*. Chapter 2 will show you how to get a motor running, using a minimal set of function commands or configuring parameters.

The optional read/write programmer will let you read and write inverter EEPROM contents from the programmer. This feature is particularly useful for OEMs who need to duplicate a particular inverter's settings in many other inverters in assembly-line fashion.



Braking

In general, braking is a force that attempts to slow or stop motor rotation. So it is associated with motor deceleration, but may also occur even when the load attempts to drive the motor faster than the desired speed (overhauling). If you need the motor and load to decelerate quicker than their natural deceleration during coasting, we recommend installing a braking resistor. The dynamic braking unit (built into certain SJ7002 models) sends excess motor energy into a resistor to slow the motor and load (see [“Introduction” on page 5-2](#) and [“Dynamic Braking” on page 5-6](#) for more information). For loads that continuously overhaul the motor for extended periods of time, the SJ7002 may not be suitable (contact your Hitachi distributor).

The inverter parameters include acceleration and deceleration, which you can set to match the needs of the application. For a particular inverter, motor, and load, there will be a range of practically achievable accelerations and decelerations.

Velocity Profiles

The SJ7002 inverter is capable of sophisticated speed control. A graphical representation of that capability will help you understand and configure the associated parameters. This manual makes use of the velocity profile graph used in industry (shown at right). In the example, the acceleration is a ramp to a set speed, and the deceleration is a decline to a stop.

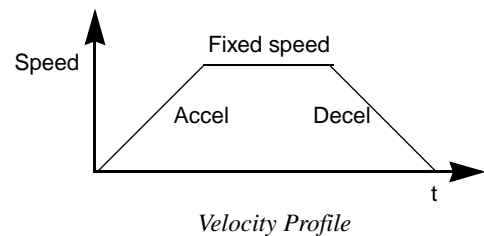

Acceleration and deceleration settings specify the time required to go from a stop to maximum frequency (or visa versa). The resulting slope (speed change divided by time) is the acceleration or deceleration. An increase in output frequency uses the acceleration slope, while a decrease uses the deceleration slope. The accel or decel time a particular speed change depends on the starting and ending frequencies. However, the slope is constant, corresponding to the full-scale accel or decel time setting.

For example, the full-scale acceleration setting (time) may be 10 seconds—the time required to go from 0 to 60 Hz.

The SJ7002 inverter can store up to 16 preset speeds. And, it can apply separate acceleration and deceleration transitions from any preset to any other preset speed. A multi-speed profile (shown at right) uses two or more preset speeds, which you can select via intelligent input terminals. This external control can apply any preset speed at any time. Alternatively, the selected speed is infinitely variable across the speed range. You can use the potentiometer control on the keypad for manual control. The drive accepts analog 0-10V signals and 4-20 mA control signals as well.

The inverter can drive the motor in either direction. Separate FW and RV commands select the direction of rotation. The motion profile example shows a forward motion followed by a reverse motion of shorter duration. The speed presets and analog signals control the magnitude of the speed, while the FW and RV commands determine the direction before the motion starts.

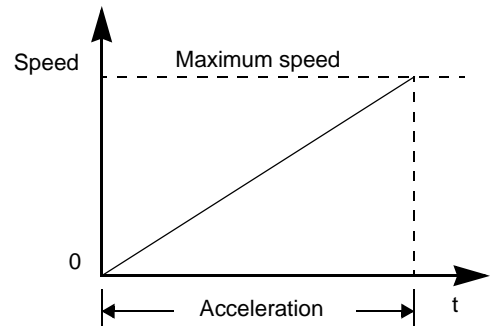

Acceleration (time) setting

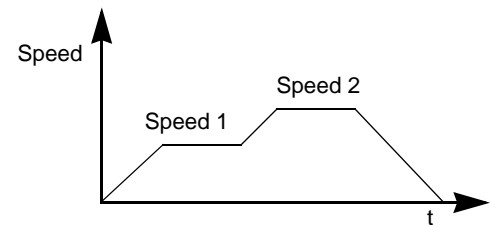

Multi-speed Profile

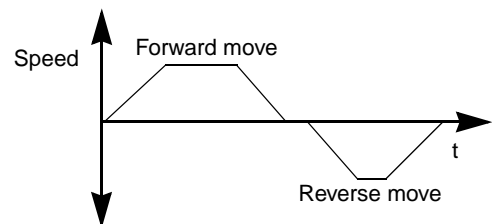

Bi-directional Profile



NOTE: The SJ7002 can move loads in both directions. However, it is not designed for use in servo-type applications that use a bipolar velocity signal that determines direction.

Frequently Asked Questions

- Q.** What is the main advantage in using an inverter to drive a motor, compared to alternative solutions?
- A.** An inverter can vary the motor speed with very little energy loss, unlike mechanical or hydraulic speed control solutions. The resulting energy savings can often pay for the inverter in a relatively short time.
- Q.** The term “inverter” is a little confusing, since we also use “drive” and “amplifier” to describe the electronic unit that controls a motor. What does “inverter” mean?
- A.** The terms are used somewhat interchangeably in industry. Nowadays, the terms *drive*, *variable-frequency drive*, *variable-speed drive*, and *inverter* are generally used to describe electronic, microprocessor-based motor speed controllers. In the past, *variable speed drive* also referred to various mechanical means to vary speed. *Amplifier* is a term almost exclusively used to describe drives for servo or stepper motors.
- Q.** Although the SJ7002 inverter is a variable speed drive, can I use it in a fixed-speed application?
- A.** Yes, sometimes an inverter can be used simply as a “soft-start” device, providing controlled acceleration and deceleration to a fixed speed. Other functions of the SJ7002 may be useful in such applications, as well. However, using a variable speed drive can benefit many types of industrial and commercial motor applications, by providing controlled acceleration and deceleration, high torque at low speeds, and energy savings over alternative solutions.
- Q.** Can I use an inverter and AC induction motor in a positioning application?
- A.** That depends on the required precision, and the slowest speed the motor must turn and still deliver torque. The SJ7002 inverter will deliver 200% rated torque while turning the motor at only 0.3 Hz. DO NOT use an inverter if you need the motor to stop and hold the load position without the aid of a mechanical brake (use a servo or stepper motion control system).
- Q.** Does the optional digital operator interface or the PC software (DOP Professional) provide features beyond what is available from the keypad on the unit?
- A.** Yes. However, note first that the same set of parameters and functions are equally accessible from either the unit’s keypad or from remote devices. The DOP Professional PC software lets you save or load inverter configurations to or from a disk file. And, the hand-held digital operator provides hard-wired terminals, a safety requirement for some installations.
- Q.** Why does the manual or other documentation use terminology such as “200V class” instead of naming the actual voltage, such as “230 VAC”?
- A.** A specific inverter model is set at the factory to work across a voltage range particular to the destination country for that model. The model specifications are on the label on the side of the inverter. A European 200V class inverter (“EU” marking) has different parameter settings than a USA 200V class inverter (“US” marking). The initialization procedure (see [“Restoring Factory Default Settings” on page 6–16](#)) can set up the inverter for European or US commercial voltage ranges.
- Q.** Why doesn’t the motor have a neutral connection as a return to the inverter?
- A.** The motor theoretically represents a “balanced Y” load if all three stator windings have the same impedance. The Y connection allows each of the three wires to alternately serve as input or return on alternate half-cycles.
- Q.** Does the motor need a chassis ground connection?
- A.** Yes, for several reasons. Most importantly, this provides protection in the event of a short in the motor that puts a hazardous voltage on its housing. Secondly, motors exhibit leakage currents that increase with aging. Lastly, a grounded chassis generally emits less electrical noise than an ungrounded one.



- Q.** What type of motor is compatible with the Hitachi inverters?
- A.** **Motor type** – It must be a three phase AC induction motor. Use an inverter-grade motor that has 800V insulation for 200V class inverters, or 1600V insulation for 400V class.
- Motor size** – In practice, it's better to find the right size motor for your application; then look for the inverter to match the motor.

NOTE: There may be other factors that will affect motor selection, including heat dissipation, motor operating speed profile, enclosure type, and cooling method.

- Q.** How many poles should the motor have?
- A.** Hitachi inverters can be configured to operate motors with 2, 4, 6, or 8 poles. The greater the number of poles, the slower the top motor speed will be, but it will have higher torque at the base speed.
- Q.** Will I be able to add dynamic (resistive) braking to my Hitachi SJ700z drive after the initial installation?
- A.** Yes. Models SJ700-004XXX through SJ700-220XXX have built-in dynamic braking units. You can add an external resistor to these models to improve braking performance. Models SJ700-300XXX through SJ700-4000XXX require you to add an external braking unit. The braking resistor connects to the external braking unit for those models. More information on dynamic braking is located in Chapter 5.
- Q.** How will I know if my application will require resistive braking?
- A.** For new applications, it may be difficult to tell before you actually test a motor/drive solution. In general, some applications can rely on system losses such as friction to serve as the decelerating force, or otherwise can tolerate a long decel time. These applications will not need dynamic braking. However, applications with a combination of a high-inertia load and a required short decel time will need dynamic braking. This is a physics question that may be answered either empirically or through extensive calculations.
- Q.** Several options related to electrical noise suppression are available for the Hitachi inverters. How can I know if my application will require any of these options?
- A.** The purpose of these noise filters is to reduce the inverter electrical noise so the operation of nearby electrical devices is not affected. Some applications are governed by particular regulatory agencies, and noise suppression is mandatory. In those cases, the inverter must have the corresponding noise filter installed. SJ700 models from -004XXX (0.4kW) to -1500XXX (150kW) have built-in EMC filters. Other applications may not need noise suppression, unless you notice electrical interference with the operation of other devices.
- Q.** The SJ700z features a PID loop feature. PID loops are usually associated with chemical processes, heating, or process industries in general. How could the PID loop feature be useful in my application?
- A.** You will need to determine the particular main variable in your application the motor affects. That is the process variable (PV) for the motor. Over time, a faster motor speed will cause a faster change in the PV than a slow motor speed will. By using the PID loop feature, the inverter commands the motor to run at the optimal speed required to maintain the PV at the desired value for current conditions. Using the PID loop feature will require an additional sensor and other wiring, and is considered an advanced application.



Inverter Mounting and Installation



2

In This Chapter....	page
— Orientation to Inverter Features	2
— Basic System Description	5
— Step-by-Step Basic Installation	6
— Powerup Test	27
— Using the Front Panel Keypad	29
— Emergency Stop Function	37

Orientation to Inverter Features

Unpacking and Inspection

Please take a few moments to unpack your new SJ700z inverter and perform these steps:

1. Look for any damage that may have occurred during shipping.
2. Verify the contents of the box include:
 - a. One SJ700z inverter
 - b. One Instruction Manual (supplied by printed book for –FU2/–FF2 models, supplied on CR-ROM for –FE2 models)
 - c. One SJ700z Quick Reference Guide
 - d. One packet of desiccant—discard (not for human consumption)
3. Inspect the specifications label on the front or side of the inverter. Make sure it matches the product part number you ordered.

Main Physical Features

The SJ700z Series inverters vary in size according to the current output rating and motor size for each model number. All feature the same basic keypad and connector interface for consistent ease of use. The inverter construction has a heat sink at the back of the housing. The fans enhance heat sink performance. Mounting holes are pre-drilled in the heat sink for your convenience. Never touch the heat sink during or just after operation; it can be very hot.

The electronics housing and front panel are built onto the front of the heat sink. The front panel has three levels of physical access designed for convenience and safety:

- **First-level access** – for basic use of inverter and editing parameters during powered operation (power is ON)
- **Second-level access** – for wiring the inverter power supply or motor (power is OFF)
- **Third-level access** – for accessing the expansion bay for adding/removing expansion boards (power is OFF)

1. **First-level Access** - View the unit just as it came from the box as shown. The OPE-SRE or OPE-S digital operator keypad comes installed in the inverter. The four-digit display can show a variety of performance parameters. LEDs indicate whether the display units are Hertz, Volts, Amperes, or kW. Other LEDs indicate Power (external), and Run/Stop Mode and Program/Monitor Mode status. Membrane keys Run and Stop/Reset, and a Min/Max frequency control knob (OPE-SRE only) control motor operation. These controls and indicators are usually the only ones needed after the inverter installation is complete.

The FUNC., \triangle , ∇ , and STR keys allow an operator to change the inverter's functions and parameter values, or to select the one monitored on the 4-digit display. Note that some parameters may not be edited if the inverter is in Run mode.



- 2. Second-level access** - First, ensure no power source of any kind is connected to the inverter. If power has been connected, wait 10 minutes after power-down and verify the Charge Lamp indicator is OFF to proceed. Then locate the two screws at the bottom corners of the main front panel. Use a Phillips screwdriver to loosen the screws and tilt the cover outward for removal. (The screws are retained in the cover.)



Notice the large power terminals at the bottom of the wiring area. The rubber grommets below the power terminals are for wire entry/exit to the power source and motor. Never operate the inverter with the front panel removed.

The control terminals connect logic or analog signals for control and monitoring of the inverter. The nearby alarm relay provides both normally-open and normally-closed logic for interface to an external alarm. The alarm circuit may carry hazardous live voltages even when the main power to the inverter is OFF. So, never directly touch any terminal or circuit component.

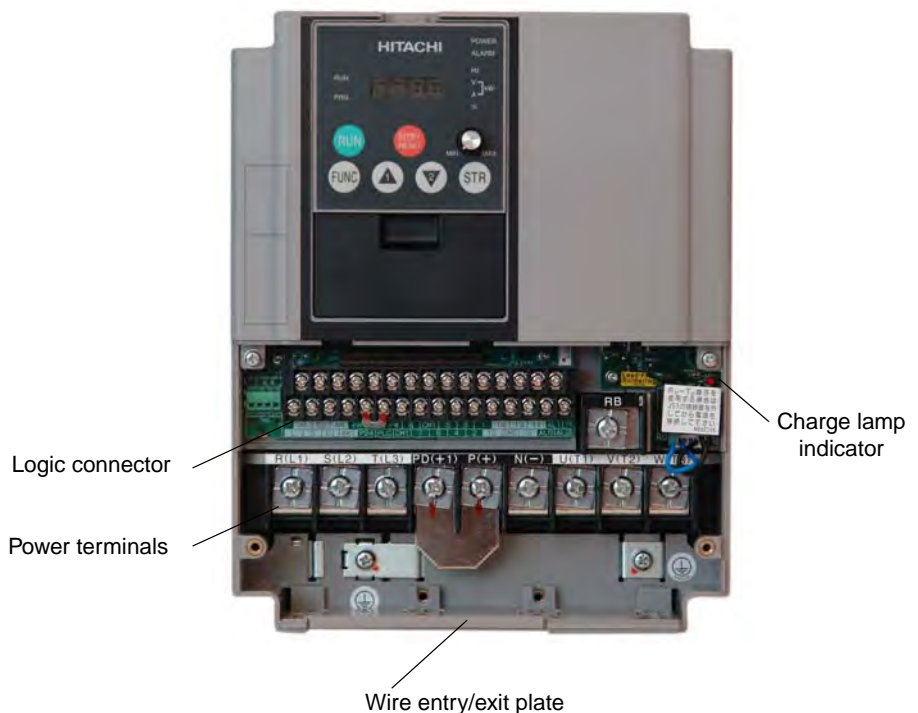

WARNING: Be sure to wait 10 minutes after powerdown and verify the charge lamp indicator is OFF to proceed. Otherwise there is the risk of electric shock.

3. Third-level access - The SJ7002 provides for field installation of interface circuits. These circuits are on expansion cards, to be installed in the expansion bay. To access the expansion bay, you will need to remove the upper front panel. Use the latch to release the digital operator (the panel filler plate may remain). Remove the two retention screws the bottom corners of the upper front panel. Lift up at the bottom, then disengage the two hinge latches at the top.



The expansion bay has two sites for adding expansion cards. Each card connects via the interface connector, and mounts using three standoff screw locations. Further details on accessories are in Chapter 5. You may also refer to the instruction manual that comes with each type of expansion card.

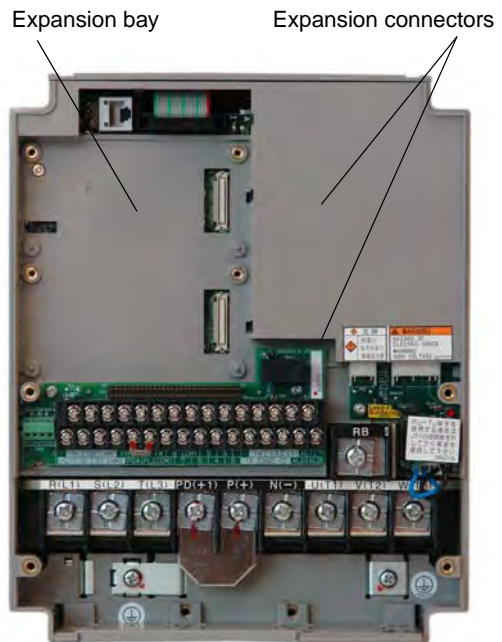

The following sections will describe the system design and guide you through a step-by-step installation process. After the section on wiring, this chapter will show how to use the front panel keys to access functions and edit parameters.

Basic System Description

A motor control system will obviously include a motor and inverter, as well as a breaker or fuses for safety. If you are connecting a motor to the inverter on a test bench just to get started, that's all you may need for now. But a system can also have a variety of additional components. Some can be for noise suppression, while others may enhance the inverter's braking performance. The figure and table below show a system with all the optional components you may need in your finished application.

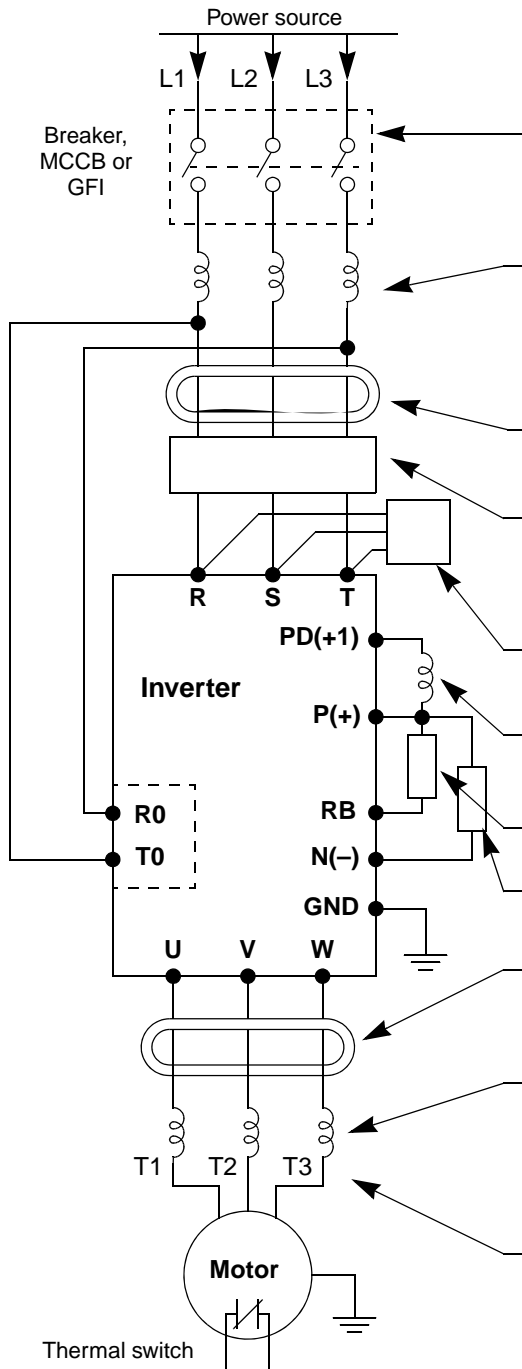

Name	Function
Breaker / disconnect	A molded-case circuit breaker (MCCB), ground fault interrupter breaker (GFI), or a fused disconnect device. NOTE: The installer must refer to the NEC and local codes to ensure safety and compliance.
Input side AC Reactor	This is useful in suppressing harmonics induced on the power supply lines, or when the main power voltage imbalance exceeds 3% (and power source capacity is more than 500 kVA), or to smooth out line fluctuations. It also improves the power factor.
Radio noise filter	Electrical noise interference may occur on nearby equipment such as a radio receiver. This magnetic choke filter helps reduce radiated noise (can also be used on output).
EMI filter (for CE applications, see Appendix D)	This filter reduces the conducted noise in the power supply wiring between the inverter and the power distribution system. Connect it to the inverter primary (input side).
Radio noise filter (use in non-CE applications)	This capacitive filter reduces radiated noise from the main power wires in the inverter input side.
DC link choke	The choke suppresses harmonics generated by the inverter. However, it will not protect the input diode bridge rectifier. A DCL reactor is required for models -185xxx to -4000xxx
Braking resistor	Braking components are useful for increasing the inverter's control torque for high duty-cycle (ON-OFF) applications, and improving the decelerating capability.
Braking unit	
Radio noise filter	Electrical noise interference may occur on nearby equipment such as a radio receiver. This magnetic choke filter helps reduce radiated noise (can also be used at input).
Output side AC reactor	This reactor reduces the vibrations in the motor caused by the inverter's switching waveform, by smoothing the waveform to approximate commercial power quality. It is also useful to reduce harmonics when wiring from the inverter to the motor is more than 10m in length.
LCR filter	Sine wave shaping filter for output side. The LCR filter is not required for models -1850xxx to -4000xxx.

Inverter Mounting and Installation



NOTE: Some components are required for regulatory agency compliance (see Chapter 5 and Appendix D).

Step-by-Step Basic Installation

This section will guide you through the following basic steps of installation:

1. Study the warnings associated with mounting the inverter.
2. Transport or lift the inverter (and DC reactor, if used) in a safe manner.
3. Select a suitable mounting location.



NOTE: If the installation is in an EU country, study the EMC installation guidelines in Appendix D.

4. Cover the inverter's top ventilation openings to prevent debris from falling inside.
5. Check the inverter mounting dimensions for footprint and mounting hole locations.
6. Study the caution and warning messages associated with wiring the inverter.
7. Connect wiring for the inverter power input.
8. Connect wiring to the motor.
9. Uncover the inverter's ventilation openings that were covered in Step 3.
10. Perform a powerup test.
11. Make observations and check your installation.

Step 1: Study the following caution messages associated with mounting the inverter. This is the time when mistakes are most likely to occur that will result in expensive rework, equipment damage, or personal injury.



Choosing a Mounting Location



CAUTION: Be sure to install the unit on flame-resistant material such as a steel plate. Otherwise, there is the danger of fire.



CAUTION: Be sure not to place any flammable materials near the inverter. Otherwise, there is the danger of fire.



CAUTION: Be sure not to let the foreign matter enter vent openings in the inverter housing, such as wire clippings, spatter from welding, metal shavings, dust, etc. Otherwise, there is the danger of fire.



CAUTION: Be sure to install the inverter in a place that can bear the weight according to the specifications in the text (Chapter 1, Specifications Tables). Otherwise, it may fall and cause injury to personnel.



CAUTION: Be sure to install the unit on a perpendicular wall that is not subject to vibration. Otherwise, it may fall and cause injury to personnel.



CAUTION: Be sure not to install or operate an inverter that is damaged or has missing parts. Otherwise, it may cause injury to personnel.



CAUTION: Be sure to install the inverter in a well-ventilated room that does not have direct exposure to sunlight, a tendency for high temperature, high humidity or dew condensation, high levels of dust, corrosive gas, explosive gas, inflammable gas, grinding-fluid mist, salt air, etc. Otherwise, there is the danger of fire.

The position and orientation of the inverter are very important. Install the inverter vertically and securely with screws or bolts on a surface that is free from vibrations and that can bear the inverter's weight. If the inverter is not installed vertically, its cooling performance may be degraded and trip events or inverter damage may result. If the inverter requires an external DC reactor, do not install the reactor directly under the inverter.

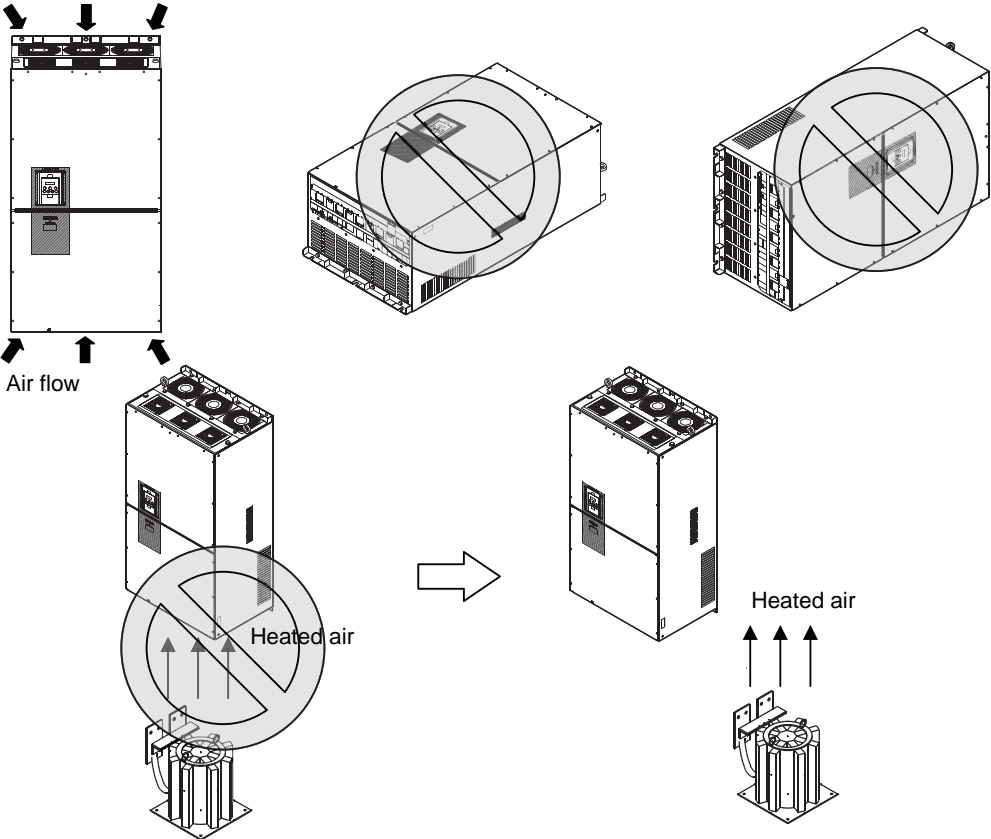

2

Transport or Lift in Safe Manner

SJ7002 Series inverter models -1850hFx2 to -4000hFx2 are very heavy. For example, the 315kW inverter weighs about 463 lbs. (210kg). Therefore, be careful when loading and transporting these inverters. Use the eyebolts on the inverter housing and frame to lift the inverter. The diagrams below show different lifting configurations to fit the orientations you may need.

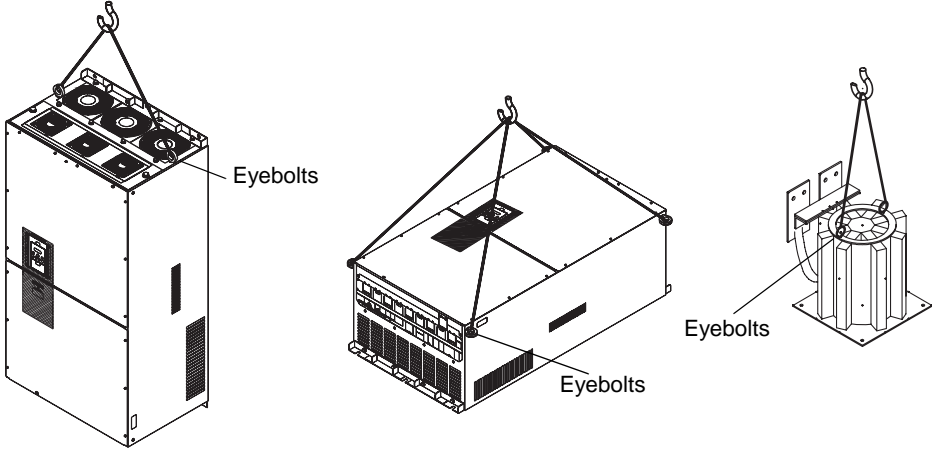

Upright inverter lifting: Use eyebolts at top of inverter Horizontal inverter lifting: Use eyebolts at front corners of inverter DC reactor lifting: Use bolts at top of frame

3

Ensure Adequate Ventilation

Step 2: To summarize the caution messages—you will need to find a solid, non-flammable, vertical surface that is in a relatively clean and dry environment. In order to ensure enough room for air circulation around the inverter to aid in cooling, maintain the specified clearance around the inverter specified in the diagram.

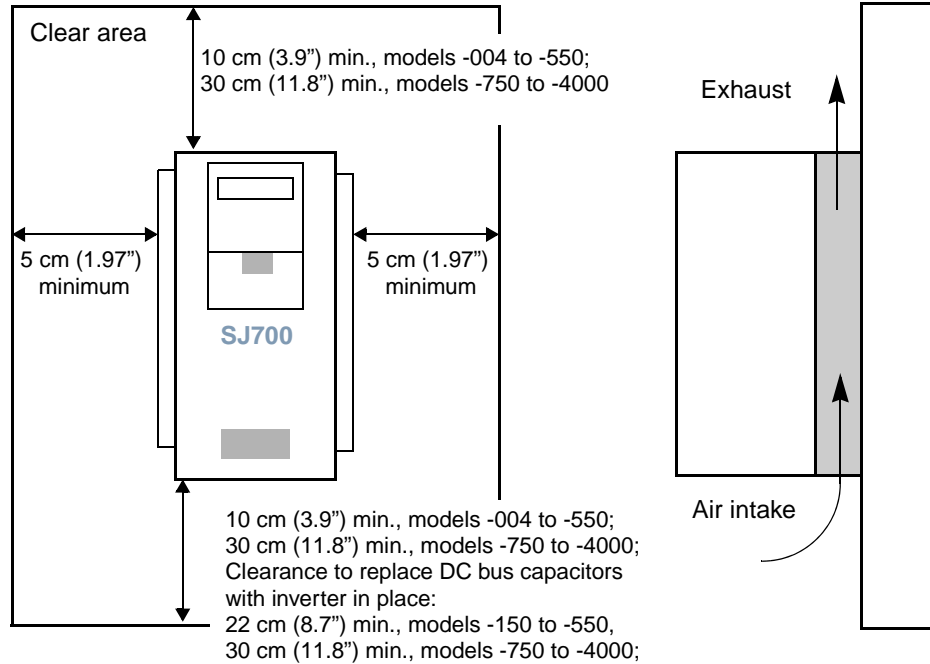

CAUTION: Be sure to maintain the specified clearance area around the inverter and to provide adequate ventilation. Otherwise, the inverter may overheat and cause equipment damage or fire.

4

Keep Debris Out of Inverter Vents

Step 3: Before proceeding to the wiring section, it's a good time to *temporarily* cover the inverter's ventilation openings. Paper and masking tape are all that is needed. This will prevent harmful debris such as wire clippings and metal shavings from entering the inverter during installation.

Please observe this checklist while mounting the inverter:

1. The ambient temperature must be in the range of -10 to 40°C. If the range will be up to 50°C (maximum rating), you will need to refer to derate the output current performance of the inverter.
2. Keep any other heat-producing equipment as far away from the inverter as possible.
3. When installing the inverter in an enclosure, maintain the clearance around the inverter and verify that its ambient temperature is within specification when the enclosure door is closed.
4. Do not open the main front panel door at any time during operation.

Cover the fan outlet vents

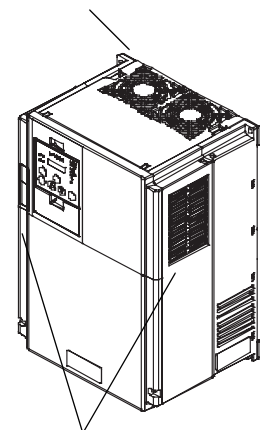

Cover the ventilation slots,
both sides

5

Check Inverter Dimensions

Step 4: Locate the applicable drawing on the following pages for your inverter. Dimensions are given in millimeters (inches) format. Smaller models come equipped with NEMA1 adapter (conduit box) for wire entry for U.S. models (LFU and HFU). The NEMA 1 adapter is optional for larger models as indicated in the drawings.

- Model
- SJ700 -004LFUF2
 - 007LFUF2
 - 007HFUF2/HFEF2
 - 015LFUF2
 - 015HFUF2/HFEF2
 - 022LFUF2
 - 022HFUF2/HFEF2
 - 037LFUF2
 - 040HFUF2/HFEF2

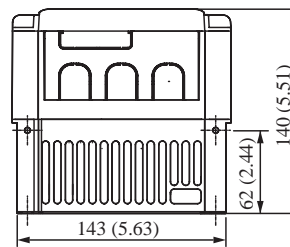
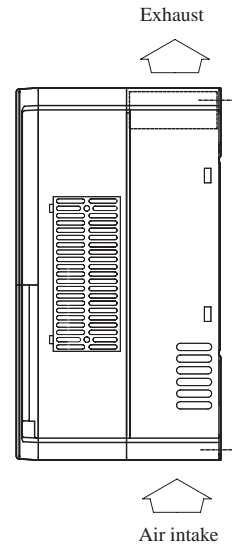
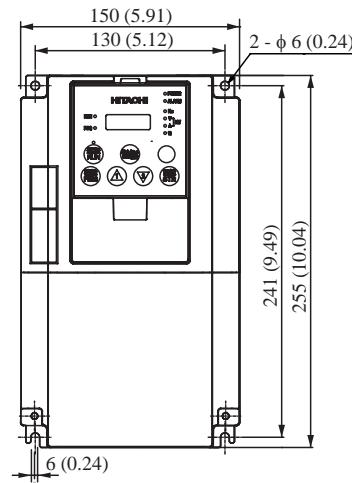

- Model
- SJ700 -055LFUF2
 - 055HFUF2/HFEF2
 - 075LFUF2
 - 075HFUF2/HFEF2
 - 110LFUF2
 - 110HFUF2/HFEF2

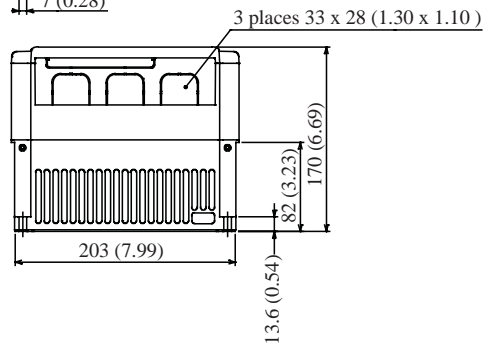
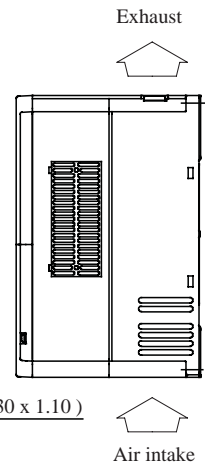
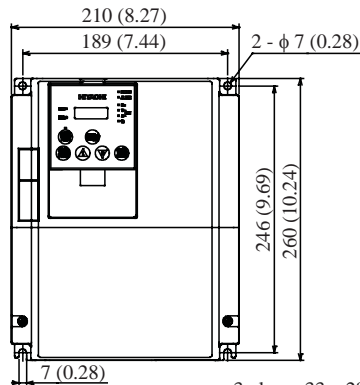

NOTE: Be sure to use lock washers or other means to ensure screws do not loosen due to vibration.

Inverter Mounting and Installation

Dimensional drawings, continued...

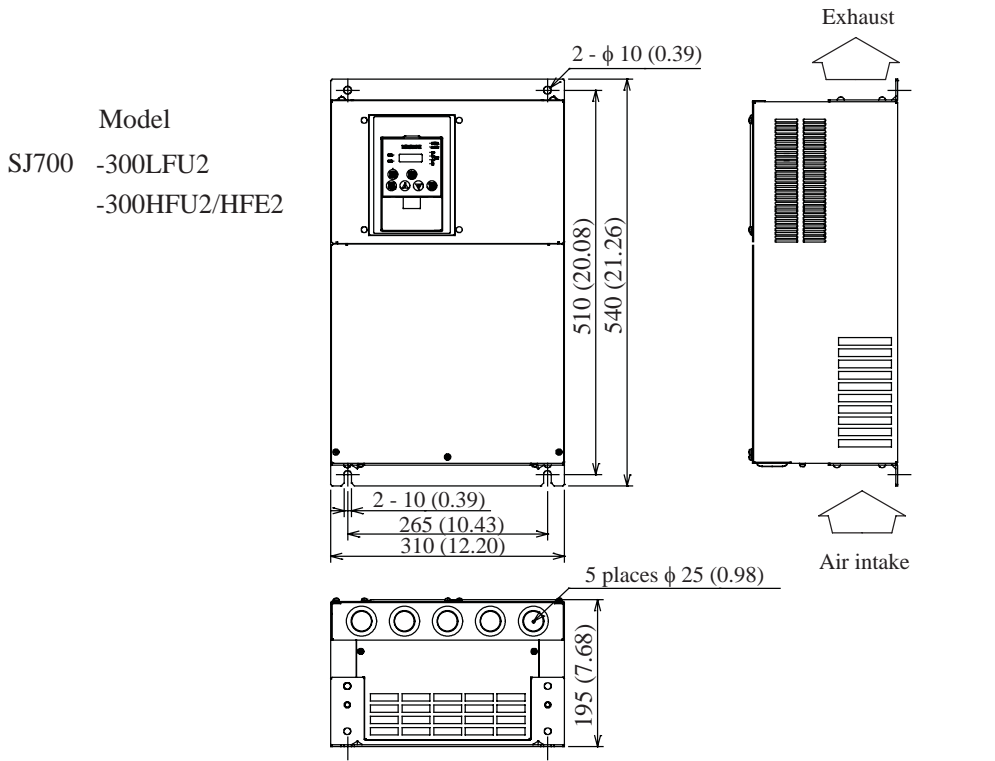
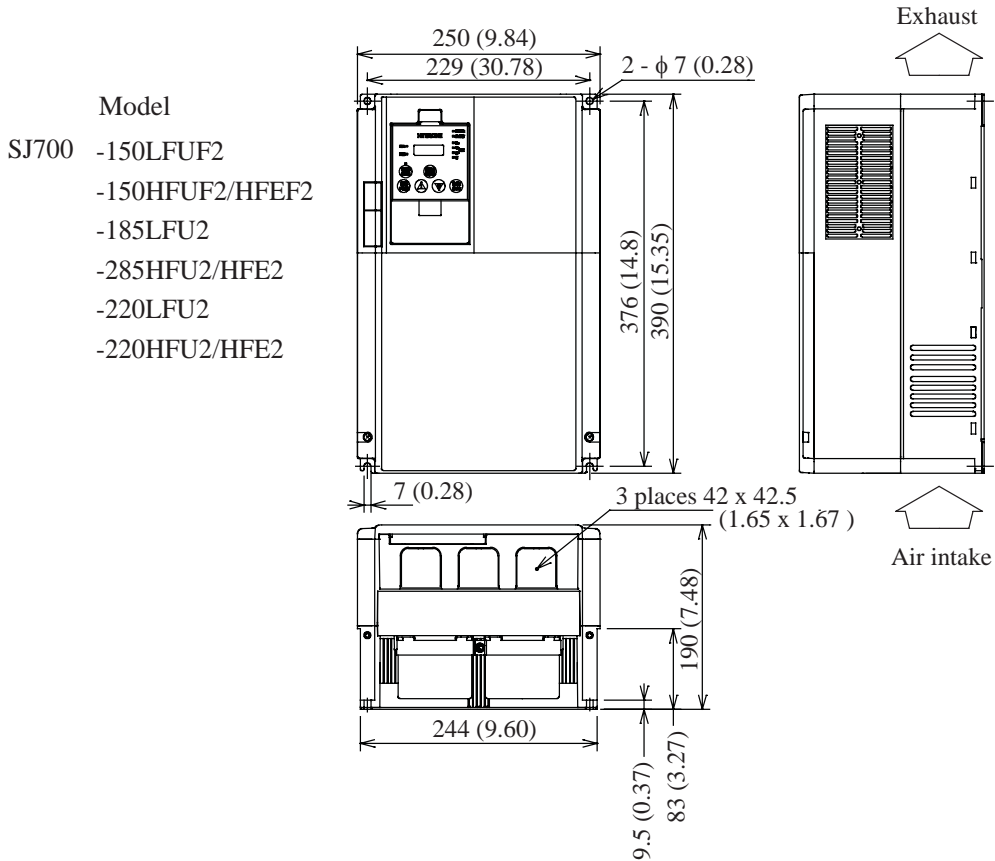

Dimensional drawings, continued...

Model
 SJ700 -370LFU2
 -370HFU2/HFE2
 -450LFU2
 -450HFU2/HFE2
 -550HFU2/HFE2

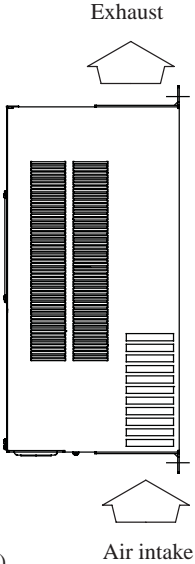
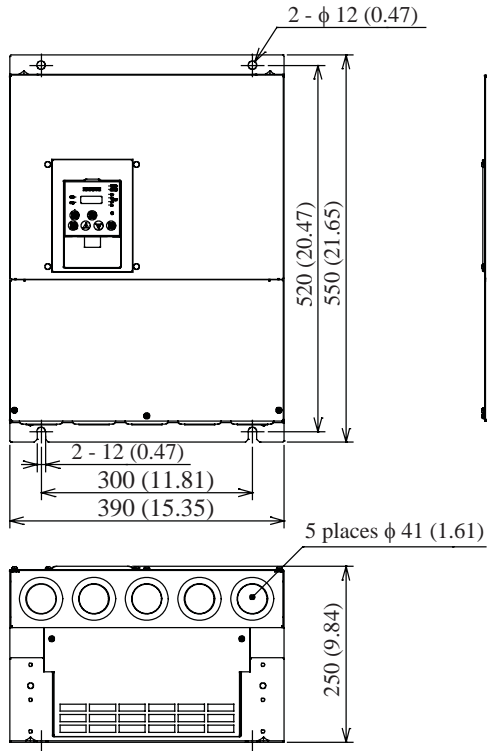

Inverter Mounting and Installation

Model
 SJ700 -550LFU2

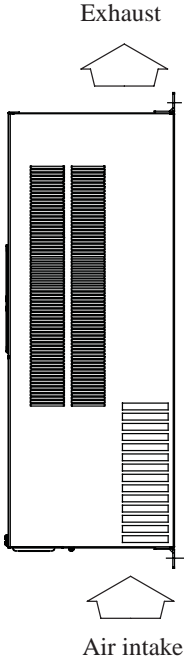
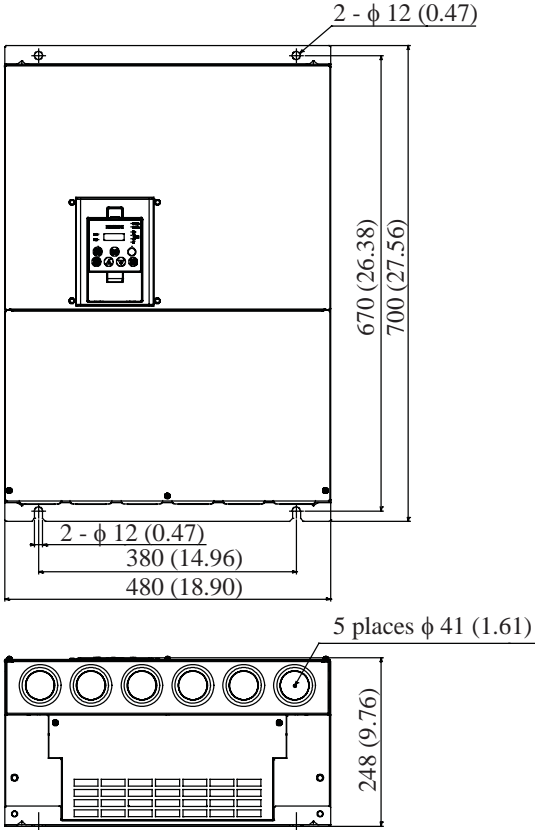

Dimensional drawings, continued...

Model
 SJ700 -750HFU2/HFE2
 -900HFU2/HFE2

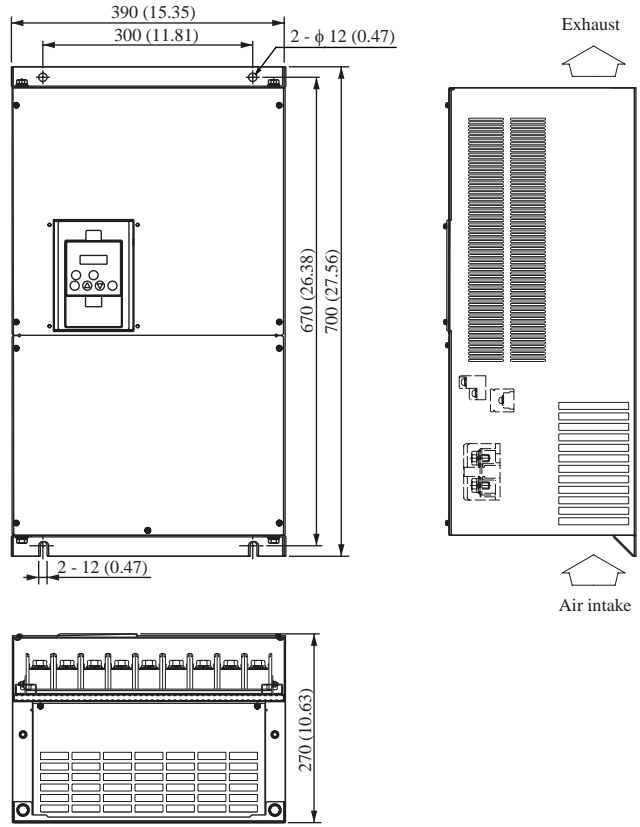

Model
 SJ700 -1100HFU2/HFE2
 -1320HFE2
 -1500HFU2

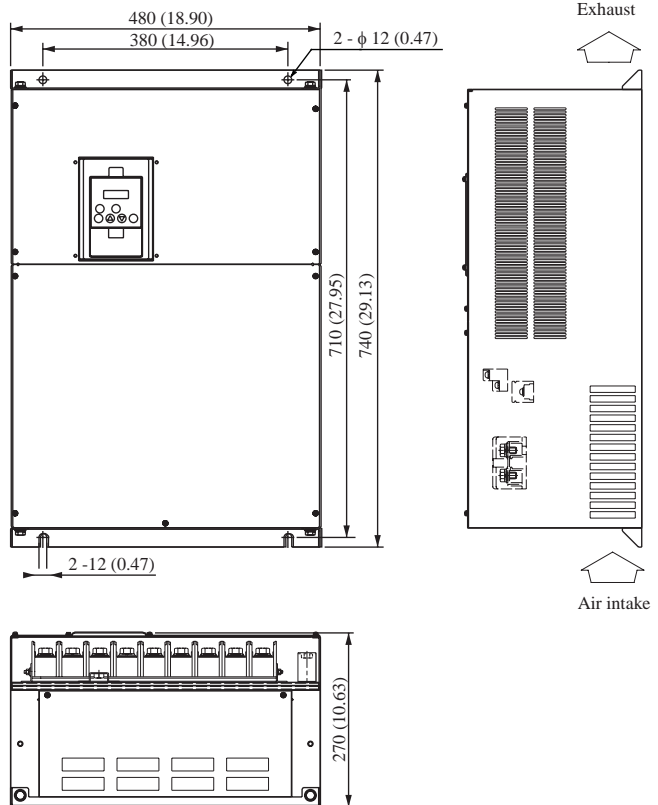

Dimensional drawings, continued...

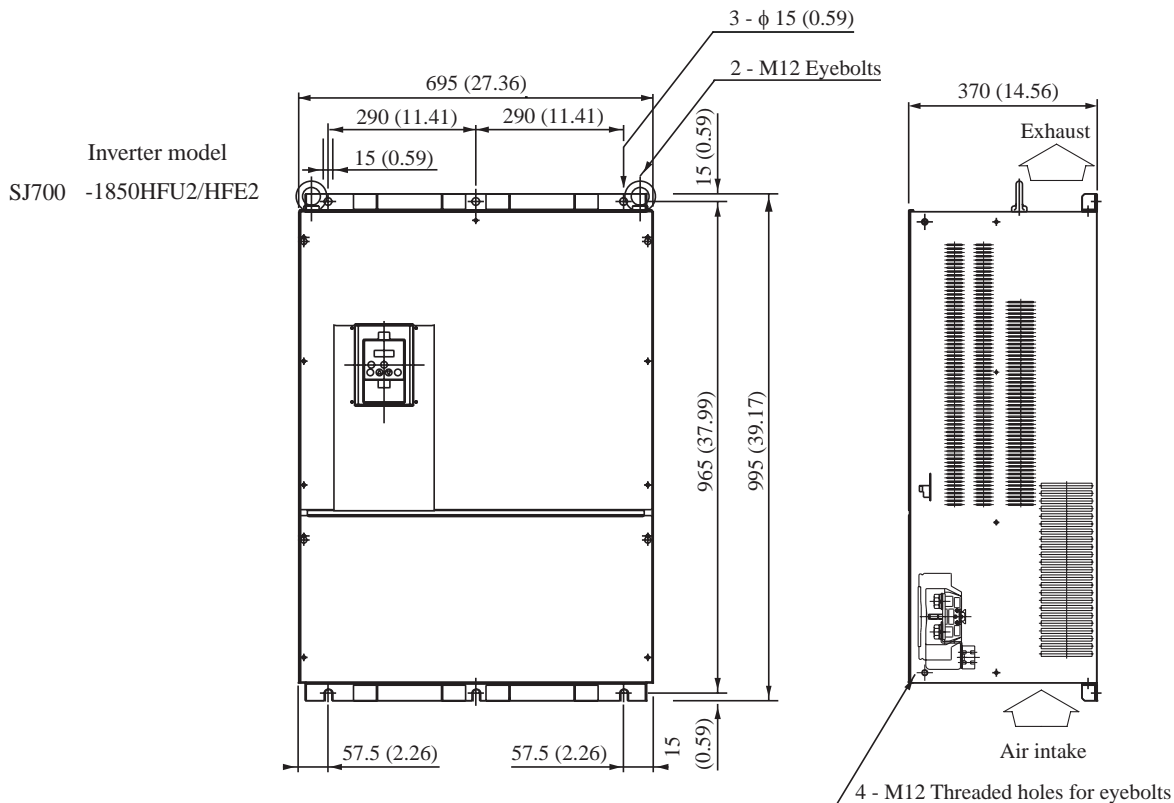

DC reactor model
DCL-H-185

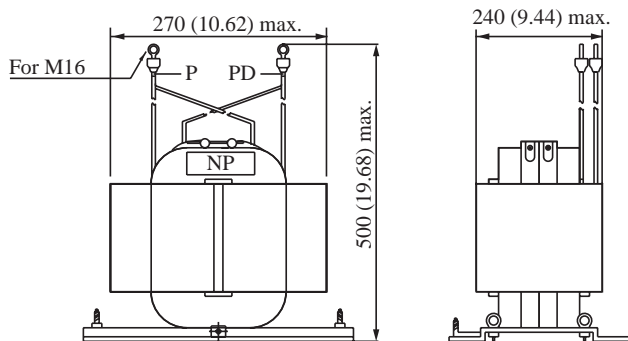
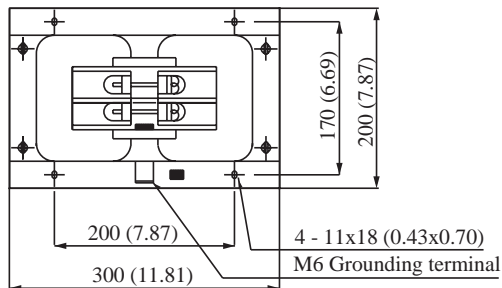

Inverter Mounting
and Installation

Dimensional drawings, continued...



NOTE: The following crimp terminals are included with UL Listed inverter models SJ700-1850HFU2/HFE2.

Terminal Type	Corresponding Stranded Wire Size, (mm ²)	Corresponding Screw Size
R38-8	R26, 66-42, 42	M8
38-16	R26, 66-42, 42	M16
R150-16	117, 2-152, 05	M16

Model
R38 - 8

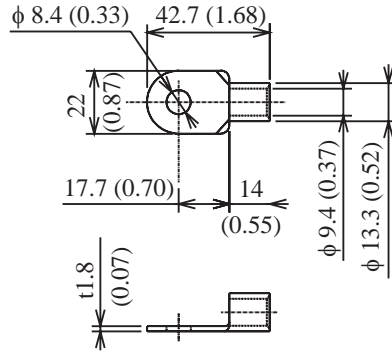

Model
R38 - 16

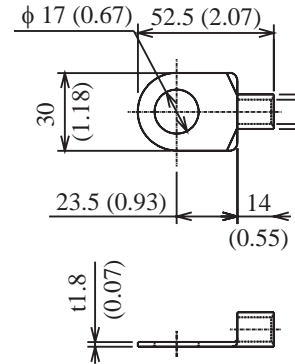

Model
R38 - 8

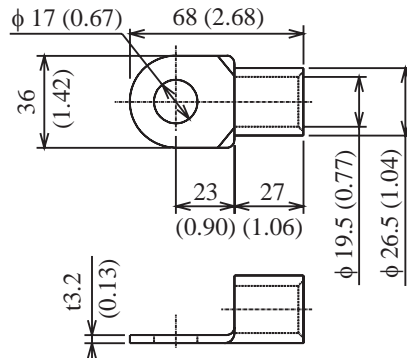

Dimensional drawings, continued...

Inverter model
SJ700 -3150HFU2/HFE2

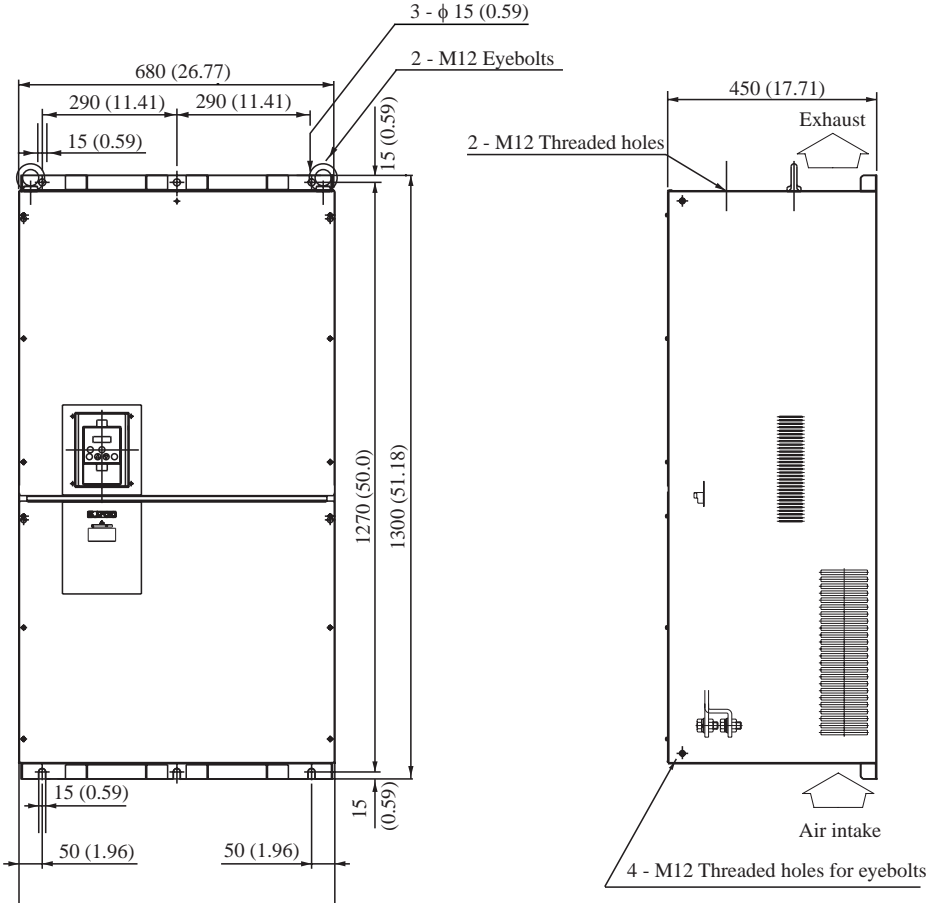

DC reactor model
DCL-H-315

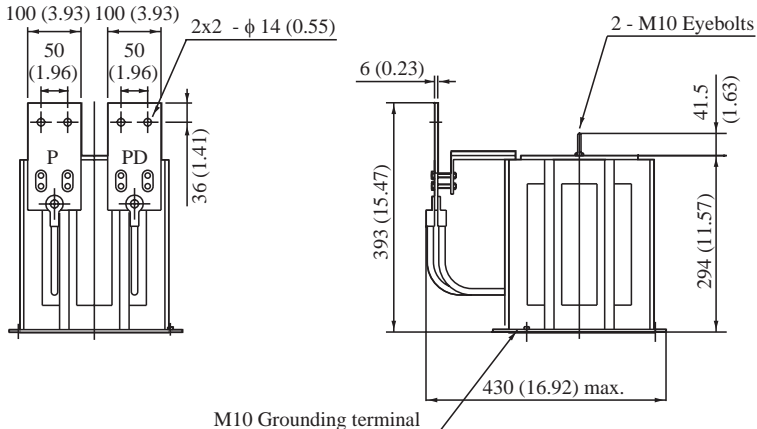
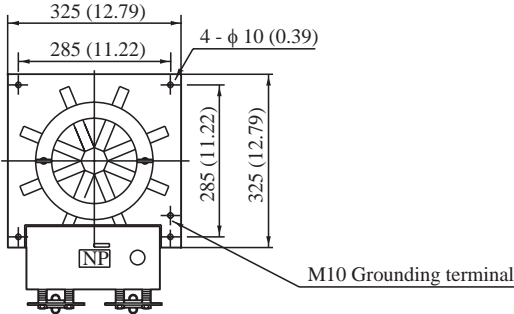

Inverter Mounting
and Installation

Dimensional drawings, continued...

Inverter model
SJ700 -4000HFU2/HFE2

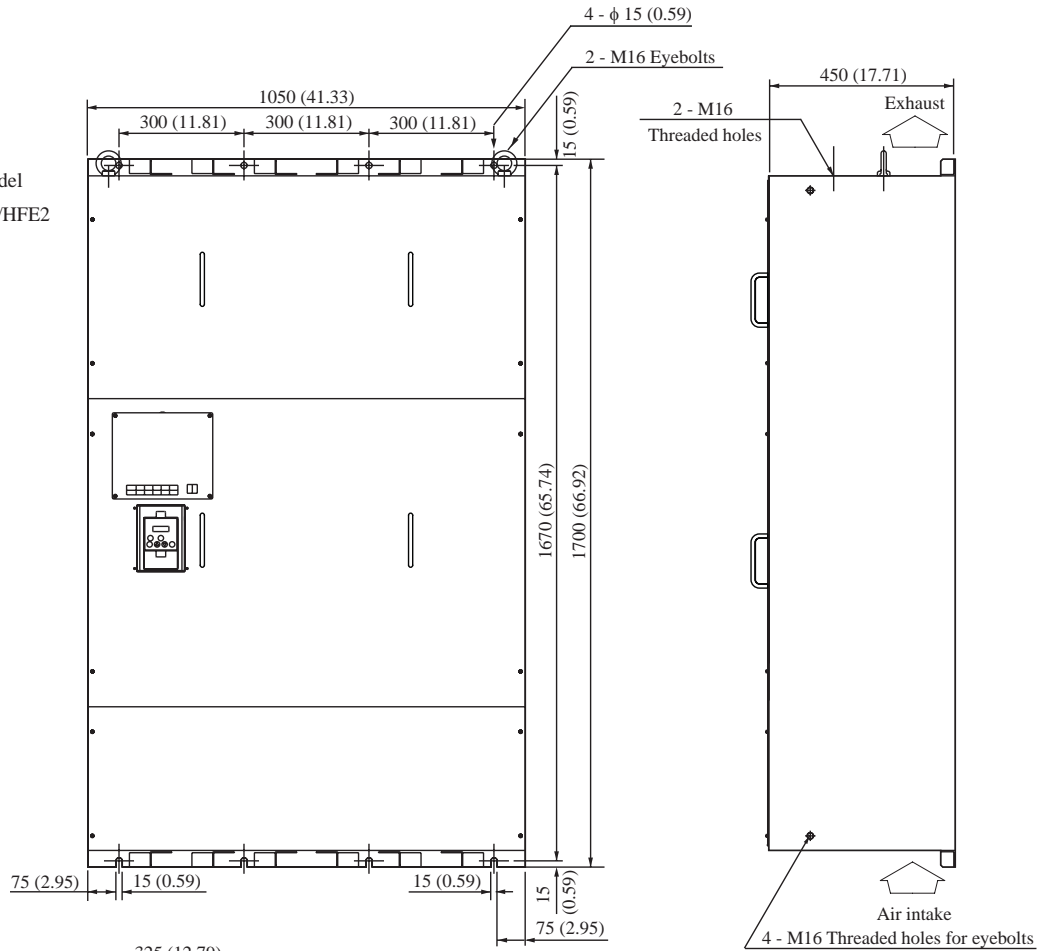

DC reactor model
DCL-H-400

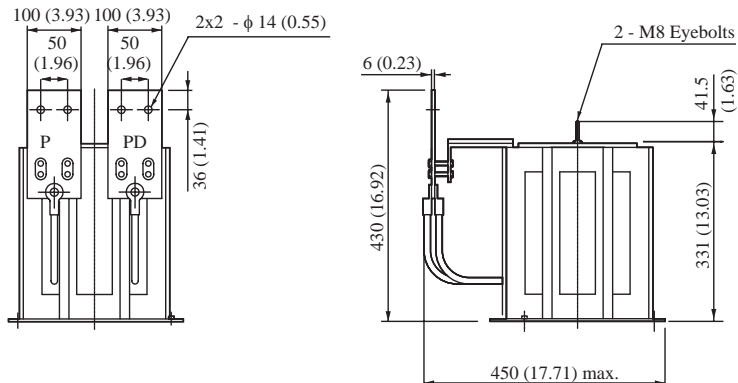
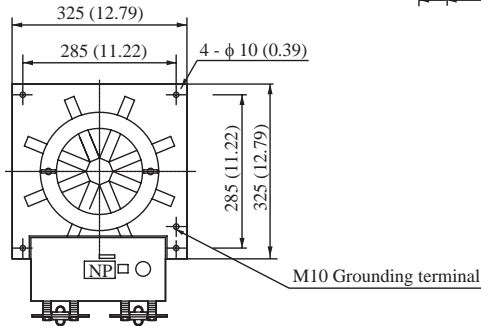

Inverter Mounting and Installation

6

Prepare for Wiring

Step 5: The wiring enters the inverter through an entry/exit plate. For plastic plates, remove the knockout portions of the plate. For metal plates with rubber grommets, cut an "X" in the center of the grommet as shown. Be especially careful to avoid cutting into the thick outer ring, so that the wiring will have a cushion from contacting the metal plate.

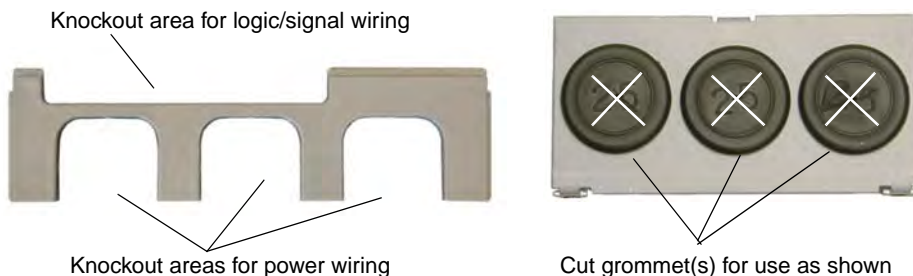

NOTE: Some inverter models will have a wiring box for NEMA rating compliance. Make sure the wire entry to the NEMA box also has protective cushion from chaffing of insulation.

Before proceeding, please study the caution and warning messages below.



WARNING: Use 75°C Cu wire only or equivalent.



WARNING: Open Type Equipment. For models SJ700-750H to SJ700-4000H.



WARNING: A Class 2 circuit wired with Class 1 wire or equivalent.



WARNING: Suitable for use on a circuit capable of delivering not more than 100,000 rms symmetrical amperes, 240 V maximum. For models with suffix L.



WARNING: Suitable for use on a circuit capable of delivering not more than 100,000 rms symmetrical amperes, 480 V maximum. For models with suffix H.



HIGH VOLTAGE: Be sure to ground the unit. Otherwise, there is a danger of electric shock and/or fire.



HIGH VOLTAGE: Wiring work shall be carried out only by qualified personnel. Otherwise, there is a danger of electric shock and/or fire.



HIGH VOLTAGE: Implement wiring after checking that the power supply is OFF. Otherwise, you may incur electric shock and/or fire.



HIGH VOLTAGE: Do not connect wiring to an inverter or operate an inverter that is not mounted according the instructions given in this manual. Otherwise, there is a danger of electric shock and/or injury to personnel.

Inverter Mounting and Installation

Determining Wire and Fuse Sizes

This section includes tables for 200V class and 400V class inverters (on the next page). The following notes will help you read the tables in this section:

- Locate the row corresponding to the motor size and particular inverter in your application. The maximum motor current determines the recommended wire sizes.
- The length column specifies that some inverters can optionally use a smaller wire gauge if the wires are shorter than 10m and the inverter is located in an enclosure.
- Power Lines columns include wires connecting to terminals [R, S, T, U, V, W, P, PD, and N]. Only power input and motor leads will be fused: [R, S, T, U, V, and W]. The breaker ratings (GFI—ground fault interrupter) are slightly higher than fuse ratings to allow for nominal surges without tripping.
- The chassis ground columns list the Hitachi-recommended AWG and the minimal AWG for UL conformity.
- The optional external braking resistor wiring only applies to a few models that have a built-in braking unit. The other models use an optional external braking unit.
- Parallel wires increase effective wire gauge, and are denoted by “||” in the tables.
- Signal Lines, not listed in these tables, connect to the removable logic connector. The recommended wire gauge for all wiring to the logic connector is 28 AWG (0.75 mm²). Be sure to use shielded wire for any analog signals.

Motor Output		200V Inverter Models	Wiring *1								
			Power Lines *3				Chassis Ground			Brake Res.	
HP	kW		AWG	mm ²	Fuse (UL- rated, class J, 600V)	Breaker (GFI type) *2	AWG, rec.	AWG, UL	mm ²	AWG	mm ²
0.5	0.4	SJ700-004LFUF2	20	1.25	10A	10A	20	20	1.25	20	1.25
1	0.75	SJ700-007LFUF2	18	1.25	10A	10A	20	20	1.25	20	1.25
2	1.5	SJ700-015LFUF2	14	2	10A	10A	14	14	2	14	2
3	2.2	SJ700-022LFUF2	14	2	15A	15A	14	14	2	14	2
5	3.7	SJ700-037LFUF2	10	3.5	20A	20A	10	10	3.5	10	3.5
7.5	5.5	SJ700-055LFUF2	8	5.5	30A	30A	8	10	5.5	8	5.5
10	7.5	SJ700-075LFUF2	6	8	40A	40A	8	10	8	6	8
15	11	SJ700-110LFUF2	4	14	60A	60A	4	10	14	10	14
20	15	SJ700-150LFUF2	2	22	80A	80A	3	8	22	8	22
25	18.5	SJ700-185LFU2	1	30	100A	100A	3	8	22	8	30
30	22	SJ700-220LFU2	1	38	125A	125A	2	8	30	6	38
40	30	SJ700-300LFU2	2/0	60 or 22 22	150A	150A	2	6	30	—	—
50	37	SJ700-370LFU2	4/0	100 or 38 38	175A	175A	1/0	6	38	—	—
60	45	SJ700-450LFU2	4/0	100 or 38 38	225A	225A	3/0	6	38	—	—
75	55	SJ700-550LFU2	2/0 2/0	150 or 60 60	250A	250A	3/0	4	60	—	—

* See notes for wiring tables on the following page.

Determining wire and fuse sizes, continued...

Motor Output		400V Inverter Models	Wiring *1								
			Power Lines *3				Chassis Ground			Brake Res.	
HP	kW		AWG/ kcmil	mm ²	Fuse (UL- rated, class J, 600V)	Breaker (GFI type) *2	AWG/ kcmil, rec.	AWG/ kcmil, UL	mm ²	AWG	mm ²
0.5	0.75	SJ700-007HFUF2/E	20	1.25	10A	10A	20	20	1.25	20	1.25
1	1.5	SJ700-015HFUF2/E	18	2	10A	10A	18	18	2	18	2
2	2.2	SJ700-022HFUF2/E	16	2	10A	10A	18	18	2	18	2
3	4.0	SJ700-040HFUF2/E	14	2	15A	15A	18	18	2	18	2
7.5	5.5	SJ700-055HFUF2/E	12	3.5 *5	15A	15A	10	12	3.3 *5	10	3.5 *5
10	7.5	SJ700-075HFUF2/E	10	3.5	20A	20A	10	12	3.5	10	3.5
15	11	SJ700-110HFUF2/E	8	5.5	30A	30A	8	10	5.5	8	5.5
20	15	SJ700-150HFUF2/E	6	8	40A	40A	8	10	8	10	8
25	18.5	SJ700-185HFUF2/E	6	14	50A	50A	4	10	14	10	14
30	22	SJ700-220HFUF2/E	4	14	60A	60A	4	10	14	10	14
40	30	SJ700-300HFUF2/E	3	22	70A	70A	3	10	22	—	—
50	37	SJ700-370HFUF2/E	1	38	90A	90A	3	8	38	—	—
60	45	SJ700-450HFUF2/E	1 1 *6	38	125A	125A	1	8	38	—	—
75	55	SJ700-550HFUF2/E	2/0	60	125A	125A	1	6	60	—	—
100	75	SJ700-750HFUF2/E	1 1 *6	100 or 38 38	175A	175A	3	8	38	—	—
125	90	SJ700-900HFUF2/E	1 1 *6	100 or 38 38	200A	200A	3	8	38	—	—
150	110	SJ700-1100HFUF2/E	1/0 1/0	150 or 60 60	250A	250A	1	6	60	—	—
150	132	SJ700-1320HFE2, SJ700-1500HFUF2	3/0 3/0	80 80	300A	300A	3/0	3/0	80	—	—
250	185	SJ700-1850HFUF2/E	300 300	152 152	400A	400A	250	250	127	—	—
400	315	SJ700-3150HFUF2/E	500 500	253 253	700A	700A	400	400	203	—	—
500	400	SJ700-4000HFUF2/E	800 800	405 405	1000A	1000A	600	600	304	—	—

Note 1: Field wiring must be made by a UL-listed and CSA certified ring lug terminal connector sized for the wire gauge involved. The connector must be fixed by using the crimping tool specified by the connector manufacturer.

Note 2: Be sure to consider the capacity of the circuit breaker to be used.

Note 3: Be sure to use a larger wire gauge if power line length exceeds 66 ft (20m).

Note 4: Prepackaged (included) square washer is to be used when the bare wire is directly connected to terminal without using crimp contact (such as ring lug connector).

Note 5: When replacing J300-055HF or SJ300-055HFF2 inverter with SJ700-055HFF2, you may use power wiring size 2mm².

Note 6: Wire must be rated for operation up to 75°C.

Terminal Dimensions and Torque Specs



The following tables list the screw size of terminal and recommended torque for tightening for each of the SJ7002 inverter models (400V models are on the next page).

CAUTION: Fasten the screws with the specified fastening torque in the table below. Check for any loosening of screws. Otherwise, there is the danger of fire.

200V Class Inverters							
Motor Output		Inverter Model	Screw size of terminal		Ring lug connector *1	Torque	
HP	kW		AWG-bolt	Metric		ft-lbs	N-m
0.5	0.4	SJ700-004LFUF2	20-#10	M4	1.25-4	0.9	1.2
1	0.75	SJ700-007LFUF2	20-#10	M4	1.25-4	0.9	1.2
2	1.5	SJ700-015LFUF2	20-#10	M4	2-4	0.9	1.2
3	2.2	SJ700-022LFUF2	20-#10	M4	2-4	0.9	1.2
5	3.7	SJ700-037LFUF2	20-#10	M4	3.5-4	0.9	1.2
7.5	5.5	SJ700-055LFUF2	8-#12	M5	R5.5-5	1.8	2.4
10	7.5	SJ700-075LFUF2	8-#12	M5	R8-5	1.8	2.4
15	11	SJ700-110LFUF2	4-1/4	M6	R14-6	3.0	4.0
20	15	SJ700-150LFUF2	2-1/4	M6	22-6	3.3	4.5
25	18.5	SJ700-185LFU2	1-1/4	M6	30-S6	3.3	4.5
30	22	SJ700-220LFU2	1/0-5/16	M8	38-8	6.0	8.1
40	30	SJ700-300LFU2	2-5/16	M8	60-8	6.0	8.1
50	37	SJ700-370LFU2	1-5/16	M8 *2	100-8	6.0	8.1
60	45	SJ700-450LFU2	1-5/16	M8 *2	100-8	6.0	8.1
75	55	SJ700-550LFU2	2/0-1/2	M10	150-10	14.5	19.6

Note 1: The recommended ring lug connector listing consists of wire size – screw size format. The wire sizes are in AWG or mm² format. For AWG wire sizes, bolt sizes for the ring lug centers are: #10, #12, 1/4", 5/16", and 1/2". For metric wire sizes, bolt sizes for the ring lug centers are: 6 = 6M, 8 = 8M, 10 = 10M.

Note 2: Prepackaged square washer is to be used when the bare wire is directly connected to terminal without using crimp contact (such as ring lug connector).

Note 3: [N] terminal for braking unit is common to [N] terminal of power lines.



TIP: AWG = American Wire Gauge. Smaller numbers represent increasing wire thickness.
 kcmil = 1,000 circular mils, a measure of wire cross-sectional area
 mm² = square millimeters, a measure of wire cross-sectional area

Terminal dimensions and torque specs, continued...

400V Class Inverters								
Motor Output		Inverter Model	Power connector terminals	Screw size of terminal		Ring lug connector *1	Torque	
HP	kW			(AWG-bolt)	Metric		ft-lbs	N-m
0.5	0.75	SJ700-007HFUF2/E	(All)	20-#10	M4	1.25-4	0.9	1.2
1	1.5	SJ700-015HFUF2/E	(All)	20-#10	M4	1.25-4	0.9	1.2
2	2.2	SJ700-022HFUF2/E	(All)	20-#10	M4	1.25-4	0.9	1.2
3	4.0	SJ700-040HFUF2/E	(All)	20-#10	M4	1.25-4	0.9	1.2
7.5	5.5	SJ700-055HFUF2	(All)	8-#12	M5	5.5-5	1.8	2.4
10	7.5	SJ700-075HFUF2	(All)	8-#12	M5	8-5	1.8	2.4
15	11	SJ700-110HFUF2	(All)	4-1/4	M6	14-6	3.0	4.0
20	15	SJ700-150HFUF2/E	(All)	6-1/4	M6	8-6	3.3	4.5
25	18.5	SJ700-185HFUF2/E	(All)	4-1/4	M6	14-6	3.3	4.5
30	22	SJ700-220HFUF2/E	(All)	4-1/4	M6	14-6	3.3	4.5
40	30	SJ700-300HFUF2/E	(All)	2-1/4	M6	22-6	3.3	4.5
50	37	SJ700-370HFUF2/E	(All)	1/0-5/16	M8 *2	38-8	6.0	8.1
60	45	SJ700-450HFUF2/E	(All)	1/0-5/16	M8 *2	38-8	6.0	8.1
75	55	SJ700-550HFUF2/E	(All)	2-5/16	M8 *2	60-8	6.0	8.1
100	75	SJ700-750HFUF2/E	(All)	1/0-1/2	M10	100-10	14.8	20.0
125	90	SJ700-900HFUF2/E	(All)	1/0-1/2	M10	100-10	14.8	20.0
150	110	SJ700-1100HFUF2/E	(All)	2/0-1/2	M10	150-10	14.8	20.0
150	132	SJ700-1320HFE2, SJ700-1320HFUF2	(All)	2/0-1/2	M10	150-10	14.8	20.0
250	185	SJ700-1850HFUF2/E *3	R, S, T, U, V, W	127 mm ² x 2	M16	R150-16	55.3	75.0
			P, PD, N	152 mm ² x 2	M16	R150-16	55.3	75.0
400	315	SJ700-3150HFUF2/E	R, S, T, U, V, W	203 mm ² x 2	M16	200-16	32.5	44.0
			P, PD, N	253 mm ² x 2	M16	325-16	55.3	75.0
500	400	SJ700-4000HFUF2/E	R, S, T, U, V, W	304 mm ² x 2	M12	325-12	32.5	44.0
			P, PD, N	405 mm ² x 2	M12	*4	38.4	52.0

Note 1: The recommended ring lug connector listing consists of wire size – screw size format. The wire sizes are in AWG or mm² format. For AWG wire sizes, bolt sizes for the ring lug centers are: #10, #12, 1/4", 5/16", and 1/2". For metric wire sizes, bolt sizes for the ring lug centers are: 6 = 6M, 8 = 8M, 10 = 10M.

Note 2: Prepackaged (included) square washer is to be used when the bare wire is directly connected to terminal without using crimp contact (such as ring lug connector).

Note 3: For 1850HF model, use wires with the prepackaged (included) ring lug terminals when connecting the wires to the main circuit terminals.

Note 4: [N] terminal for braking unit is common to [N] terminal of power lines.

7

Wire the Inverter Input to a Supply



Step 6: In this step, you will connect wiring to the input of the inverter. All models have the same power connector terminals [R(L1)], [S(L2)], and [T(L3)] for three-phase input. The three phases may be connected in any order, as they are isolated from chassis ground and do not determine motor direction of rotation. **Please refer to the specifications label (on the front or side of the inverter) for the acceptable input voltage ranges!**

NOTE: The wiring example to the right shows an SJ700-110LFU2 inverter. The terminal locations will vary, depending on the inverter model (see below). Note the use of ring lug connectors for a secure connection.



Use the terminal arrangement below corresponding to your inverter model.



NOTE: Be sure that the power is OFF before changing the jumper settings for [P]/[PD] or for the EMC filter selection.

Inverter models: -004 to -037LFUF2, -007 to -037HFUF2/HFEF2

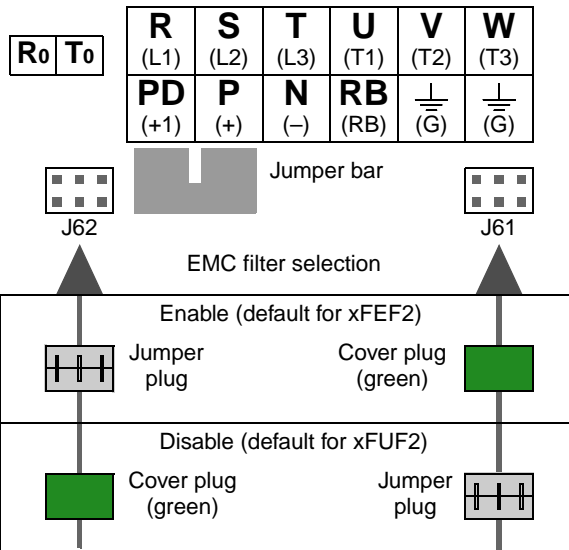

NOTE: For -055xxx and -075xxx (5.5–7.5kW) inverter models: The washer on the main terminal screw (R, S, T, PD, P, N, U, V, W, RB) has two cutouts. To prevent the cable clamping portion of crimp terminal from going under the washer, align the cutouts with the cable as shown below. Otherwise, you run the risk of a loose connection and fire.

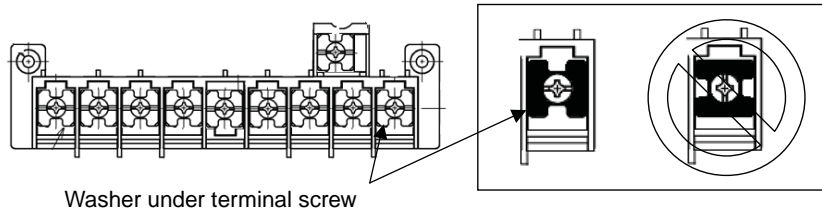

(Terminal diagrams, continued...)

Inverter models: -055 to -110LFUF2, -055 to -110HFUF2/HFEF2

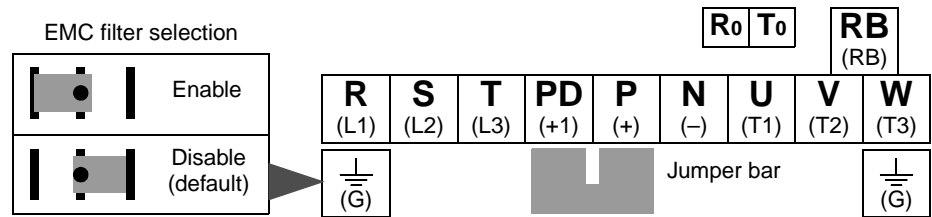

Inverter models: -150LFUF2 to 220LFU2, -150HFUF2 to -220HFU2/HFE2

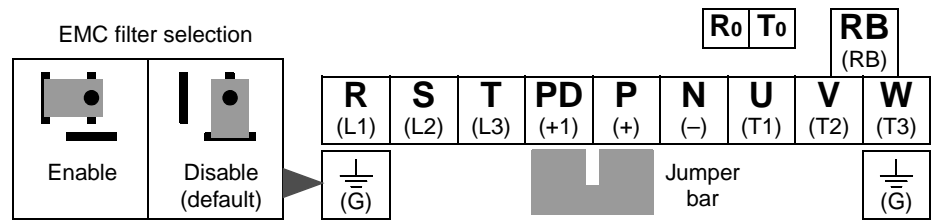

Inverter models: -300 to -370LFU2, -300 to -550HFU2/HFE2

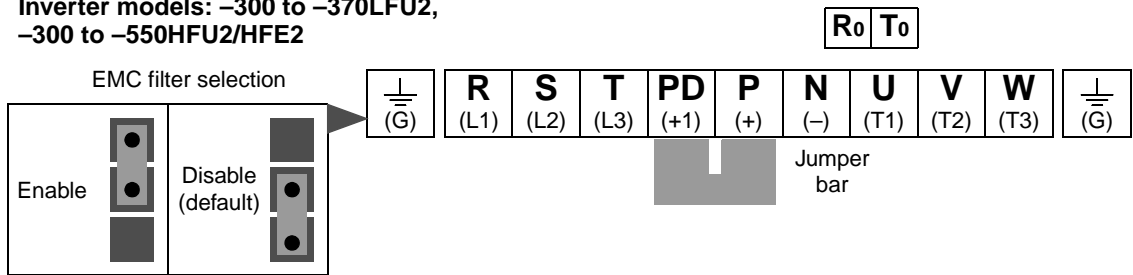

Inverter models: -450LFU2

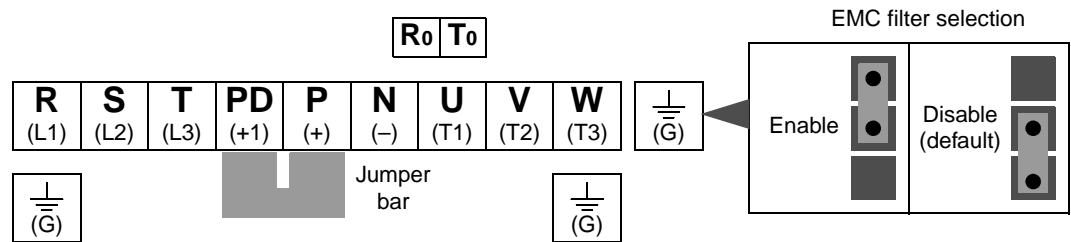

Inverter models: -550LFU2

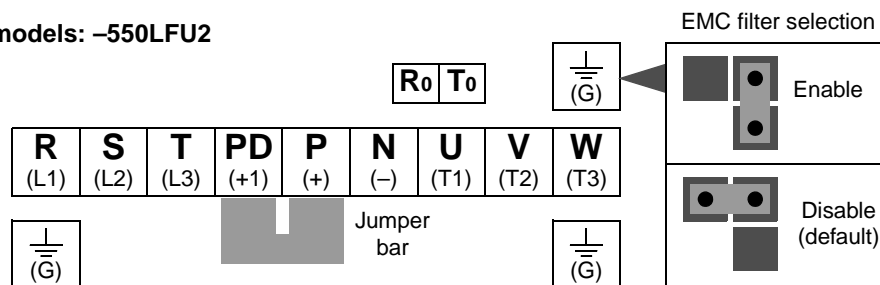

Inverter Mounting and Installation

Inverter model: -750 to 1500HFU2

R₀ T₀

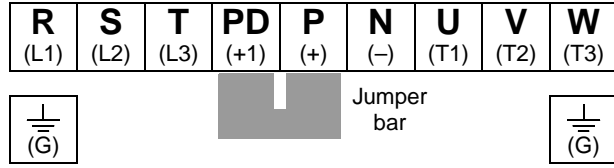

Inverter model: -1850HFU2, HFE2

R₀ T₀

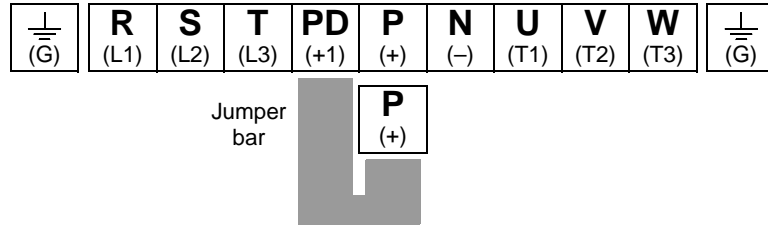

Inverter model: -3150HFU2, HFE2

R₀ T₀

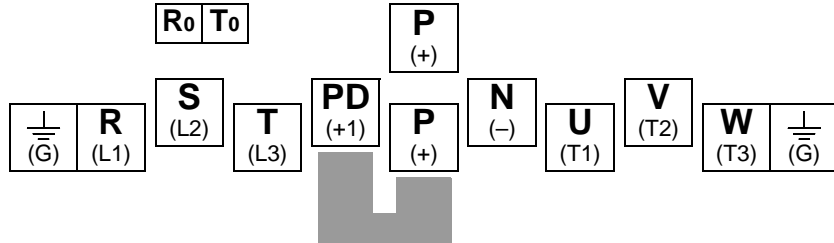

Inverter model: -4000HFU2, HFE2

R₀ T₀

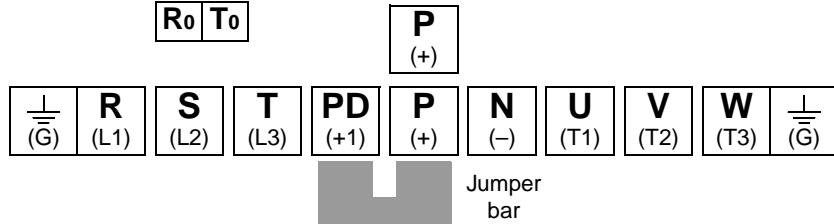

The table below lists the nominal current that may leak from only the inverter when the internal EMC filter is enabled or disabled. Leakage current is in proportion to input power voltage and frequency. The values do not exclude current leakage from external devices and equipment (e.g., power cables). Inverter models from 75 kW to 132 kW does not have a switch to enable/disable the internal EMC filter. This complies EMC directive C3 level in standard condition.

Internal EMC Filter Status	Units	200V Class Inverters (Input voltage = 200VAC, 50 Hz)				400V Class Inverters (Input voltage = 400VAC, 50 Hz)				
		kW	0.4 - 3.7	5.5 - 11	15-37	45-55	.75-3.7	5.5-11	15-37	45-55
Disabled	~mA	0.1	0.1	0.1	0.1	0.2	0.2	0.2	0.2	0.2
Enabled	~mA	2.5	48	23	23	5	95	56	56	—



NOTE: An inverter powered by a portable or emergency diesel power generator may result in a distorted power waveform, overheating the generator. In general, the generator capacity should be at least five times that of the inverter (kVA).



CAUTION: Be sure that the input voltage matches the inverter specifications:

- Three phase 200 to 240V 50/60Hz
- Three phase 380 to 480V 50/60Hz



CAUTION: Be sure not to power a three-phase-only inverter with single phase power. Otherwise, there is the possibility of damage to the inverter and the danger of fire.



CAUTION: Be sure not to connect an AC power supply to the output terminals. Otherwise, there is the possibility of damage to the inverter and the danger of injury and/or fire.

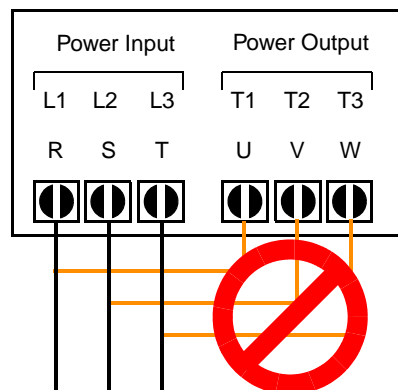

NOTE:

L1, L2, L3:

Three-phase 200 to 240V 50/60 Hz
Three-phase 380 to 480V 50/60 Hz



CAUTION: Remarks for using ground fault interrupter breakers in the main power supply: Adjustable frequency inverters with CE-filters (RFI-filter) and shielded (screened) motor cables have a higher leakage current toward Earth GND. Especially at the moment of switching ON this can cause an inadvertent trip of ground fault interrupter breakers. Because of the rectifier on the input side of the inverter there is the possibility to stall the switch-off function through small amounts of DC current. Please observe the following:

- Use only short time-invariant and pulse current-sensitive ground fault interrupter breakers with higher trigger current.
- Other components should be secured with separate ground fault interrupter breakers.
- Ground fault interrupter breakers in the power input wiring of an inverter are not an absolute protection against electric shock.



CAUTION: Be sure to install a fuse in each phase of the main power supply to the inverter. Otherwise, there is the danger of fire.



CAUTION: For motor leads, ground fault interrupter breakers and electromagnetic contactors, be sure to size these components properly (each must have the capacity for rated current and voltage). Otherwise, there is the danger of fire.

8

Wire the Inverter Output to Motor

Step 7: The process of motor selection is beyond the scope of this manual. However, it must be a three-phase AC induction motor. It should also come with a chassis ground lug. If the motor does not have three power input leads, stop the installation and verify the motor type. Other guidelines for wiring the motor include:

- Use an inverter-grade motor for maximum motor life (1600V insulation).
- For standard motors, use an output filter if the wiring between the inverter and motor exceeds 10 meters in length.

Simply connect the motor to the terminals [U/T1], [V/T2], and [W/T3] indicated on the inverter to the right. This is a good time to connect the chassis ground lug on the drive as well. The motor chassis ground must also connect to the same point. Use a star ground (single-point) arrangement, and never daisy-chain the grounds (point-to-point).

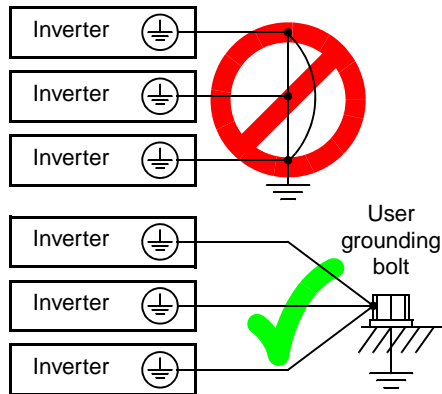

To power source To chassis ground To motor

Use the same wire gauge on the motor and chassis ground wiring as you used on the power input wiring in the previous step. After completing the wiring:

- Check the mechanical integrity of each wire crimp and terminal connection.
- Replace the front panel and secure the retention screw firmly.

Logic Control Wiring

After completing the initial installation and powerup test in this chapter, you may need to wire the logic signal connector for your application. For new inverter users/applications, we highly recommend that you first complete the powerup test in this chapter without adding any logic control wiring. Then you will be ready to set the required parameters for logic control as covered in Chapter 4, Operations and Monitoring.

9

Uncover the Inverter Vents



Step 8: After mounting and wiring the inverter, remove any protective material covering the inverter ventilation openings from Step 3. This includes covers over the side ventilation ports as well as the fan outlet area.

CAUTION: Failure to remove all vent opening covers before electrical operation may result in damage to the inverter.

Uncover the fan outlet vents

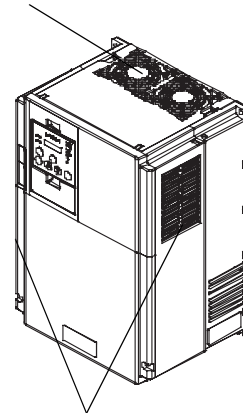

Uncover the ventilation slots, both sides

Powerup Test



Perform the Powerup Test

Step 9: After wiring the inverter and motor, you're ready to do a powerup test. The procedure that follows is designed for the first-time use of the drive. Please verify the following conditions before conducting the powerup test:

- You have followed all the steps in this chapter up to this step.
- The inverter is new, and is securely mounted to a non-flammable vertical surface
- The inverter is connected to a power source and motor.
- No additional wiring of inverter connectors or terminals has been done.
- The power supply is reliable, and the motor is a known working unit, and the motor nameplate ratings match the inverter ratings.
- The motor is securely mounted, and is not connected to any load.

Goals for the Powerup Test

If there are any exceptions to the above conditions at this step, please take a moment to take any measures necessary to reach this basic starting point. The specific goals of this powerup test are:

1. Verify that the wiring to the power supply and motor is correct.
2. Demonstrate that the inverter and motor are generally compatible.
3. Give a brief introduction to the use of the built-in operator keypad.

The powerup test gives you an important starting point to ensure a safe and successful application of the Hitachi inverter. We highly recommend performing this test before proceeding to the other chapters in this manual.

Pre-test and Operational Precautions

The following instructions apply to the powerup test, or to any time the inverter is powered and operating. Please study the following instructions and messages before proceeding with the powerup test.

1. The power supply must have fusing suitable for the load. Check the fuse size chart presented in Step 5, if necessary.
2. Be sure you have access to a disconnect switch for the drive input power if necessary. However, do not turn OFF power to the inverter during its operation unless it is an emergency.
3. Turn the inverter's front panel potentiometer (if it exists) to the *MIN* position (fully counter-clockwise).



CAUTION: The heat sink fins will have a high temperature. Be careful not to touch them. Otherwise, there is the danger of getting burned.



CAUTION: The operation of the inverter can be easily changed from low speed to high speed. Be sure to check the capability and limitations of the motor and machine before operating the inverter. Otherwise, there is the danger of injury.



CAUTION: If you operate a motor at a frequency higher than the inverter standard default setting (50Hz/60Hz), be sure to check the motor and machine specifications with the respective manufacturer. Only operate the motor at elevated frequencies after getting their approval. Otherwise, there is the danger of equipment damage and/or injury to personnel.



CAUTION: Check the following before and during the powerup test. Otherwise, there is the danger of equipment damage.

- Is the shorting bar between the [P] and [PD] terminals installed? DO NOT power or operate the inverter if the jumper is removed.
 - Is the direction of the motor rotation correct?
 - Did the inverter trip during acceleration or deceleration?
 - Were the rpm and frequency meter readings as expected?
 - Were there any abnormal motor vibrations or noise?
-

Powering the Inverter

If you have followed all the steps, cautions and warnings up to this point, you're ready to apply power. After doing so, the following events should occur:

- The *POWER* LED will illuminate.
- The numeric (7-segment) LEDs will display a test pattern, then stop at *0.0*.
- The *Hz* LED will be ON.

If the motor starts running unexpectedly or any other problem occurs, press the *STOP* key. Only if necessary should you remove power to the inverter as a remedy.



NOTE: If the inverter has been previously powered and programmed, the LEDs (other than the *POWER* LED) may illuminate differently than as indicated above. If necessary, you can initialize all parameters to the factory default settings. See [“Restoring Factory Default Settings” on page 6-16](#).

Using the Front Panel Keypad

Front Panel Introduction

Please take a moment to familiarize yourself with the keypad layout shown in the figure below.

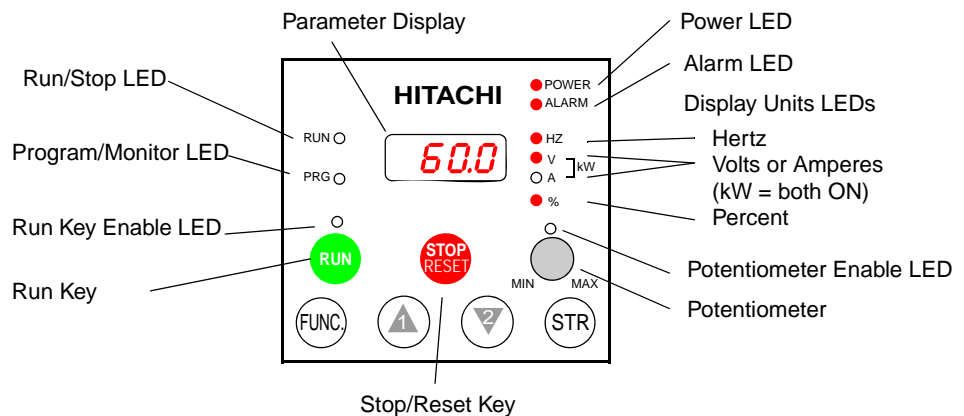

The display is used in programming the inverter's parameters, as well as monitoring specific parameter values during operation. Many functions are applicable only during the initial installation, while others are more useful for maintenance or monitoring.

Parameter Editing and Controls

The front panel controls and indicators are described as follows:

- **Run/Stop LED** – ON when the inverter output is ON and the motor is developing torque, and OFF when the inverter output is OFF (Stop Mode).
- **Program/Monitor LED** – This LED is ON when the inverter is ready for parameter editing (Program Mode). It is normally OFF when the parameter display is monitoring data (Monitor Mode). However, the PRG LED will be ON whenever you are monitoring the value of parameter D001. (When the keypad is enabled as the frequency source via A001=02, you can edit the inverter frequency directly from D001 monitor display by using the Up/Down keys.)
- **Run Key Enable LED** – is ON when the inverter is ready to respond to the Run key, OFF when the Run key is disabled.
- **Run Key** – Press this key to run the motor (the Run Enable LED must be ON first). Parameter F004, Keypad Run Key Routing, determines whether the Run key generates a Run FWD or Run REV command.
- **Stop/Reset Key** – Press this key to stop the motor when it is running (uses the programmed deceleration rate). This key will also reset an alarm that has tripped.
- **Potentiometer** (OPE–SRE only) – allows an operator to directly set the motor speed when the potentiometer is enabled for output frequency control.
- **Potentiometer Enable LED** – ON when the potentiometer is enabled for value entry. (OPE–SRE only).
- **Parameter Display** – a 4-digit, 7-segment display for parameters and function codes.
- **Display Units: Hertz/Volts/Amperes/kW/%** – These LEDs indicate the units associated with the parameter display. When the display is monitoring a parameter, the appropriate LED is ON. In the case of kW units, both Volts and Amperes LEDs will be ON. An easy way to remember this is that $kW = (V \times A)/1000$.
- **Power LED** – This LED is ON when the power input to the inverter is ON.
- **Alarm LED** – This LED is ON when an alarm condition has tripped the inverter. Clearing the alarm will turn this LED OFF again. See Chapter 6 for details on clearing alarms.

- **Function Key** – This key is used to navigate through the lists of parameters and functions for setting and monitoring parameter values.
- **Up/Down (\triangle , ∇) Keys** – Use these keys alternately to move up or down the lists of parameter and functions shown in the display, and increment/decrement values.
- **Store (STR) Key** – When the unit is in Program Mode and the operator has edited a parameter value, press the Store key to write the new value to the EEPROM. This parameter is then displayed at powerup by default. If you want to change the powerup default, navigate to a new parameter value and press the Store key.

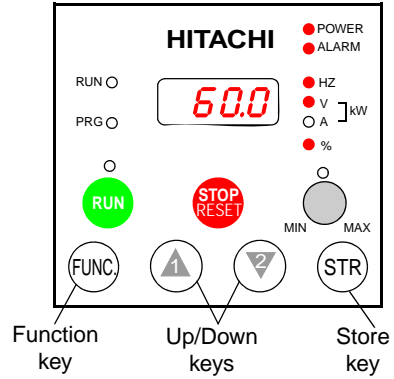

Keys, Modes, and Parameters

Purpose of the keypad is to provide a way to change modes and parameters. The term *function* applies to both monitoring modes and parameters. These are all accessible through *function codes* that are primarily 3 or 4-character codes. The various functions are separated into related groups identifiable by the left-most character, as the table shows.

Function Group	Type (Category) of Function	Mode to Access	PGM LED Indicator
“D”	Monitoring functions	Monitor	\bigcirc or \bullet
“F”	Main profile parameters	Program	\bullet
“A”	Standard functions	Program	\bullet
“B”	Fine tuning functions	Program	\bullet
“C”	Intelligent terminal functions	Program	\bullet
“H”	Motor constant functions	Program	\bullet
“P”	Expansion card functions	Program	\bullet
“U”	User-selectable menu functions	Monitor	\bigcirc
“E”	Error codes	—	—

For example, function “A004” is the *base frequency setting* for the motor, typically 50 Hz or 60 Hz. To edit the parameter, the inverter must be in Program Mode (PGM LED will be ON). You use the front panel keys to first select the function code “A004.” After displaying the value for “A004,” use the Up/Down (\triangle or ∇) keys to edit the value.



NOTE: The inverter 7-segment display shows lower case “b” and “d”, meaning the same as the upper case letters “B” and “D” used in this manual (for uniformity “A to F”).

The inverter automatically switches into Monitor Mode when you access “D” Group functions. It switches into Program Mode when you access any other group, because they all have editable parameters. Error codes use the “E” Group, and appear automatically when a fault event occurs. Refer to [“Monitoring Trip Events, History, & Conditions” on page 6-5](#) for error code details.

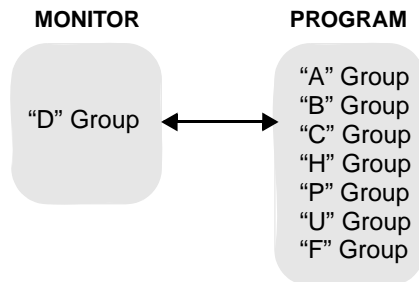

Keypad Navigational Map

The SJ7002 Series inverter drives have many programmable functions and parameters. Chapter 3 will cover these in detail, but you need to access just a few items to perform the powerup test. The menu structure makes use of function codes and parameter codes to allow programming and monitoring with only a 4-digit display and a few keys and LEDs. So, it is important to become familiar with the basic navigational map of parameters and functions in the diagram below. You can later use this map as a reference.

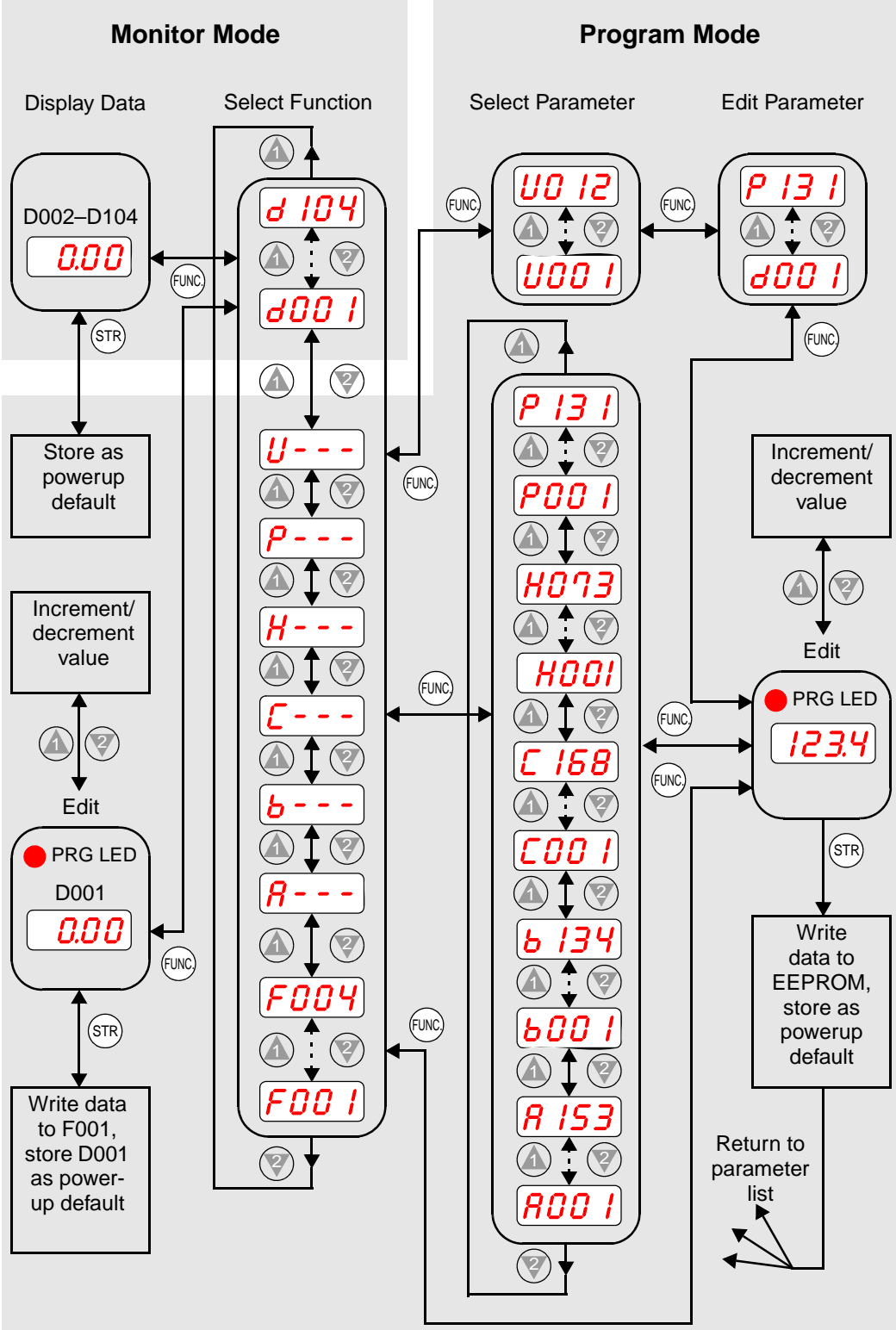

Inverter Mounting and Installation

Selecting Functions and Editing Parameters

In order to run the motor for the powerup test, this section will show how to:

















- select the inverter's maximum output frequency to the motor
- select the keypad potentiometer as the source of motor speed command
- select the keypad as the source of the RUN command
- set the number of poles for the motor
- enable the RUN command

The following series of programming tables are designed for successive use. Each table uses the previous table's final state as the starting point. Therefore, start with the first and continue programming until the last one. If you get lost or concerned that some of the other parameters settings may be incorrect, refer to ["Restoring Factory Default Settings" on page 6-16.](#)





CAUTION: If you operate a motor at a frequency higher than the inverter standard default setting (50Hz/60Hz), be sure to check the motor and machine specifications with the respective manufacturer. Only operate the motor at elevated frequencies after getting their approval. Otherwise, there is the danger of equipment damage.

Setting the Motor Base Frequency -The motor is designed to operate at a specific AC frequency. Most commercial motors are designed for 50/60 Hz operation. First, check the motor specifications. Then follow the steps in the table below to verify the setting or correct for your motor. DO NOT set it for greater than 50/60 Hz unless the motor manufacturer specifically approves operation at the higher frequency.

Action	Display	Func./Parameter
Press the  key.		Monitor functions
Press the  or  keys until ->		"A" Group selected
Press the  key.		First "A" parameter
Press the  key twice.		Base frequency setting
Press the  key.	 or 	Default value for base frequency US = 60 Hz, Europe = 50 Hz
Press the  or  key as needed.		Set to your motor specs (your display may be different)
Press the  key.		Stores parameter, returns to "A" Group list











TIP: If you need to scroll through a function or parameter list, press and hold the  or  key to auto-increment through the list.









Select the Potentiometer for Speed Command - The motor speed may be controlled from the following sources:

- Potentiometer on front panel keypad (if present)
- Control terminals
- Remote panel

Then follow the steps in the table below to select the potentiometer for the speed command (the table resumes action from the end of the previous table).

Action	Display	Func./Parameter
Press the  key twice.		Speed command source setting
Press the  key.		0 = potentiometer 1 = control terminals (default) 2 = keypad
Press the  key.		0 = potentiometer (selected)
Press the  key.		Stores parameter, returns to “A” Group list

Select the Keypad for the RUN Command - The RUN command causes the inverter to accelerate the motor to the selected speed. You can program the inverter to respond to either the control terminal signal or the keypad RUN key. Follow the steps in the table below to select the front panel RUN key as the source for the RUN Command (the table resumes action from the end of the previous table).















Action	Display	Func./Parameter
Press the  key.		Run command source
Press the  key.		1 = control terminals (default) 2 = keypad
Press the  key.		2 = keypad (selected)
Press the  key.		Stores parameter, returns to “A” Group list



NOTE: When you press the STR key in the last step above (and the display = 02), the Run Enable LED above the RUN switch on the keypad will turn ON. This is normal, and does not mean the motor is trying to run. It means that the RUN key is now enabled. DO NOT press the RUN key at this time—finish out the programming exercise first.

Configure the Inverter for the Number of Motor Poles- The number of magnetic poles of a motor is determined by the motor's internal winding arrangement. The specifications label on the motor usually indicates its number of poles. For proper operation, verify the parameter setting matches the motor poles. Many industrial motors have four poles, corresponding to the default setting in the inverter.

Follow the steps in the table below to verify the motor poles setting and change it if necessary (the table resumes action from the end of the previous table.)

Action	Display	Func./Parameter
Press the  key.		"A" Group selected
Press the  key three times.		"H" Group selected
Press the  key.		First "H" parameter
Press the  key five times.		Motor poles parameter
Press the  key.		2 = 2 poles 4 = 4 poles (default) 6 = 6 poles 8 = 8 poles
Press the  or  key as needed.		Set to match your motor (your display may be different)
Press the  key.		Stores parameter, returns to "H" Group list

This step concludes the parameter setups for the inverter. You are almost ready to run the motor for the first time!



TIP: If you became lost during any of these steps, first observe the state of the PRG LED. Then study the ["Keypad Navigational Map" on page 2-31](#) to determine the current state of the keypad controls and display. As long as you do not press the STR key, no parameters will be changed by keypad entry errors. Note that power cycling the inverter will not cause it to reset to a particular programming state.

The next section will show you how to monitor a particular parameter from the display. Then you will be ready to run the motor.

Monitoring Parameters with the Display

After using the keypad for parameter editing, it's a good idea to switch the inverter from Program Mode to Monitor Mode. This will turn out the PRG LED, and the Hertz, Volt, Ampere, or % LED indicates the display units.

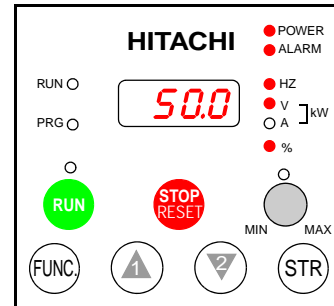

For the powerup test, monitor the motor speed indirectly by viewing the inverter's output frequency. The *output frequency* must not be confused with *base frequency* (50/60 Hz) of the motor, or the *carrier frequency* (switching frequency of the inverter, in the kHz range). The monitoring functions are in the "D" list, located near the top left of the diagram in the ["Keypad Navigational Map" on page 2-31](#).

Output frequency (speed) monitor - Resuming the keypad programming from the previous table, follow the steps in the table below.

Action	Display	Func./Parameter
Press the key.		"H" Group selected
Press the key.		Output frequency selected
Press the key.		Output frequency displayed

When the *d001* function code appeared, the PRG LED went OFF. This confirms the inverter is no longer in programming mode, even while you are selecting the particular monitoring parameter. After pressing the FUNC. key, the display shows the current speed (is zero at this point).

Running the Motor

If you have programmed all the parameters up to this point, you're ready to run the motor! First, review this checklist:

1. Verify the Power LED is ON. If not, check the power connections.
2. Verify the Run Key Enable LED is ON. If not, review the programming steps to find the problem.
3. Verify the PRG LED is OFF. If it is ON, review the instructions above.
4. Make sure the motor is disconnected from any mechanical load.
5. Turn the potentiometer to the MIN position (completely counterclockwise).
6. Now, press the RUN key on the keypad. The RUN LED will turn ON.
7. Slowly increase the potentiometer setting in clockwise fashion. The motor should start turning when the indicator is in the 9:00 position and beyond.
8. Press the STOP key to stop the motor rotation.

Inverter Mounting and Installation

11

Powerup Test Observations and Summary

Step 10: Reading this section will help you make some useful observations when first running the motor.

Error Codes - If the inverter displays an error code (LED format is “E--”), see [“Monitoring Trip Events, History, & Conditions”](#) on page 6-5 to interpret and clear the error.

Acceleration and Deceleration - The SJ7002 inverter has programmable acceleration and deceleration values. The test procedure left these at the default value, 10 seconds. You can observe this by setting the potentiometer at about half speed before running the motor. Then press RUN, and the motor will take 5 seconds to reach a steady speed. Press the STOP key to see a 5 second deceleration to a stop.

State of Inverter at Stop - If you adjust the motor’s speed to zero, the motor will slow to a near stop, and the inverter turns the outputs OFF. The high-performance SJ7002 can rotate at a very slow speed with high torque output, but not zero (must use servo systems with position feedback for that feature). This characteristic means you must use a mechanical brake for some applications.

Interpreting the Display - First, refer to the output frequency display readout. The maximum frequency setting (parameter A004) defaults to 50 Hz or 60 Hz (Europe and United States, respectively) for your application.

Example: Suppose a 4-pole motor is rated for 60 Hz operation, so the inverter is configured to output 60 Hz at full scale. Use the following formula to calculate the RPM.

$$\text{RPM} = \frac{\text{Frequency} \times 60}{\text{Pairs of poles}} = \frac{\text{Frequency} \times 120}{\# \text{ of poles}} = \frac{60 \times 120}{4} = 1800\text{RPM}$$

The theoretical speed for the motor is 1800 RPM (synchronous speed). However, an induction motor cannot generate torque unless its shaft turns at a slightly different speed. This difference is called *slip*. So it’s common to see a rated speed of approximately 1750 RPM on a 60 Hz, 4-pole motor. Using a tachometer to measure shaft speed, you can see the difference between the inverter output frequency and the actual motor speed. The slip increases slightly as the motor’s load increases. This is why the inverter output value is called “frequency,” since it is not exactly equal to motor speed. You can program the inverter to display output frequency in units more directly related to the load speed by entering a constant (discussed more in depth on page 3-45).

Run/Stop Versus Monitor/Program Modes –

The Run LED on the inverter is ON in Run Mode, and OFF in Stop Mode. The Program LED is ON when the inverter is in Program Mode, and OFF for Monitor Mode. All four mode combinations are possible. The diagram to the right depicts the modes and the mode transitions via keypad.

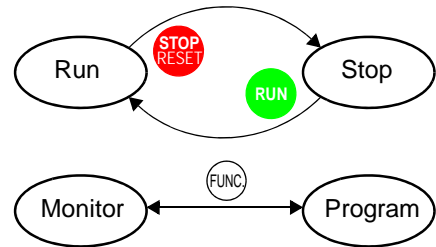

NOTE: Some factory automation devices such as PLCs have alternate Run/Program modes; the device is in either one mode or the other. In the Hitachi inverter, however, Run Mode alternates with Stop Mode, and Program Mode alternates with Monitor Mode. This arrangement lets you program some values while the inverter is operating—providing flexibility for maintenance personnel.



Emergency Stop Function

Introduction

The SJ700 series inverter has the function of “uncontrolled stopping by removal of motor power” in accordance with Stop Category 0 defined by EN60204-1. The inverter is also designed to comply with Safety Category 3 of EN954-1. This function is generally called Safe Stop function. The emergency stop function shuts off the inverter output (i.e. stops the switching operation of the main circuit elements) in response to a command from a hardware circuit via an intelligent input terminal without the operation by internal CPU software.

Carefully note the following points when installing or using the Emergency Stop Function:

- The emergency stop function does not electrically shut off the inverter but merely stops the switching operation of the main circuit elements. Therefore, do not touch any terminals of the inverter or any power lines, e.g., motor cables. Otherwise, electric shock, injury, or ground fault may result.
- All systems that include an inverter must comply with the requirements of EN60204-1 (safety of machinery) and other applicable standards. You must confirm the contents of standards applicable to your system.
- Before installing a system using Safe Stop function, you must fully examine whether Safe Stop function and the safety category to be applied are adequate for your system. For details, refer to the standards required for your system.
- Every system must be configured with an inverter, a motor, and an external shutoff device. The external shutoff device must at least comply with Safety Category 3 of EN954-1.
- Safe Stop function is not intended for electrical insulation between the inverter and motor. If necessary, connect a shut off device (e.g., contactor) to the motor connection cable.
- Safe Stop function is not designed to prevent malfunctions in drive process control and application functions.
- Carefully note that digital outputs (i.e., relay and open collector outputs) are not regarded as the safety-related signals described here. The signals output from externally installed safety relays must be used for the safety-related control circuits installed for your system.

Inverter Configuration



To enable the emergency stop function, set the slide lever of slide switch SW1 to ON. The factory default SW1 setting is OFF (Emergency Stop disabled).

NOTE: Before operating slide switch SW1, make sure that the input power supply is off.

NOTE: Carefully note that improperly turning slide switch SW1 ON or OFF will automatically change function assignments to the control terminals of the inverter.

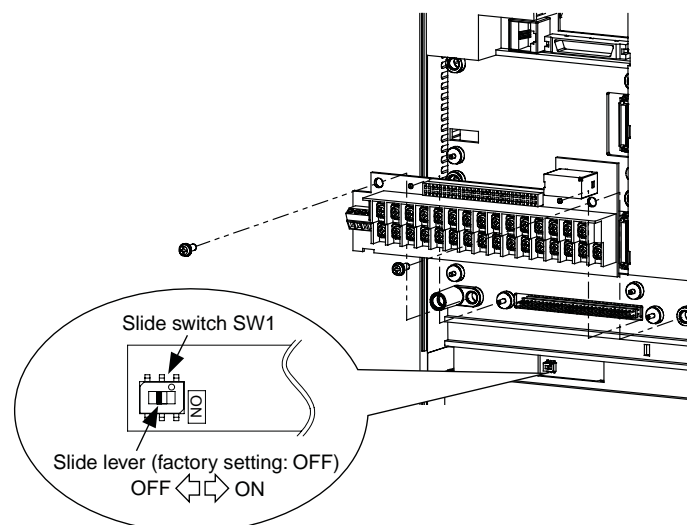

When the emergency stop function is enabled, intelligent input terminals [1] and [3] are used exclusively for this function, and no other functions can be assigned to these terminals. Even if other functions have been assigned to these terminals, these are automatically disabled and these terminals are used exclusively for the emergency stop function.

Terminal [1] function – This terminal always serves as the “a” (N.O.) contact for the reset [RS] signal. This signal resets the inverter and releases the inverter from the trip due to emergency stop (error code E37).

Terminal [3] function – This terminal always serves as the “b” (N.C.) contact for the emergency stop [EMR] signal. This signal shuts off the inverter output without the operation by internal CPU software. This signal makes the inverter trip due to emergency stop (error code E37).



NOTE: If intelligent input terminal [3] is left unconnected, the cable connected to the terminal is disconnected, or the signal logic is improper, the inverter trips due to emergency stop (E37). If this occurs, check and correct the wiring and signal logic, and then input the reset [RS] signal. Only the reset [RS] signal input from intelligent input terminal [1] can release the inverter from tripping due to emergency stop (E37). The inverter cannot be released from the E37 trip status by any operation from the digital operator.

SW1 Switch Setting	Intelligent input terminal [1]				Intelligent input terminal [3]			
	Function selection (normally C001)		a/b (N.O./N.C.) selection (use C011) *1		Function selection (normally C003)		a/b (N.O./N.C.) selection (use C013) *1, *2	
OFF – Emergency Stop disabled (factory setting)	User selectable *4		User selectable *4		User selectable *4		User selectable *4	
	Factory setting	[RS], code 18	Factory setting	N.O., code 00	Factory setting	[JG], code 06	Factory setting	N.O., code 00
ON – Emergency Stop enabled	Automatic assignment of functions to intelligent input terminals [1] and [3] and the terminal assigned [RS] (code 18) *3							
	Fixed (cannot be changed)	[RS], code 18	Fixed (cannot be changed)	N.O., code 00	Fixed (cannot be changed)	[EMR], code 64	Fixed (cannot be changed)	N.C., code 01
ON (after set to OFF once) – Emergency Stop disabled *3, *5	User selectable *4		User selectable *4		User selectable *4		User selectable *4	
	Setting retained when SW1 is set ON	[RS], code 18	Setting retained when SW1 is set ON	N.O., code 00	Released from emergency stop function	(No function assigned)	Setting retained when SW1 is set ON	N.C., code 01

Note 1: When function [RS] (code 18) is assigned to the input terminal, “a/b (N.O./N.C.)” selection is always 00 (N.O.).

Note 2: When terminal setting C003 is [EMR] (code 64), terminal setting C013 is always 01 (N.C.).

Note 3: If function [RS] (code 18) has been assigned to an intelligent input terminal other than intelligent input terminals [1] and [3] before slide switch SW1 is set to ON, the input terminal setting for that terminal is automatically changed to NO (no function assigned) when slide switch SW1 is set to ON. This prevents any duplication of terminal functions. Even if slide switch SW1 is subsequently turned OFF, the original function setting for the terminal will not be restored. If necessary, the original function will have to be reassigned to the terminal.

Example – If slide switch SW1 is set to ON when function [RS] (code 18) has been assigned to input terminal 2 (by terminal setting C002), terminal setting C002 is changed to NO (no function assigned), and function [RS] (code 18) is assigned to input terminal 1 (by terminal setting C001). Even if slide switch SW1 is subsequently

turned OFF, terminal [2] function C002 and terminal [1] function C001 will remain as NO (no function assigned) and [RS] (code 18), respectively.

Note 4: Function [EMR] (code 64) cannot be assigned to input terminal 3 by an operation from the digital operator. The function is automatically assigned to the terminal when slide switch SW1 is set to ON.

Note 5: After slide switch SW1 has been set to ON once, function assignments to intelligent input terminals [1] and [3] are *not* returned to their original assignments. If necessary, reassign original functions to the intelligent input terminals.

Copying Inverter Data

Note that data from an inverter configured for the emergency stop function can affect copy operations when using an optional operator (SRW or SRW-EX).

If operator data is copied to a SJ700 series inverter that has slide switch SW1 in the ON position from another SJ700 series inverter whose slide switch SW1 is OFF or an SJ300 series inverter, the digital operator on your SJ700 series inverter may display [R-ERROR COPY ROM] for a moment. This event may occur because the data on intelligent input terminals [1] and [3] cannot be copied since, on your inverter, exclusive functions have already been assigned to intelligent input terminals [1] and [3] due to the slide switch SW1 setting to ON. Note that other data is copied. If this event occurs, check the settings on both copy-source and copy-destination inverters.



NOTE: To use the copied data in inverter operation, power OFF and ON again after the copy operation is complete.

Safety Categories The following Safety Categories are defined by EN954-1 (JIS B 9705).

Category	Safety requirement	System behavior	Principle for achieving safety
B	Components, safety-related parts of control system, and protective equipment must be designed, manufactured, selected, assembled, and combined in accordance with related standards to ensure resistance to the anticipated adverse effects of faults.	A defect (fault) may cause a loss of the safety function.	Characterized mainly by the selection of components
1	The requirements of Category B must be applied. Proven components and safety principles must be applied.	A defect (fault) may cause a loss of the safety function. However, the probability of loss is less than that specified for Category B.	
2	The requirements of Category B and proven safety principle specifications must be applied. The safety function must be checked by the machine control system at appropriate intervals. The requirements of category B and proven safety principle specifications must be applied. Safety-related parts must be designed to meet the following requirements: <ul style="list-style-type: none"> Any single defect (fault) in a part must not cause any loss of the safety functions. If a single defect (fault) occurs, it must always be detected when the safety function can be reasonably implemented. 	<ul style="list-style-type: none"> A defect (fault) occurring during checking may cause a loss of the safety function. A loss of the safety function is detected by checking. 	Characterized mainly by the structure

Category	Safety requirement	System behavior	Principle for achieving safety
3	<p>The requirements of category B and proven safety principle specifications must be applied. Safety-related parts must be designed to meet the following requirements:</p> <ul style="list-style-type: none"> • The safety function always operates when a single defect (fault) occurs. • Each single defect (fault) is eventually detected to prevent the loss of the safety function. 	<ul style="list-style-type: none"> • The safety function always operates when a single defect (fault) occurs. • Almost all defects (faults) are detected. • Accumulation of undetected defects (faults) may cause a loss of the safety function. 	Characterized mainly by the structure
4	<p>The requirements of category B and proven safety principle specifications must be applied. Safety-related parts must be designed to meet the following requirements:</p> <ul style="list-style-type: none"> • Any single defect (fault) in a part must not cause any loss of the safety function. • If a single defect (fault) occurs, it must be detected when or before the next operation request is made to the safety function. If single defects (faults) cannot be detected, the accumulation of defects (faults) must not cause any loss of the safety function. 	<ul style="list-style-type: none"> • The safety function always operates when a single defect (fault) occurs. • Each single defect (fault) is eventually detected to prevent the loss of the safety function. 	



NOTE: The system manufacturer is responsible for selecting the level of risk factors in accordance with EN954-1. (Stop categories are defined by EN60204-1.)

Wiring Examples

The examples of wiring shown below are based on the three stop categories compliant with European Machinery Directive EN60204-1.

- Category 0: (Uncontrolled) stopping by immediate removal of power to machine actuators
- Category 1: Stopping by removal of power after controlled stopping with power to machine actuators retained
- Category 2: Controlled stopping with power to machine actuators retained



NOTE: The Safe Stop function must be activated at least once a year for preventive maintenance purposes.



NOTE: Before preventive maintenance, the machine must be turned off. If the power supply to the motor is not turned off during testing, the Safe Stop function will not operate. In such case, the inverter must be replaced.

The examples of wiring below are intended to implement the Safe Stop function through safety input of the EMR signal by the method complying with EN954-1 Category 3.

- The emergency stop circuit is monitored via an external safety relay (safety switching device).
- One safety relay (safety switching device) can be used for multiple inverters.

Example with sourcing logic

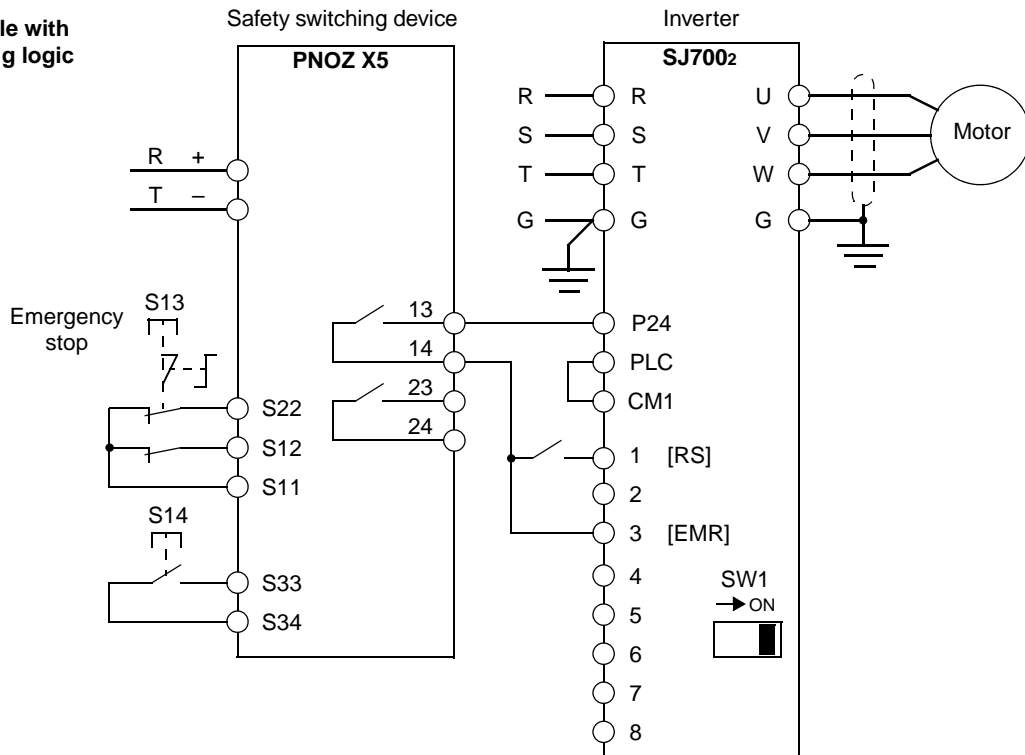

Example with sinking logic

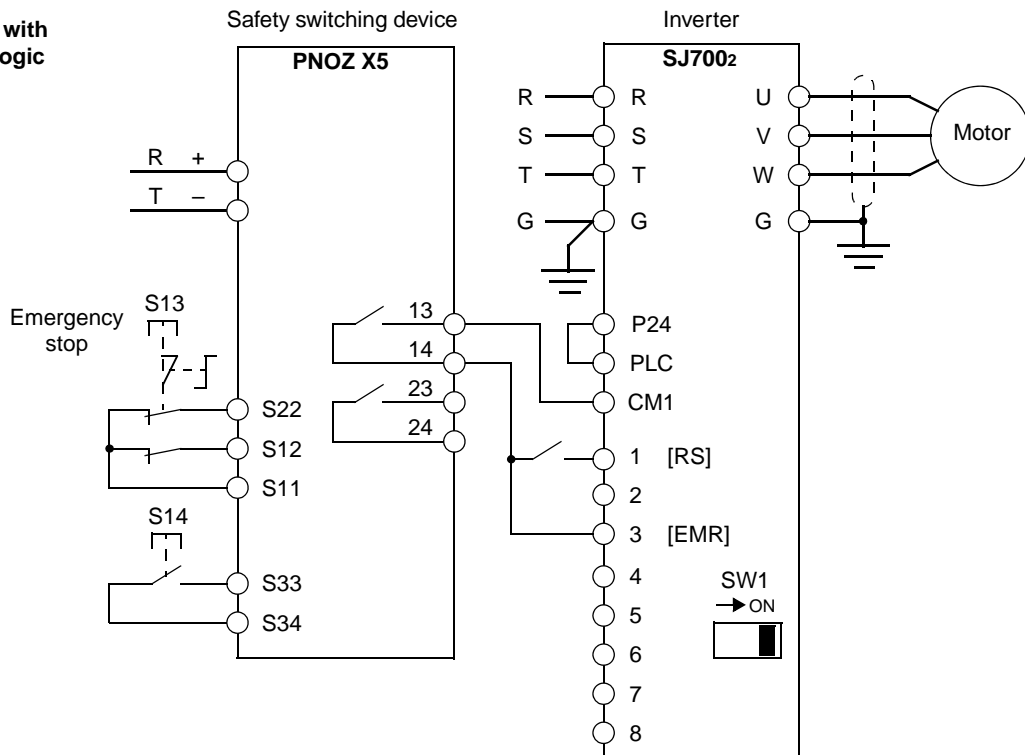

NOTE: The safety relay (safety switching device) used in these examples is the PNOZ X5 made by Pilz. Use a safety switching device equivalent to the PNOZ X5.

- S13 Emergency stop button – Switches the inverter into safe stop mode and the motor into free-running status
- S14 Start/stop button – Switches the inverter into safe stop mode by [EMR] signal input to a digital input terminal and sets the motor into free-running status. (This operation corresponds to EN60204-1 Stop Category 0.)
- Safe stop mode continues as long as the [EMR] signal is input or until the [RS] signal is input even after the [EMR] signal is canceled.
- To use the inverter for an application in which a mechanical brake (such as a crane or elevator) must be controlled, the safety output from an external safety relay must be serially connected to the brake control circuit.



NOTE: The cables used for safety relay wiring, the EMR signal, and RS signal must be shielded coaxial cables, such as type RG174/U complying with MIL-C17 (made by LAPP) or KX3B complying with NF C 93-550. Each cable must be 2.8 mm in outer diameter and 2 m or less in length. The cable shielding must be grounded.



NOTE: Every inductor-related device, such as a relay or contactor, must have an over-voltage protection circuit.

Configuring Drive Parameters



3

In This Chapter....

page

— Choosing a Programming Device	2
— Using Keypad Devices	3
— “D” Group: Monitoring Functions	6
— “F” Group: Main Profile Parameters	9
— “A” Group: Standard Functions	10
— “B” Group: Fine-Tuning Functions	30
— “C” Group: Intelligent Terminal Functions	50
— “H” Group: Motor Constants Functions	66
— “P” Group: Expansion Card Functions	69
— “U” Group: User-selectable Menu Functions	74
— Programming Error Codes	75

Choosing a Programming Device

Introduction

Hitachi variable frequency drives (inverters) use the latest electronics technology for getting the right AC waveform to the motor at the right time. The benefits are many, including energy savings and higher machine output or productivity. The flexibility required to handle a broad range of applications has required ever more configurable options and parameters—inverters are now a complex industrial automation component. And this can make a product seem difficult to use, but the goal of this chapter is to make this easier for you.

As the powerup test in Chapter 2 demonstrated, you do not have to program very many parameters to run the motor. In fact, most applications would benefit only from programming just a few, specific parameters. This chapter will explain the purpose of each set of parameters, and help you choose the ones that are important to your application.

If you are developing a new application for the inverter and a motor, finding the right parameters to change is mostly an exercise in optimization. Therefore, it is okay to begin running the motor with a loosely tuned system. By making specific, individual changes and observing their effects, you can achieve a finely tuned system. And, the SJ7002 Series inverters have a built-in auto-tuning algorithm to set certain motor parameters.

The front panel keypad is the first and best way to get to know the inverter's capabilities. Every function or programmable parameter is accessible from the keypad. All keypads have the same basic layout, but with different features. The OPE-SRE has a potentiometer knob for frequency setting input. The SRW-0EX Read/write Copy Unit has the ability to upload (copy) or download (write) all inverter parameter data to/from memory in the copy unit itself. This unit is useful in transferring one inverter's settings to another.

The following table shows various programming options, the features unique to each device, and the cables required.

Device	Part Number	Parameter Access	Parameter setting storage	Cables (for optional external mounting)	
				Part number	Length
Inverter keypad, U.S. version	OPE-SRE	Monitor and program	EEPROM in inverter	ICS-1	1 meter
				ICS-3	3 meters
Inverter keypad, European version	OPE-S	Monitor and program	EEPROM in inverter	Use same two cables as above	
Read/write Copy Unit with Keypad	SRW-0EX	Monitor and program; read or write all data	EEPROM in inverter or in copy unit	Use same two cables as above	



TIP: Other special-purpose keypads are available, such as ones to serve the needs of the HVAC market (heating, ventilating & air conditioning). Please contact your Hitachi distributor for details.

Inverter Programming Keypads

Using Keypad Devices

Inverter Front Panel Keypad

The SJ7002 Series inverter front keypad contains all the elements for both monitoring and programming parameters. The keypad layout (OPE-SRE) is shown below. All other programming devices for the inverter have a similar key arrangement and function.

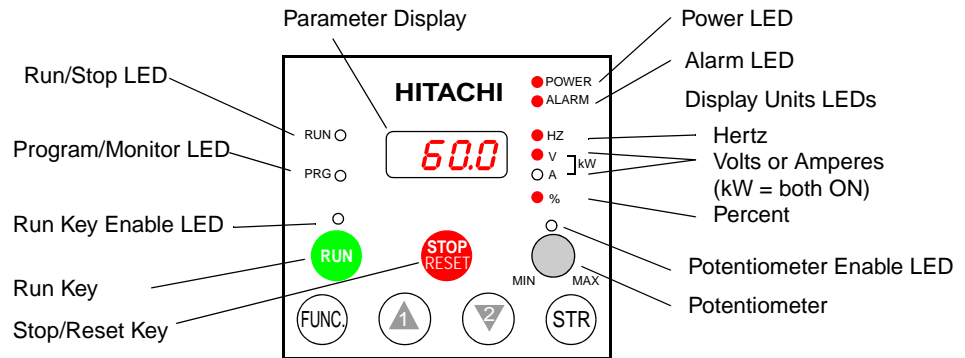

Key and Indicator Legend

- **Run/Stop LED** – ON when the inverter output is ON and the motor is developing torque, and OFF when the inverter output is OFF (Stop Mode).
- **Program/Monitor LED** – This LED is ON when the inverter is ready for parameter editing (Program Mode). It is normally OFF when the parameter display is monitoring data (Monitor Mode). However, the PRG LED will be ON whenever you are monitoring the value of parameter D001. (When the keypad is enabled as the frequency source via A001=02, you can edit the inverter frequency directly from D001 monitor display by using the Up/Down keys.)
- **Run Key** – Press this key to run the motor (the Run Enable LED must be ON first). Parameter F004, Keypad Run Key Routing, determines whether the Run key generates a Run FWD or Run REV command.
- **Run Key Enable LED** – is ON when the inverter is ready to respond to the Run key, OFF when the Run key is disabled.
- **Stop/Reset Key** – Press this key to stop the motor when it is running (uses the programmed deceleration rate). This key will also reset an alarm that has tripped.
- **Potentiometer** (OPE-SRE only) – allows an operator to directly set the motor speed when the potentiometer is enabled for output frequency control
- **Potentiometer Enable LED** – ON when the potentiometer is enabled for value entry (OPE-SRE only).
- **Parameter Display** – a 4-digit, 7-segment display for parameters and function codes.
- **Display Units: Hertz/Volts/Amperes/kW/%** – These LEDs indicate the units associated with the parameter display. When the display is monitoring a parameter, the appropriate LED is ON. In the case of kW units, both Volts and Amperes LEDs will be ON. An easy way to remember this is that $kW = (V \times A)/1000$.
- **Power LED** – This LED is ON when the power input to the inverter is ON.
- **Alarm LED** – This LED is ON when an alarm condition has tripped the inverter. Clearing the alarm will turn this LED OFF again. See Chapter 6 for details on clearing alarms.
- **Function Key** – This key is used to navigate through the lists of parameters and functions for setting and monitoring parameter values.
- **Up/Down (▲, ▼) Keys** – Use these keys to alternately move up or down the lists of parameter and functions shown in the display, and increment/decrement values.
- **Store (Ⓢ) Key** – When the unit is in Program Mode and the operator has edited a parameter value, press the Store key to write the new value to the EEPROM. This parameter is then displayed at powerup by default. If you want to change the powerup default, navigate to a new parameter value and press the Store key.

Keypad Navigational Map

Whether you use the keypad on the inverter or the read-write copy unit, each navigates the same way. The diagram below shows the basic navigational map of parameters and functions.

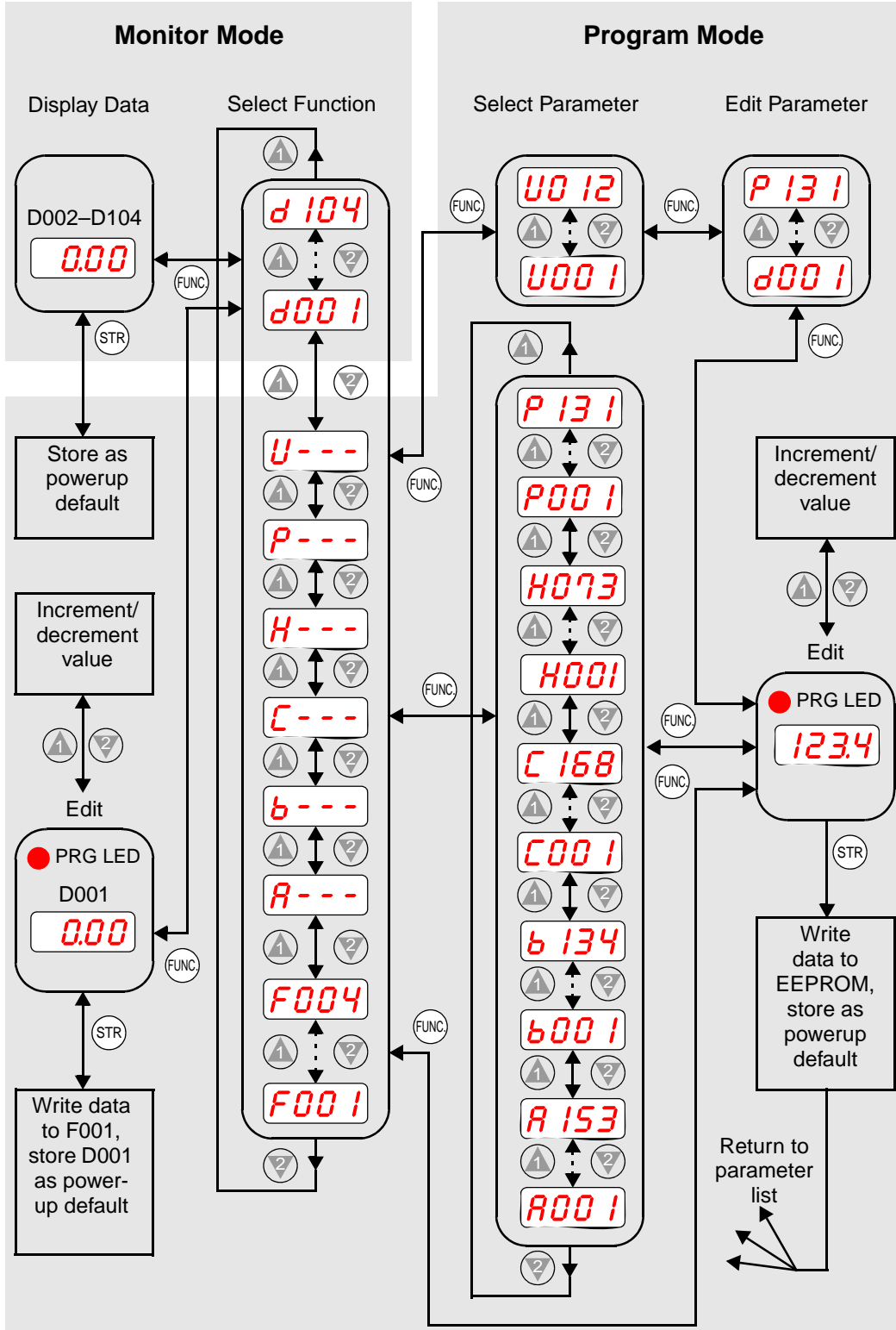

Configuring Drive Parameters



NOTE: The inverter 7-segment display shows lower case “b” and “d”, meaning the same as the upper case letters “B” and “D” used in this manual (for uniformity “A to F”).

Operational Modes

The RUN and PGM LEDs tell just part of the story; Run Mode and Program Modes are independent modes, not opposite modes. In the state diagram to the right, Run alternates with Stop, and Program Mode alternates with Monitor Mode. This is a very important ability, for it shows that a technician can approach a running machine and change some parameters without shutting down the machine.

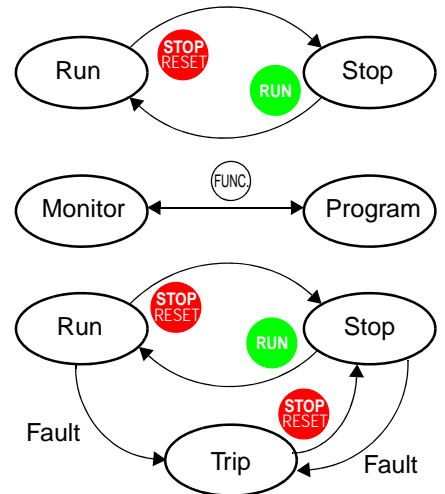

The occurrence of a fault during operation will cause the inverter to enter the Trip Mode as shown. An event such as an output overload will cause the inverter to exit the Run Mode and turn OFF its output to the motor. In the Trip Mode, any request to run the motor is ignored. You must clear the error by pressing the Stop/Reset switch. See [“Monitoring Trip Events, History, & Conditions” on page 6-5.](#)

Run Mode Edits

The inverter can be in Run Mode (inverter output is controlling motor) and still allow you to edit certain parameters. This is useful in applications that must run continuously, yet need some inverter parameter adjustment.

The parameter tables in this chapter have a column titled “Run Mode Edit.” An Ex mark ✘ means the parameter cannot be edited; a Check mark ✓ means the parameter can be edited. You’ll notice in the table example to the right the two adjacent marks: “✘ ✓”. The two marks (that can also be “✘ ✘” or “✓ ✓”) correspond to these levels of access to editing:

	Run Mode Edit	
	Lo Hi	
	✘ ✓	

- Low-access level to Run Mode edits (indicated by *left-most* mark)
- High-access level to Run Mode edits (indicated by *right-most* mark)

The Software Lock Setting (parameter B031) determines the particular access level that is in effect during Run Mode and access in other conditions, as well. It is the responsibility of the user to choose a useful and safe software lock setting for the inverter operating conditions and personnel. Please refer to [“Software Lock Mode” on page 3-38](#) for more information.

Control Algorithms

The motor control program in the SJ7002 inverter has several sinusoidal PWM switching algorithms. The intent is that you select the best algorithm for the motor characteristics in your application. Each algorithm generates the frequency output in a unique way. Once configured, the algorithm is the basis for other parameter settings as well (see [“Torque Control Algorithms” on page 3-14](#)). Therefore, choose the best algorithm early in your application design process.

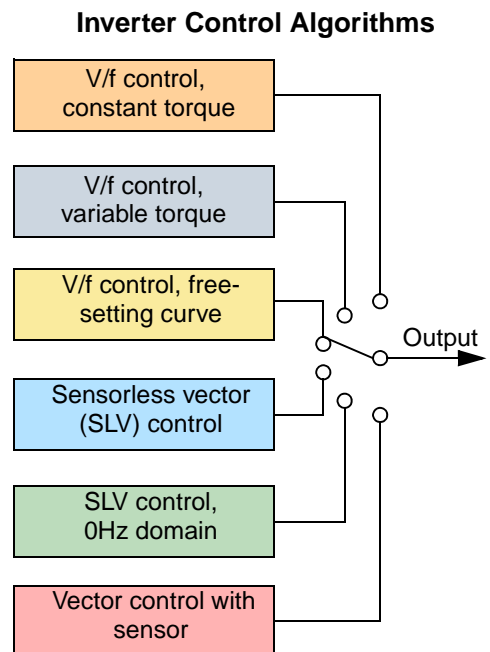

Configuring Drive Parameters

“D” Group: Monitoring Functions

Parameter Monitoring Functions

You can access important system parameter values with the “D” Group monitoring functions, whether the inverter is in Run Mode or Stop Mode. After selecting the function code number for the parameter you want to monitor, press the Function key once to show the value on the display. In Functions D005 and D006 the intelligent terminals use individual segments of the display to show ON/OFF status.

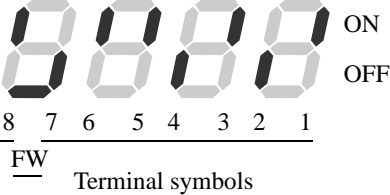
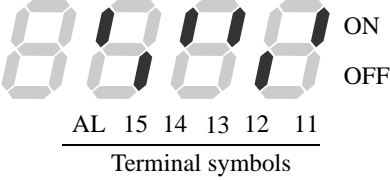
Func. Code	Name	Description	Units
D001	Output frequency monitor	Real-time display of output frequency to motor, from 0.0 to 400.0 Hz	0.0 to 400.0 Hz
D002	Output current monitor	Filtered display of output current to motor (100 mS internal filter time constant)	A
D003	Rotation direction monitor	Three different indications:  Forward Stop Reverse	—
D004	Process variable (PV), PID feedback monitor	Displays the scaled PID process variable (feedback) value (A75 is scale factor)	—
D005	Intelligent input terminal status	Displays the state of the intelligent input terminals:  Terminal symbols	—
D006	Intelligent output terminal status	Displays the state of the intelligent output terminals:  Terminal symbols	—
D007	Scaled output frequency monitor	Displays the output frequency scaled by the constant in B0086. Decimal point indicates range: XX.XX 0.00 to 99.99 XXX.X 100.0 to 999.9 XXXX. 1000 to 9999 XXXX 10000 to 99990	User-defined
D008	Actual frequency monitor	Displays the actual shaft speed of the motor, converted to frequency	Hz
D009	Torque command monitor	Displays the level of the torque command when the inverter is set to torque control mode	%
D010	Torque bias monitor	Displays the level of the torque bias, if enabled, when the inverter is in vector control mode with feedback	%

Func. Code	Name	Description	Units
D012	Torque monitor	Estimated output torque value, range is -300.0 to +300.0%	%
D013	Output voltage monitor	Voltage of output to motor, range is 0.0 to 600.0V	VAC
D014	Power monitor	Input power to inverter, range is 0.0 to 999.9	kW
D015	Cumulative power monitor	Displays cumulative input power to inverter; B079 selects the multiplier for units. Range is 0.0 to 999.9, 1000 to 9999, or 100 to 999	kW/h
D016	Cumulative operation RUN time monitor	Displays total time the inverter has been in RUN mode in hours. Range is 0 to 9999 / 1000 to 9999 / 100 to 999 (10,000 to 99,900) hrs.	hours
D017	Cumulative power-on time monitor	Displays total time the inverter has had input power (ON) in hours. Range is: 0 to 9999 / 100.0 to 999.9 / 1000 to 9999 / 100 to 999 hrs.	hours
D018	Heat sink temperature monitor	Displays the temperature of the inverter's heat sink	°C
D019	Motor temperature monitor	Displays motor internal temperature (requires an NTC thermistor installed in the motor and connected to [TH] and [CM1]).	°C
D022	Component life monitor	Displays estimated life status of DC bus capacitors and cooling fans	—
D023	Program counter	Displays the current program step being executed when the inverter is operating under the control of an EZ Sequence program	Programs
D024	Program number counter	Displays the EZ Sequence program identification number, if defined in the program, when a program is loaded in the inverter	Program
D025	User monitor 0	Displays state of internal EZ Sequence register User Monitor 0	—
D026	User monitor 1	Displays state of internal EZ Sequence register User Monitor 1	—
D027	User monitor 2	Displays state of internal EZ Sequence register User Monitor 2	—
D028	Pulse counter	Displays accumulated pulse count of [PCNT] intelligent input terminal (option code 74)	Pulses
D029	Position setting monitor	Displays absolute position command for motor shaft in absolute position control mode	Pulses
D030	Position feedback monitor	Displays absolute position of motor shaft when in absolute position control mode	Pulses
D102	DC voltage monitoring	Displays the DC Bus voltage	V
D103	BRD load factor monitoring	Displays the running average Dynamic Braking usage ratio (%ED)	%
D104	Electronic thermal overload monitoring	Displays the motor electronic thermal overload estimated temperature ratio. If the value reaches 100%, the inverter will trip (E05).	%

Trip Event and Programming Error Monitoring

The trip event and history monitoring feature lets you cycle through related information using the keypad. See ["Monitoring Trip Events, History, & Conditions"](#) on page 6-5 for more details.

Programming errors generate an error code that begins with the special **H** character. See ["Programming Error Codes"](#) on page 3-75 for more information.

Func. Code	Name	Description	Units
D080	Trip Counter	Number of trip events	—
D081 to D086	Trip monitor 1 to 6	Displays trip event information	—
D090	Programming error monitor	Displays programming error code	—

“F” Group: Main Profile Parameters

The basic frequency (speed) profile is defined by parameters contained in the “F” Group as shown to the right. The output frequency is set in Hz, but acceleration and deceleration are specified seconds (the time to ramp from zero to maximum frequency, or from maximum frequency to zero). The motor direction keypad parameter determines whether the keypad Run key produces a FW or RV command. This parameter does not affect the [FW] terminal or [RV] intelligent terminal function, which you configure separately.

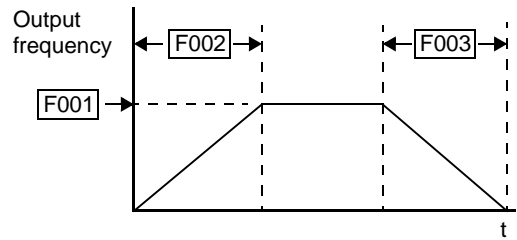

Acceleration 1 and Deceleration 1 are the standard default accel and decel values for the main profile. Accel and decel values for an alternative profile are specified by using parameters Ax92 through Ax93. The motor direction selection (F004) determines the direction of rotation as commanded only from the keypad. This setting applies to any motor profile (1st, 2nd, or 3rd) in use at a particular time.

Func. Code	Name/Description	Keypad		Range and Settings	Defaults			Run Mode Edit Lo Hi
		SRW	OPE		FEF2 FE2 (EU)	FUF2 FU2 (USA)	FF2 F2 (Jpn)	
F001	Output frequency setting	—	—	0 to 400 (Hz)	0.00	0.00	0.00	✓ ✓
	Standard default target frequency that determines constant motor speed							
F002	Acceleration (1) time setting	—	—	0.01 to 3600 (seconds)	30.0	30.0	30.0	✓ ✓
	Standard default acceleration							
F202	Acceleration (1) time setting, 2nd motor	—	—	0.01 to 3600 (seconds)	30.0	30.0	30.0	✓ ✓
	Standard default acceleration, 2nd motor							
F302	Acceleration (1) time setting, 3rd motor	—	—	0.01 to 3600 (seconds)	30.0	30.0	30.0	✓ ✓
	Standard default acceleration, 3rd motor							
F003	Deceleration (1) time setting	—	—	0.01 to 3600 (seconds)	30.0	30.0	30.0	✓ ✓
	Standard default deceleration							
F203	Deceleration (1) time setting, 2nd motor	—	—	0.01 to 3600 (seconds)	30.0	30.0	30.0	✓ ✓
	Standard default deceleration, 2nd motor							
F303	Deceleration (1) time setting, 3rd motor	—	—	0.01 to 3600 (seconds)	30.0	30.0	30.0	✓ ✓
	Standard default deceleration, 3rd motor							
F004	Keypad Run key routing	FW	00	Forward	00	00	00	✗ ✗
		RV	01	Reverse				

“A” Group: Standard Functions

Basic Parameter Settings

These settings affect the most fundamental behavior of the inverter—the outputs to the motor. The frequency of the inverter’s AC output determines the motor speed. You may select from three different sources for the reference speed. During application development you may prefer using the potentiometer, but you may switch to an external source (control terminal setting) in the finished application, for example.

The base frequency and maximum frequency settings interact according to the graph below (left). The inverter output operation follows the constant V/f curve until it reaches the full-scale output voltage. This initial straight line is the constant-torque part of the operating characteristic. The horizontal line over to the maximum frequency serves to let the motor run faster, but at a reduced torque. This is the constant-horsepower part of the characteristic. If you want the motor to output constant torque over its entire operating range (limited to the motor nameplate voltage and frequency rating), then set the base frequency and maximum frequency equal as shown (below right).

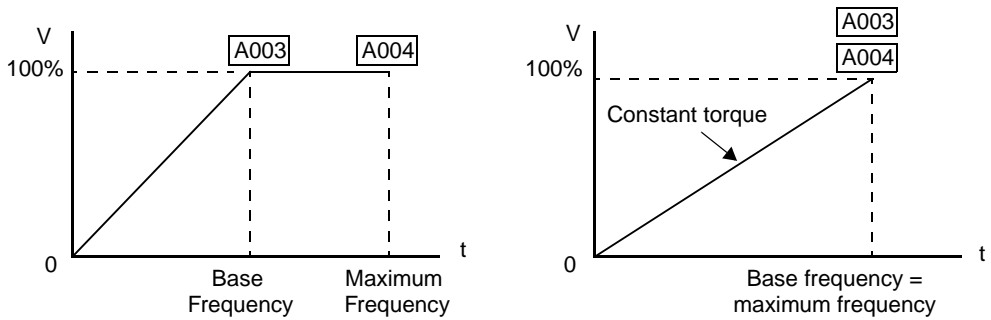

NOTE: The “2nd motor” and “3rd motor” settings in the tables in this chapter store an alternate set of parameters for additional motors. The inverter can use the 1st, 2nd, or 3rd set of parameters to generate the output frequency to the motor. See [“Configuring the Inverter for Multiple Motors” on page 4-76.](#)

Func. Code	Name/ Description	Keypad		Range and Settings	Defaults			Run Mode Edit Lo Hi
		SRW	OPE		FEF2 FE2 (EU)	FUF2 FU2 (USA)	FF2 F2 (Jpn)	
A001	Frequency source setting	VR	00	Keypad potentiometer	01	01	02	x x
		TRM	01	Control terminal				
		REM	02	Function F001 setting				
		RS485	03	RS485 serial command				
		OP1	04	Expansion board 1				
		OP2	05	Expansion board 2				
		PLS	06	Pulse train input				
		PRG	07	Easy sequence				
	MATH	10	Calculate function input					
A002	Run command source setting	TRM	01	Input terminal [FW] or [RV] (assignable)	01	01	02	x x
		REM	02	Run key on keypad of digital operator				
		RS485	03	RS485 serial command				
		OP1	04	Start/Stop, expansion card #1				
		OP2	05	Start/Stop, expansion card #2				

Func. Code	Name/Description	Keypad		Range and Settings	Defaults			Run Mode Edit Lo Hi
		SRW	OPE		FEF2 FE2 (EU)	FUF2 FU2 (USA)	FF2 F2 (Jpn)	
A003	Base frequency setting			30. to maximum frequency (Hz)	50.	60.	60.	✕ ✕
A203	Base frequency setting, 2nd motor			30. to maximum frequency (Hz)	50.	60.	60.	✕ ✕
A303	Base frequency setting, 3rd motor			30. to maximum frequency (Hz)	50.	60.	60.	✕ ✕
A004	Maximum frequency setting			30. to 400. (Hz)	50.	60.	60.	✕ ✕
A204	Maximum frequency setting, 2nd motor			30. to 400. (Hz)	50.	60.	60.	✕ ✕
A304	Maximum frequency setting, 3rd motor			30. to 400. (Hz)	50.	60.	60.	✕ ✕

NOTE: Intelligent terminals [OPE] (option code 31) or [F-TM] (option code 51) can override settings A001 and A002 when either terminal is ON and the operation commands for that terminal is enabled.

NOTE: When using a remote operator (SRW) to operate the inverter, the REMT (remote) key allows you to enter the frequency setting and operation commands remotely.

NOTE: When the DeviceNet option board (SJ-DN) is installed, you may keep the A002 default setting because the Run Command Source is automatically set via DeviceNet. Otherwise, only use settings A002 = 01, 02, or 03.



NOTE: The base frequency must be less than or equal to the maximum frequency (ensure that $A003 \leq A004$).

Analog Input and Miscellaneous Settings

The inverter has the capability to accept external analog inputs that can command the output frequency to the motor. Signals including voltage input (0 to +10V) at terminal [O], bipolar input (-10 to +10V) at terminal [O2], and current input (4 to 20mA) at terminal [OI] are available. Terminal [L] serves as signal ground for the three analog inputs. The analog input settings adjust the curve characteristics between the analog input and the frequency output.

Adjusting [O-L] characteristics – In the graph to the right, A013 and A014 select the active portion of the input voltage range. Parameters A011 and A012 select the start and end frequency of the converted output frequency range, respectively. Together, these four parameters define the major line segment as shown. When the line does not begin at the origin (A011 and A013 > 0), then A015 defines whether the inverter outputs 0Hz or the A011-specified frequency when the analog input value is less than the A013 setting. When the input voltage is greater than the A014 ending value, the inverter outputs the ending frequency specified by A012.

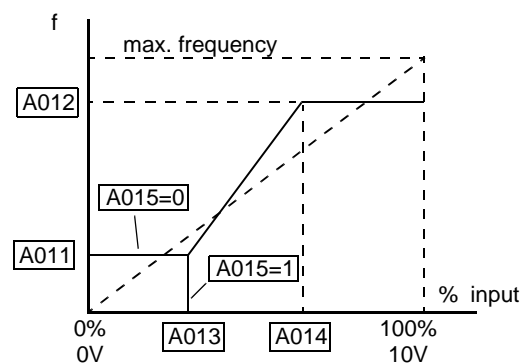

Adjusting [OI-L] characteristics – In the graph to the right, A103 and A104 select the active portion of the input current range. Parameters A101 and A102 select the start and end frequency of the converted output frequency range, respectively. Together, these four parameters define the major line segment as shown. When the line does not begin at the origin (A101 and A103 > 0), then A105 defines whether the inverter outputs 0Hz or the A101-specified frequency when the analog input value is less than the A103 setting. When the input voltage is greater than the A104 ending value, the inverter outputs the ending frequency specified by A102.

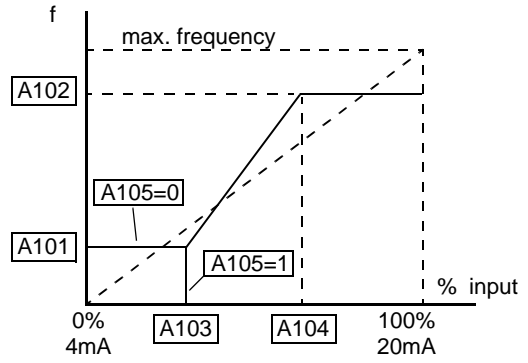

Adjusting [O2-L] characteristics – In the graph to the right, A113 and A114 select the active portion of the input voltage range. Parameters A111 and A112 select the start and end frequency of the converted output frequency range, respectively. Together, these four parameters define the major line segment as shown. When the input voltage is less than the A113 input starting value, the inverter outputs the starting frequency specified by A111. When the input voltage is greater than the A114 ending value, the inverter outputs the ending frequency specified by A112.

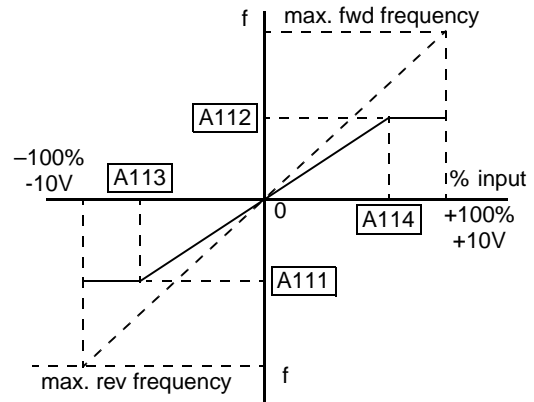

Configuring Drive Parameters

Func. Code	Name/Description	Keypad		Range and Settings	Defaults			Run Mode Edit Lo Hi
		SRW	OPE		FEF2 FE2 (EU)	FUF2 FU2 (USA)	FF2 F2 (Jpn)	
A005	[AT] selection	0/O1	00	Select between [O] and [OI] at [AT]	00	00	00	X X
		0/O2	01	Select between [O] and [O2] at [AT]				
		0/VR	02	Select between [O] and keypad pot.				
		0I/VR	03	Select between [OI] and keypad pot.				
		02/VR	04	Select between [O2] and keypad pot.				
A006	[O2] selection	02	00	No summing, [O2] and [OI]	03	03	03	X X
		0/O1-P	01	Sum of [O2] and [OI], neg. sum (reverse speed reference) inhibited				
		0/O1-PM	02	Sum of [O2] and [OI], neg. sum (reverse speed reference) allowed				
		0FF	03	Disable [O2] input				
A011	[O]-[L] input active range start frequency			0.00 to 99.99, 100.0 to 400.00 (Hz); model -4000HFx2 is 0.00 to 120.00 (Hz)	0.00	0.00	0.00	X ✓
	The output frequency corresponding to the voltage input range starting point							
A012	[O]-[L] input active range end frequency			0.00 to 99.99, 100.0 to 400.00 (Hz); model -4000HFx2 is 0.00 to 120.00 (Hz)	0.00	0.00	0.00	X ✓
	The output frequency corresponding to the voltage input range ending point							

Func. Code	Name/Description	Keypad		Range and Settings	Defaults			Run Mode Edit Lo Hi
		SRW	OPE		FEF2 FE2 (EU)	FUF2 FU2 (USA)	FF2 F2 (Jpn)	
A013	[O]-[L] input active range start voltage			0. to [O]-[L] input active range end voltage (%)	0.	0.	0.	✗ ✓
	The starting point for the voltage input range							
A014	[O]-[L] input active range end voltage			[O]-[L] input active range start voltage to 100. (%)	100.	100.	100.	✗ ✓
	The ending point for the voltage input range							
A015	[O]-[L] input start frequency enable	0-EXS	00	Use A011 start value	01	01	01	✗ ✓
		0HZ	01	Use 0 Hz				
A016	External frequency filter time constant			n = 1 to 30 (where n = number of samples for average); 31=500ms filter	8.	8.	8.	✗ ✓
A017	Easy sequence function enable	OFF	00	Disable	00	00	00	✗ ✗
		ON	01	Enable				

Multi-speed and Jog Frequency Settings

The SJ7002 inverter has the capability to store and output up to 16 preset frequencies to the motor (A020 to A035). As in traditional motion terminology, we call this *multi-speed profile* capability. These preset frequencies are selected by means of digital inputs to the inverter. The inverter applies the current acceleration or deceleration setting to change from the current output frequency to the new one. The first multi-speed setting is duplicated for the second motor settings (the remaining 15 multi-speeds apply only to the first motor).

The jog speed setting is used whenever the Jog command is active. The jog speed setting range is arbitrarily limited to 10 Hz to provide safety during manual operation. The acceleration to the jog frequency is instantaneous, but you can choose from six modes for the best method for stopping the jog operation.

Func. Code	Name/Description	Keypad		Range and Settings	Defaults			Run Mode Edit Lo Hi
		SRW	OPE		FEF2 FE2 (EU)	FUF2 FU2 (USA)	FF2 F2 (Jpn)	
A019	Multi-speed operation selection	BINARY	00	Binary; up to 16-stage speed using 4 intelligent terminals	00	00	00	✗ ✗
		BIT	01	Single-bit; up to 8-stage speed using 7 intelligent terminals				
A020	Multi-speed frequency setting			0 to 360 (Hz) A020 = Speed 0 (1st motor)	0.00	0.00	0.00	✓ ✓
	Defines the first speed of a multi-speed profile							
A220	Multi-speed frequency setting, 2nd motor			0 to 360 (Hz) A220 = Speed 0 (2nd motor)	0.00	0.00	0.00	✓ ✓
	Defines the first speed of a multi-speed profile for 2nd motor							
A320	Multi-speed frequency setting, 3rd motor			0 to 360 (Hz) A320 = Speed 0 (3rd motor)	0.00	0.00	0.00	✓ ✓
	Defines the first speed of a multi-speed profile for 3rd motor							
A021 to A035	Multi-speed frequency settings (for multiple motors)			0 to 360 (Hz) A021 = Speed 1... A035 = Speed 15	0.00	0.00	0.00	✓ ✓
	Defines 15 additional speeds							

Func. Code	Name/Description	Keypad		Range and Settings	Defaults			Run Mode Edit Lo Hi
		SRW	OPE		FEE2 FE2 (EU)	FUF2 FU2 (USA)	FF2 F2 (Jpn)	
A038	Jog frequency setting			0.5 to 9.99 (Hz)	1.00	1.00	1.00	✓✓
	Defines limited speed for jog							
A039	Jog stop mode	FRS	00	Free-run stop, jogging disabled during motor run	00	00	00	✗✓
	Defines how end of jog stops the motor	DEC	01	Controlled deceleration, jogging disabled during motor run				
		DB	02	DC braking to stop, jogging disabled during motor run				
		R-FRS	03	Free-run stop, jogging always enabled				
		R-DEC	04	Controlled deceleration, jogging always enabled				
		R-DB	05	DC braking to stop, jogging always enabled				

Configuring Drive Parameters

Torque Control Algorithms

The inverter generates the motor output according to the V/f algorithm or the sensorless vector control algorithm. Parameter A044 selects the inverter torque control algorithm for generating the frequency output, as shown in the diagram to the right (A244 and A344 for 2nd and 3rd motors, respectively). The factory default is 00 (constant torque V/f control).

Review the following descriptions to help you choose the best torque control algorithm for your application.

- The built-in V/f curves are oriented toward developing constant torque or variable torque characteristics (see graphs below).
- The free-setting curve provides an even more flexible characteristic, but it requires more parameter settings.
- Sensorless vector control calculates an ideal torque vector based on current motor position, winding currents, and so on. It is a more robust control method than the V/f control methods. However, it is more dependent on actual motor parameters and will require you to set these values carefully or to perform the auto-tuning procedure (see ["Auto-tuning of Motor Constants"](#) on page 4-71) to obtain optimum performance.
- Sensorless vector control, 0Hz domain increases the low-speed torque performance (0–2.5Hz) via an advanced Hitachi torque control algorithm. However, you will need to size the inverter for one frame size larger than the motor for proper operation.
- Vector control with sensor requires expansion card SJ-FB encoder feedback board and a motor shaft encoder. Choose this method when precise position/velocity control is required.

Inverter Torque Control Algorithms

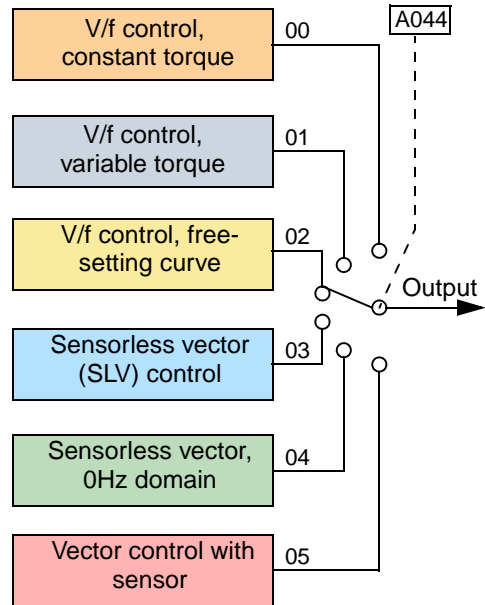

Constant and Variable Torque – The graph below (left) shows the constant torque characteristic from 0Hz to the base frequency A003. The voltage remains constant for output frequencies higher than the base frequency.

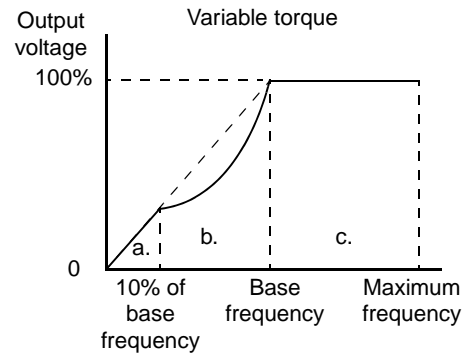
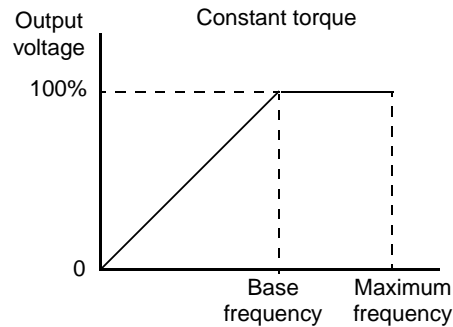

The graph above (right) shows the general characteristic for variable torque. The curve may be best described in three sections, as follows:

- a. The range from 0Hz to 10% of the base frequency is the constant torque characteristic. For example, a base frequency of 60Hz ends the constant torque characteristic segment at 6Hz.
- b. The range from 10% of the base frequency to the base frequency is the variable (reduced) torque characteristic. The voltage is output in the curve of frequency to the 1.7 power.
- c. After reaching the base frequency, the characteristic maintains a constant output voltage for higher frequencies.

Using parameter A045 you can modify the voltage gain of the inverter. This is specified as a percentage of the full-scale setting AVR (Automatic Voltage Regulation) in parameter A082. The gain can be set from 20% to 100%. It must be adjusted in accordance with the motor specifications.

Torque Boost – The Constant and Variable Torque algorithms feature an adjustable *torque boost* curve. When the motor load has a lot of inertia or starting friction, you may need to increase the low frequency starting torque characteristics by boosting the voltage above the normal V/f ratio (shown at right). The boost is applied from zero to 1/2 the base frequency. You set the breakpoint of the boost (point A on the graph) by using parameters A042 and A043. The manual boost is calculated as an addition to the standard straight V/f line (constant torque curve).

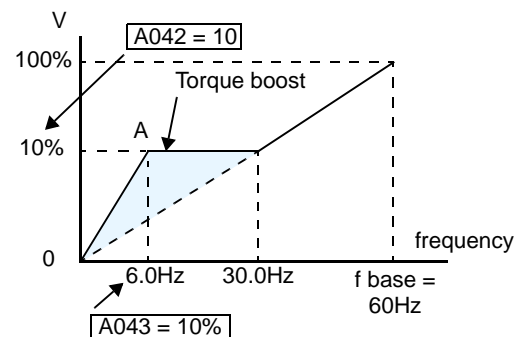

Be aware that running the motor at a low speed for a long time can cause motor overheating. This is particularly true when manual torque boost is ON or if the motor relies on a built-in fan for cooling.



NOTE: Manual torque boost applies only to constant torque (A044=00) and variable torque (A044=01) V/f control.



NOTE: The motor stabilization parameter H006 is effective for constant torque (A044=00) and variable torque (A044=01) V/f control.

V/f Free-setting – The free-setting V/f inverter mode of operation uses voltage and frequency parameter pairs to define seven points on a V/f graph. This provides a way to define a multi-segment V/f curve that best suits your application.

The frequency settings do require that $F1 \leq F2 \leq F3 \leq F4 \leq F5 \leq F6 \leq F7$; their values must have this ascending order relationship. However, the voltages V1 to V7 may either increase or decrease from one to the next. The example to the right shows the definition of a complex curve by following the setting requirements.

Free-setting f7 (B112) becomes the maximum frequency of the inverter. Therefore, we recommend setting f7 first, since the initial value of all default frequencies f1–f7 is 0Hz.

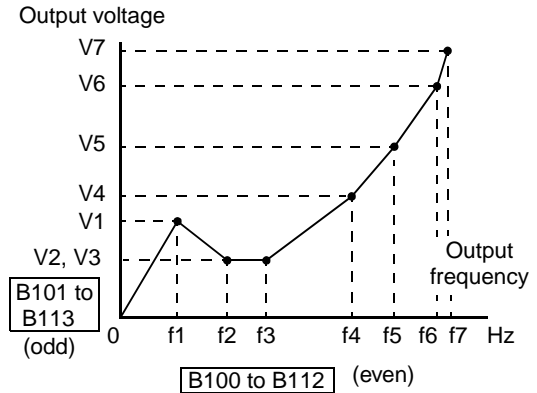

NOTE: The using of V/f free-setting operation specifies parameters that override (make invalid) certain other parameters. The parameters that become invalid are torque boost (A041/A241), base frequency (A003/A203/A303), and maximum frequency (A004/A204/A304). In this case, we recommend leaving their settings at the factory default values.

The V/f free-setting endpoint f7/V7 parameters must stay within the more basic inverter limits in order for the specified free-setting characteristic curve to be achieved. For example, the inverter cannot output a higher voltage than the input voltage or the AVR setting voltage (Automatic Voltage Regulation), set by parameter A082. The graph to the right shows how the inverter input voltage would clip (limit) the characteristic curve if exceeded.

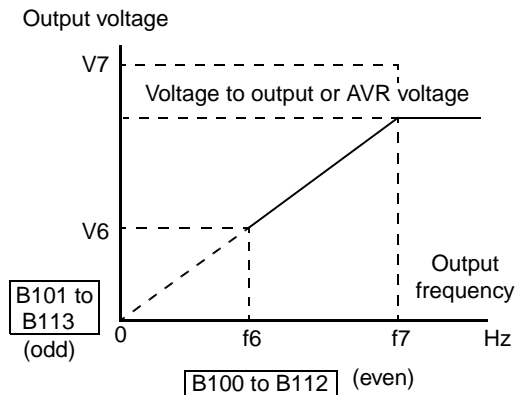

Sensorless Vector Control and, Sensorless Vector Control, 0Hz Domain – These advanced torque control algorithms improve the torque performance at very low speeds:

- Sensorless Vector Control – improved torque control at output frequencies down to 0.5 Hz
- Sensorless Vector Control, 0Hz Domain – improved torque control at output frequencies from 0 to 2.5 Hz.

These low-speed torque control algorithms must be tuned to match the characteristics of the particular motor connected to your inverter. Simply using the default motor parameters in the inverter will not work satisfactorily for these control methods. Chapter 4 discusses motor/inverter size selection and how to set the motor parameters either manually or by using the built-in auto-tuning. Before using the sensorless vector control methods, please refer to ["Setting Motor Constants for Vector Control"](#) on page 4-69.

NOTE: When the inverter is in SLV (sensorless vector) mode, use B083 to set the carrier frequency greater than 2.1 kHz for proper operation.

NOTE: You must disable sensorless vector operation when two or more motors are connected (parallel operation) to the inverter.



Vector Control with Encoder Feedback – This method of torque control uses an encoder as a motor shaft position sensor. Accurate position feedback allows the inverter to close the velocity loop and provide very accurate speed control, even with variations in motor loads. To use encoder feedback you will need to add an SJ-FB Encoder Feedback Card in the inverter's expansion bay. Please refer to [“Expansion Cards” on page 5-5](#) in this manual or the SJ-FB manual for details. The following table shows the methods of torque control selection.

Func. Code	Name/Description	Keypad		Range and Settings	Defaults			Run Mode Edit Lo Hi
		SRW	OPE		FEF2 FE2 (EU)	FUF2 FU2 (USA)	FF2 F2 (Jpn)	
A041	Torque boost method selection	MANUAL	00	Manual torque boost	00	00	00	x x
		AUTO	01	Automatic torque boost				
A241	Torque boost method selection, 2nd motor	MANUAL	00	Manual torque boost	00	00	00	x x
		AUTO	01	Automatic torque boost				
A042	Manual torque boost value			0.0 to 20.0 (%)	1.0	1.0	1.0	✓ ✓
	Can boost starting torque between 0 and 20% above normal V/f curve							
A242	Manual torque boost value, 2nd motor			0.0 to 20.0 (%)	1.0	1.0	1.0	✓ ✓
	Can boost starting torque between 0 and 20% above normal V/f curve							
A342	Manual torque boost value, 3rd motor			0.0 to 20.0 (%)	1.0	1.0	1.0	✓ ✓
	Can boost starting torque between 0 and 20% above normal V/f curve							
A043	Manual torque boost frequency adjustment			0.0 to 50.0 (%)	5.0	5.0	5.0	✓ ✓
	Sets the frequency of the V/f breakpoint A in graph (top of previous page) for torque boost							
A243	Manual torque boost frequency adjustment, 2nd motor			0.0 to 50.0 (%)	5.0	5.0	5.0	✓ ✓
	Sets the frequency of the V/f breakpoint A in graph (top of previous page) for torque boost							
A343	Manual torque boost frequency adjustment, 3rd motor			0.0 to 50.0 (%)	5.0	5.0	5.0	✓ ✓
	Sets the frequency of the V/f breakpoint A in graph (top of previous page) for torque boost							
A044	V/f characteristic curve selection, 1st motor	VC	00	V/f constant torque	00	00	00	x x
	Torque control modes	VP	01	V/f variable torque				
		FREE-WF	02	V/f free-setting curve				
		SLV	03	Sensorless vector SLV				
		ØSLV	04	0Hz domain SLV				
		V2	05	Vector control with encoder feedback				
A244	V/f characteristic curve selection, 2nd motor	VC	00	V/f constant torque	00	00	00	x x
	Torque control modes	VP	01	V/f variable torque				
		FREE-WF	02	V/f free-setting curve				
		SLV	03	Sensorless vector SLV				
		ØSLV	04	0Hz domain SLV				

Func. Code	Name/Description	Keypad		Range and Settings	Defaults			Run Mode Edit Lo Hi
		SRW	OPE		FEF2 FE2 (EU)	FUF2 FU2 (USA)	FF2 F2 (Jpn)	
A344	V/f characteristic curve selection, 3rd motor	VC	00	V/f constant torque	00	00	00	xx
	Torque control modes	VP	01	V/f variable torque				
A045	V/f gain setting Sets voltage gain of the inverter			0. to 255.	100.	100.	100.	✓✓
A046	Automatic torque boost voltage gain Voltage compensation gain for automatic torque boost			0. to 255.	100.	100.	100.	✓✓
A246	Automatic torque boost voltage gain, 2nd motor Voltage compensation gain for automatic torque boost			0. to 255.	100.	100.	100.	✓✓
A047	Automatic torque boost slip gain Slip compensation gain for automatic torque boost			0. to 255.	100.	100.	100.	✓✓
A247	Automatic torque boost slip gain, 2nd motor Slip compensation gain for automatic torque boost			0. to 255.	100.	100.	100.	✓✓

DC Braking Settings

The DC braking feature can provide additional stopping torque when compared to a normal deceleration to a stop. It can also ensure the motor and load are stopped before acceleration.

When decelerating – DC braking is particularly useful at low speeds when normal deceleration torque is minimal. During deceleration, the inverter injects a DC voltage into the motor windings during deceleration below a frequency you can specify (A052). The braking power (A054) and duration (A055) can both be set. You can optionally specify a wait time before DC braking (A053), during which the motor will free run (coast).

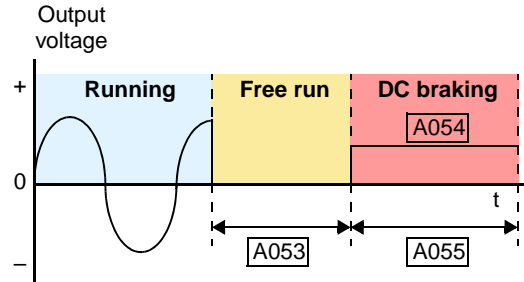

When starting – You can also apply DC braking upon the application of a Run command, specifying both the DC braking force level (A057) and the duration (A058). This will serve to stop the rotation of the motor and the load, when the load is capable of driving the motor. This effect, sometimes called “windmilling,” is common in fan applications. Often, air moving in duct work will drive the fan in a backward direction.

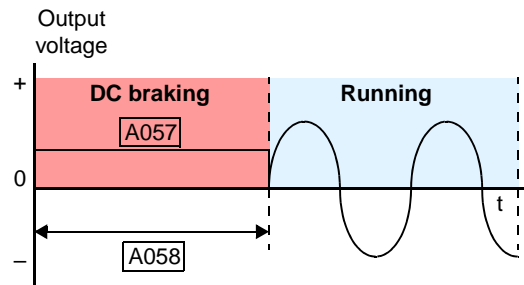

If an inverter is started into such a backward-rotating load, over-current trips can occur. Use DC braking as an “anti-windmilling” technique to stop the motor and load, and allow a normal acceleration from a stop. See also the [“Acceleration Pause Function” on page 3-21](#).

You can configure the inverter to apply DC braking at stopping only, at starting only, or both. DC braking power (0–100%) can be set separately for stopping and starting cases.

Configuring Drive Parameters

You can configure DC braking to initiate in one of two ways:

1. **Internal DC braking** – Set A051=01 to enable internal braking. The inverter automatically applies DC braking as configured (during stopping, starting, or both).
2. **External DC braking** – Configure an input terminal with option code 7 [DB] (see [“External Signal for DC Injection Braking”](#) on page 4-19 for more details). Leave A051=00, although this setting is ignored when a [DB] input is configured. The DC braking force settings (A054 and A057) still apply. However, the braking time settings (A055 and A058) do not apply (see level and edge triggered descriptions below). Use A056 to select level or edge detection for the external input.
 - a. Level triggered – When the [DB] input signal is ON, the inverter immediately applies DC injection braking, whether the inverter is in Run Mode or Stop Mode. You control DC braking time by the duration of the [DB] pulse.
 - b. Edge triggered – When the [DB] input transitions OFF-to-ON and the inverter is in Run Mode, it will apply DC braking only until the motor stops... then DC braking is OFF. During Stop Mode, the inverter ignores OFF-to-ON transitions. Therefore, do not use edge triggered operation when you need DC braking before acceleration.



CAUTION: Be careful to avoid specifying a braking time that is long enough to cause motor overheating. If you use DC braking, we recommend using a motor with a built-in thermistor and wiring it to the inverter’s thermistor input (see [“Thermistor Thermal Protection”](#) on page 4-25). Also refer to the motor manufacturer’s specifications for duty-cycle recommendations during DC braking.

Func. Code	Name/Description	Keypad		Range and Settings	Defaults			Run Mode Edit Lo Hi
		SRW	OPE		FEF2 FE2 (EU)	FUF2 FU2 (USA)	FF2 F2 (Jpn)	
A051	DC braking enable	OFF	00	Disable	00	00	00	✓
		ON	01	Enable				✓
		DOH	02	Brake at set frequency only				✓
A052	DC braking frequency setting	0.00 to 60.00 (Hz)			0.50	0.50	0.50	✓
	Frequency at which DC braking activates during decel.							✓
A053	DC braking wait time	0.0 to 5.0 (seconds)			0.0	0.0	0.0	✓
	The delay after reaching the DC braking frequency, or [DB] signal, before DC braking begins							✓
A054	DC braking force during deceleration	0. to 80. (%)			0.	0.	0.	✓
	Variable DC braking force							✓
A055	DC braking time for deceleration	0.0 to 60.0 (seconds)			0.0	0.0	0.0	✓
	Sets the duration for DC braking during decel							✓
A056	DC braking / edge or level detection for [DB] input	EDGE	00	Edge detection	01	01	01	✓
		LEVEL	01	Level detection				
A057	DC braking force for starting	0. to 80. (%)			0.	0.	0.	✓
	Variable DC braking force							
A058	DC braking time for starting	0.0 to 60.0 (seconds)			0.0	0.0	0.0	✓
	Sets the duration for DC braking before accel.							
A059	DC braking carrier frequency setting	0.5 to 15 (kHz) up to SJ700-1500; 0.5 to 3.0kHz for models SJ700-1850 to SJ700-4000			3.0	3.0	3.0	✗ ✗

Derating of DC Braking – The inverter uses an internal carrier frequency (set by A059) to generate a DC braking voltage (do not confuse with main inverter output carrier frequency set by B083). The maximum DC braking force available to the inverter is more limited with higher DC braking carrier frequency settings for A059 according to the graphs below.

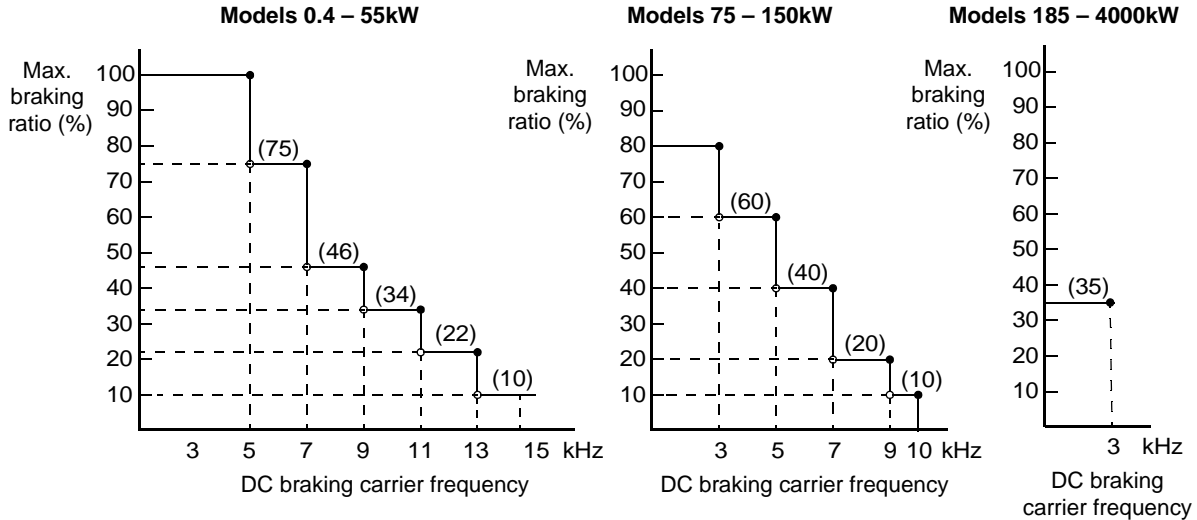

Frequency-related Functions

Frequency Limits – Upper and lower limits can be imposed on the inverter output frequency. These limits will apply regardless of the source of the speed reference. You can configure the lower frequency limit to be greater than zero as shown in the graph to the right. The upper limit must not exceed the rating of the motor or capability of the machinery.

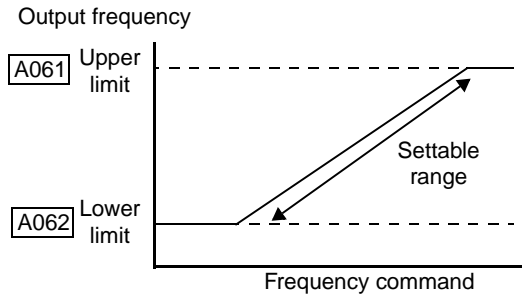

Func. Code	Name/ SRW Display	Keypad		Range and settings	Defaults			Run Mode Edit Lo Hi
		SRW	OPE		FEF2 FE2 (EU)	FUF2 FU2 (USA)	FF2 F2 (Jpn)	
A061	Frequency upper limit setting	0000.00	0.00	Setting is disabled	0.00	0.00	0.00	X ✓
	Sets a limit on output frequency less than the maximum frequency (A004)	0000.50	>0.50	Setting is enabled, 0.50 to 400.0 (Hz)				X ✓
A261	Frequency upper limit setting, 2nd motor	0000.00	0.00	Setting is disabled	0.00	0.00	0.00	X ✓
	Sets a limit on output frequency less than the maximum frequency (A004)	0000.50	>0.50	Setting is enabled, 0.50 to 400.0 (Hz)				X ✓
A062	Frequency lower limit setting	0000.00	0.00	Setting is disabled	0.00	0.00	0.00	X ✓
	Sets a limit on output frequency greater than zero	0000.50	>0.50	Setting is enabled, 0.50 to 400.0 (Hz)				X ✓
A262	Frequency lower limit setting, 2nd motor	0000.00	0.00	Setting is disabled	0.00	0.00	0.00	X ✓
	Sets a limit on output frequency greater than zero	0000.50	>0.50	Setting is enabled, 0.50 to 400.0 (Hz)				X ✓

Configuring Drive Parameters

Jump Frequencies – Some motors or machines exhibit resonances at particular speed(s), which can be destructive for prolonged running at those speeds. The inverter has up to three *jump frequencies* as shown in the graph. The hysteresis around the jump frequencies causes the inverter output to skip around the sensitive frequency values.

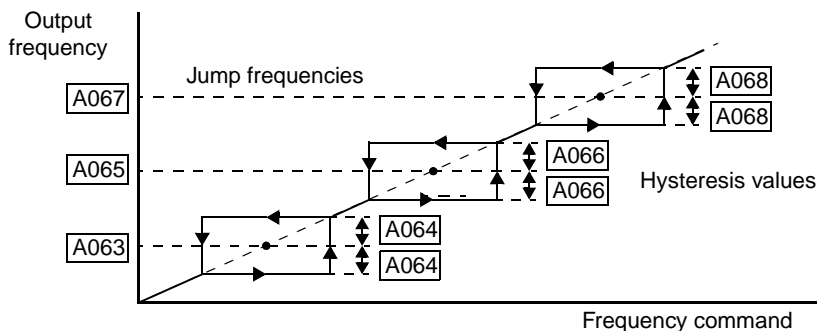

Func. Code	Name/Description	Range and Settings	Defaults			Run Mode Edit Lo Hi
			FEF2 FE2 (EU)	FUF2 FU2 (USA)	FF2 F2 (Jpn)	
A063 A065 A067	Jump (center) frequency setting Up to three output frequencies can be defined for the output to jump past to avoid motor resonances (center frequency)	0.00 to 400.0 (Hz); model -4000HFx2 is 0.00 to 120.0 (Hz)	0.00	0.00	0.00	✗ ✓ ✗ ✓
A064 A066 A068	Jump (hysteresis) frequency width setting Defines the distance from the center frequency at which the jump occurs	Range is 0.0 to 10.0 Hz	0.50	0.50	0.50	✗ ✓ ✗ ✓

Acceleration Pause Function

The acceleration pause function can be used to minimize the occurrence of over-current trips when accelerating high inertia loads. It introduces a dwell or pause in the acceleration ramp. You can control the frequency at which this dwell occurs (A069), and the duration of the pause time (A070). This function can also be used as an anti-windmilling tool, when the load might have a tendency to drive the motor in a reverse direction while the inverter is in a Stop mode. Initiating a normal acceleration in such a situation may result in over-current trips. This function can be used to keep the inverter output frequency and voltage at low levels long enough to bring the load to a stop, and commence turning in the desired direction before the acceleration ramp resumes. See also [“DC Braking Settings” on page 3-18.](#)

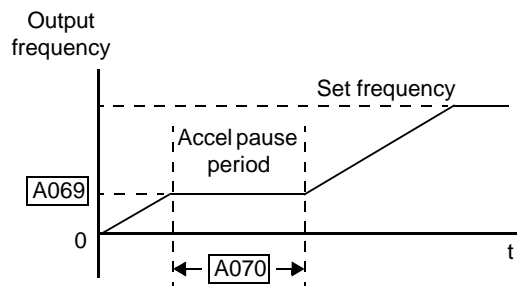

Func. Code	Name/Description	Range and Settings	Defaults			Run Mode Edit Lo Hi
			FEF2 FE2 (EU)	FUF2 FU2 (USA)	FF2 F2 (Jpn)	
A069	Acceleration pause frequency setting	0.00 to 400.0 (Hz); model -4000HFx2 is 0.00 to 120.0 (Hz)	0.00	0.00	0.00	✗ ✓
A070	Acceleration pause time setting	0.0 to 60.0 (seconds)	0.0	0.0	0.0	✗ ✓

Configuring Drive Parameters

PID Control

When enabled, the built-in PID loop calculates an ideal inverter output value to cause a loop feedback process variable (PV) to move closer in value to the setpoint (SP). The current frequency command serves as the SP. The PID loop algorithm will read the analog input for the process variable (you specify either current or voltage input) and calculate the output.

- A scale factor in A075 lets you multiply the PV by a factor, converting it into engineering units for the process.
- Proportional, integral, and derivative gains are all adjustable.
- Optional – You can assign an intelligent input terminal the option code 23, PID Disable. When active, this input disables PID operation. See [“Intelligent Input Terminal Overview” on page 3-51](#).
- See [“PID Loop Operation” on page 4-75](#) for more information.

Func. Code	Name/Description	Keypad		Range and Settings	Defaults			Run Mode Edit Lo Hi
		SRW	OPE		FEF2 FE2 (EU)	FUF2 FU2 (USA)	FF2 F2 (Jpn)	
A071	PID Enable	OFF	00	PID operation OFF	00	00	00	X ✓
		ON	01	PID operation ON				X ✓
		R-ON	02	PID operation ON with inverted output				X ✓
A072	PID proportional gain			0.2 to 5.0	1.0	1.0	1.0	✓ ✓
A073	PID integral time constant			0.0 to 999.9, 1000. to 3600. (seconds)	1.0	1.0	1.0	✓ ✓
A074	PID derivative time constant			0.0 to 99.99, 100.0 (seconds)	0.0	0.0	0.0	✓ ✓
A075	PV scale conversion			0.01 to 99.99, 100.0 (seconds)	1.00	1.00	1.00	X ✓
	Process Variable (PV) scale factor (multiplier)							X ✓
A076	PV source setting	OI	00	[OI] terminal (current input)	00	00	00	X ✓
	Selects source of Process Variable (PV)	O	01	[O] terminal (voltage input)				X ✓
		COM	02	Communication input				X ✓
		PLS	03	Pulse train frequency input				X ✓
		MATH	10	CALCULATE function output				X ✓
A077	Reverse PID Action	OFF	00	PID input = SP – PV (normal)	00	00	00	X ✓
	Changes response to error	ON	01	PID input = -(SP – PV) (reverse)				X ✓
A078	PID output limit			Range is 0.0 to 100.0	0.00	0.00	0.00	X ✓
A079	PID feed forward select	no	00	Disable	00	00	00	X ✓
		O	01	[O] terminal (voltage input)				X ✓
		OI	02	[OI] terminal (current input)				X ✓
		O2	03	[O2] terminal (voltage input)				X ✓



NOTE: The setting A073 for the integrator is the integrator's time constant T_i , not the gain. The integrator gain $K_i = 1/T_i$. When you set A073 = 0, the integrator is disabled.

Automatic Voltage Regulation (AVR) Function

The Automatic Voltage Regulation (AVR) feature keeps the inverter output voltage at a relatively constant amplitude during power input fluctuations. This can be useful if the installation is subject to input voltage disturbances. However, the inverter cannot boost its motor output to a voltage higher than the power input voltage. If you enable this feature, be sure to select the proper voltage class setting for your motor.

Func. Code	Name/Description	Keypad		Range and Settings	Defaults			Run Mode Edit Lo Hi
		SRW	OPE		FEF2 FE2 (EU)	FUF2 FU2 (USA)	FF2 F2 (Jpn)	
A081	AVR function select	ON	00	AVR enabled	00	00	02	x x
	Automatic (output) voltage regulation	OFF	01	AVR disabled				
		DOFF	02	AVR enabled except during deceleration				
A082	AVR voltage select			200V class inverter settings: 200/215/220/230/240 (V) 400V class inverter settings: 380/400/415/440/460/480 (V)	230/400	230/460	200/400	x x

Energy Savings Mode / Optimal Accel/Decel

Energy Savings Mode – This function allows the inverter to deliver the minimum power necessary to maintain speed at any given frequency. This works best when driving variable torque characteristic loads such as fans and pumps. Parameter A085=01 enables this function and A086 controls the degree of its effect. A setting of 0.0 yields slow response but high accuracy, while a setting of 100 will yield a fast response with lower accuracy.

Func. Code	Name/Description	Keypad		Range and Settings	Defaults			Run Mode Edit Lo Hi
		SRW	OPE		FEF2 FE2 (EU)	FUF2 FU2 (USA)	FF2 F2 (Jpn)	
A085	Operation mode selection	NOR	00	Normal operation	00	00	00	x x
		ECCO	01	Energy-saver operation				x x
		FUZZY	02	Optimal accel/decel operation				x x
A086	Energy saving mode tuning			0.0 to 100 (seconds)	50.0	50.0	50.0	✓ ✓

Optimal Accel/Decel Operation – This feature uses “fuzzy” logic to optimize acceleration and deceleration curves in real time. It is enabled by A085=02. Optimal accel/decel operation automatically adjusts the acceleration and deceleration times in response to changes in load or inertia to take advantage of the maximum output current capability of the inverter. In general, optimal accel/decel will allow for the shortest accel and decel times based on the actual load conditions. The function continuously monitors output current and DC bus voltage to avoid reaching their respective trip levels.



NOTE: In this mode, the settings of acceleration and deceleration times (F002 and F003) are disregarded.

The acceleration time is controlled to maintain output current below the level set by the Overload Restriction Function if enabled (Parameters B021/B024, B022/B025, and B023/B026). If Overload Restriction is not enabled, then the current limit used is 150% of the inverter’s rated output current.

The deceleration time is controlled so that the output current is maintained below 150% of the inverter’s rated current, and the DC bus voltage is maintained below the OV Trip level (358V or 770V).



NOTE: DO NOT use Optimal Accel/Decel (A085 = 02) when an application...

- has a requirement for constant acceleration or deceleration
- has a load inertia more than (approx.) 20 times the motor inertia
- uses internal or external regenerative braking
- uses any of the vector control modes (A044 = 03, 04, or 05). This function is ONLY compatible with V/F control.



NOTE: If the load exceeds the rating of the inverter, the acceleration time may be increased.



NOTE: If using a motor with a capacity that is one size smaller than the inverter rating, enable the Overload Restriction function (B021/B024) and set the Overload Restriction Level (B022/B025) to 1.5 times the motor nameplate current.



NOTE: Be aware that the acceleration and deceleration times will vary, depending on the actual load conditions during each individual operation of the inverter.

Second Acceleration and Deceleration Functions

The SJ7002 inverter features two-stage acceleration and deceleration ramps. This gives flexibility in the profile shape. You can specify the frequency transition point, the point at which the standard acceleration (F002) or deceleration (F003) changes to the second acceleration (A092) or deceleration (A093). These profile options are also available for the second motor settings and third motor settings. All acceleration and deceleration times are time to ramp from zero speed to full speed or full speed to zero speed. Select a transition method via A094 as depicted below. Be careful not to confuse the *second acceleration/deceleration settings* with settings for the *second motor*!

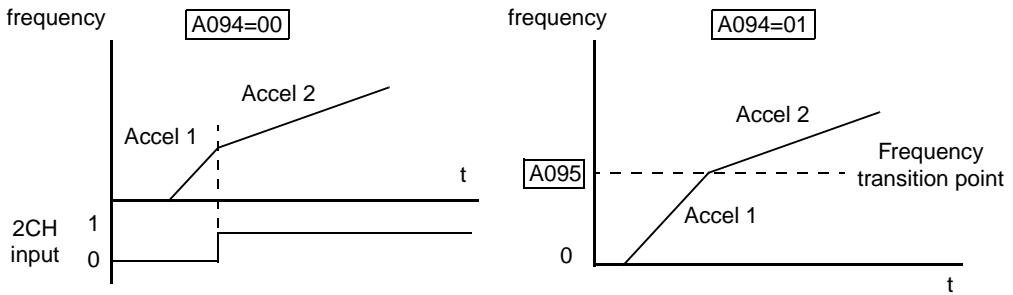

Func. Code	Name/Description	Keypad		Range and Settings	Defaults			Run Mode Edit Lo Hi
		SRW	OPE		FEF2 (EU)	FUF2 (USA)	FF2 (Jpn)	
A092	Acceleration (2) time setting			0.01 to 99.99, 100.0 to 999.9, 1000. to 3600. (seconds)	15.0	15.0	15.0	✓✓
	Duration of 2nd segment of acceleration							
A292	Acceleration (2) time setting, 2nd motor			0.01 to 99.99, 100.0 to 999.9, 1000. to 3600. (seconds)	15.0	15.0	15.0	✓✓
	Duration of 2nd segment of acceleration, 2nd motor							
A392	Acceleration (2) time setting, 3rd motor			0.01 to 99.99, 100.0 to 999.9, 1000. to 3600. (seconds)	15.0	15.0	15.0	✓✓
	Duration of 2nd segment of acceleration, 3rd motor							

Func. Code	Name/Description	Keypad		Range and Settings	Defaults			Run Mode Edit Lo Hi
		SRW	OPE		FEF2 FE2 (EU)	FUF2 FU2 (USA)	FF2 F2 (Jpn)	
A093	Deceleration (2) time setting	—	—	0.01 to 99.99, 100.0 to 999.9, 1000. to 3600. (seconds)	15.0	15.0	15.0	✓ ✓
	Duration of 2nd segment of deceleration							
A293	Deceleration (2) time setting, 2nd motor	—	—	0.01 to 99.99, 100.0 to 999.9, 1000. to 3600. (seconds)	15.0	15.0	15.0	✓ ✓
	Duration of 2nd segment of deceleration, 2nd motor							
A393	Deceleration (2) time setting, 3rd motor	—	—	0.01 to 99.99, 100.0 to 999.9, 1000. to 3600. (seconds)	15.0	15.0	15.0	✓ ✓
	Duration of 2nd segment of deceleration, 3rd motor							✓ ✓
A094	Select method to switch to Acc2/Dec2 profile	TM	00	[2CH] input from terminal	00	00	00	× ×
		FREE	01	transition frequency				
		F-R	02	when motor direction reverses				
A294	Select method to switch to Acc2/Dec2 profile, 2nd motor	TM	00	[2CH] input from terminal	00	00	00	× ×
		FREE	01	transition frequency				
		F-R	02	when motor direction reverses				
A095	Acc1 to Acc2 frequency transition point			0.00 to 400.0 (Hz); model -4000HFx2 is 0.00 to 120.0 (Hz)	0.0	0.0	0.0	× ×
	Output frequency at which Accel1 switches to Accel2							
A295	Acc1 to Acc2 frequency transition point, 2nd motor			0.00 to 400.0 (Hz); model -4000HFx2 is 0.00 to 120.0 (Hz)	0.0	0.0	0.0	× ×
	Output frequency at which Accel1 switches to Accel2							
A096	Dec1 to Dec2 frequency transition point			0.00 to 400.0 (Hz); model -4000HFx2 is 0.00 to 120.0 (Hz)	0.0	0.0	0.0	× ×
	Output frequency at which Decel1 switches to Decel2							
A296	Dec1 to Dec2 frequency transition point, 2nd motor			0.00 to 400.0 (Hz); model -4000HFx2 is 0.00 to 120.0 (Hz)	0.0	0.0	0.0	× ×
	Output frequency at which Decel1 switches to Decel2							



NOTE: For A095 and A096 (and for 2nd motor settings), if you set a very rapid Acc1 or Dec1 time (less than 1.0 second), the inverter may not be able to change rates to Acc2 or Dec2 before reaching the target frequency. In that case, the inverter decreases the rate of Acc1 or Dec1 in order to achieve the second ramp to the target frequency.

Accel/Decel Characteristics

Standard (default) acceleration and deceleration is linear with time. The inverter CPU can also calculate other curves shown in the graphs below. The sigmoid, U-shape, and reverse U-shape curves are useful for favoring the load characteristics in particular applications. Curve settings for acceleration and deceleration are independently selected via parameters A097 and A098, respectively. You can use the same or different curve types for acceleration and deceleration.

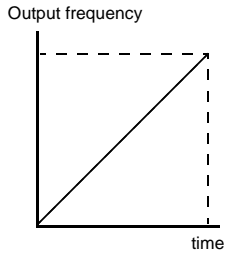
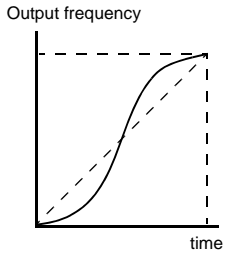
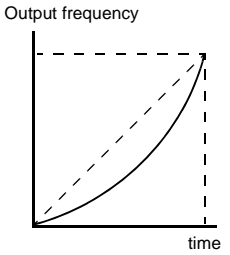
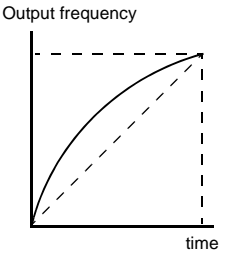
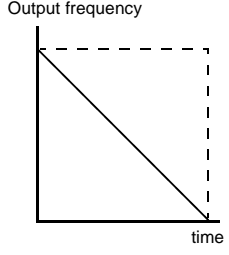
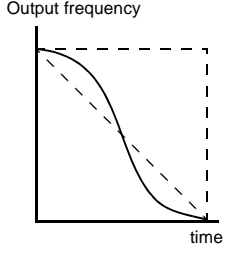
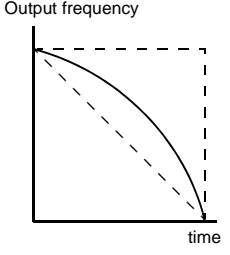
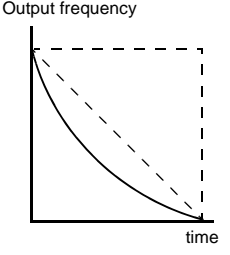
Set value	00	01	02	03
Curve	Linear	Sigmoid	U-shape	Reverse U-shape
Accel A97				
Decel A98				
Typical applications	Linear acceleration and deceleration for general-purpose use	Avoid jerk on start/stop for elevators; use for delicate loads on conveyors	Tension control for winding applications, web presses, roller/accumulators	

Configuring Drive Parameters

Func. Code	Name/Description	Keypad		Range and Settings	Defaults			Run Mode Edit Lo Hi
		SRW	OPE		xFE2 (EU)	xFU2 (USA)	xFF2 (Jpn)	
A097	Acceleration curve selection	Linear	00	Linear	00	00	00	X X
	Set the characteristic curve of Accel1 and Accel2	S-curve	01	S-curve				
		U-curve	02	U-shape				
		RU-curve	03	Reverse U-shape				
		EL-curve	04	EL-S curve				
A098	Deceleration curve selection	Linear	00	Linear	00	00	00	X X
	Set the characteristic curve of Decel1 and Decel2	S-curve	01	S-curve				
		U-curve	02	U-shape				
		RU-curve	03	Reverse U-shape				
		EL-curve	04	EL-S curve				

The acceleration and deceleration curves can deviate from a straight line to a varying degree. Parameters A131 and A132 control the amount of deviation for the acceleration and deceleration curves respectively. The following graphs show intermediate output frequency points as a percentage of the target frequency, for 25%, 50%, and 75% acceleration time intervals.

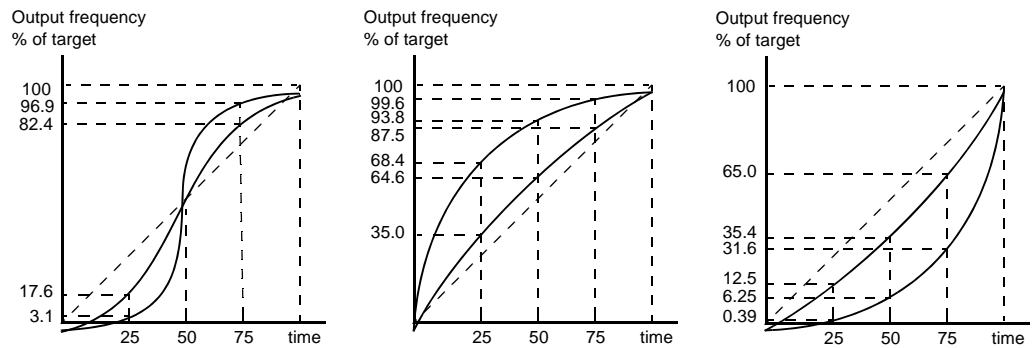

Func. Code	Name/Description	Keypad		Range and Settings	Defaults			Run Mode Edit Lo Hi
		SRW	OPE		FEF2 FE2 (EU)	FUF2 FU2 (USA)	FF2 F2 (Jpn)	
A131	Acceleration curve constants setting	01 ...	0 / ...	Smallest deviation	02	02	02	x ✓
	Sets the curve deviation from straight-line acceleration in 10 levels	10	10	Largest deviation				x ✓
A132	Deceleration curve constants setting	01 ...	0 / ...	Smallest deviation	02	02	02	x ✓
	Sets the curve deviation from straight-line deceleration in 10 levels	10	10	Largest deviation				x ✓

Additional Analog Input Settings

The parameters in the following table adjust the input characteristics of the analog inputs. When using the inputs to command the inverter output frequency, these parameters adjust the starting and ending ranges for the voltage or current, as well as the output frequency range. Related characteristic diagrams are located in [“Analog Input and Miscellaneous Settings” on page 3-11.](#)

Func. Code	Name/Description	Keypad		Range and Settings	Defaults			Run Mode Edit Lo Hi
		SRW	OPE		FEF2 FE2 (EU)	FUF2 FU2 (USA)	FF2 F2 (Jpn)	
A101	[OI]-[L] input active range start frequency	—	—	0.00 to 400.0 (Hz); model -4000HFx2 is 0.00 to 120.0 (Hz)	00.0	00.0	00.0	x ✓
	Output frequency corresponding to the current input range starting point							
A102	[OI]-[L] input active range end frequency	—	—	0.00 to 400.0 (Hz); model -4000HFx2 is 0.00 to 120.0 (Hz)	00.0	00.0	00.0	x ✓
	Output frequency corresponding to the current input range ending point							
A103	[OI]-[L] input active range start current	—	—	0 to 100%	20.	20.	20.	x ✓
	Starting point for the current input range							
A104	[OI]-[L] input active range end current	—	—	0 to 100%	100.	100.	100.	x ✓
	Ending point for the current input range							

Configuring Drive Parameters

Func. Code	Name/Description	Keypad		Range and Settings	Defaults			Run Mode Edit Lo Hi
		SRW	OPE		FEF2 FE2 (EU)	FUF2 FU2 (USA)	FF2 F2 (Jpn)	
A105	[OI]-[L] input start frequency enable	OI-EXS	00	Use A101 start value	01	01	01	X ✓
		0Hz	01	Use 0Hz				
A111	[O2]-[L] input active range start frequency	—	—	-400. to 400. (Hz); model -4000HFx2 is 0.00 to 120.0 (Hz)	0.00	0.00	0.00	X ✓
	Output frequency corresponding to the bipolar voltage input range starting point							
A112	[O2]-[L] input active range end frequency	—	—	-400. to 400. (Hz); model -4000HFx2 is 0.00 to 120.0 (Hz)	0.00	0.00	0.00	X ✓
	Output frequency corresponding to the bipolar voltage input range ending point							
A113	[O2]-[L] input active range start voltage	—	—	-100 to 100 (%)	-100.	-100.	-100.	X ✓
	Starting point for the bipolar voltage input range							
A114	[O2]-[L] input active range end voltage	—	—	-100 to 100 (%)	100.	100.	100.	X ✓
	Ending point for the bipolar voltage input range							

Target Frequency Analog Input Calculate Function Operation – The inverter can mathematically combine two input sources into one value. The Calculate function can either add, subtract, or multiply the two selected sources. This provides the flexibility needed by various applications. You can use the result for the output frequency setting (use A001=10) or for the PID Process Variable (PV) input (use A075=03).

Func. Code	Name/Description	Keypad		Range and Settings	Defaults			Run Mode Edit Lo Hi
		SRW	OPE		FEF2 FE2 (EU)	FUF2 FU2 (USA)	FF2 F2 (Jpn)	
A141	A input select for Calculate Function	REM	00	Digital operator (A020/A220/A320)	02	02	02	X ✓
		VR	01	Keypad potentiometer				
		0	02	[O] input				
		OI	03	[OI] input				
		COM	04	Comm. port				
		OP1	05	Expansion card 1				
		OP2	06	Expansion card 2				
		PLS	07	Pulse train frequency train input				
A142	B input select for Calculate Function	REM	00	Digital operator (A020/A220/A320)	03	03	03	X ✓
		VR	01	Keypad potentiometer				
		0	02	[O] input				
		OI	03	[OI] input				
		COM	04	Comm. port				
		OP1	05	Expansion card 1				
		OP2	06	Expansion card 2				
		PLS	07	Pulse train frequency train input				

Func. Code	Name/Description	Keypad		Range and Settings	Defaults			Run Mode Edit Lo Hi
		SRW	OPE		FEF2 FE2 (EU)	FUF2 FU2 (USA)	FF2 F2 (Jpn)	
A143	Calculation symbol	ADD	00	ADD (A input + B input)	00	00	00	X ✓
	Calculates a value based on the A input (A141 selects) and the B input (A142 selects)	SUB	01	SUB (A input - B input)				
		MUL	02	MUL (A input x B input)				
A145	ADD frequency	—	—	0.00 to 99.99, 100.0 to 400.0 (Hz)	0.00	0.00	0.00	X ✓
A146	ADD direction select	FW	00	Plus (adds A145 value to output frequency)	00	00	00	X ✓
		RV	01	Minus (subtracts A145 value from output frequency)				

Elevator Accel/Decel Curves

Parameters A150 to A153 affect the slope of the acceleration and deceleration for the elevator-related S curves.

Func. Code	Name/Description	Range and Settings	Defaults			Run Mode Edit Lo Hi
			FEF2 FE2 (EU)	FUF2 FU2 (USA)	FF2 F2 (Jpn)	
A150	EL-S curve accel. ratio 1	Range is 0. to 50. (%)	25.	25.	25.	X X
A151	EL-S curve accel. ratio 2	Range is 0. to 50.	25.	25.	25.	X X
A152	EL-S curve decel. ratio 1	Range is 0. to 50.	25.	25.	25.	X X
A153	EL-S curve decel. ratio 3	Range is 0. to 50.	25.	25.	25.	X X

“B” Group: Fine-Tuning Functions

The “B” Group of functions and parameters adjust some of the more subtle but useful aspects of motor control and system configuration.

Automatic Restart Mode and Phase Loss

The restart mode determines how the inverter will resume operation after a fault causes a trip event. The four options provide advantages for various situations. Frequency matching allows the inverter to read the motor speed by virtue of its residual magnetic flux and restart the output at the corresponding frequency. The inverter can attempt a restart a certain number of times depending on the particular trip event:

- Over-current trip, restart up to 3 times
- Over-voltage trip, restart up to 3 times
- Under-voltage trip, restart up to 16 times

When the inverter reaches the maximum number of restarts (3 or 16), you must power-cycle the inverter to reset its operation.

Other parameters specify the allowable under-voltage level and the delay time before restarting. The proper settings depend on the typical fault conditions for your application, the necessity of restarting the process in unattended situations, and whether restarting is always safe.

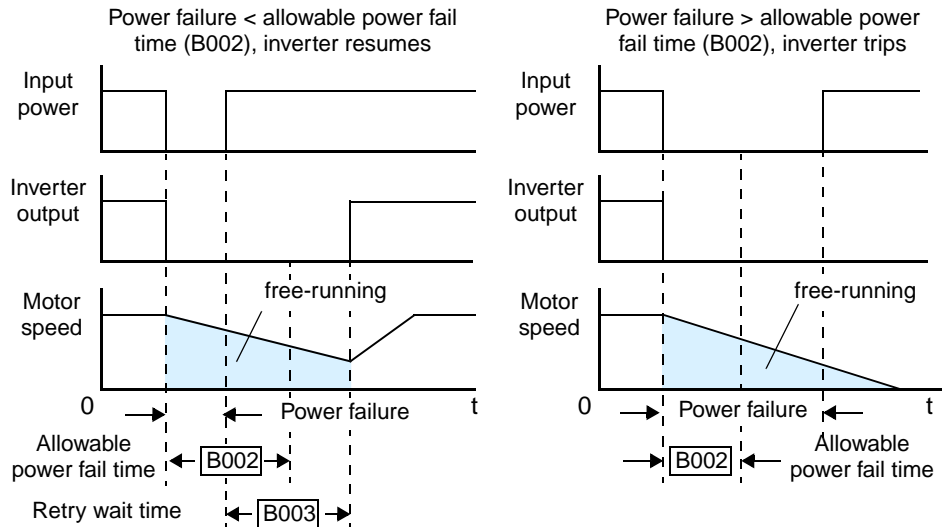

Configuring Drive Parameters

Func. Code	Name/Description	SRW	OPE	Range or Settings	Defaults			Run Mode Edit Lo Hi
					FEF2 FE2 (EU)	FUF2 FU2 (USA)	FF2 F2 (Jpn)	
B001	Selection of automatic restart mode	ALM	00	Alarm output after trip, automatic restart disabled	00	00	00	x ✓
		ZST	01	Restart at 0Hz				
		RST	02	Resume operation after frequency matching				
		FTP	03	Resume previous freq. after freq. matching, then decelerate to stop and display trip info				
		FIX	04	Restart with active matching frequency				

Func. Code	Name/ Description	SRW	OPE	Range or Settings	Defaults			Run Mode Edit Lo Hi
					FEF2 FE2 (EU)	FUF2 FU2 (USA)	FF2 F2 (Jpn)	
B002	Allowable under-voltage power failure time			0.3 to 25.0 (seconds)	1.0	1.0	1.0	✗ ✓
	The amount of time a power input under-voltage can occur without tripping the power failure alarm. If under-voltage exists longer than this time, the inverter trips, even if the restart mode is selected. If it exists less than this time retry will be attempted.							
B003	Retry wait time before motor restart			0.3 to 100 (seconds)	1.0	1.0	1.0	✗ ✓
	Time delay after a trip condition goes away before the inverter restarts the motor							
B004	Instantaneous power failure / under-voltage trip alarm enable	OFF	00	Disable	00	00	00	✗ ✓
		ON	01	Enable				
		DOFF	02	Disable during stop and ramp to stop				
B005	Number of restarts on power failure / under-voltage trip events	16	00	Restart 16 times	00	00	00	✗ ✓
		FREE	01	Always restart				
B006	Phase loss detection enable	OFF	00	Disable – no trip on phase loss	00	00	00	✗ ✓
		ON	01	Enable – trip on phase loss				
B007	Restart frequency threshold			0.00 to 400.0 (Hz); model -4000HFx2 is 0.00 to 120.0 (Hz)	0.00	0.00	0.00	✗ ✓
	When the frequency of the motor is less than this value, the inverter will restart at 0 Hz							
B008	Retry after trip select	ALM	00	Always retry after trip	00	00	00	✗ ✓
		ZST	01	Start with 0 Hz				
		RST	02	Start with frequency matching				
		FTP	03	Retry after deceleration and stop with matching frequency				
		FIX	04	Start with active matching frequency				
B009	Retry after undervoltage select	16	00	16 times	00	00	00	✗ ✓
		FREE	01	Unlimited				
B010	Retry count select after over-voltage or overcurrent			1 to 3 (times)	3	3	3	✗ ✓
B011	Retry wait time after trip			0.3 to 100.0 (seconds)	1.0	1.0	1.0	✗ ✓



CAUTION: When a loss of phase occurs, increased ripple current will markedly reduce main capacitor life over time. Diode bridge failure can also result. If phase loss occurs under load, the inverter could be damaged. Please pay particular attention to the setting of function B006.

Electronic Thermal Overload Alarm Setting

The thermal overload detection protects the inverter and motor from overheating due to an excessive load. It uses a current/inverse time curve to determine the trip point. The thermal overload alarm [THM] is the resulting intelligent output.

First, use B013 to select the torque characteristic that matches your load. This allows the inverter to utilize the best thermal overload characteristic for your application.

The torque developed in a motor is directly proportional to the current in the windings, which is also proportional to the heat generated (and temperature, over time). Therefore, you must set the thermal overload threshold in terms of current (amperes) with parameter B012. The range is 50% to 120% of the rated current for each inverter model. If the current exceeds the level you specify, the inverter will trip and log an event (error E05) in the history table. The inverter turns the motor output OFF when tripped. Separate settings are available for the second and third motors (if applicable), as shown in the table below.

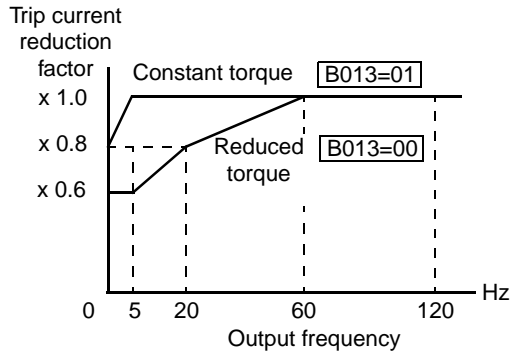

Function Code	Function/Description	Data or Range
B012/B212 / B312	Electronic thermal setting (calculated within the inverter from current output)	Range is 0.2 x rated current to 1.0 x rated current

Example 1, setting for SJ700-110LFE2 (0.4 to 55kW) - The rated motor current is 64A. The setting range is (0.2 * 64) to rated current, or 12.8A to 64.0A. For a setting of B012 = 64A (current at 100% rated current), the curve is shown below.

Example 2, setting for SJ700-750LFE2 (75 to 150 kW) - The rated motor current is 149A. The setting range is (0.2 * 149) to rated current, or 29.8A to 149A. For a setting of B012 = 149A (current at 100% rated current), the curve is shown below.

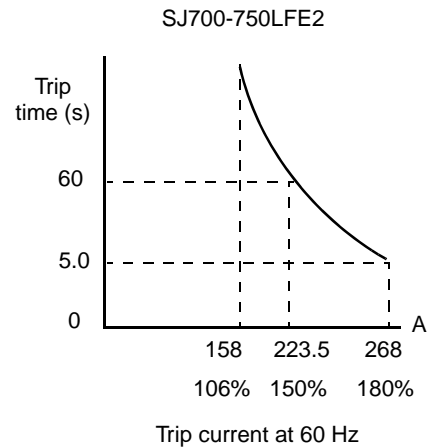
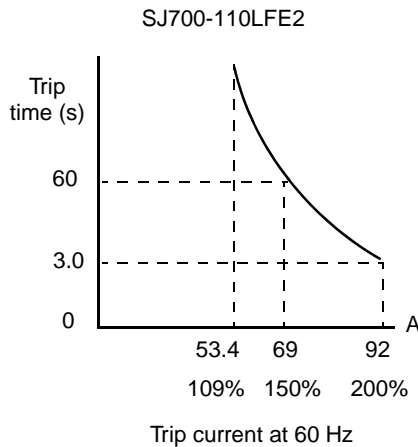

Configuring Drive Parameters

Example 3, setting for SJ700-3150LFE2 (185 to 400kW) - The rated motor current is 600A. The setting range is $(0.2 * 64)$ to rated current, or 120A to 600A. For a setting of B012 = 600A (current at 100% rated current), the curve is shown to the right.

The electronic thermal characteristic adjusts the way the inverter calculates thermal heating, based on the type of load connected to the motor, as set by parameter B013.



CAUTION: When the motor runs at lower speeds, the cooling effect of the motor's internal fan decreases.

The table below shows the torque profile settings. Use the one that matches your load.

Function Code	Data	Function/Description
B013 / B213 / B313	00	Reduced torque
	01	Constant torque
	02	Free-setting

Reduced Torque Characteristic – The example below shows the effect of the reduced torque characteristic curve (for example motor and current rating). At 20Hz, the output current is reduced by a factor of 0.8 for given trip times.

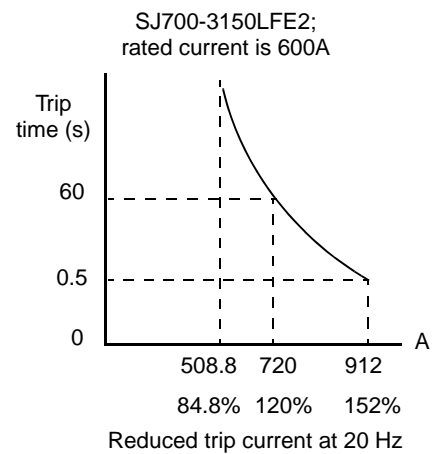
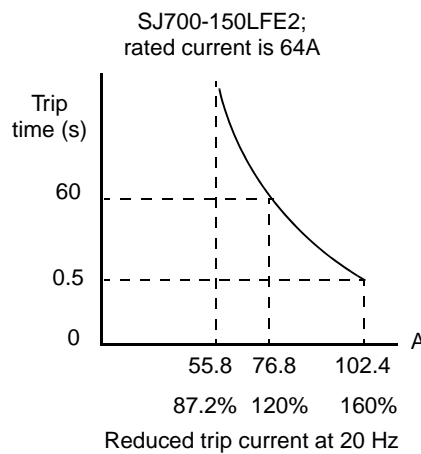
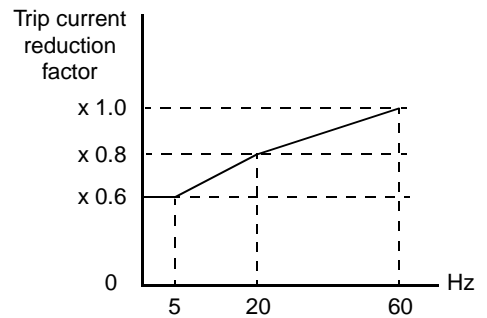
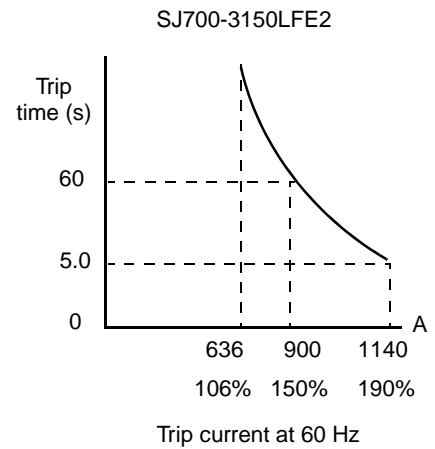

Constant Torque Characteristic – Selecting the constant torque characteristic for the example motor gives the curves below. At 2.5 Hz, the output current is reduced by a factor of 0.9 for given trip times.

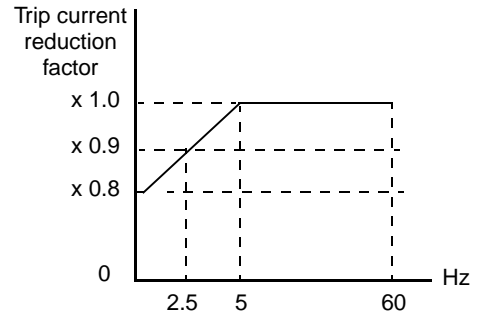

SJ700-150LFE2;
rated current is 64A

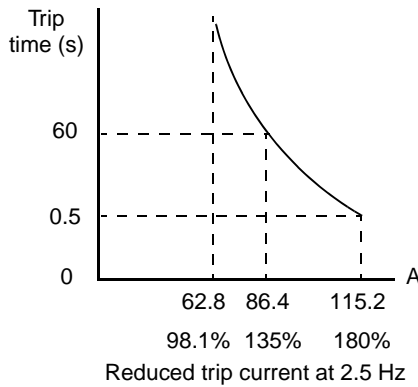

SJ700-3150LFE2;
rated current is 600A

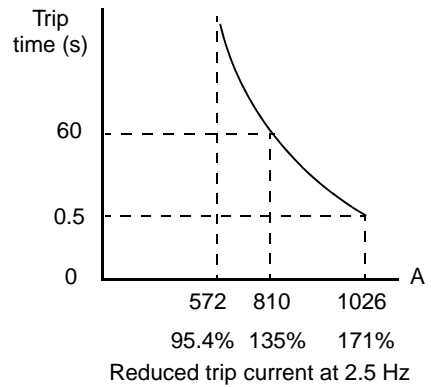

Free Thermal Characteristic - It is possible to set the electronic thermal characteristic using a free-form curve defined by three data points, according to the table below.

Function Code	Name	Description	Range
B015 / B017 / B019	Free-setting electronic thermal frequency 1, 2, 3	Data point coordinates for Hz axis (horizontal) in the free-form curve	0 to 400 (Hz); model -4000HFx2 is 0.00 to 120.0 (Hz)
B016 / B018 / B020	Free setting electronic thermal current 1, 2, 3	Data point coordinates for Ampere axis (vertical) in the free-form curve	0.0 = (disable) 0.1 to 1000.

The left graph below shows the region for possible free-setting curves. The right graph below shows an example curve defined by three data points specified by B015 – B020.

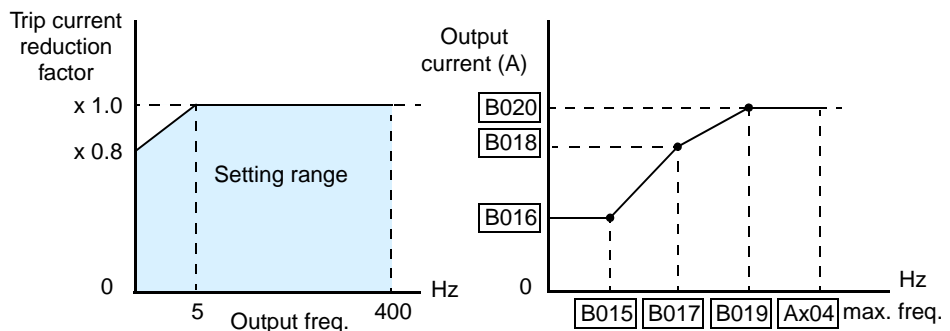

Suppose the electronic thermal setting (B012) is set to 44 Amperes. The left graph below shows the effect of the free setting torque characteristic curve. For example, at (B017) Hz, the output current level to cause overheating in a fixed time period is reduced by a factor of (B018). The right graph below shows the reduced trip current levels in those conditions for given trip times.

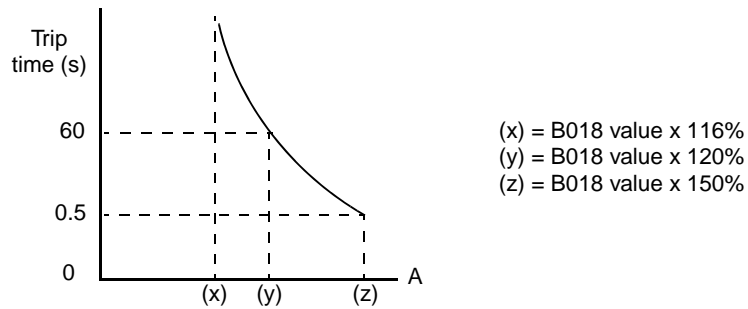

Reduced trip current at (B017) Hz

Any intelligent output terminal may be programmed to indicate a thermal warning [THM]. Parameter C061 determines the warning threshold. Please see [“Thermal Warning Signal” on page 4-52](#) for more details.

Func. Code	Name/Description	Keypad		Range and Settings	Defaults			Run Mode Edit Lo Hi
		SRW	OPE		FEF2 FE2 (EU)	FUF2 FU2 (USA)	FF2 F2 (Jpn)	
B012	Level of electronic thermal setting			0.20 x rated current) to (2.00 x rated current) (A)	rated current of inverter			✗ ✓
B212	Level of electronic thermal setting, 2nd motor			0.20 x rated current) to (2.00 x rated current) (A)	rated current of inverter			✗ ✓
B312	Level of electronic thermal setting, 3rd motor			0.20 x rated current) to (2.00 x rated current) (A)	rated current of inverter			✗ ✓
B013	Electronic thermal characteristic	SUB	00	Reduced torque	01	01	00	✗ ✓
		CRT	01	Constant torque				
		FREE	02	V/f free-setting				
B213	Electronic thermal characteristic, 2nd motor	SUB	00	Reduced torque	01	01	00	✗ ✓
		CRT	01	Constant torque				
		FREE	02	V/f free-setting				
B313	Electronic thermal characteristic, 3rd motor	SUB	00	Reduced torque	01	01	00	✗ ✓
		CRT	01	Constant torque				
		FREE	02	V/f free-setting				
B015	Free setting, electronic thermal frequency (1)			0.0 to 400.0 (Hz); model -4000HFx2 is 0.00 to 120.0 (Hz)	0.	0.	0.	✗ ✓
B016	Free setting, electronic thermal current (1)			0.0 to 1000. (A)	0.0	0.0	0.0	✗ ✓
B017	Free setting, electronic thermal frequency (2)			0.0 to 400.0 (Hz); model -4000HFx2 is 0.00 to 120.0 (Hz)	0.	0.	0.	✗ ✓
B018	Free setting, electronic thermal current (2)			0.0 to 1000. (A)	0.0	0.0	0.0	✗ ✓
B019	Free setting, electronic thermal frequency (3)			0.0 to 400.0 (Hz); model -4000HFx2 is 0.00 to 120.0 (Hz)	0.	0.	0.	✗ ✓
B020	Free setting, electronic thermal current (3)			0.0 to 1000. (A)	0.0	0.0	0.0	✗ ✓

Overload Restriction

If the inverter's output current exceeds a preset current level you specify during acceleration or constant speed, the overload restriction feature automatically reduces the output frequency to restrict the overload. This feature does not generate an alarm or trip event. You can instruct the inverter to apply overload restriction only during constant speed, thus allowing higher currents for acceleration. Or, you may use the same threshold for both acceleration and constant speed. In the case of controlled deceleration, the inverter monitors both output current and DC bus voltage. The inverter will increase output frequency to try to avoid a trip due to over-current or over-voltage (due to regeneration).

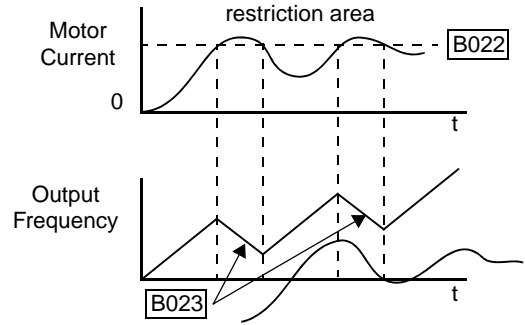

When the inverter detects an overload, it must decelerate the motor to reduce the current until it is less than the threshold. You can choose the rate of deceleration that the inverter uses to lower the output current.

Configuring Drive Parameters

Func. Code	Name/Description	Keypad		Range and Settings	Defaults			Run Mode Edit Lo Hi
		SRW	OPE		FEF2 FE2 (EU)	FUF2 FU2 (USA)	FF2 F2 (Jpn)	
B021	Overload restriction operation mode	OFF	00	Disable	01	01	01	X ✓
	Select the operating mode during overload conditions	ON	01	Enable for acceleration and constant speed				
		CRT	02	Enable for constant speed only				
		N-R	03	Enable for accel, decel, and constant speed				
B022	Overload restriction setting			(0.20 x rated current) to (1.80 x rated current) (A)	rated current times 1.50			X ✓
B023	Deceleration rate at overload restriction			0.10 to 30.00 (seconds)	1.00	1.00	1.00	X ✓
B024	Overload restriction operation mode (2)	OFF	00	Disable	01	01	01	X ✓
	Select the operating mode during overload conditions	ON	01	Enable for acceleration and constant speed				
		CRT	02	Enable for constant speed only				
		N-R	03	Enable for accel, decel, and constant speed				
B025	Overload restriction setting (2)			Models -004xxx to -550xxx: (0.20 x rated current) to (2.0 x rated current) (A); Models -750xxx to -4000xxx: (0.20 x rated current) to (1.80 x rated current) (A)	rated current times 1.50			X ✓
B026	Deceleration rate at overload restriction (2)			0.10 to 30.00 (seconds)	1.00	1.00	1.00	X ✓
B027	Overcurrent suppression enable	OFF	00	Disable	01	01	01	X ✓
		ON	01	Enable				
B028	Current limit for active frequency-matching restart			Models -004xxx to -550xxx: (0.20 x rated current) to (2.0 x rated current) (A); Models -750xxx to -4000xxx: (0.20 x rated current) to (1.80 x rated current) (A)	rated current times 1.0			X ✓
B029	Scan time constant for active freq. matching			0.10 to 30.00 (seconds)	0.50	0.50	0.50	X ✓

Func. Code	Name/ Description	Keypad		Range and Settings	Defaults			Run Mode Edit Lo Hi
		SRW	OPE		FEF2 FE2 (EU)	FUF2 FU2 (USA)	FF2 F2 (Jpn)	
B030	Restart freq. select for active freq. matching	CUTOFF	00	Frequency at last shutoff	00	00	00	x ✓
		MAX	01	Maximum frequency				
		SET	02	Set frequency				



NOTE: Two sets of overload restriction parameters are available. The set that is in use may be selected by means of an intelligent input terminal (see [“Overload Restriction” on page 4-29](#)).

Software Lock Mode

The software lock function keeps personnel from accidentally changing parameters in the inverter memory. Use B031 to select from various protection levels.

The table below lists all combinations of B031 option codes and the ON/OFF state of the [SFT] input. Each Check ✓ or Ex ✗ indicates whether the corresponding parameter(s) can be edited. The Standard Parameters column below lists Low and High level access for some lock modes. These refer to the parameter tables throughout this chapter, each of which includes a column titled *Run Mode Edit* as shown to the right. The two marks (Check ✓ or Ex ✗) under the “Lo Hi” subtitle indicate whether Low-level and/or High-level access applies to each parameter as defined in the table below. In some lock modes, you can edit only F001 and the Multi-speed parameter group that includes A020, A220, A320, A021–A035, and A038 (Jog). However, it does not include A019, Multi-speed operation selection. The editing access to B031 itself is unique, and is specified in the right-most two columns below.

	Run Mode Edit	
	Lo Hi	
	✗ ✓	

B031 Lock Mode	[SFT] Intelligent Input	Standard Parameters		F001 and Multi-speed	B031	
		Stop	Run	Stop or Run	Stop	Run
00	OFF	✓	Low-level	✓	✓	✗
	ON	✗	✗	✗	✓	✗
01	OFF	✓	Low-level	✓	✓	✗
	ON	✗	✗	✓	✓	✗
02	(ignored)	✗	✗	✗	✓	✗
03	(ignored)	✗	✗	✓	✓	✗
10	(ignored)	✓	High-level	✓	✓	✓



NOTE: Since the software lock function B031 is always accessible when the motor is stopped, this feature is not the same as password protection used in other industrial control devices.

Configuring Drive Parameters

Func. Code	Name/Description	Keypad		Range and Settings	Defaults			Run Mode Edit Lo Hi
		SRW	OPE		FEF2 FE2 (EU)	FUF2 FU2 (USA)	FF2 F2 (Jpn)	
B031	Software lock mode selection	MD0	00	Low-level access, [SFT] input blocks all edits	01	01	01	✗ ✓
		MD1	01	Low-level access, [SFT] input blocks edits (except F001 and Multi-speed parameters)				
		MD2	02	No access to edits				
		MD3	03	No access to edits except F001 and Multi-speed parameters				
		MD10	10	High-level access, including B031				



NOTE: To disable parameter editing when using B031 lock modes 00 and 01, assign the [SFT] function to one of the intelligent input terminals. See [“Software Lock” on page 4-23](#).

Miscellaneous Settings

The miscellaneous settings include scaling factors, initialization modes, and others. This section covers some of the most important settings you may need to configure.

Func. Code	Name/Description	Keypad		Range and Settings	Defaults			Run Mode Edit Lo Hi
		SRW	OPE		FEF2 FE2 (EU)	FUF2 FU2 (USA)	FF2 F2 (Jpn)	
B034	Run/power-on warning time	—	—	0 to 9999. (0 to 99990), 1000 to 6553 (10000 to 655300) (hours)	0.	0.	0.	✕ ✓
B035	Rotational direction restriction	FREE	00	Enable for both directions	00	00	00	✕ ✕
		FW	01	Enable for forward only				✕ ✕
		RW	02	Enable for reverse only				✕ ✕
B036	Reduced voltage start selection	—	—	000 (short) to 255 (long)	06	06	06	✕ ✓

Function Display Settings

The inverter has the (optional) capability to suppress the display and editing of certain parameters. Use B037 to select the display options. The purpose of this feature is to hide particular secondary parameters that become unused or not applicable based on more fundamental parameter settings. For example, setting A001 = 01 configures the inverter to get its frequency command from the front keypad potentiometer. In this case, the inverter will not use the analog inputs nor their adjustment parameters for an external frequency command.

Func. Code	Name/Description	Keypad		Range and Settings	Defaults			Run Mode Edit Lo Hi
		SRW	OPE		xFE2 (EU)	xFU2 (USA)	xFF2 (Jpn)	
B037	Function code display restriction	ALL	00	Display all	04	04	04	✕ ✓
		FUNCTION	01	Display only utilized functions (see table on next page)				
		USER	02	Display user-selected functions only (configure with U01 to U12)				
		COMPARE	03	Data comparison display				
		BASIC	04	Basic display				
B038	Initial display selection	STR	00	Last value displayed when STR key was pressed	01	01	01	✕ ✓
		FM	01	D001				
		Iout	02	D002				
		Dir	03	D003				
		F-CNV	04	D007				
		F-SET	05	F001				
B039	Automatic user parameter function enable	OFF	00	Disable	00	00	00	✕ ✓
		ON	01	Enable				

For example, you can set B037=01 to have the inverter suppress the displaying of all analog input parameters when A001=01, as shown in the first row of the following table.

Function Code	Data	Resulting Non-displayed Functions (when B37 = 01)	Notes
A001	01	A005, A006, A011 – A016, A101 – A114, C081 – C083, C121 – C123	[O], [OI], [O2] terminal functions

Function Code	Data	Resulting Non-displayed Functions (when B37 = 01)	Notes
A002	01, 03, 04, 05	B087	Stop key function
A019	00	A028 – A035	Multi-speed function
C001 – C008	02, 03, 04, 05		

Function Code	Data	Resulting Non-displayed Functions (when B37 = 01)	Notes
A044, A244	02	B100 – B113	Control methods
A051	01	A052 – A059	DC braking
A071	01	A072 – A076, C044	PID function
A094	01	A095 – A096	2-stage adjustable frequency
A294	01	A0295 – A296	
B013, B213, B313	02	B015 – B020	Electric thermal characteristic
B021	01, 02	B022, B023	Overload restriction
B024	01, 02	B025, B026	Overload restriction 2
B095	01, 02	B090 – B096	Dynamic braking function
C001 – C008	06	A038, A039	Jogging
	08	F202, F203, A203, A204, A220, A241 – A244, A261, A262, A292 – A296, B212, B213, H202 – H206, H220 – H224, H230 – H234, H250 – H252, H260	2nd motor control
	11	B088	Free-run stop
	17	F302, F303, A303, A304, A320, A342 – A344, A392, A393, B312, B313, H306	3rd motor control
	18	C102	Reset
	27, 28, 29	C101	UP/DWN
A044	00, 01	A041 – A043	Torque boost function
	04	H060	0Hz domain SLV limiter
A244	00, 01	A241 – A243	Torque boost function
	04	H260	0Hz SLV limiter
A044	03, 04, 05	B040 – B046, H001, H070 – H072, H002, H005, H020 – H024, H030 – H034, H050 – H052, H060	Vector control
A244	03, 04	B040 – B046, H001, H070 – H072, H202, H205, H220 – H224, H230 – H234, H250 – H252, H260	Vector control
A097	01, 02, 03	A131	Acceleration pattern constant
A098	01, 02, 03	A132	Deceleration pattern constant

Function Code	Data	Resulting Non-displayed Functions (when B37 = 01)	Notes
B098	01, 02	B099, C085	Thermistor function
B050	01	B051 – B054	Instantaneous power failure
B120	01	B121 – B126	External brake control

Function Code	Data	Resulting Non-displayed Functions (when B37 = 01)	Notes
C021 – C025, C026	02, 06	C042, C043	Frequency arrival signal
	03	C040, C041	Overload advance notice
	07	C055 – C058	Over-torque
	21	C063	Zero-speed detection signal
	24, 25	C045, C046	Frequency arrival signal
	26	C011	Overload advance notice 2
H002	00	H020 – H024	Motor constant
	01, 02	H030 – H034	Motor constant (auto-tuning)
H202	00	H220 – H224	Motor constant
	01, 02	H023 – H0234	Motor constant (auto-tuning)
P010	01	P011 – P023, P025 – P027	Expansion card function

Func. Code	Name/Description	Keypad		Range and Settings	Defaults			Run Mode Edit Lo Hi
		SRW	OPE		FEF2 FE2 (EU)	FUF2 FU2 (USA)	FF2 F2 (Jpn)	
B040	Torque limit selection	4-SET	00	4-quadrant mode	00	00	00	X ✓
		TM	01	Selected by two input terminals (see p. 4-30)				
		O2	02	From analog [O2] input (0 to 10V = 0 to 200%)				
		OP1	03	From expansion card 1				
		OP2	04	From expansion card 2				
B041	Torque limit (1) (forward-driving in 4-quadrant mode)	150%	150	0. to 200. (%)	150.	150.	150.	X ✓
		no	no	Disable torque limit				
B042	Torque limit (2) (reverse-regenerating in 4-quadrant mode)	150%	150	0. to 200. (%)	150.	150.	150.	X ✓
		no	no	Disable torque limit				
B043	Torque limit (3) (reverse-driving in 4-quadrant mode)	150%	150	0. to 200. (%)	150.	150.	150.	X ✓
		no	no	Disable torque limit				
B044	Torque limit (4) (forward-regenerating in 4-quadrant mode)	150%	150	0. to 200. (%)	150.	150.	150.	X ✓
		no	no	Disable torque limit				

Func. Code	Name/Description	Keypad		Range and Settings	Defaults			Run Mode Edit Lo Hi
		SRW	OPE		FEF2 FE2 (EU)	FUF2 FU2 (USA)	FF2 F2 (Jpn)	
B045	Torque limit LADSTOP enable	OFF	00	Disable	00	00	00	x ✓
	Temporarily stops accel/decel ramps during torque limit. Available for SLV, 0 Hz domain, or vector control with feedback mode	ON	01	Enable				x ✓
B046	Reverse Run protection enable	OFF	00	Disable	00	00	00	x ✓
	Prohibits reverse motor rotation	ON	01	Enable				

Controlled Deceleration at Power Loss – When enabled, this feature permits the inverter to control final motor deceleration upon loss of inverter input power. First, you must make a wiring change to the inverter. See [“Optional Controlled Decel and Alarm at Power Loss” on page 4-4](#) for complete instructions including wiring and signal timing diagrams for using the *controlled deceleration at power loss* feature.

After making the wiring change, use function B050 to enable the feature. Use B051 to determine the point at which a decaying DC bus voltage will trigger the controlled deceleration. Use parameter B054 to specify an initial step-wise deceleration at power loss, and B053 to specify the duration of the linear deceleration.

During the controlled deceleration the inverter itself acts as a load to decelerate the motor. With either a high-inertia load or a short deceleration time (or both), it is possible that the inverter impedance will not be low enough to continue linear deceleration and avoid an over-voltage condition on the DC bus. Use parameter B052 to specify a threshold for the over-voltage. In this case, the inverter pauses deceleration (runs at constant speed). When the DC bus decays again below the threshold, linear deceleration resumes. The pause/resume process will repeat as necessary until the DC bus energy is depleted (under-voltage condition occurs).

The case when setting B052 is lower than the inverter supply voltage has special considerations:

- If B052 Over-voltage Threshold During Power Loss is less than B051 DC Bus Voltage Trigger Level During Power Loss, the over-voltage threshold during power loss will be increased to the DC bus voltage trigger level with the stop level is applied. However, the parameter setting will not be changed.
- When B052 is less than the supply voltage (the rectified DC voltage or the AC voltage times square root of two), when power recovers the inverter will be in the LAD-stop state and cannot decelerate. (The Stop Command and frequency change command are ignored until deceleration is complete.) be sure to set B052 higher than the standard supply voltage.
- A non-stop deceleration function cannot be canceled until it is complete. To restart the inverter operations after power recovery, wait until the inverter stops. Then enter a Stop Command and then an operation command (FW, RV).
- Setting a higher value for B054 Initial Output Frequency Decrease During Power Loss results in an over-current trip due to sudden deceleration. Setting a lower value for B054 or larger value for B053 Deceleration Time Setting During Power Loss results in under-voltage trip due to reduced regenerative energy.

Non-stop deceleration at instantaneous power failure (B050=01) has these characteristics:

- The nonstop deceleration at instantaneous power failure is the function making the inverter decelerate and stop the motor while maintaining the voltage below the overvoltage level (over-voltage threshold during power loss [b052]) when an instantaneous power failure occurs during the inverter operation.
- To use this function, remove the J51 connector cables from terminals R0 and T0, connect the main circuit terminals P and R0 to each other, and connect the main circuit terminals N and T0 to each other. Use 0.75 mm² or heavier wires for the connections.

- If an instantaneous power failure has occurred while the inverter is operating the motor and the output voltage falls to the DC bus voltage trigger level during power loss (b051) or less, the inverter reduces the output frequency by the initial output frequency decrease during power loss (b054) once, and then decelerates the motor for the deceleration time setting during power loss (b053).
- If the voltage increases to an overvoltage level (exceeding the over-voltage threshold during power loss [b052]) because of regeneration, the inverter enters the LAD stop state (decelerate to stop) until the voltage falls below the overvoltage level.

If the over-voltage threshold during power loss (B052) is less than the DC bus voltage trigger level during power loss (B051), the over-voltage threshold during power loss will be increased to the DC bus voltage trigger level during power loss when the stop level is applied. (However, the stored setting will not be changed.) And, in case B052 is lower than the supply voltage (equivalent to rectified DC voltage which is square root of 2 times the supply AC voltage), when power recovers while this function is activated, inverter will be in the LAD stop status and cannot decelerate. (Stop command and frequency change command are not accepted until deceleration is complete). Be sure to set b052 higher than the normal supply voltage.

Func. Code	Name/Description	Keypad		Range and Settings	Defaults			Run Mode Edit Lo Hi
		SRW	OPE		FEF2 FE2 (EU)	FUF2 FU2 (USA)	FF2 F2 (Jpn)	
B050	Controlled deceleration and stop on power loss	OFF	00	Disable	00	00	00	XX
	Allows inverter control using regenerative energy to decelerate after loss of input power (requires jumper change)	DEC	01	Constant decel to stop				XX
		NS1	02	Constant DC voltage control with resume				XX
		NS2	03	Constant DC voltage control				XX
B051	DC bus voltage trigger level during power loss			0.0 to 999.9, 1000. (V)	220.0/440.0	220.0/440.0	220.0/440.0	XX
	Sets trigger for controlled deceleration and stop on power loss function							
B052	Over-voltage threshold during power loss			0.0 to 999.9, 1000. (V)	360.0/720.0	360.0/720.0	360.0/720.0	XX
	Sets over-voltage threshold for controlled deceleration function							
B053	Deceleration time setting during power loss			0.01 to 99.99, 100.0 to 999.9, 1000 to 3600 (seconds)	1.00	1.00	1.00	XX
B054	Initial output frequency decrease during power loss			0.00 to 10.00 (Hz)	0.00	0.00	0.00	XX
	Sets the initial decrease in output frequency upon power loss							
B055	Proportional gain setting for non-stop operation at power loss			0.00 to 2.55	0.20	0.20	0.20	XX
B056	Integral time setting for non-stop operation at power loss			0.0 to 9.999, 10.00 to 65.55	0.10	0.10	0.10	XX

Window Comparators

The window comparator function controls digital outputs based on the comparison of analog input values to user-defined upper and lower limits.

Func. Code	Name/Description	Keypad		Range and Settings	Defaults			Run Mode Edit Lo Hi
		SRW	OPE		xFE2 (EU)	xFU2 (USA)	xFF2 (Jpn)	
B060	[O] input maximum limit level of window comparator			0. to 100. (%) Lower limit = B061 + B062 x 2	100	100	100	✗ ✓
B061	[O] input minimum limit level of window comparator			0. to 100. (%) Lower limit = B060 – B062 x 2	0	0	0	✗ ✓
B062	[O] input hysteresis width of window comparator			0. to 10. (%) Lower limit = B061 – B062 x 2	0	0	0	✗ ✓
B063	[OI] input maximum limit level of window comparator			0. to 100. (%) Lower limit = B064 + B066 x 2	100	100	100	✗ ✓
B064	[OI] input minimum limit level of window comparator			0. to 100. (%) Lower limit = B063 – B066 x 2	0	0	0	✗ ✓
B065	[OI] input hysteresis width of window comparator			0. to 10. (%) Lower limit = B063 – B064 x 2	0	0	0	✗ ✓
B066	[O2] input maximum limit level of window comparator			–100. to 100. (%) Lower limit = B067 + B068 x 2	100	100	100	✗ ✓
B067	[O2] input minimum limit level of window comparator			–100. to 100. (%) Lower limit = B066 – B068 x 2	-100	-100	-100	✗ ✓
B068	[O2] input hysteresis width of window comparator			0. to 10. (%) Lower limit = B066 – B067 x 2	0	0	0	✗ ✓
B070	[O] input disconnect threshold	—	—	0 to 100 (%)	255	255	255	✗ ✓
		no	255	Ignore setting				✗ ✓
B071	[OI] input disconnect threshold	—	—	0 to 100 (%)	255	255	255	✗ ✓
		no	255	Ignore setting				✗ ✓
B072	[O2] input disconnect threshold	—	—	0 to 100 (%)	127	127	127	✗ ✓
		no	127	Ignore setting				✗ ✓

Miscellaneous Functions

B083: Carrier frequency adjustment – The internal *switching frequency* of the inverter circuitry (also called the *chopper frequency*). It is called the carrier frequency because the lower AC output frequency of the inverter “rides” the carrier. The faint, high-pitched sound you hear when the inverter is in Run Mode is characteristic of switching power supplies in general. The carrier frequency is adjustable from 500 Hz to 15 kHz (the upper limit varies, depending on the inverter rating). The audible sound decreases at the higher frequencies, but RFI noise and leakage current may be increased. Refer to the specification derating curves in Chapter 1 to determine the maximum allowable carrier frequency setting for your particular inverter and environmental conditions.



NOTE: When the inverter is in sensorless vector mode, use B083 to set the carrier frequency greater than 2.1 kHz for proper operation.



NOTE: The carrier frequency setting must stay within specified limits for inverter-motor applications that must comply with particular regulatory agencies. For example, a European CE-approved application requires the inverter carrier to be less than 5 kHz.

B084, B085: Initialization codes – These functions allow you to restore the factory default settings. Please refer to “[Restoring Factory Default Settings](#)” on page 6-16.

B086: Frequency display scaling – You can convert the output frequency monitor on D001 to a scaled number (engineering units) monitored at function D007. For example, the motor may run a conveyor that is monitored in feet per minute. Use this formula:

$$\text{Scaled output frequency (D007)} = \text{Output frequency (D001)} \times \text{Factor (B086)}$$

Func. Code	Name/ Description	Keypad		Range and Settings	Defaults			Run Mode Edit Lo Hi
		SRW	OPE		FEF2 FE2 (EU)	FUF2 FU2 (USA)	FF2 F2 (Jpn)	
B078	Clear cumulative input power data	CHT	00	No change	00	00	00	✓✓
	Set = 01, press STR key to clear	CLR	01	Clear the data				
B079	Cumulative input power display gain setting			1. to 1000.	1.	1.	1.	✓✓
B082	Start frequency adjustment			0.10 to 9.99 (Hz)	0.50	0.50	0.50	✗✓
	Sets the starting frequency for the inverter output							
B083	Carrier frequency setting			Most models, 0.5 to 15.0 (kHz); -1850 and -3150 are 0.5 to 10 (kHz); -4000 is 0.5 to 3 (kHz)	3.0 2.1 1.9	3.0 2.1 1.9	3.0 2.1 1.9	✗✓
	Sets the PWM carrier (internal switching freq.); all models are subject to derating							✗✓
B084	Initialization mode (parameters or trip history)	TRP	00	Trip history clear	00	00	00	✗✗
		DATA	01	Parameter initialization				
		TRP/ DATA	02	Trip history clear and parameter initialization				
B085	Country code for initialization	JPN	00	Japan version	01	02	00	✗✗
	Select default parameter values for country on initialization	EUR	01	Europe version				
		USA	02	USA version				
B086	Frequency scaling conversion factor			0.1 to 99.9	1.0	1.0	1.0	✓✓
	Specify a constant to scale D007 to display in engineering units							
B087	STOP key enable	ON	00	Enable	00	00	00	✗✓
	Select whether the STOP key on the keypad is enabled (req. A002=01, 03, 04, or 05)	OFF	01	Disable				
		S-OFF	02	Disable only the STOP function				

B091/B088: Stop Mode / Restart Mode Configuration – You can configure how the inverter performs a standard stop (each time Run FWD and REV signals turn OFF). Setting B091 determines whether the inverter will control the deceleration, or whether it will perform a free-run stop (coast to a stop). When using the free-run stop selection, it is imperative to also configure how you want the inverter to resume control of motor speed. Setting B088 determines whether the inverter will ensure the motor always resumes at 0 Hz, or whether the motor resumes from its current coasting speed (also called *frequency matching*). The Run command may turn OFF briefly, allowing the motor to coast to a slower speed from which normal operation can resume.

In most applications a controlled deceleration is desirable, corresponding to B091=00. However, applications such as HVAC fan control will often use a free-run stop (B091=01). This practice decreases dynamic stress on system components, prolonging system life. In this case, you will typically set B088=01 in order to resume from the current speed after a free-run stop (see diagram below, right). Note that using the default setting, B088=00, can cause trip events when the inverter attempts to force the load quickly to zero speed.



NOTE: Other events can cause (or be configured to cause) a free-run stop, such as power loss (see “Automatic Restart Mode and Phase Loss” on page 3-30), and inverter trip events in general (see “Miscellaneous Functions” on page 3-62). If all free-run stop behavior is important to your application (such as HVAC), be sure to configure each event accordingly.

Some additional parameters further configure all instances of a free-run stop. Parameter B003, Retry Wait Time Before Motor Restart, sets the minimum time the inverter will free-run. For example, if B003 = 4 seconds (and B091=01) and the cause of the free-run stop lasts 10 seconds, the inverter will free-run (coast) for a total of 14 seconds before driving the motor again. Parameter B007, Restart Frequency Threshold, sets the motor frequency at which the inverter will no longer resume and accelerate, instead resuming from 0 Hz (complete stop).

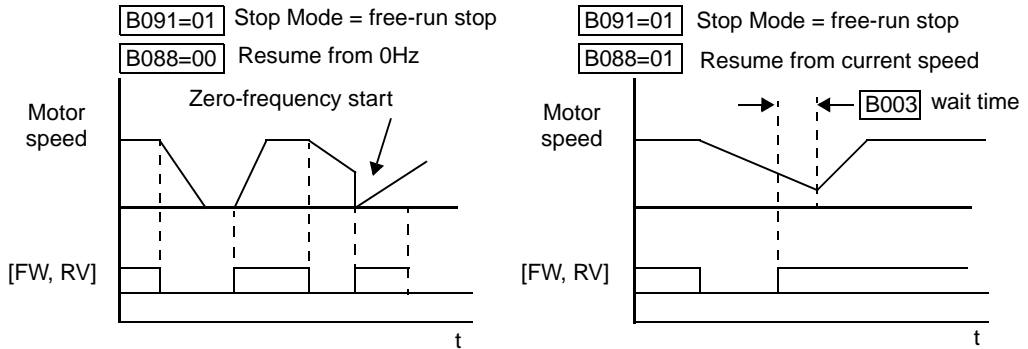

Configuring Drive Parameters

Func. Code	Name/Description	Keypad		Range and Settings	Defaults			Run Mode Edit Lo Hi
		SRW	OPE		FEF2 FE2 (EU)	FUF2 FU2 (USA)	FF2 F2 (Jpn)	
B088	Restart mode after FRS	ZST	00	Restart from 0Hz	00	00	00	X ✓
	Selects how the inverter resumes operation when the free-run stop (FRS) is cancelled	fST	01	Restart from frequency detected from actual speed of motor				
		FIx	02	Restart from active matching frequency				
B089	Automatic carrier frequency reduction	OFF	00	Disable	00	00	00	X ✓
		ON	01	Enable				X ✓
B090	Dynamic braking usage ratio			0.0 to 100.0 (%) Set = 0.0 to disable dynamic braking	00	00	00	X ✓
	Selects the braking duty cycle for the dynamic braking resistor (total brake % ON-time per 100 second interval)							X ✓
B091	Stop mode selection	DEC	00	DEC (decelerate and stop)	00	00	00	X X
	Selects how the inverter stops the motor	FRS	01	FRS (free run to stop)				X X
B092	Cooling fan control (see note below)	OFF	00	Fan always ON	00	00	00	X X
		ON	01	Fan ON during RUN, OFF during STOP				X X
B095	Dynamic braking control	OFF	00	Disable	00	00	00	X ✓
		ON STPOFF	01	Enable during RUN only				X ✓
		ON STPON	02	Enable always				X ✓

Func. Code	Name/Description	Keypad		Range and Settings	Defaults			Run Mode Edit Lo Hi
		SRW	OPE		FEF2 FE2 (EU)	FUF2 FU2 (USA)	FF2 F2 (Jpn)	
B096	Dynamic braking activation level			330 to 380 (V) (200V class), 660 to 760 (V) (400V class)	360/720	360/720	360/720	✗ ✓
B098	Thermistor for thermal protection control	OFF	00	Disable	00	00	00	✗ ✓
		PTC	01	Enable-PTC thermistor				✗ ✓
		NTC	02	Enable-NTC thermistor				✗ ✓
B099	Thermal protection level setting			0.0 to 9999 Ohms	3000	3000	3000	✗ ✓
	Thermistor resistance threshold at which trip occurs							✗ ✓

B090: Dynamic braking usage ratio – This parameter limits the amount of time the inverter can use the dynamic braking accessory device without entering the Trip Mode. Please refer to [“Dynamic Braking” on page 5-6](#) for more information on dynamic braking accessories.



NOTE: When cooling fan control is enabled (B092=01) the inverter always turns the fan ON for five minutes immediately after powerup. This will cool the inverter in case the inverter / motor is still warm from prior running before a short power outage.

Free-setting V/f Pattern

The free-setting V/f inverter mode of operation uses voltage and frequency parameter pairs to define seven points on a V/f graph. This provides a way to define a multi-segment V/f curve that best suits your application.

The frequency settings do require that $F1 \leq F2 \leq F3 \leq F4 \leq F5 \leq F6 \leq F7$; their values must have this ascending order relationship. To satisfy this criterion during initial parameter editing, set F7 (B112) and work backwards when setting these values, since the defaults are all 0 Hz. However, the voltages V1 to V7 may either increase or decrease from one to the next. Therefore, you may set these parameters in any order.

Func. Code	Name/Description	Range and Settings	Defaults			Run Mode Edit Lo Hi
			FEF2 FE2 (EU)	FUF2 FU2 (USA)	FF2 F2 (Jpn)	
B100	Free-setting V/f frequency (1)	0. to Free-setting V/f frequency (2) (Hz)	0.	0.	0.	✗ ✗
B101	Free-setting V/f voltage (1)	0.0 to 800.0 (V)	0.0	0.0	0.0	✗ ✗
B102	Free-setting V/f frequency (2)	0. to Free-setting V/f frequency (3) (Hz)	0.	0.	0.	✗ ✗
B103	Free-setting V/f voltage (2)	0.0 to 800.0 (V)	0.0	0.0	0.0	✗ ✗
B104	Free-setting V/f frequency (3)	0. to Free-setting V/f frequency (4) (Hz)	0.	0.	0.	✗ ✗
B105	Free-setting V/f voltage (3)	0.0 to 800.0 (V)	0.0	0.0	0.0	✗ ✗
B106	Free-setting V/f frequency (4)	0. to Free-setting V/f frequency (5) (Hz)	0.	0.	0.	✗ ✗
B107	Free-setting V/f voltage (4)	0.0 to 800.0 (V)	0.0	0.0	0.0	✗ ✗
B108	Free-setting V/f frequency (5)	0. to Free-setting V/f frequency (6) (Hz)	0.	0.	0.	✗ ✗
B109	Free-setting V/f voltage (5)	0.0 to 800.0 (V)	0.0	0.0	0.0	✗ ✗
B110	Free-setting V/f frequency (6)	0. to Free-setting V/f frequency (7) (Hz)	0.	0.	0.	✗ ✗
B111	Free-setting V/f voltage (6)	0.0 to 800.0 (V)	0.0	0.0	0.0	✗ ✗
B112	Free-setting V/f frequency (7)	0. to 400.0 (Hz)	0.	0.	0.	✗ ✗
B113	Free-setting V/f voltage (7)	0.0 to 800.0 (V)	0.0	0.0	0.0	✗ ✗

Configuring Drive Parameters

External Brake Control

The brake control function in the inverter controls external braking used in systems such as elevators. The purpose of this function is to ensure the inverter is powering the motor before releasing external brakes that would permit the load to move or coast. This function requires the configuration and wiring of intelligent input and output terminals. See ["External Brake Control Function" on page 4-32](#) for more information.

Configuring Drive Parameters

Func. Code	Name/Description	Keypad		Range and Settings	Defaults			Run Mode Edit Lo Hi
		SRW	OPE		FEF2 FE2 (EU)	FUF2 FU2 (USA)	FF2 F2 (Jpn)	
B120	Brake Control Enable	OFF	00	Disable	00	00	00	x ✓
		ON	01	Enable				
B121	Brake Wait Time for Release	0.00 to 5.00 (seconds)			0.00	0.00	0.00	x ✓
	Sets time delay between arrival at release frequency and the brake release signal							
B122	Brake Wait Time for Acceleration	0.00 to 5.00 (seconds)			0.00	0.00	0.00	x ✓
	Sets time delay from receipt of brake confirmation signal to start of motor acceleration							
B123	Brake Wait Time for Stopping	0.00 to 5.00 (seconds)			0.00	0.00	0.00	x ✓
	Sets time delay from brake confirmation signal turns OFF to inverter deceleration to 0 Hz							
B124	Brake Wait Time for Confirmation	0.00 to 5.00 (seconds)			0.00	0.00	0.00	x ✓
	Sets the wait time for confirmation after turn ON/OFF of brake release. If confirmation is not received during the specified wait time, the inverter will trip with an external brake error.							
B125	Brake Release Frequency Setting	0.00 to 99.99, 100.0 to 400.0 (Hz)			0.00	0.00	0.00	x ✓
	Sets the frequency of the brake release output signal after delay set by B121							
B126	Brake Release Current Setting	0 to 1.80 x rated current			Rated current for inverter			x ✓
	Sets the minimum inverter current level above which the brake release signal is permitted							
B127	Braking Frequency	0.00 to 99.99, 100.0 to 400.0 (Hz)			0.00	0.00	0.00	x ✓

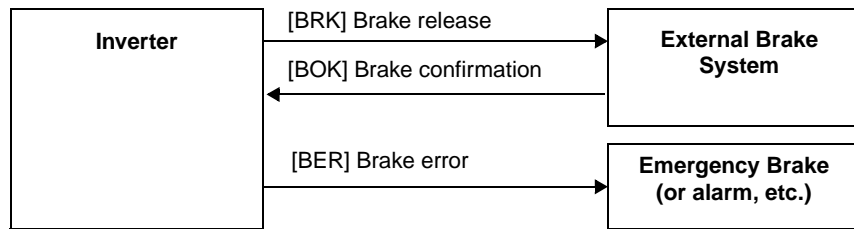

Overvoltage Functions

B130/B131: Over-voltage LADSTOP Enable / Over-voltage LADSTOP Level – The over-voltage LADSTOP function monitors the DC bus voltage and actively changes the output frequency profile to maintain the DC bus voltage within settable limits. Although “LAD” refers to “linear acceleration / deceleration,” the inverter only “STOPS” the deceleration slope so that regenerative voltage will not cause the DC bus to rise enough to cause an over-voltage trip event. Note that acceleration is not affected.

The graph below shows an inverter output profile that starts decelerating to a stop. At two different points during the deceleration, regenerative voltage elevates the DC bus level, exceeding the LADSTOP threshold set by B131. When the Over-voltage LADSTOP feature is enabled by B130 = 01, the inverter stops the deceleration ramp in each case until the DC bus level is again less than the threshold value.

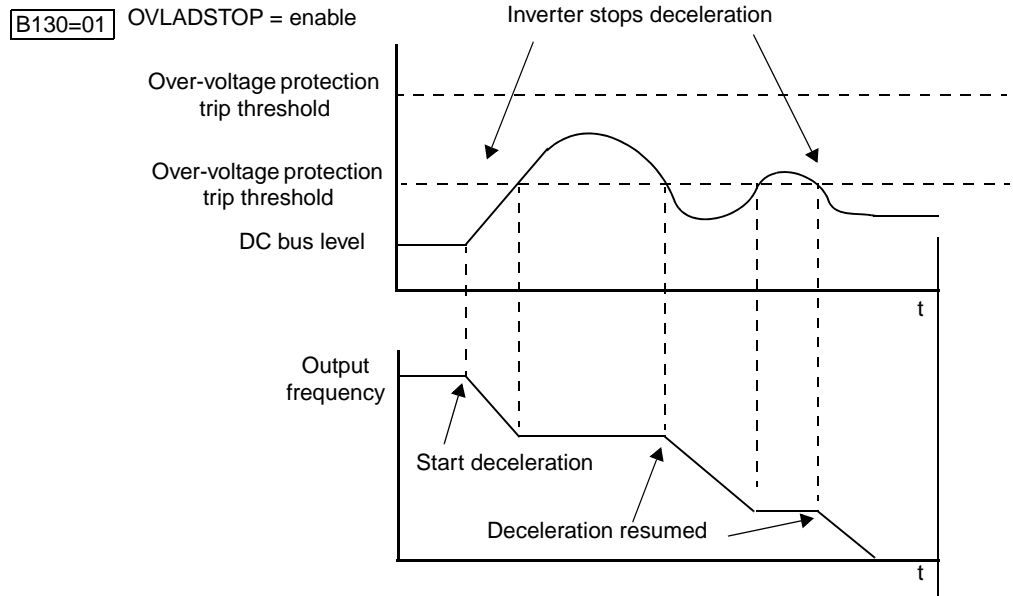

Configuring Drive Parameters

Func. Code	Name/Description	Keypad		Range and Settings	Defaults			Run Mode Edit Lo Hi
		SRW	OPE		FEF2 (EU)	FUF2 (USA)	FF2 (Jpn)	
B130	Over-voltage LADSTOP enable	OFF	00	Disable	00	00	00	XX
	Pauses deceleration ramp when DC bus voltage rises above threshold level, in order to avoid over-voltage trip	ON	01	Enable during deceleration and constant speed				XX
		AOH	02	Enable during acceleration				XX
B131	Over-voltage LADSTOP level			330 to 390 (V) for 200V class, 660 to 780 (V) for 400V class	380/760	380/760	380/760	X✓
	Sets the threshold level for over-voltage LADSTOP. When the DC bus voltage is above the threshold value, the inverter stops deceleration until the DC bus voltage is less than the threshold setting again.							X✓
B132	Acceleration and deceleration rate at overvoltage suppression			0.10 to 30.00 (seconds)	1.00	1.00	1.00	X✓
B133	Overvoltage suppression proportional gain			0.00 to 2.55	0.50	0.50	0.50	XX
B134	Overvoltage suppression integral time			0.000 to 9.999, 10.00 to 63.53 (seconds)	0.060	0.060	0.060	XX

“C” Group: Intelligent Terminal Functions

The eight input terminals [1], [2], [3], [4], [5], [6], [7], and [8] can be configured for any of 44 different functions. The next two tables show how to configure the eight terminals. The inputs are logical, in that they are either OFF or ON. We define these states as OFF=0, and ON=1.

The inverter comes with default options for the eight terminals. These default settings are initially unique, each one having its own setting. Note that European and US versions have different default settings. You can use any option on any terminal, and even use the same option twice to create a logical OR (though usually not required).

Input Terminal Configuration

Functions and Options –The *function codes* in the following table let you assign one of 44 options to any of the eight logic inputs for the SJ7002 inverters. The functions C001 through C008 configure the terminals [1] through [8] respectively. The “value” of these particular parameters is not a scalar value, but it is a discrete number that selects one option from many available *options*.

For example, if you set function C001=01, you have assigned option 01 (Reverse Run) to terminal [1]. The option codes and the specifics of how each one works are in Chapter 4.

Func. Code	Name/Description	Range and Settings	Defaults			Run Mode Edit Lo Hi
			FEF2 FE2 (EU)	FUF2 FU2 (USA)	FF2 F2 (Jpn)	
C001	Terminal [1] function	63 programmable functions available for terminals (see next section)	18 [RS]	18 [RS]	18 [RS]	✗ ✓
C002	Terminal [2] function		16 [AT]	16 [AT]	16 [AT]	✗ ✓
C003	Terminal [3] function		06 [JG]	06 [JG]	06 [JG]	✗ ✓
C004	Terminal [4] function		11 [FRS]	11 [FRS]	11 [FRS]	✗ ✓
C005	Terminal [5] function		09 [2CH]	09 [2CH]	09 [2CH]	✗ ✓
C006	Terminal [6] function		03 [CF2]	13 [USP]	03 [CF2]	✗ ✓
C007	Terminal [7] function		02 [CF1]	02 [CF1]	02 [CF1]	✗ ✓
C008	Terminal [8] function		01 [RV]	01 [RV]	01 [RV]	✗ ✓

The input logic convention is programmable for each of the six inputs. Most inputs default to normally open (active high), but you can select normally closed (active low) in order to invert the sense of the logic.

Func. Code	Name/Description	Keypad		Range and Settings	Defaults			Run Mode Edit Lo Hi
		SRW	OPE		FEF2 FE2 (EU)	FUF2 FU2 (USA)	FF2 F2 (Jpn)	
C011	Terminal [1] active state	NO	00	Normally open (N.O.)	00	00	00	✗ ✓
		NC	01	Normally closed (N.C.)				✗ ✓
C012	Terminal [2] active state	NO	00	Normally open (N.O.)	00	00	00	✗ ✓
		NC	01	Normally closed (N.C.)				✗ ✓
C013	Terminal [3] active state	NO	00	Normally open (N.O.)	00	00	00	✗ ✓
		NC	01	Normally closed (N.C.)				✗ ✓
C014	Terminal [4] active state	NO	00	Normally open (N.O.)	00	00	00	✗ ✓
		NC	01	Normally closed (N.C.)				✗ ✓

Func. Code	Name/Description	Keypad		Range and Settings	Defaults			Run Mode Edit Lo Hi
		SRW	OPE		FEF2 FE2 (EU)	FUF2 FU2 (USA)	FF2 F2 (Jpn)	
C015	Terminal [5] active state	NO	00	Normally open (N.O.)	00	00	00	X ✓
		NC	01	Normally closed (N.C.)				X ✓
C016	Terminal [6] active state	NO	00	Normally open (N.O.)	00	00	00	X ✓
		NC	01	Normally closed (N.C.)				X ✓
C017	Terminal [7] active state	NO	00	Normally open (N.O.)	00	00	00	X ✓
		NC	01	Normally closed (N.C.)				X ✓
C018	Terminal [8] active state	NO	00	Normally open (N.O.)	00	00	00	X ✓
		NC	01	Normally closed (N.C.)				X ✓
C019	Terminal [FW] active state	NO	00	Normally open (N.O.)	00	00	00	X ✓
		NC	01	Normally closed (N.C.)				X ✓



NOTE: An input terminal configured for option code 18 ([RS] Reset command) cannot be configured for normally closed operation.

Intelligent Input Terminal Overview

Each of the eight intelligent terminals may be assigned any of the options in the following table. When you program one of the option codes for terminal assignments C001 to C008, the respective terminal assumes the function role of that option code. The terminal functions have a symbol or abbreviation, which we use to label a terminal using that function. For example the “Reverse Run” command is [RV]. The physical label on the terminal block connector is simply **1, 2, 3, 4, 5, 6, 7, or 8**. However, schematic examples in this manual also use the terminal function symbol (such as [RV]) to show the assigned option. The option codes for C011 to C019 determine the active state of the logical input (active high or active low).

Summary Table - This table shows all forty-four intelligent input functions at a glance. Detailed descriptions of these functions, related parameters and settings, and example wiring diagrams are in [“Using Intelligent Input Terminals” on page 4-13](#).

Input Function Summary Table			
Option Code	Terminal Symbol	Function Name	Description
01	RV	Reverse Run/Stop	Puts the inverter in Run Mode, motor runs reverse
02	CF1	Multi-speed select, Bit 0 (LSB)	Binary encoded speed select, Bit 0
03	CF2	Multi-speed select, Bit 1	Binary encoded speed select, Bit 1
04	CF3	Multi-speed select, Bit 2	Binary encoded speed select, Bit 2
05	CF4	Multi-speed select, Bit 3 (MSB)	Binary encoded speed select, Bit 3
06	JG	Jogging	Puts the inverter in Run Mode, output to motor runs at jog parameter frequency A038
07	DB	External Signal for DC Injection Braking	Applies DC braking during deceleration

Input Function Summary Table

Option Code	Terminal Symbol	Function Name	Description
08	SET	Set (select) 2nd Motor Data	Switch from normal (1st) to 2nd motor parameters for generating frequency output to motor
09	2CH	2-stage Acceleration and Deceleration	Frequency output uses 2nd-stage acceleration and deceleration values
11	FRS	Free-run Stop	Causes output to turn OFF, allowing motor to free run (coast) to stop
12	EXT	External Trip	At OFF to ON transition, inverter latches trip event and displays E12 (until a reset occurs)
13	USP	Unattended Start Protection	On powerup, the inverter will not resume a Run command that was active before power loss (mostly used in the US)
14	CS	Commercial Power Source	OFF-to-ON transition signals the inverter that the motor is already running at powerup (via bypass), thus suppressing the inverter's motor output in Run Mode; ON-to-OFF transition signals the inverter to apply a time delay (B003), frequency match its output to existing motor speed, and resume normal Run Mode operation
15	SFT	Software Lock	The keypad and remote programming devices are prevented from changing parameters
16	AT	Analog Input Voltage/current Select	ON condition: If A005=00, terminal [OI] is enabled for input. If A005=01, terminal [O2] is enabled for input. (Use terminal [L] for signal return.) OFF condition: Terminal [O] is enabled for voltage input (use terminal [L] for signal return).
17	SET3	Set (select) 3rd motor data	Switch from normal (1st) to 3rd motor parameters for generating frequency output to motor
18	RS	Reset Inverter	Resets the trip condition, turns OFF the motor output, and asserts powerup reset
20	STA	START (3-wire interface)	Starts the motor rotation
21	STP	STOP (3-wire interface)	Stops the motor rotation
22	F/R	FWD, REV (3-wire interface)	Selects the direction of motor rotation: ON =FWD; OFF =REV. While the motor is rotating, a change of F/R will start a deceleration, followed by a change in direction.
23	PID	PID Disable	Temporarily disables PID loop control. Inverter output turns OFF as long as PID Enable is active (A071=1).
24	PIDC	PID Reset	Resets the PID loop controller. The main consequence is that the integrator sum is forced to zero.
26	CAS	Control gain setting	To select the source of internal speed loop gain... OFF selects parameters H050 to H052 (or H250 to H252 for 2nd motor); ON selects alternate parameters H070 to H072
27	UP	Remote Control UP Function (motorized speed pot.)	Accelerates (increases output frequency) motor from current frequency
28	DWN	Remote Control DOWN Function (motorized speed pot.)	Decelerates (decreases output frequency) motor from current frequency

Input Function Summary Table			
Option Code	Terminal Symbol	Function Name	Description
29	UDC	Remote Control Data Clearing	Clears the UP/DWN frequency memory by forcing it to equal the set frequency parameter F001. Setting C101 must be set=00 to enable this function to work.
31	OPE	Operator Control	Forces the source of the output frequency setting (A001) and the RUN command (A002) to be from the digital operator (F001 and the Run key, respectively)
32	SF1	Multi-speed bit 1	Multiple speed select, Bit 1
33	SF2	Multi-speed bit 2	Multiple speed select, Bit 2
34	SF3	Multi-speed bit 3	Multiple speed select, Bit 3
35	SF4	Multi-speed bit 4	Multiple speed select, Bit 4
36	SF5	Multi-speed bit 5	Multiple speed select, Bit 5
37	SF6	Multi-speed bit 6	Multiple speed select, Bit 6
38	SF7	Multi-speed bit 7	Multiple speed select, Bit 7
39	OLR	Overload restriction	Turn ON to select current overload parameter set 2 (B024, B025, B026); OFF selects set 1(B021, B022, B023)
40	TL	Torque limit enable	ON enables torque limit feature; OFF disables all torque limit sources and defaults to 200% of inverter rated torque output
41	TRQ1	Torque limit selection, bit 1	Binary encoded torque limit select, Bit 1 (LSB)
42	TRQ2	Torque limit selection, bit 2	Binary encoded torque limit select, Bit 2 (MSB)
43	PPI	Proportional / Proportional/Integral mode selection	ON selects Proportional-only control; OFF selects Proportional-Integral control
44	BOK	Brake confirmation signal	Indicates external brake has released (used only for external brake control function)
45	ORT	Orientation (home search)	The encoder is in the home (oriented) position
46	LAC	LAC: LAD cancel	Disables the normal Linear Accel / Decel (LAD) mode
47	PCLR	Position deviation reset	Clears the position deviation by setting the actual position equal to the desired position
48	STAT	Pulse train position command input enable	Enables the pulse train control of motor
50	ADD	Add frequency enable	Adds the A145 value (Add Frequency) to the output frequency
51	F-TM	Force terminal mode	Force inverter to use input terminals for output frequency and Run command sources
52	ATR	Torque control enable	Inverter operates by controlling torque instead of speed
53	KHC	Clear cumulative power value	Clears cumulative power data displayed by parameter D015
54	SON	Speed servo ON	Enables the inverter to accept FW/REV commands; for use with V/F curve <i>vector control with sensor</i> (A044=05)

Input Function Summary Table

Option Code	Terminal Symbol	Function Name	Description
55	FOC	Current forcing	Forces excitation current in motor at 0 speed; for use with V/f curve settings A044/A244 = 03, 04, and 05
56	MI1	General-purpose input 1	Easy sequence function, general input 1
57	MI2	General-purpose input 2	Easy sequence function, general input 2
58	MI3	General-purpose input 3	Easy sequence function, general input 3
59	MI4	General-purpose input 4	Easy sequence function, general input 4
60	MI5	General-purpose input 5	Easy sequence function, general input 5
61	MI6	General-purpose input 6	Easy sequence function, general input 6
62	MI7	General-purpose input 7	Easy sequence function, general input 7
63	MI8	General-purpose input 8	Easy sequence function, general input 8
65	AHD	Analog holding command	Causes the inverter to sample and hold the analog speed input, maintaining constant speed while this signal is ON
66	CP1	Multi-stage position select 1	Binary-encoded position select, bit 1 (LSB)
67	CP2	Multi-stage position select 2	Binary-encoded position select, bit 2 (LSB)
68	CP3	Multi-stage position select 3	Binary-encoded position select, bit 3 (MSB)
69	ORL	Zero-return limit function	Indicates that the load has reached the zero-return point, so the inverter stops the zero-return operation in progress
70	ORG	Zero-return trigger function	Starts a zero-return operation (load moves toward the zero-return point)
71	FOT	Forward drive stop	Limits the forward rotational torque to 10%; for use at the end of travel in position control mode
72	ROT	Reverse drive stop	Limits the reverse rotational torque to 10%; for use at the end of travel in position control mode
73	SPD	Speed/position control select	Causes the inverter to perform only speed control (ignores encoder pulses) while in position control mode
74	PCNT	Pulse counter input	Pulse counter input
75	PCC	Pulse counter clear	Clears the pulse count
no	—	Not selected	(input ignored)

Output Terminal Configuration

The inverter provides configuration for logic (discrete) and analog outputs, shown in the table below.

Func. Code	Name/ Description	Range and Settings	Defaults			Run Mode Edit Lo Hi
			FEF2 FE2 (EU)	FUF2 FU2 (USA)	FF2 F2 (Jpn)	
C021	Terminal [11] function *	51 programmable functions available for logic (discrete) outputs (see next section)	01 [FA1]	01 [FA1]	01 [FA1]	✗ ✓
C022	Terminal [12] function *		00 [RUN]	00 [RUN]	00 [RUN]	✗ ✓
C023	Terminal [13] function *		03 [OL]	03 [OL]	03 [OL]	✗ ✓
C024	Terminal [14] function *		07 [OTQ]	07 [OTQ]	07 [OTQ]	✗ ✓
C025	Terminal [15] function		08 [IP]	08 [IP]	08 [IP]	✗ ✓
C026	Alarm relay terminal function		05 [AL]	05 [AL]	05 [AL]	✗ ✓
C027	[FM] signal selection	12 programmable functions available for analog outputs (see after next section)	00 (output freq.)			✗ ✓
C028	[AM] signal selection		00 (output freq.)			✗ ✓
C029	[AMI] signal selection		00 (output freq.)			✗ ✓
C030	Digital current monitor reference value	0.20 x rated current to 2.00 x rated current (A)	Rated current x 1.0			✓ ✓
	Current with digital current monitor output at 1.44 kHz					✓ ✓



NOTE: *Terminals [11] – [13] or [11] – [14] are automatically configured as AC0 – AC2 or AC0 – AC3 when C62 is configured to enable alarm code output.

The output logic convention is programmable for terminals [11] – [15], and the alarm relay terminals. The open-collector output terminals [11] – [15] default to normally open (active low), but you can select normally closed (active high) for the terminals in order to invert the sense of the logic. You can invert the logical sense of the alarm relay output as well.

Func. Code	Name/ SRW Display	Keypad		Range and Settings	Defaults			Run Mode Edit Lo Hi
		SRW	OPE		FEF2 FE2 (EU)	FUF2 FU2 (USA)	FF2 F2 (Jpn)	
C031	Terminal [11] active state	NO	00	Normally open (N.O.)	00	00	00	✗ ✓
		NC	01	Normally closed (N.C.)				
C032	Terminal [12] active state	NO	00	Normally open (N.O.)	00	00	00	✗ ✓
		NC	01	Normally closed (N.C.)				
C033	Terminal [13] active state	NO	00	Normally open (N.O.)	00	00	00	✗ ✓
		NC	01	Normally closed (N.C.)				
C034	Terminal [14] active state	NO	00	Normally open (N.O.)	00	00	00	✗ ✓
		NC	01	Normally closed (N.C.)				
C035	Terminal [15] active state	NO	00	Normally open (N.O.)	00	00	00	✗ ✓
		NC	01	Normally closed (N.C.)				
C036	Alarm relay terminal active state	NO	00	Normally open (N.O.)	01	01	01	✗ ✓
		NC	01	Normally closed (N.C.)				

Output Summary Table - This table shows all twenty-two functions for the logic output terminals [11] – [15] at a glance. Detailed function descriptions, related parameters, settings, and example wiring diagrams are in [“Using Intelligent Output Terminals” on page 4-43](#).

Output Function Summary Table			
Option Code	Terminal Symbol	Function Name	Description
00	RUN	Run signal	Inverter is in Run Mode, motor running
01	FA1	Frequency arrival type 1 – constant speed	When output to motor is at the standard set frequency F001
02	FA2	Frequency arrival type 2 – over-frequency	Turns ON when output to motor is at or above the FA Threshold 1 (C042) during accel; turns OFF when motor output goes below the threshold during decel
03	OL	Overload advance notice signal (1)	Output current is more than the set Threshold 1 for the overload signal (set with C041)
04	OD	Output deviation for PID control	PID error is more than the set threshold for the deviation signal
05	AL	Alarm signal	Alarm condition has been met and not reset
06	FA3	Frequency arrival type 3 – at frequency	Output to motor is at the FA Threshold 1 (C042) during accel, or at C043 during decel
07	OTQ	Over-torque signal	Over-torque feature is enabled and the motor is generating excess torque
08	IP	Instantaneous power failure signal	Inverter input power has decreased below the acceptable input voltage level
09	UV	Under-voltage signal	Inverter input power has decreased below the acceptable input voltage level
10	TRQ	In torque limit	Output torque exceeds level set for the particular torque/frequency quadrant in effect during operation
11	RNT	Operation time over	Inverter Run time exceeds the limit set by Run/power-on warning time (B034)
12	ONT	Plug-in time over	Inverter plug-in time exceeds the set limit
13	THM	Thermal alarm signal	Thermal limit for the motor is exceeded
19	BRK	Brake release signal	ON when the inverter signals the external braking system to release (open) its brake; OFF when the inverter is not driving the motor and needs the external brake engaged
20	BER	Brake error signal	ON when the output current is less than the set releasing current; OFF when the braking function is not in use, or when the output current to the motor is correct and it is safe to release the brake
21	ZS	Zero speed detect	Encoder pulses of the motor have stopped
22	DSE	Speed deviation maximum	Velocity error exceeds the error threshold defined for the encoder input
23	POK	Positioning completion	Load position is at the target
24	FA4	Frequency arrival type 4 – over-frequency (2)	ON when output to motor is at or above the FA threshold 2 (C045) during accel; OFF when the output to motor is below the FA threshold 2 (C046) during decel
25	FA5	Frequency arrival type 5 – at frequency (2)	Output to motor is at the FA threshold 2 (C045) during accel or at C046 during decel

Output Function Summary Table			
Option Code	Terminal Symbol	Function Name	Description
26	OL2	Overload notice advance signal (2)	Output current is more than the set Threshold 2 for the overload signal (set with C111)
27	Odc	Analog [O] disconnect detect	Input signal level at terminal [O] is below threshold (set with B070)
28	OIDc	Analog [OI] disconnect detect	Input signal level at terminal [OI] is below threshold (set with B071)
29	O2Dc	Analog [O2] disconnect detect	Input signal level at terminal [O2] is below threshold (set with B072)
31	FBV	PID feedback second stage output	Stage #1 inverter is indicating to Stage # inverter that the Process Variable (PV) is in saturation. The system needs Stage #2 output contribution to stabilize system control.
32	NDc	Network detection signal	The communications watchdog timer (period specified by C077) has timed out
33	LOG1	Logic output 1	Boolean operation specified by C144 has a logical "1" result
34	LOG2	Logic output 2	Boolean operation specified by C147 has a logical "1" result
35	LOG3	Logic output 3	Boolean operation specified by C150 has a logical "1" result
36	LOG4	Logic output 4	Boolean operation specified by C153 has a logical "1" result
37	LOG5	Logic output 5	Boolean operation specified by C156 has a logical "1" result
38	LOG6	Logic output 6	Boolean operation specified by C159 has a logical "1" result
39	WAC	Capacitor life warning	Capacitor bank on the main board needs replacement
40	WAF	Low cooling fan speed	Cooling fan is enabled but it is rotating below normal speed
41	FR	Starting contact signal	ON while the inverter receives a FW or REV command
42	OHF	Heat sink overheat warning	Inverter heat sink temperature is above the threshold set by C064
43	LOC	Low output current signal	Output current to motor is below threshold set by C039
44	MO1	General output 1	Easy sequence function, general output 1
45	MO2	General output 2	Easy sequence function, general output 2
46	MO3	General output 3	Easy sequence function, general output 3
47	MO4	General output 4	Easy sequence function, general output 4
48	MO5	General output 5	Easy sequence function, general output 5
49	MO6	General output 6	Easy sequence function, general output 6
50	IRDY	Inverter ready signal	Inverter is ready to accept commands (FW, REV, JOG, etc.)
51	FWR	Forward rotation signal	Inverter output is driving motor in forward direction
52	RVR	Reverse rotation signal	Inverter output is driving motor in reverse direction
53	MJA	Major failure signal	Inverter trip caused by internal hardware error
54	WCO	[O] terminal window comparator	[O] input is within comparator window set by B060 and B061
55	WCOI	[OI] terminal window comparator	[OI] input is within comparator window set by B063 and B064

Output Function Summary Table			
Option Code	Terminal Symbol	Function Name	Description
56	WCO2	[O2] terminal window comparator	[O2] input is within comparator window set by B066 and B067

Analog Summary Table - The following tables show all functions available for assignment to the three analog output terminals [FM], [AM], [AMI] at a glance. Detailed descriptions, related parameters, and settings are in ["Analog Output Operation" on page 4-66](#).

C027 Setting for Terminal FM			
Option Code	Function Name	Description	Corresponding Signal Range
00	Output frequency	Actual motor speed, represented by PWM signal	0 to max. frequency in Hz
01	Output current	Motor current (% of maximum rated output current), represented by PWM signal	0 to 200%
02	Output torque	Rated output torque	0 to 200%
03	Digital output frequency	Output frequency (available only at FM output)	0 to max. frequency in Hz
04	Output voltage	Rated output voltage to motor	0 to 100%
05	Input power	Rated input power	0 to 200%
06	Electronic thermal overload	Percentage of electronic overload attained	0 to 100%
07	LAD frequency	Internal ramp generator frequency	0 to max. frequency in Hz
08	Digital current monitor	Signal freq. = 1,440 Hz when output current = C030 setting	0.2 x rated current to 2.0 x rated current (A)
09	Motor temperature	Thermistor input temp. reading in PWM format	0 to 200°C
10	Heat sink temperature	Inverter heatsink temp. reading in PWM format	0 to 200°C
12	General YA(0) analog output	Internal analog value from EZ-Sequence	0 to 100%

C028 Setting for Terminal [AM]; C029 Setting for Terminal [AMI]			
Option Code	Function Name	Description	Corresponding Signal Range
00	Output frequency	Actual motor speed, represented by PWM signal	0 to max. frequency in Hz
01	Output current	Motor current (% of maximum rated output current), represented by PWM signal	0 to 200%
02	Output torque	Rated output torque	0 to 200%
03	Digital output frequency	Output frequency (available only at FM output)	0 to max. frequency in Hz
04	Output voltage	Rated output voltage to motor	0 to 100%

C028 Setting for Terminal [AM]; C029 Setting for Terminal [AMI]			
Option Code	Function Name	Description	Corresponding Signal Range
05	Input power	Rated input power	0 to 200%
06	Electronic thermal overload	Percentage of electronic overload attained	0 to 100%
07	LAD frequency	Internal ramp generator frequency	0 to max. frequency in Hz
09	Motor temperature	Thermistor input temp. reading in PWM format	0 to 200°C
10	Heat sink temperature	Inverter heatsink temp. reading in PWM format	0 to 200°C
13	General YA(1) analog output	Internal analog value from EZ-Sequence	0 to 100% (output only from terminal [AM])
14	General YA(2) analog output	Internal analog value from EZ-Sequence	0 to 100% (output only from terminal [AMI])

Output Function Adjustment Parameters

The following parameters work in conjunction with the intelligent output function, when configured. The overload level parameter (C041) sets the motor current level at which the overload signal [OL] turns ON. The range of settings is from 0% to 200% of the rated current for the inverter. This function is for generating an early warning logic output, without causing either a trip event or a restriction of the motor current (those effects are available on other functions).

The frequency arrival signal, [FA1] to [FA5], is intended to indicate when the inverter output has reached (arrived at) the target frequency. You can adjust the timing of the leading and trailing edges of the signal via two parameters specific to acceleration and deceleration ramps, C042 and C043.

The Error for the PID loop is the magnitude (absolute value) of the difference between the Setpoint (desired value) and Process Variable (actual value). The PID output deviation signal [OD] (output terminal function option code 04) indicates when the error magnitude has exceeded a magnitude you define.

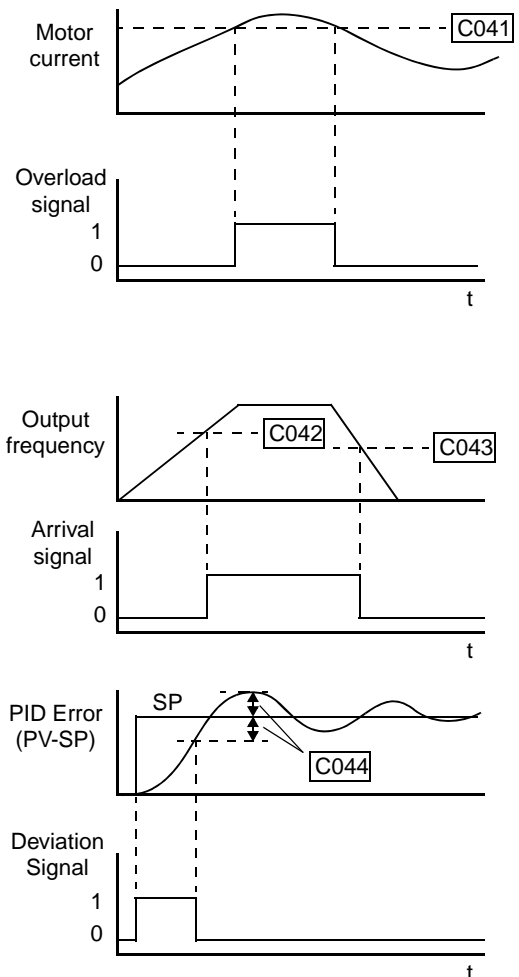

Configuring Drive Parameters

Func. Code	Name/Description	Keypad		Range and Settings	Defaults			Run Mode Edit Lo Hi
		SRW	OPE		FEF2 FE2 (EU)	FUF2 FU2 (USA)	FF2 F2 (Jpn)	
C038	Low current indication output mode select	ON	00	Output during acceleration/deceleration and constant speed operation	01	01	01	x ✓
		CRT	01	Output only during constant speed				
C039	Low current indication detection level			0.0 to 1.80 x rated inverter current	Rated current x 1.0			x ✓
	Low current threshold, used for intelligent output [LOC]							x ✓
C040	Overload signal output mode	ON	00	During accel / decel / constant speed	01	01	01	x ✓
	Choose when the overload signal is enabled	CRT	01	During constant speed only				
C041	Overload level setting 1			0.00 x rated current to 1.80 x rated current (A)	Rated current for inverter			x ✓
C042	Frequency arrival setting for acceleration			0.00 to 99.99, 100.0 to 400.0 (Hz)	0.00	0.00	0.00	x ✓
	Sets the frequency arrival setting threshold for the output frequency during acceleration							
C043	Arrival frequency setting for deceleration			0.00 to 99.99, 100.0 to 400.0 (Hz)	0.00	0.00	0.00	x ✓
	Sets the frequency arrival setting threshold for the output frequency during deceleration							
C044	PID deviation level setting			0.0 to 100.0 (%)	3.0	3.0	3.0	x ✓
	Sets the PID loop error threshold SP - PV (absolute value) to trigger intelligent output [OD]							
C045	Frequency arrival setting for acceleration (2)			0.0 to 99.99, 100.0 to 400.0 (Hz)	0.00	0.00	0.00	x ✓
C046	Frequency arrival setting for deceleration (2)			0.0 to 99.99, 100.0 to 400.0 (Hz)	0.00	0.00	0.00	x ✓
C052	Maximum PID feedback (PV) data			0.0 to 100.0 (%)	0.00	0.00	0.00	x ✓
C053	Minimum PID feedback (PV) data			0.0 to 100.0 (%)	100.0	100.0	100.0	x ✓
C055	Over-torque (forward-driving) level setting			0. to 180. (%)	100.	100.	100.	x ✓
	Threshold for intelligent output terminal [OTQ], quadrant I							
C056	Over-torque (reverse regenerating) level setting			0. to 180. (%)	100.	100.	100.	x ✓
	Threshold for intelligent output terminal [OTQ], quadrant II							
C057	Over-torque (reverse driving) level setting			0. to 180. (%)	100.	100.	100.	x ✓
	Threshold for intelligent output terminal [OTQ], quadrant III							
C058	Over-torque (forward regenerating) level setting			0. to 180. (%)	100.	100.	100.	x ✓
	Threshold for intelligent output terminal [OTQ], quadrant IV							
C061	Electronic thermal warning level setting			0. to 100. (%)	80.	80.	80.	x ✓
	Sets the threshold for intelligent output [THM]							
C062	Alarm code output	OFF	00	Disable	00	00	00	x ✓
	Allows binary alarm codes to be output to intelligent terminals	3BIT	01	Enable – 3-bit code				
		4BIT	02	Enable – 4-bit code				
C063	Zero speed detection level			0.00 to 99.99 / 100.0 (Hz)	0.00	0.00	0.00	x ✓
C064	Heatsink overheat warning level			0. to 200.0 (°C)	120	120	120	x ✓
	Alarm temperature threshold for heatsink in inverter							

Serial Communications

The following table configures the communications port of the SJ7002 inverter. You can have up to thirty-two devices on the serial communications network. The inverters are slaves and the computer or digital operator is the master. Thus, all inverters on the serial connection must use the same baud rate, data length, parity, and stop bits. However, each device on the serial network must have a unique node address. See [“Serial Communications” on page B-1](#) for more information.

Func. Code	Name/Description	Keypad		Range and Settings	Defaults			Run Mode Edit Lo Hi
		SRW	OPE		xFE2 (EU)	xFU2 (USA)	xFF2 (Jpn)	
C071	Communication speed selection	TEST	02	Test	04	04	04	X ✓
		2400bps	03	2400 (bps)				
		4800bps	04	4800 (bps)				
		9600bps	05	9600 (bps)				
		19200bps	06	19200 (bps)				
C072	Node allocation			1. to 32. (node)	1.	1.	1.	X ✓
	Set the address of the inverter on the network							
C073	Communication data length selection	7BIT	07	7-bit data	07	07	07	X ✓
		8BIT	08	8-bit data				
C074	Communication parity selection	NO	00	No parity	00	00	00	X ✓
		EVN	01	Even parity				
		ODD	02	Odd parity				
C075	Communication stop bit selection	1BIT	01	1 Stop bit	1	1	1	X ✓
		2BIT	02	2 Stop bits				
C076	Action upon communication error selection	TRP	00	Trip	02	02	02	X ✓
		DSTP	01	Trip after deceleration and stop				
		NEG	02	No action (ignore errors)				
		FRS	03	Free-run stop				
		DTP	04	Decelerate and stop				
C077	Communication timeout before trip			0.00 to 99.99 (seconds)	0.00	0.00	0.00	X ✓
C078	Communication wait time			0.0 to 1000 (milliseconds)	0.	0.	0.	X ✓
	Time the inverter waits after receiving a message before it transmits							
C079	Communication protocol select	ASCII	00	ASCII	00	00	00	X ✓
		Modbus	01	ModBus RTU				

Analog Signal Calibration Settings

The functions in the following table configure the signals for the analog output terminals. Note that these settings do not change the current/voltage or sink/source characteristics – only the zero and span (scaling) of the signals.



NOTE: See additional settings for analog calibration: Parameter B080 [AM] Terminal Analog Meter Adjustment (gain), parameter B081 [FM] Terminal Analog Meter Adjustment (gain).

Func. Code	Name/Description	Range and Settings	Defaults			Run Mode Edit Lo Hi
			FEF2 FE2 (EU)	FUF2 FU2 (USA)	FF2 F2 (Jpn)	
C081	[O] input span calibration	0. to 9999., 1000 to 6553 (10000 to 65530)	Factory-calibrated			✓ ✓
C082	[OI] input span calibration	0. to 9999., 1000 to 6553 (10000 to 65530)	Factory-calibrated			✓ ✓
C083	[O2] input span calibration	0. to 9999., 1000 to 6553 (10000 to 65530)	Factory-calibrated			✓ ✓
C085	Thermistor input tuning (gain)	0.0 to 999.9., 1000	105.0	105.0	105.0	✓ ✓
C121	[O] input zero calibration	0. to 9999., 1000 to 6553 (10000 to 65530)	Factory-calibrated			✓ ✓
C122	[OI] input zero calibration	0. to 9999., 1000 to 6553 (10000 to 65530)	Factory-calibrated			✓ ✓
C123	[O2] input zero calibration	0. to 9999., 1000 to 6553 (10000 to 65530)	Factory-calibrated			✓ ✓



NOTE: Settings C081, C082, C083, C121, C122, C123 are factory-calibrated for each inverter. Do not change these settings unless absolutely necessary. Note that if you restore factory defaults for all parameters, these settings will not change.

Miscellaneous Functions

The following table contains miscellaneous functions not in other function groups.

Func. Code	Name/Description	Keypad		Range and Settings	Defaults			Run Mode Edit Lo Hi
		SRW	OPE		FEF2 FE2 (EU)	FUF2 FU2 (USA)	FF2 F2 (Jpn)	
C091	Debug mode enable	MD0	00	No display	00	00	00	✗ ✗
		MD1	01	Display				
C101	Up/Down memory mode selection	NO-STR	00	Clear last frequency (return to default frequency F001)	00	00	00	✗ ✓
	Controls speed setpoint for the inverter after power cycle	STR	01	Keep last frequency adjusted by UP/DWN				

C102/C103: Reset Mode / Restart Mode – The reset mode selection, set via parameter C102, determines how the inverter responds to the [RS] intelligent input signal or keypad Stop/Reset key in a trip condition. The options allow you to cancel the trip on either the OFF-to-ON or ON-to-OFF transition of [RS], and if desired, stop the inverter if it is in Run Mode. A trip event causes the inverter output to the motor to turn OFF immediately. If in Run Mode when the trip

occurred, the inverter and motor will enter free-run stop (coasting) operation. In some applications, the motor and load will still be coasting when the inverter returns to normal Run Mode operation. For that situation, you can configure the inverter output (C103=00) to resume operation from 0 Hz and accelerate normally. Or, you can configure the inverter (C103=01) to resume operation from the current speed of the motor (*frequency matching*)—often used in applications such as HVAC.

Func. Code	Name/Description	Keypad		Range and Settings	Defaults			Run Mode Edit Lo Hi
		SRW	OPE		xFE2 (EU)	xFU2 (USA)	xFF2 (Jpn)	
C102	Reset mode selection	ON	00	Cancel trip state, stop inverter output, reset CPU; clear position counter at ON transition	00	00	00	✓ ✓
	Determines response to Reset input [RST]	OFF	01	Cancel trip state, stop inverter output, reset CPU; clear position counter at OFF transition				
		TRP	02	Cancel trip state and clear position counter; no effect if a trip does not exist				
		EXT	03	Cancel trip state but does not clear position counter; no effect if a trip does not exist				
C103	Restart mode after reset	ZST	00	Restart at 0 Hz	00	00	00	✗ ✓
		fST	01	Resume operation after frequency matching				
		FIX	02	Restart with active matching frequency				
C105	FM gain adjustment			50. to 200. (%)	100.	100.	100.	✗ ✓
C106	AM gain adjustment			50. to 200. (%)	100.	100.	100.	✗ ✓
C107	AMI gain adjustment			50. to 200. (%)	100.	100.	100.	✓ ✓
C109	AM bias adjustment			0. to 100. (%)	0.	0.	0.	✓ ✓
C110	AMI bias adjustment			0. to 100. (%)	20.	20.	20.	✓ ✓
C111	Overload setting (2)			0.00 x rated current to 1.80 x rated current (A)	Rated current for inverter			✗ ✓

Configuring Drive Parameters

Output Terminal Signal Functions

Func. Code	Name/Description	Keypad		Range and Settings	Defaults			Run Mode Edit Lo Hi
		SRW	OPE		FEF2 FE2 (EU)	FUF2 FU2 (USA)	FF2 F2 (Jpn)	
C130	Terminal [11] ON-delay time	—	—	0.0 to 100.0 (seconds)	0.0	0.0	0.0	✗ ✓
C131	Terminal [11] OFF-delay time	—	—	0.0 to 100.0 (seconds)	0.0	0.0	0.0	✗ ✓
C132	Terminal [12] ON-delay time	—	—	0.0 to 100.0 (seconds)	0.0	0.0	0.0	✗ ✓
C133	Terminal [12] OFF-delay time	—	—	0.0 to 100.0 (seconds)	0.0	0.0	0.0	✗ ✓
C134	Terminal [13] ON-delay time	—	—	0.0 to 100.0 (seconds)	0.0	0.0	0.0	✗ ✓
C135	Terminal [13] OFF-delay time	—	—	0.0 to 100.0 (seconds)	0.0	0.0	0.0	✗ ✓
C136	Terminal [14] ON-delay time	—	—	0.0 to 100.0 (seconds)	0.0	0.0	0.0	✗ ✓
C137	Terminal [14] OFF-delay time	—	—	0.0 to 100.0 (seconds)	0.0	0.0	0.0	✗ ✓
C138	Terminal [15] ON-delay time	—	—	0.0 to 100.0 (seconds)	0.0	0.0	0.0	✗ ✓

Func. Code	Name/Description	Keypad		Range and Settings	Defaults			Run Mode Edit Lo Hi
		SRW	OPE		FEF2 FE2 (EU)	FUF2 FU2 (USA)	FF2 F2 (Jpn)	
C139	Terminal [15] OFF-delay time	—	—	0.0 to 100.0 (seconds)	0.0	0.0	0.0	✕ ✓
C140	Relay output ON-delay time	—	—	0.0 to 100.0 (seconds)	0.0	0.0	0.0	✕ ✓
C141	Relay output OFF-delay time	—	—	0.0 to 100.0 (seconds)	0.0	0.0	0.0	✕ ✓
C142	Logic output 1 function A	—	—	All programmable output functions available (except LOG1 to LOG6)	00 (output frequency)			✕ ✓
C143	Logic output 1 function B	—	—					✕ ✓
C144	Logic output 1 operator	AND	00	AND	00	00	00	✕ ✓
		OR	01	OR				✕ ✓
		XOR	02	XOR (exclusive OR)				✕ ✓
C145	Logic output 2 function A	—	—	All programmable output functions available (except LOG1 to LOG6)	00 (output frequency)			✕ ✓
C146	Logic output 2 function B	—	—					✕ ✓
C147	Logic output 2 operator	AND	00	AND	00	00	00	✕ ✓
		OR	01	OR				✕ ✓
		XOR	02	XOR (exclusive OR)				✕ ✓
C148	Logic output 3 function A	—	—	All programmable output functions available (except LOG1 to LOG6)	00 (output frequency)			✕ ✓
C149	Logic output 3 function B	—	—					✕ ✓
C150	Logic output 3 operator	AND	00	AND	00	00	00	✕ ✓
		OR	01	OR				✕ ✓
		XOR	02	XOR (exclusive OR)				✕ ✓
C151	Logic output 4 function A	—	—	All programmable output functions available (except LOG1 to LOG6)	00 (output frequency)			✕ ✓
C152	Logic output 4 function B	—	—					✕ ✓
C153	Logic output 4 operator	AND	00	AND	00	00	00	✕ ✓
		OR	01	OR				✕ ✓
		XOR	02	XOR (exclusive OR)				✕ ✓
C154	Logic output 5 function A	—	—	All programmable output functions available (except LOG1 to LOG6)	00 (output frequency)			✕ ✓
C155	Logic output 5 function B	—	—					✕ ✓
C156	Logic output 5 operator	AND	00	AND	00	00	00	✕ ✓
		OR	01	OR				✕ ✓
		XOR	02	XOR (exclusive OR)				✕ ✓
C157	Logic output 6 function A	—	—	All programmable output functions available (except LOG1 to LOG6)	00 (output frequency)			✕ ✓
C158	Logic output 6 function B	—	—					✕ ✓
C159	Logic output 6 operator	AND	00	AND	00	00	00	✕ ✓
		OR	01	OR				✕ ✓
		XOR	02	XOR (exclusive OR)				✕ ✓

Input Signal Terminal Functions

Func. Code	Name/ Description	Range and Settings	Defaults			Run Mode Edit Lo Hi
			FEF2 FE2 (EU)	FUF2 FU2 (USA)	FF2 F2 (Jpn)	
C160	Terminal [1] input response time	0. to 200. (x 2 ms)	0.0	0.0	0.0	✗ ✓
C161	Terminal [2] input response time	0. to 200. (x 2 ms)	0.0	0.0	0.0	✗ ✓
C162	Terminal [3] input response time	0. to 200. (x 2 ms)	0.0	0.0	0.0	✗ ✓
C163	Terminal [4] input response time	0. to 200. (x 2 ms)	0.0	0.0	0.0	✗ ✓
C164	Terminal [5] input response time	0. to 200. (x 2 ms)	0.0	0.0	0.0	✗ ✓
C165	Terminal [6] input response time	0. to 200. (x 2 ms)	0.0	0.0	0.0	✗ ✓
C166	Terminal [7] input response time	0. to 200. (x 2 ms)	0.0	0.0	0.0	✗ ✓
C167	Terminal [8] input response time	0. to 200. (x 2 ms)	0.0	0.0	0.0	✗ ✓
C168	Terminal [FW] input response time	0. to 200. (x 2 ms)	0.0	0.0	0.0	✗ ✓
C169	Multistage speed/position determination time	0. to 200. (x 10 ms)	0.0	0.0	0.0	✗ ✓

“H” Group: Motor Constants Functions

Introduction

The “H” Group parameters configure the inverter for the motor characteristics. You must manually set H003 and H004 values to match the motor. Most of the remaining parameters are related to vector control, and are in use only when function A044 is set for one of the vector control modes as shown in the diagram. The procedure in [“Auto-tuning of Motor Constants” on page 4-71](#) automatically sets all the parameters related to vector control. If you configure the inverter to use vector control, we highly recommend letting the auto-tuning procedure derive the values for you. If you want to reset the parameters to the factory default settings, use the procedure in [“Restoring Factory Default Settings” on page 6-16](#).

Inverter Torque Control Algorithms

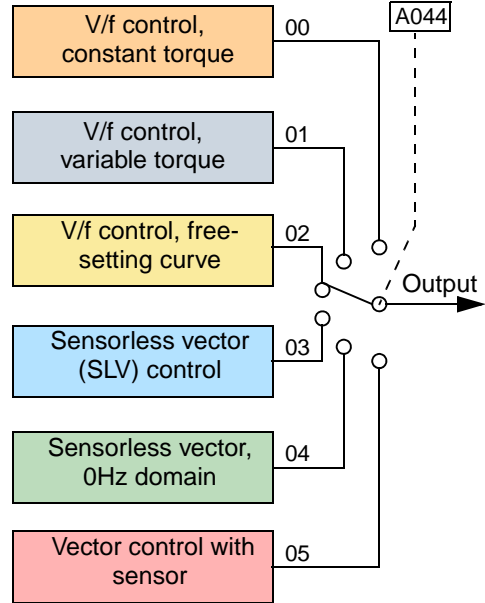

NOTE: The auto-tuning procedure and related warning messages are in [“Auto-tuning of Motor Constants” on page 4-71](#). Please read these before trying to auto-tune the motor parameters.

Func. Code	Name/Description	Keypad		Range and Settings	Defaults			Run Mode Edit Lo Hi
		SRW	OPE		FEF2 (EU)	FUF2 (USA)	FF2 (Jpn)	
H001	Auto-tuning Setting	NOR	00	Auto-tuning OFF	00	00	00	X X
		HRT	01	Auto-tune (measure motor resistance and inductance, without rotating)				
		AUT	02	Auto-tune (rotate motor)				
H002	Motor data selection, 1st motor	NOR	00	Standard motor data	00	00	00	X X
		AUT	01	Auto-tuning data				
		ON-AUT	02	Adaptive tuning data				
H202	Motor data selection, 2nd motor	NOR	00	Standard motor data	00	00	00	X X
		AUT	01	Auto-tuning data				
		ON-AUT	02	Adaptive tuning data				
H003	Motor capacity, 1st motor			0.20 to 400. (kW)	Factory set			X X
H203	Motor capacity, 2nd motor			0.20 to 400 (kW)	Factory set			X X
H004	Motor poles setting, 1st motor			2, 4, 6, 8, 10 (poles)	4	4	4	X X
H204	Motor poles setting, 2nd motor			2, 4, 6, 8, 10 (poles)	4	4	4	X X

Func. Code	Name/ Description	Keypad		Range and Settings	Defaults			Run Mode Edit Lo Hi
		SRW	OPE		FEF2 FE2 (EU)	FUF2 FU2 (USA)	FF2 F2 (Jpn)	
H005	Motor speed constant, 1st motor			0.001 to 9.999, 10.00 to 80.00 (10.000 to 80.000)	1.590	1.590	1.590	✓✓
	Motor proportional gain constant, factory set							
H205	Motor speed constant, 2nd motor			0.001 to 9.999, 10.00 to 80.00 (10.000 to 80.000)	1.590	1.590	1.590	✓✓
	Motor proportional gain constant, factory set							
H006	Motor stabilization constant, 1st motor			0. to 255. (factory set)	100.	100.	100.	✓✓
H206	Motor stabilization constant, 2nd motor			0. to 255. (factory set)	100.	100.	100.	✓✓
H306	Motor stabilization constant, 3rd motor			0. to 255. (factory set)	100.	100.	100.	✓✓
H020	Motor constant R1, 1st motor			0.001 to 9.999, 10.00 to 65.53 (Ohms)	According to inverter rating			✗✗
H220	Motor constant R1, 2nd motor			0.001 to 9.999, 10.00 to 65.53 (Ohms)				✗✗
H021	Motor constant R2, 1st motor			0.001 to 9.999, 10.00 to 65.53 (Ohms)				✗✗
H221	Motor constant R2, 2nd motor			0.001 to 9.999, 10.00 to 65.53 (Ohms)				✗✗
H022	Motor constant L, 1st motor			0.01 to 99.99, 100.0 - 655.3 (mH)	According to inverter rating			✗✗
H222	Motor constant L, 2nd motor			0.01 to 99.99, 100.0 - 655.3 (mH)				✗✗
H023	Motor constant I ₀ , 1st motor			0.01 to 99.99, 100.0 - 655.3 (A)				✗✗
H223	Motor constant I ₀ , 2nd motor			0.01 to 99.99, 100.0 - 655.3 (A)				✗✗
H024	Motor Constant J, 1st motor			0.001 to 9.999, 10.00 to 99.99, 100.0 to 999.9, 1000 to 9999. (ratio, unit-less)	According to inverter rating			✗✗
H224	Motor constant J, 2nd motor			0.001 to 9.999, 10.00 to 99.99, 100.0 to 999.9, 1000 to 9999. (ratio, unit-less)				✗✗
H030	Auto-tuned motor constant R1, 1st motor			0.001 to 9.999, 10.00 to 65.53 (Ohms)	According to inverter rating			✗✗
H230	Auto-tuned motor constant R1, 2nd motor			0.001 to 9.999, 10.00 to 65.53 (Ohms)				✗✗
H031	Auto-tuned motor constant R2, 1st motor			0.001 to 9.999, 10.00 to 65.53 (Ohms)	According to inverter rating			✗✗
H231	Auto-tuned motor constant R2, 2nd motor			0.001 to 9.999, 10.00 to 65.53 (Ohms)				✗✗
H032	Auto-tuned motor constant L, 1st motor			0.01 to 99.99, 100.0 to 655.3 (mH)	According to inverter rating			✗✗
H232	Auto-tuned motor constant L, 2nd motor			0.01 to 99.99, 100.0 to 655.3 (mH)				✗✗
H033	Auto-tuned motor constant I ₀ , 1st motor			0.01 to 99.99, 100.0 to 655.3 (mH)	According to inverter rating			✗✗
H233	Auto-tuned motor constant I ₀ , 2nd motor			0.01 to 99.99, 100.0 to 655.3 (mH)				✗✗
H034	Auto-tuned motor constant J, 1st motor			0.001 to 9.999, 10.00 to 99.99, 100.0 to 999.9, 1000 to 9999. (ratio, unit-less)	According to inverter rating			✗✗
H234	Auto constant J, 2nd motor			0.001 to 9.999, 10.00 to 99.99, 100.0 to 999.9, 1000 to 9999. (ratio, unit-less)				✗✗
H050	PI proportional gain for 1st motor			0.0 to 999.9, 1000.	100.0	100.0	100.0	✓✓
H250	PI proportional gain for 2nd motor			0.0 to 999.9, 1000.	100.0	100.0	100.0	✓✓
H051	PI integral gain for 1st motor			0.0 to 999.9, 1000.	100.0	100.0	100.0	✓✓
H251	PI integral gain for 2nd motor			0.0 to 999.9, 1000.	100.0	100.0	100.0	✓✓
H052	P proportional gain setting for 1st motor			0.01 to 10.00	1.00	1.00	1.00	✓✓
H252	P proportional gain setting for 2nd motor			0.01 to 10.00	1.00	1.00	1.00	✓✓
H060	0Hz SLV limit for 1st motor			0.0 to 100.0	100.	100.	100.	✓✓

Func. Code	Name/Description	Keypad		Range and Settings	Defaults			Run Mode Edit Lo Hi
		SRW	OPE		FEF2 FE2 (EU)	FUF2 FU2 (USA)	FF2 F2 (Jpn)	
H260	0Hz SLV limit for 2nd motor			0.0 to 100.0	100.	100.	100.	✓✓
H061	0Hz SLV starting boost current for 1st motor			0. to 50. (%)	100.	100.	100.	✓✓
H261	0Hz SLV starting boost current for 2nd motor			0. to 50. (%)	100.	100.	100.	✓✓
H070	Terminal selection PI proportional gain setting			0.0 to 999.9, 1000	100.0	100.0	100.0	✓✓
H071	Terminal selection PI integral gain setting			0.00 to 999.9, 1000.	100.0	100.0	100.0	✓✓
H072	Terminal selection P proportional gain setting			0.00 to 10.00	1.00	1.00	1.00	✓✓
H073	Gain switching time			0. to 999. (milliseconds)	100.	100.	100.	✓✓

“P” Group: Expansion Card Functions

The two (optional) expansion cards for the SJ700 have associated configuration data. The following table defines the functions and their value ranges. Please refer to the expansion card manual for more details.

Func. Code	Name/ Description	Keypad		Range and Settings	Defaults			Run Mode Edit Lo Hi
		SRW	OPE		FEF2 FE2 (EU)	FUF2 FU2 (USA)	FF2 F2 (Jpn)	
P001	Operation mode on expansion card 1 error	TRP	00	Trip (stop motor)	00	00	00	X ✓
		RUN	01	Continuous operation				
P002	Operation mode on expansion card 2 error	TRP	00	Trip (stop motor)	00	00	00	X ✓
		RUN	01	Continuous operation				
P011	Encoder pulse-per-revolution (PPR) setting			128 to 65000 (pulses per revolution)	1024	1024	1024	X X
P012	Control pulse setting	ASR	00	Automatic Speed Regulation (ASR) mode	00	00	00	X X
		APR	01	Automatic Position Regulation (APR) mode				X X
		APR2	02	Absolute Position Control				X X
		HAPR	03	High-resolution Absolute Position Control				X X
P013	Pulse input mode setting	MD0	00	Quadrature mode	00	00	00	X X
		MD1	01	Count and direction				
		MD2	02	Separate forward and reverse pulse trains				
P014	Home search stop position setting			0. to 4095. (pulses)	0.	0.	0.	X ✓
P015	Home search speed setting			Start frequency to maximum frequency (up to 120.0) (Hz)	5.00	5.00	5.00	X ✓
P016	Home search direction setting	FW	00	Forward	00	00	00	X X
		RV	01	Reverse				X X
P017	Home search completion range setting			0. to 9999., 1000 (10,000) (pulses)	5	5	5	X ✓
P018	Home search completion delay time setting			0.00 to 9.99 (seconds)	0.00	0.00	0.00	X ✓
P019	Electronic gear set position selection	FB	00	Position feedback side	00	00	00	X ✓
		REF	01	Position command side				X ✓
P020	Electronic gear ratio numerator setting			0. to 9999.	1.	1.	1.	X ✓
P021	Electronic gear ratio denominator setting			1 to 9999	1.	1.	1.	X ✓
P022	Feed-forward gain setting			0.00 to 99.99, 100.0 to 655.3	0.00	0.00	0.00	X ✓
P023	Position loop gain setting			0.00 to 99.99, 100.0	0.50	0.50	0.50	X ✓
P024	Position bias setting			-204 (-2048) / -999. to 2048	0.	0.	0.	X ✓
P025	Temperature compensation thermistor enable	OFF	00	No compensation	00	00	00	X ✓
	Allows for motor-mounted thermistor to calibrate output to motor temperature	ON	01	With compensation				
P026	Over-speed error detection level setting			0.0 to 150.0 (%)	135.0	135.0	135.0	X ✓
P027	Speed deviation error detection level setting			0.00 to 99.99, 100.0 to 120.0 (Hz)	7.50	7.50	7.50	X ✓
P028	Motor gear ratio numerator setting			0. to 9999.	1.	1.	1.	X ✓

Func. Code	Name/Description	Keypad		Range and Settings	Defaults			Run Mode Edit Lo Hi
		SRW	OPE		FEF2 FE2 (EU)	FUF2 FU2 (USA)	FF2 F2 (Jpn)	
P029	Motor gear ratio denominator setting			1 to 9999	1.	1.	1.	✗ ✓
P031	Accel/decel time input selection	REM	00	Inverter	00	00	00	✗ ✗
		OP1	01	Expansion card 1				
		OP2	02	Expansion card 2				
P032	Positioning command input selection	REM	00	Inverter	00	00	00	✗ ✓
		OP1	01	Expansion card 1				
		OP2	02	Expansion card 2				
P033	Torque command input selection	0	00	[O] terminal	00	00	00	✗ ✗
		OI	01	[OI] terminal				
		O2	02	[O2] terminal				
		REM	03	Inverter keypad (P034)				
P034	Torque command setting			0. to 180. (%)	0.	0.	0.	✗ ✗
P035	Torque command polarity select	NOR	00	Indicated by signal polarity at [O2] terminal	00	00	00	✗ ✗
		DIR	01	Depends on motor direction				
P036	Torque bias mode	NO	00	Disable	00	00	00	✗ ✗
		DIR	01	Inverter keypad (P037)				
		NOR	02	[O2] terminal input				
P037	Torque bias value			0. to 180. (%)	0.	0.	0.	✗ ✗
P038	Torque bias polarity	NOR	00	Indicated by polarity	00	00	00	✗ ✓
		DIR	01	Depends on motor direction				
P039	Forward speed limit for torque-control mode			0.00 to maximum frequency (Hz)	0.00	0.00	0.00	✗ ✗
P040	Reverse speed limit for torque-control mode			0.00 to maximum frequency (Hz)	0.00	0.00	0.00	✗ ✗
P044	DeviceNet comm watchdog timer			0.00 to 99.99 (seconds)	1.00	1.00	1.00	✗ ✗
P045	Inverter action on DeviceNet comm error	TRP	00	Trip	01	01	01	✗ ✗
		FTP	01	Decelerate and trip				
		NO	02	Hold last speed				
		FRS	03	Free run stop				
		DEC	04	Decelerate and stop				
P046	DeviceNet polled I/O: Output instance number			20, 21, 100	21	21	21	✗ ✗
P047	DeviceNet polled I/O: Input instance number			70, 71, 101	71	71	71	✗ ✗
P048	Inverter action on DeviceNet idle mode	TRP	00	Trip	01	01	01	✗ ✗
		FTP	01	Decelerate and trip				
		NO	02	Hold last speed				
		FRS	03	Free run stop				
		DEC	04	Decelerate and stop				
P049	DeviceNet motor poles setting for RPM	poles	poles	00 to 38 (even numbers only)	0	0	0	✗ ✗

Func. Code	Name/ Description	Keypad		Range and Settings	Defaults			Run Mode Edit Lo Hi
		SRW	OPE		FEF2 FE2 (EU)	FUF2 FU2 (USA)	FF2 F2 (Jpn)	
P055	Pulse train frequency scale			1.0 to 50.0 (kHz)	25.0	25.0	25.0	✗ ✓
P056	Pulse train frequency filter time constant			0.01 to 2.00 (seconds)	0.10	0.10	0.10	✗ ✓
P057	Pulse train frequency bias			-100. to 100. (%)	0.	0.	0.	✗ ✓
P058	Pulse train frequency limit			0. to 100. (%)	100.	100.	100.	✗ ✓
P060 to P067	Multi-stage position setting 0 to Multi-stage position setting 7			Reverse side to forward side (upper four digits including sign “-”)	0	0	0	✓ ✓
P068	Zero-return mode selection	LOW	00	Low speed	00	00	00	✓ ✓
		Hi1	01	High speed				
		Hi2	02	High speed 2				
P069	Zero return direction selection	FW	00	Forward	00	00	00	✓ ✓
		RW	01	Reverse				
P070	Low speed zero return frequency			0.00 to 10.00 (Hz)	0.00	0.00	0.00	✓ ✓
P071	High speed zero return frequency			0.00 to 99.99 / 100.0 to maximum frequency setting, 1st motor (Hz)	0.00	0.00	0.00	✓ ✓
P072	Forward position range			0 to 268435455 (when P012 = 02), 0 to 1073741823 (when P013 = 03) (upper four digits)	268435455			✓ ✓
P073	Reverse position range			-268435455 to 0 (when P012 = 02), 1073741823 to 0 (when P013 = 03) (upper four digits)	-268435455			✓ ✓
P074	Teaching selection	X00	00	X00	00	00	00	✓ ✓
		X01	01	X01				
		X02	02	X02				
		X03	03	X03				
		X04	04	X04				
		X05	05	X05				
		X06	06	X06				
X07	07	X07						
P100 to P131	Easy sequence user parameters U(00) to U(31)			0. to 9999., 1000 to 6553 (10000 to 65535)	0.	0.	0.	✓ ✓

Configuring Drive Parameters



NOTE: Parameters P044 to P049 are available only in inverters with manufacturing code x8K xxxxxx xxxxx or later. The manufacturing code is printed on the product specifications labels, located on the front and side of the inverter housing.

Absolute Position Control Mode

To use the absolute position control mode, set A044 V/F characteristic curve setting (1st motor) equal to "02" (V2) and set P012 Control Pulse Setting equal to "02" APR – Automatic Position Control Mode.

- If P012 = 03 (high-resolution absolute position control, the inverter quadruples the number of pulses used for positioning. In this case multiply the multistage position settings and position ranges by four.
- Position settings can be sequenced in up to eight stages in combination with control pulse settings. You can select zero-return mode from one low-speed and two high-speed modes. (The home search function cannot be used during a zero-return.)
- The teaching function allows you to set (store) position settings while actually running the machine (motor is turning).
- If intelligent terminal [SPD] Speed/position Control Select (option code 73) is assigned, you can switch between speed control and position control.
- Only the four high-order digits of data are displayed when the data (position setting) to be displayed consists of a large number of digits.

In Absolute Position Control Mode, the inverter runs the motor until the machine reaches the target position according to the following settings, and then set the machine into the position servo-lock state (until the Stop Command occurs):

1. Position setting
2. Speed setting (output frequency)
3. Acceleration and deceleration time

In absolute position control mode, the frequency and accel/decel settings selected at absolute position control are applied. If the position setting value is small, the inverter may decelerate the motor for positioning before its speed reached the set speed setting. In absolute position control mode, the direction of the operations command (forward or reverse) is ignored. The operation command simply functions as a signal to run or stop the motor. Motor direction is determined by the algebraic sign of the difference between the current position and the target position.

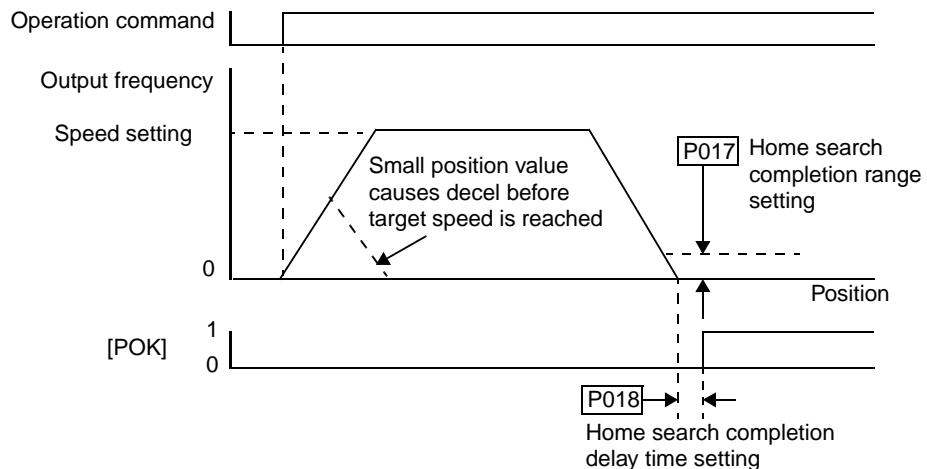

If zero return operation as described below is not performed, the motor position detected at powerup is assumed to be at the origin (position data = 0). When the operation command is turned ON with zero specified as the position setting, positioning is completed without running the motor.

Set C102 Reset Mode Selection = 03 so that the inverter only resets a trip condition (does not turn OFF the motor output). Otherwise, the current position counter is cleared when the inverter reset terminal turns ON. Be sure to set C102 = 03 if you intend to use the value of the current position counter for operation after recovering the inverter from a trip by turning ON the reset terminal (reset key).

If intelligent terminal [PCLR] is assigned, when it is ON the current position counter is cleared and the position deviation counter is also cleared.

When the inverter is in Absolute Position Control Mode, some functions are necessarily disabled:

- Intelligent terminal [ATR] is ignored (because torque control is disabled)
- Intelligent terminal [STAT] is ignored (because pulse train position control is disabled)
- Home search function is disabled

Teaching Function

The teaching function allows you to make the inverter run and stop the motor as desired and store current position data to a position command memory location that you select. Assign the [ORT] Orientation function (option code 45) to an intelligent input. The [ORT] terminal functions as the teaching input terminal when P012 Control Pulse Setting is set to 02 (Absolute Position Control) or 03 (High-resolution Absolute Position Control).

The teaching procedure is as follows:

1. Select the teaching position memory location by setting P074.
2. Move the work piece or machine to the desired location. Enter an operation command while the [ORT] terminal is in the ON state. The speed and accel/decel settings selected at the operation command input are applied.

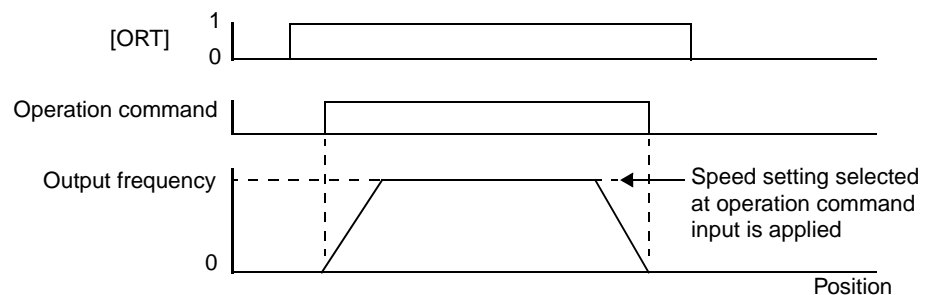

Teaching operation can be performed when power is input to the power supply terminals [R0] and [T0] of the inverter control circuit. The current position counter also operates when an external device moves the work piece. Therefore, the teaching operation can also be performed when the inverter does not operate (move) the machine.



NOTE: When teaching position data to an inverter that is not operating the machine, be sure to either disconnect input power terminals ([R], [S], and [T]) or disconnect the motor output terminals ([U], [V], and [W]). Otherwise, personal injury or damage to equipment may result.

3. Press the STR key on the digital operator when the target position is reached.
4. The current position data is stored to the memory area selected by parameter P074 teaching selection. (P074 value itself is not stored. After power OFF or reset, 00 is stored.)

"U" Group: User-selectable Menu Functions

The user-selectable menu functions allow you to configure (select) any twelve of the other functions in the inverter and place them together in a convenient list. This feature provides quick access for the most-used functions needed for your application. Each U Group function can serve as a pointer to any of the other parameters. You do *not* have to use the Store key to retain each association; just scroll to the desired standard parameter for each U Group function and leave it. The setting can point to a monitor-only parameter (such as D001), or point to editable parameters (such as A001). In the case of pointing to an editable functions, you use the Up/Down keys to change the value and the Store key to accept the change into memory—the same procedure as a normal parameter edit.

Func. Code	Name/Description	Range and Settings	Defaults			Run Mode Edit Lo Hi
			FEF2 FE2 (EU)	FUF2 FU2 (USA)	FF2 F2 (Jpn)	
U001	User function 1	"no" (disabled), or any of the functions D001 to P049	no	no	no	X ✓
U002	User function 2		no	no	no	X ✓
U003	User function 3		no	no	no	X ✓
U004	User function 4		no	no	no	X ✓
U005	User function 5		no	no	no	X ✓
U006	User function 6		no	no	no	X ✓
U007	User function 7		no	no	no	X ✓
U008	User function 8		no	no	no	X ✓
U009	User function 9		no	no	no	X ✓
U010	User function 10		no	no	no	X ✓
U011	User function 11		no	no	no	X ✓
U012	User function 12		no	no	no	X ✓



TIP: Function B037 selects which parameter groups are displayed. If you want to limit the displayed parameters to *only* the U Group functions, set B037=02.

Programming Error Codes

The SJ7002 inverter operator keypad displays a special code (begins with the **H** character) to indicate a programming error. Programming errors exist when one parameter conflicts with the meaningful range permitted by related parameter(s). Note that particular real-time frequency (speed) input levels can cause a conflict in some situations. After a conflict exists, the error code will appear on the display, or you can view it later with D090 in Monitor Mode. Also, the PGM LED on the display will flash ON/OFF when programming. These indications are automatically cleared when the parameter is corrected to the allowed range.

Programming Error Code	Parameter out of bounds		Boundary defined by..		
	Code	Description	<, >	Code	Description
H001 H201	A8061 / A261	Frequency upper limit setting; 1st, 2nd motor	>	A004 / A204 / A304	Maximum frequency; 1st, 2nd, 3rd motor
H002 H202	A062 / A262	Frequency lower limit setting; 1st, 2nd motor	>		
H004 H204 H304	A003 / A203 / A303	Base frequency setting; 1st, 2nd, 3rd motor (*1)	>		
H005 H205 H305	F001, A020 / A220 / A320	Output frequency setting, Multi-speed freq. setting; 1st, 2nd, 3rd motor (*2)	>		
H006 H206 H306	A021 to A035	Multi-speed freq. settings	>		
H009	P015	Home search speed setting	>		
H012 H212	A062 / A262	Frequency lower limit setting; 1st, 2nd motor	>	A061 / A261	Frequency upper limit setting; 1st, 2nd motor
H015 H215	F001, A020 / A220	Output frequency setting, Multi-speed freq. setting; 1st, 2nd motor	>		
H016 H216	A021 to A035	Multi-speed freq. settings	>		
H019	A061 / A261	Frequency upper limit setting; 1st, 2nd motor	<	P015	Home search speed setting
H021 H221			<	A062 / A262	Frequency lower limit setting; 1st, 2nd motor
H025 H225	F001, A020 / A220	Output frequency setting, Multi-speed freq. setting; 1st, 2nd motor (*2)	<		
H031 H231	A061 / A261	Frequency upper limit setting; 1st, 2nd motor	<	B082	Start frequency adjustment
H032 H232	A062 / A262	Frequency lower limit setting; 1st, 2nd motor	<		
H035 H235 H335	F001, A020 / A220 / A320	Output frequency setting, Multi-speed freq. setting; 1st, 2nd, 3rd motor	<		
H036	A021 to A035	Multi-speed freq. settings	<		
H037	A038	Jog frequency setting	<		

Programming Error Code	Parameter out of bounds		Boundary defined by...		
	Code	Description	<, >	Code	Description
U085 U285 U385	F001, A020 / A220 / A320	Output frequency setting, Multi-speed freq. setting; 1st, 2nd, 3rd motor	>f-x, <f+x	A063 ± A064 A065 ± A066 A067 ± A068	Jump (center) frequency ± jump (hysteresis) frequency width setting
U086	A021 to A035	Multi-speed freq. settings	>f-x, <f+x		(See note after table)

Programming Error Code	Parameter out of bounds		Boundary defined by...		
	Code	Description	<, >	Code	Description
U091 U291	A061 / A261	Frequency upper limit setting; 1st, 2nd motor	>	B112	Free-setting V/f frequency (7)
U092 U292	A062 / A262	Frequency lower limit setting; 1st, 2nd motor	>		
U095 U295	F001, A020 / A220	Output frequency setting, Multi-speed freq. setting; 1st, 2nd motor	>		
U096	A021 to A035	Multi-speed freq. settings	>		
U110	B100, B102, B104, B106, B108, B110	Free V/f frequency	>	B100	Free-setting V/f frequency (1)
	B102, B104, B106, B108, B110	Free V/f frequency	>		
	B100	Free V/f frequency	<	B102	Free-setting V/f frequency (2)
	B104, B106, B108, B110	Free V/f frequency	>		
	B100, B102	Free V/f frequency	<	B104	Free-setting V/f frequency (3)
	B106, B108, B110	Free V/f frequency	>		
	B100, B102, B104	Free V/f frequency	<	B106	Free-setting V/f frequency (4)
	B108, B110	Free V/f frequency	>		
	B100, B102, B104, B106	Free V/f frequency	<	B108	Free-setting V/f frequency (5)
	B110	Free V/f frequency	>		
B100, B102, B104, B106, B108	Free V/f frequency	<	B110	Free-setting V/f frequency (6)	
U120	B017, B019	Free-setting electronic thermal frequency	<	B015	Free-setting, electronic thermal frequency (1)
	B015	Free-setting electronic thermal frequency	>	B017	Free-setting, electronic thermal frequency (2)
	B019	Free-setting electronic thermal frequency	<		
	B015, B017	Free-setting electronic thermal frequency	>	B019	Free-setting, electronic thermal frequency (3)

- Note 1:** The base frequency is written when you store the parameter. If the new base frequency value is outside the permissible range, a motor burnout may result. Therefore, if the warning occurs, change the base frequency to an appropriate value.
- Note 2:** These parameters are checked even when the digital operator (option code 02) is not specified for the frequency source setting (A001).
- Note 3:** Set frequency (speed) values are not permitted to be inside the jump frequency ranges, if defined. When a frequency reference value from a real-time source (such as keypad potentiometer or analog input) are inside a jump frequency range, the actual speed is automatically forced to equal the lowest point of the jump range.



Operations and Monitoring



4

In This Chapter....	page
— Introduction	2
— Optional Controlled Decel and Alarm at Power Loss	4
— Connecting to PLCs and Other Devices	7
— Using Intelligent Input Terminals	13
— Using Intelligent Output Terminals	43
— Analog Input Operation	63
— Analog Output Operation	66
— Setting Motor Constants for Vector Control	69
— PID Loop Operation	75
— Configuring the Inverter for Multiple Motors	76

Introduction

The previous material in Chapter 3 gave a reference listing of all the programmable functions of the inverter. We suggest that you first scan through the listing of inverter functions to gain a general familiarity. This chapter will build on that knowledge in the following ways:

1. **Related functions** – Some parameters interact with or depend on the settings in other functions. This chapter lists “required settings” for a programmable function to serve as a cross-reference and an aid in showing how functions interact.
2. **Intelligent terminals** – Some functions rely on an input signal from control logic terminals or generate output signals in other cases.
3. **Electrical interfaces** – This chapter shows how to make connections between the inverter and other electrical devices.
4. **Auto-tuning** – The SJ7002 inverter has the ability to run a calibration procedure in which it takes measurements of the motor’s electrical characteristics. This chapter shows how to run the auto-tuning procedure to help the inverter run the motor more smoothly and efficiently.
5. **PID Loop Operation** – The SJ7002 has a built-in PID loop that calculates the optimal inverter output frequency to control an external process. This chapter shows the parameters and input/output terminals associated with PID loop operation.
6. **Multiple motors** – A single SJ7002 inverter may be used with two or more motors in some types of applications. This chapter shows the electrical connections and inverter parameters involved in multiple-motor applications.

The topics in this chapter can help you decide the features that are important to your application, and how to use them. The basic installation covered in Chapter 2 concluded with the powerup test and running the motor. Now, this chapter starts from that point and shows how to make the inverter part of a larger control or automation system.

Before continuing, please read the following Caution messages.

Cautions for Operating Procedures



CAUTION: The heat sink fins will have a high temperature. Be careful not to touch them. Otherwise, there is the danger of getting burned.



CAUTION: The operation of the inverter can be easily changed from low speed to high speed. Be sure check the capability and limitations of the motor and machine before operating the inverter. Otherwise, it may cause injury to personnel.



CAUTION: If you operate a motor at a frequency higher than the inverter standard default setting (50Hz/60Hz), be sure to check the motor and machine specifications with the respective manufacturer. Only operate the motor at elevated frequencies after getting their approval. Otherwise, there is the danger of equipment damage.

Warnings for Operating Procedures

Before continuing, please read the following Warning messages.



WARNING: Be sure to turn ON the input power supply only after closing the front case. While the inverter is energized, be sure not to open the front case. Otherwise, there is the danger of electric shock.



WARNING: Be sure not to operate electrical equipment with wet hands. Otherwise, there is the danger of electric shock.



WARNING: While the inverter is energized, be sure not to touch the inverter terminals even when the motor is stopped. Otherwise, there is the danger of electric shock.



WARNING: If the Retry Mode is selected, the motor may suddenly restart after a trip stop. Be sure to stop the inverter before approaching the machine (be sure to design the machine so that safety for personnel is secure even if it restarts.) Otherwise, it may cause injury to personnel.



WARNING: If the power supply is cut OFF for a short period of time, the inverter may restart operation after the power supply recovers if the Run command is active. If a restart may pose danger to personnel, so be sure to use a lock-out circuit so that it will not restart after power recovery. Otherwise, it may cause injury to personnel.



WARNING: The Stop Key is effective only when the Stop function is enabled. Be sure to enable the Stop Key separately from the emergency stop. Otherwise, it may cause injury to personnel.



WARNING: During a trip event, if the alarm reset is applied and the Run command is present, the inverter will automatically restart. Be sure to apply the alarm reset only after verifying the Run command is OFF. Otherwise, it may cause injury to personnel.



WARNING: Be sure not to touch the inside of the energized inverter or to put any conductive object into it. Otherwise, there is a danger of electric shock and/or fire.



WARNING: If power is turned ON when the Run command is already active, the motor will automatically start and injury may result. Before turning ON the power, confirm that the RUN command is not present.



WARNING: When the Stop key function is disabled, pressing the Stop key does not stop the inverter, nor will it reset a trip alarm.



WARNING: Be sure to provide a separate, hard-wired emergency stop switch when the application warrants it.

Optional Controlled Decel and Alarm at Power Loss

With the default SJ7002 inverter configuration, a sudden power loss will cause the inverter to shut down immediately. If running at the time, the motor and load will coast to a stop. And without power, the inverter's alarm output will not activate. This default performance may be fine for applications with loads such as fans and pumps. However, some loads may require controlled decelerations upon power loss, or you may want an alarm signal upon power loss. This section describes how to harness regenerative energy so that the motor/load actually powers the inverter long enough to control a final deceleration and power the alarm output.

The diagram below shows the default configuration. Chapter 2 covered wiring the power source to the inverter input and the inverter output to the motor. By default, the inverter's internal control circuit gets its power from two phases (R and T) from the input. The user-accessible 2-wire jumper (R-R0 and T-T0) connects input power to the control circuit.

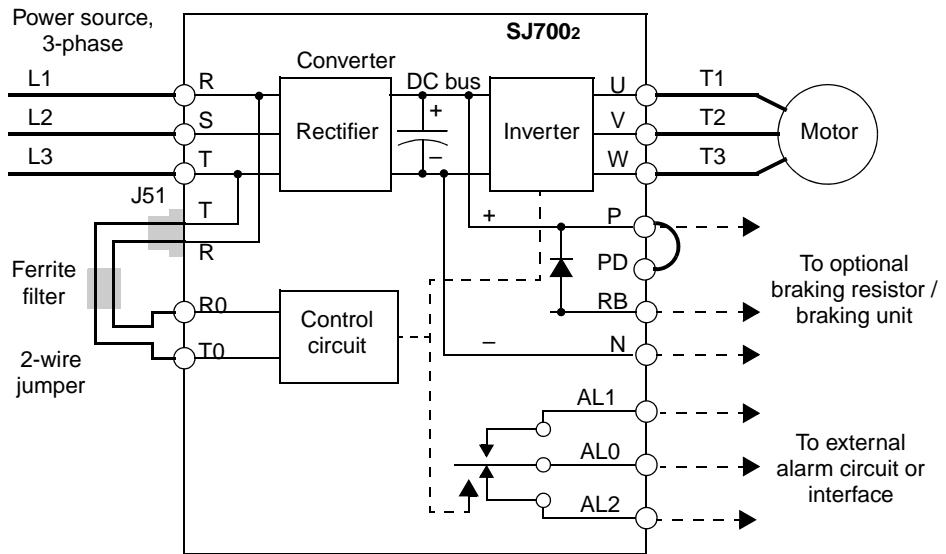

To provide power to the control circuit after input power loss, you must change the control circuit wiring as shown below (steps provided on following page).

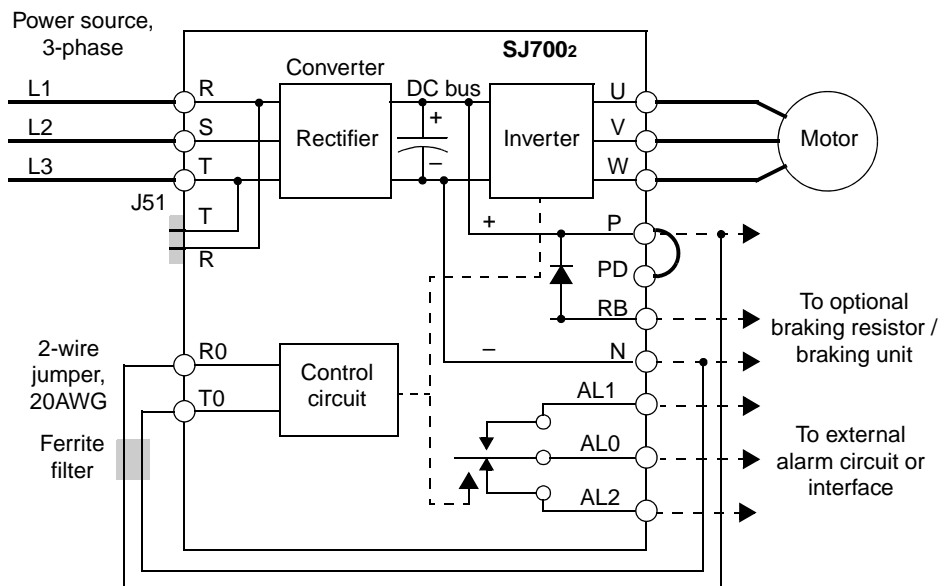

Follow the steps to implement the wiring change shown in the previous diagram.

1. Remove the 2-wire jumper J51 (terminals [R0] and [T0] to connector J51).
2. Procure several inches of multi-strand 20 AWG (0.5mm²) or slightly heavier wire.
3. Connect a wire to terminal [R0] that is long enough to connect to terminal [P] (do not connect to [P] yet).
4. Connect a wire to terminal [T0] that is long enough to connect to terminal [N] (do not connect to [N] yet).
5. Remove the ferrite filter from the original jumper wire and then slide it onto the new wires connecting to terminals [R0] and [T0]. (Be sure to save the original jumper in a safe place.)
6. Connect the wire from [R0] to [P], and connect the wire from [T0] to [N] as shown.

More information on power loss related alarm functions, see [“Instantaneous Power Failure / Under-voltage Signal” on page 4-48](#).

The following table lists the functions related to the controlled deceleration at power loss feature. After making the wiring change, use function B050 to enable the feature. Use B051 to determine the point at which a decaying DC bus voltage will trigger the controlled deceleration. Use parameter B054 to specify an initial step-wise deceleration at power loss, and B053 to specify the duration of the linear deceleration. Note that this feature also affects the output signals that indicate instantaneous power fail and under-voltage conditions (see [“Instantaneous Power Failure / Under-voltage Signal” on page 4-48](#)).

Func. Code	Name	Description	Range
B050	Controlled deceleration and stop on power loss	Allows inverter control using regenerative energy to decelerate after loss of input power (requires jumper change)	Two option codes: 00Disable 01Enable
B051	DC bus voltage trigger level during power loss	Sets trigger for controlled deceleration and stop on power loss function	0.0 to 1000.V
B052	Over-voltage threshold during power loss	Sets over-voltage threshold for controlled deceleration function	0.0 to 1000.V
B053	Deceleration time setting during power loss	Deceleration time inverter uses only at power loss	0.01 to 99.99 sec. / 100.0 to 999.9 sec. / 1000 to 3600 sec.
B054	Initial output frequency decrease during power loss	Sets the initial decrease in output frequency upon power loss	0.00 to 10.00 Hz

The timing diagram below shows a power loss scenario and the related parameter settings. During the controlled deceleration the inverter itself acts as a load to decelerate the motor. With either a high-inertia load or a short deceleration time (or both), it is possible that the inverter impedance will not be low enough to continue linear deceleration and avoid an over-voltage condition on the DC bus. Use parameter B052 to specify a threshold for the over-voltage. In this case, the inverter pauses deceleration (runs at constant speed). When the DC bus decays again below the threshold, linear deceleration resumes. The pause/resume process will repeat as necessary until the DC bus energy is depleted (under-voltage condition occurs).

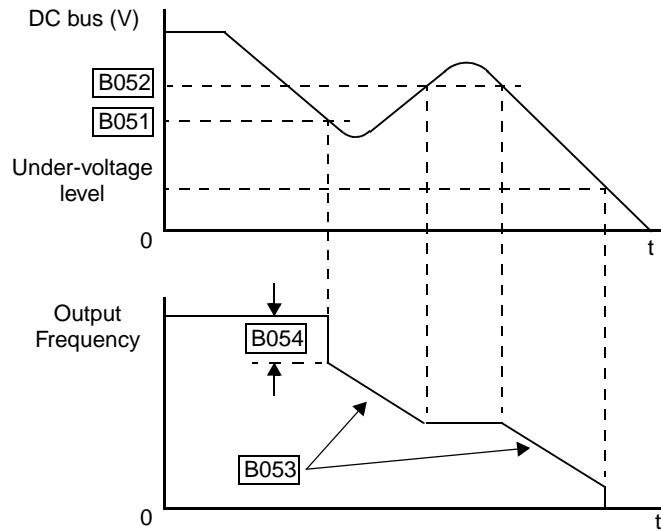

NOTE: (1) Be sure to set the *over-voltage threshold* greater than the *DC bus voltage trigger level* ($B052 > B051$) for proper operation.

(2) Once the power loss deceleration function starts, it will complete and stop the motor even if input power is restored. In that case, it automatically enables the Run mode again.

Connecting to PLCs and Other Devices

Hitachi inverters (drives) are useful in many types of applications. During installation, the inverter keypad (or other programming device) will facilitate the initial configuration. After installation, the inverter will generally receive its control commands through the control logic terminals or serial interface from another controlling device. In a simple application such as single-conveyor speed control, a Run/Stop switch and potentiometer will give the operator all the required control. In a sophisticated application, you may have a *programmable logic controller* (PLC) as the system controller with several connections to the inverter.

It is not possible to cover all the possible types of application in this manual. It will be necessary for you to know the electrical characteristics of the devices you want to connect to the inverter. Then, this section and the following sections on I/O terminal functions can help you quickly and safely connect those devices to the inverter.



CAUTION: It is possible to damage the inverter or other devices if your application exceeds the maximum current or voltage characteristics of a connection point.

The connections between the inverter and other devices rely on the electrical input/output characteristics at both ends of each connection, shown in the diagram to the right. The inverter can accept either sourcing or sinking type inputs from an external device (such as a PLC). A terminal jumper configures the input type, connecting the input circuit *common* to the supply (+) or (-). Detailed wiring examples are in [“Using Intelligent Input Terminals” on page 4-13](#). This chapter shows the inverter’s internal electrical component(s) at each I/O terminal and how to interface them with external circuits.

In order to avoid equipment damage and get your application running smoothly, we recommend drawing a schematic of each connection between the inverter and the other device. Include the internal components of each device in the schematic, so that it makes a complete circuit loop.

After making the schematic, then:

1. Verify that the current and voltage for each connection is within the operating limits of each device.
2. Make sure that the logic sense (active high or active low) of any ON/OFF connection is correct.
3. Verify inputs are configured correctly (sink/source) to interface to interface to any external devices (PLCs, etc.).
4. Check the zero and span (curve end points) for analog connections, and be sure the scale factor from input to output is correct.
5. Understand what will happen at the system level if any particular device suddenly loses power, or powers up after other devices.

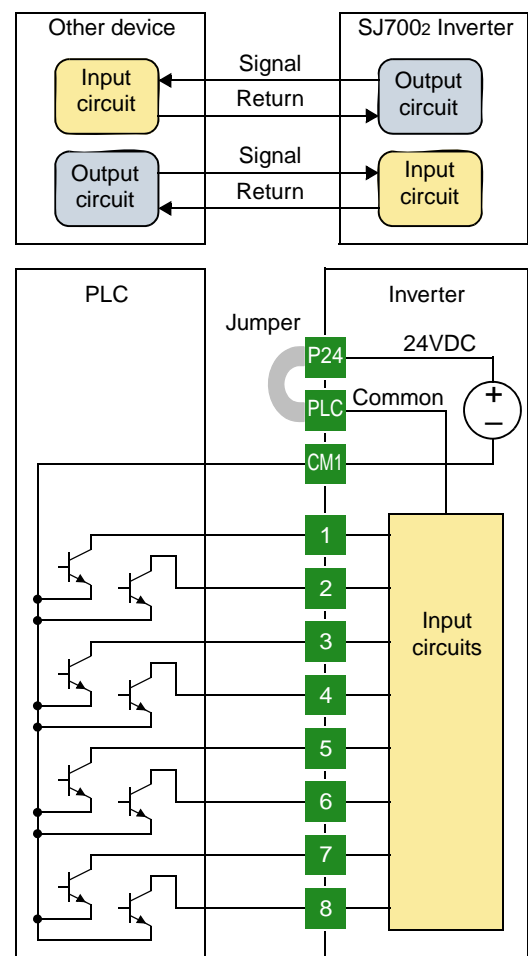

Example Wiring Diagram

The schematic diagram below provides a general example of logic connector wiring, in addition to basic power and motor wiring covered in Chapter 2. The goal of this chapter is to help you determine the proper connections for the various terminals shown below for your specific application needs.

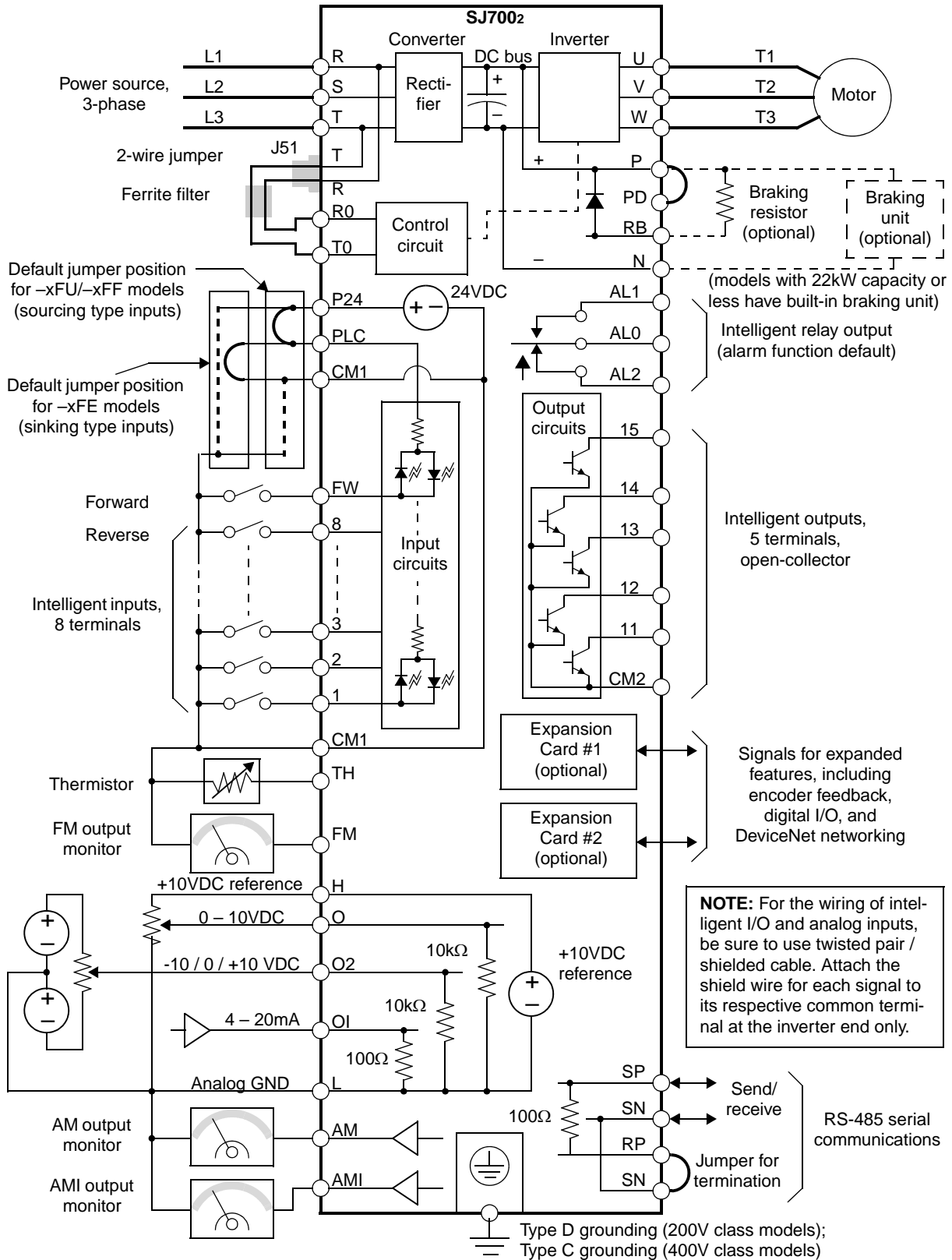

Operations and Monitoring

Specifications of Control and Logic Connections

The control logic connector board is removable for wiring convenience as shown below (first, remove two retaining screws). The small connector to the left is for serial communications.

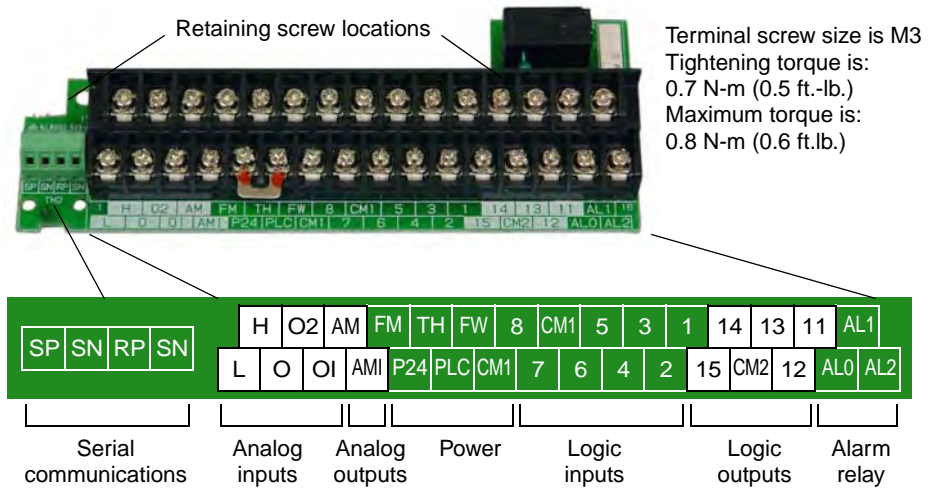

Specifications for the logic connection terminals are in the following table:

Terminal Name	Description	Ratings and Notes
[P24]	+24V power for inputs	24VDC supply, 100 mA max.
[CM1]	+24V common	Common for 24V supply, [FW], [TH], inputs [1] to [8], and [FM]. (Note: Do not ground)
[PLC]	Common for logic inputs	Common for input terminals [1] to [8], jumper to CM1 for sinking, jumper to P24 for sourcing
[CM2]	Common for logic outputs	Common for output terminals [11] to [15]
[1], [2], [3], [4], [5], [6], [7], [8]	Intelligent (programmable) discrete logic inputs	27VDC max. (use [P24] or an external supply referenced to terminal [CM1]), 4.7kΩ input impedance
[FW]	Forward/stop command	27VDC max. (use [P24] or an external supply referenced to terminal [CM1]), 4.7kΩ input impedance
[11], [12], [13], [14], [15]	Intelligent (programmable) discrete logic outputs	Open collector type, 50mA max. ON state current, 27 VDC maximum OFF state voltage
[TH]	Thermistor input	Reference to [CM1], min. thermistor power 100mW
[FM]	PWM output	0 to 10VDC, 1.2 mA max., 50% duty cycle
[AM]	Voltage analog output	0 to 10VDC, 2 mA max.
[AMI]	Current analog output	4-20 mA, nominal load impedance 250Ω
[L]	Common for analog inputs	Sum of [OI], [O], and [H] currents (return)
[OI]	Analog input, current	4 to 19.6 mA range, 20 mA nominal, 100Ω input impedance
[O]	Analog input, voltage	0 to 9.6 VDC range, 10VDC nominal, 12VDC max., input impedance 10 kΩ
[O2]	Analog input, voltage 2	-9.6 to 9.6 VDC range, ±10VDC nominal, ±12VDC max., input impedance 10 kΩ
[H]	+10V analog reference	10VDC nominal, 10 mA max.
[AL0]	Relay common contact	Contacts AL0-AL1, maximum loads: 250VAC, 2A; 30VDC, 8A resistive load 250VAC, 0.2A; 30VDC, 0.6A inductive load Contacts AL0-AL2, maximum loads: 250VAC, 1A; 30VDC 1A max. resistive load 250VAC, 0.2A; 30VDC, 0.2A max. inductive load Min. loads: 100 VAC, 10mA; 5VDC, 100mA
[AL1]	Relay contact, normally closed	
[AL2]	Relay contact, normally open	

Be sure to keep the control logic wiring separated from the power terminal wiring. In the case of model -3150Hxx, the drawing below shows how route control circuit wiring.

1. Separate the control circuit wiring into two bundles to make use of available space.
2. Route the wiring from the control terminal block to the wiring plate. Continue routing past the PCB attachment plate to the wiring exit area.
3. Secure the control wiring to the PCB attachment plate with cable ties.

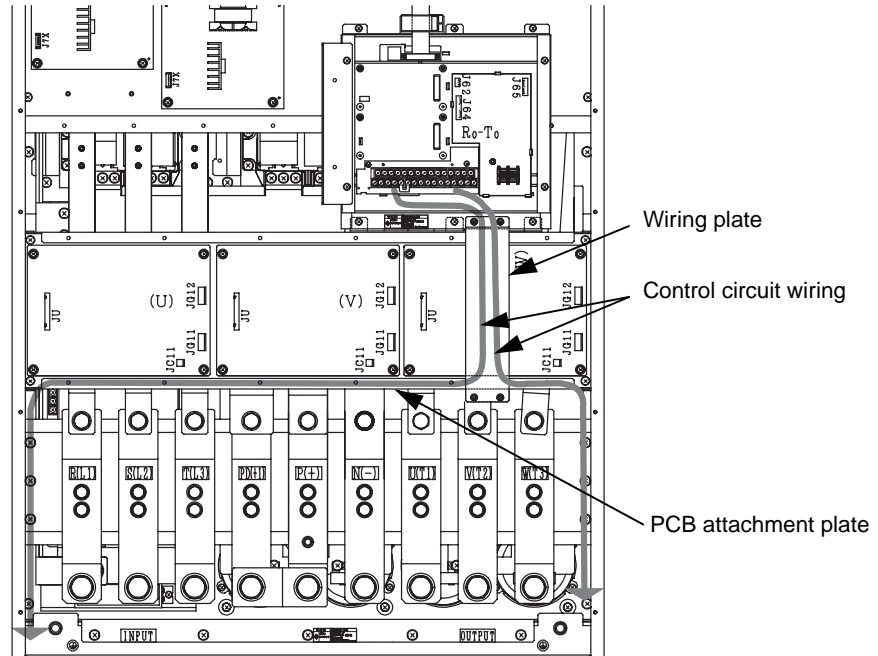

Input Terminal Listing

Use the following table to locate pages for intelligent input material in this chapter.

Intelligent INPUTS				Intelligent INPUTS			
Symbol	Code	Name	Page	Symbol	Code	Name	Page
RV	01	Reverse Run/Stop	4-15	TRQ2	42	Torque limit select, bit 2 (MSB)	4-30
CF1	02	Multi-speed select, Bit 0 (LSB)	4-15	PPI	43	P / PI mode selection	4-26
CF2	03	Multi-speed select, Bit 1	4-15	BOK	44	Brake confirmation signal	4-32
CF3	04	Multi-speed select, Bit 2	4-15	ORT	45	Orientation (home search)	4-34
CF4	05	Multi-speed select, Bit 3 (LSB)	4-15	LAC	46	LAC: LAD cancel	4-34
JG	06	Jogging	4-18	PCLR	47	Position deviation reset	4-34
DB	07	External signal for DC injection braking	4-19	STAT	48	Pulse train position cmd enable	4-34
				ADD	50	ADD frequency enable	4-34
SET	08	Set (select) second motor data	4-19	F-TM	51	Force terminal mode	4-35
2CH	09	2-stage accel and decel	4-20	ATR	52	Torque control enable	4-35
FRS	11	Free-run stop	4-20	KHC	53	Clear cumulative power value	4-36
EXT	12	External trip	4-21	SON	54	Speed servo ON	4-37
USP	13	Unattended start protection	4-21	FOC	55	Current forcing	4-37
CS	14	Commercial power source enable	4-22	MI1	56	General-purpose input 1	4-38
SFT	15	Software lock	4-23	MI2	57	General-purpose input 2	4-38
AT	16	Analog input voltage/current sel.	4-24	MI3	58	General-purpose input 3	4-38
SET3	17	Set (select) 3rd motor data	4-19	MI4	59	General-purpose input 4	4-38
RS	18	Reset inverter	4-24	MI5	60	General-purpose input 5	4-38
STA	20	Start (3-wire interface)	4-25	MI6	61	General-purpose input 6	4-38
STP	21	Stop (3-wire interface)	4-25	MI7	62	General-purpose input 7	4-38
F/R	22	FW, RV (3-wire interface)	4-25	MI8	63	General-purpose input 8	4-38
PID	23	PID Disable	4-26	AHD	65	Analog holding command	4-38
PIDC	24	PID Clear	4-26	CP1	66	Multi-stage position select 1	4-39
CAS	26	Control gain setting	4-26	CP2	67	Multi-stage position select 2	4-39
UP	27	Remote control Up func.	4-28	CP3	68	Multi-stage position select 3	4-39
DWN	28	Remote control Down func.	4-28	ORL	69	Zero-return limit function	4-40
UDC	29	Remote control data clearing	4-28	ORG	70	Zero-return trigger function	4-40
OPE	31	Operator control	4-28	FOT	71	Forward drive stop	4-41
SF1-7	32-38	Multi-speed bits 1 to 7	4-15	ROT	72	Reverse drive stop	4-41
OLR	39	Overload restriction	4-29	SPD	73	Speed/position control select	4-41
TL	40	Torque limit enable	4-30	PCNT	74	Pulse counter input	4-42
TRQ1	41	Torque limit select, bit 1 (LSB)	4-30	PCC	75	Pulse counter clear	4-42

Output Terminal Listing

Use the following table to locate pages for intelligent output material in this chapter.

Intelligent OUTPUTS				Intelligent OUTPUTS			
Symbol	Code	Name	Page	Symbol	Code	Name	Page
RUN	00	Run signal	4-44	FBV	31	PID feedback second stage output	4-56
FA1	01	Freq. arrival type 1 – constant speed	4-44	NDc	32	Network detection signal	4-57
				LOG1	33	Logic output 1	4-58
FA2	02	Freq. arrival type 2 – over-frequency	4-44	LOG2	34	Logic output 2	4-58
				LOG3	35	Logic output 3	4-58
OL	03	Overload advance notice signal	4-46	LOG4	36	Logic output 4	4-58
OD	04	Output deviation for PID control	4-46	LOG5	37	Logic output 5	4-58
AL	05	Alarm signal	4-47	LOG6	38	Logic output 6	4-58
FA3	06	Freq. arrival type 3 – at freq.	4-44	WAC	39	Capacitor life warning	4-58
OTQ	07	Over-torque signal	4-48	WAF	40	Low cooling fan speed	4-59
IP	08	Instantaneous power failure signal	4-48	FR	41	Starting contact signal	4-59
UV	09	Under-voltage signal	4-48	OHF	42	Heatsink overheat warning	4-59
TRQ	10	In torque limit signal	4-51	LOC	43	Low output current signal	4-60
RNT	11	Run time over	4-51	MO1	44	General output 1	4-60
ONT	12	Power-ON time over	4-51	MO2	45	General output 2	4-60
THM	13	Thermal alarm signal	4-52	MO3	46	General output 3	4-60
BRK	19	Brake release signal	4-54	MO4	47	General output 4	4-60
BER	20	Brake error signal	4-54	MO5	48	General output 5	4-60
ZS	21	Zero speed detect	4-54	MO6	49	General output 6	4-60
DSE	22	Speed deviation maximum	4-54	IRDY	50	Inverter ready signal	4-61
POK	23	Positioning completion	4-54	FWR	51	Forward rotation signal	4-61
FA4	24	Freq. arrival type 4 – over-frequency (2)	4-44	RVR	52	Reverse rotation signal	4-61
				MJA	53	Major failure	4-61
FA5	25	Freq. arrival type 5 – at frequency (2)	4-44	WCO	54	[O] terminal window comparator	4-62
				WCOI	55	[OI] terminal window comparator	4-62
OL2	26	Overload advance notice signal (2)	4-46	WCO2	56	[O2] terminal window comparator	4-62
Odc	27	Analog [O] disconnect detect	4-55				
OIDc	28	Analog [OI] disconnect detect	4-55				
O2Dc	29	Analog [O2] disconnect detect	4-55				

Using Intelligent Input Terminals

Intelligent terminals [1], [2], [3], [4], [5], [6], [7], and [8] are identical, programmable inputs for general use. The input circuits can use the inverter's internal (isolated) +24V field supply (P24) to power the inputs. The input circuits connect internally to [PLC] as a common point. To use the internal supply to power the inputs, use the jumper as shown. Remove the jumper to use an external supply, or to interface to a PLC system (or other) that has solid state outputs. If you use an external supply or PLC system, its power return must connect to the [PLC] terminal on the inverter to complete the input circuit.

Input Wiring Examples

The following four input configurations are available to interface the inverter inputs to switches or the outputs of another system, such as a PLC.

Sinking inputs, internal supply

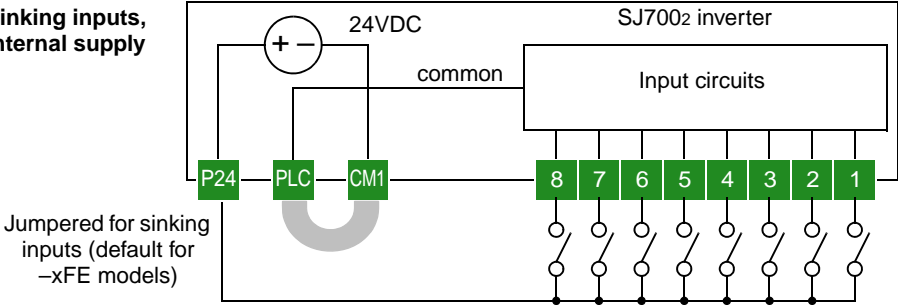

Sourcing inputs, internal supply

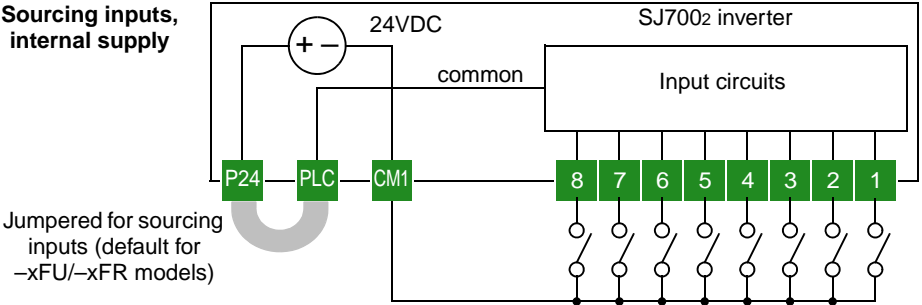

Sinking inputs, external supply

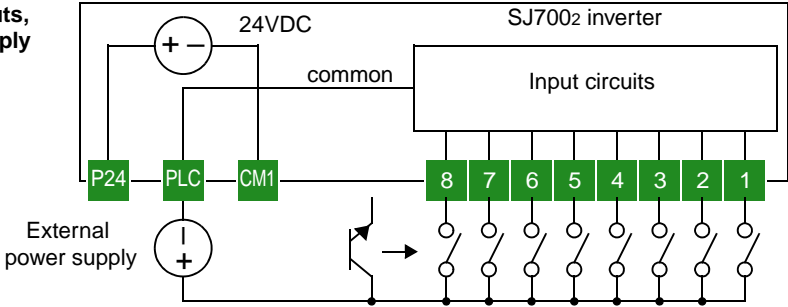

Sourcing inputs, external supply

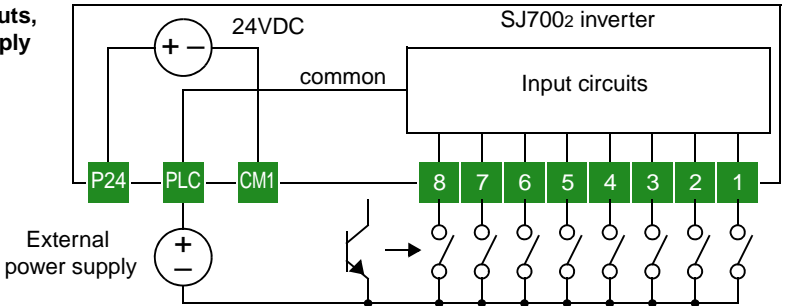

Operations and Monitoring

Wiring Diagram Conventions

The input wiring diagrams in this chapter are examples only. Default and non-default input terminal assignments are noted throughout; your particular assignments may be different. The wiring diagrams show the -xFU/-xFR model default [P24]-[PLC] jumper position (U.S./Jpn versions), as shown below on the left. The common (return) for inputs is [CM1] in this case. The diagram on the right shows the default jumper position and example input wiring for -xFE models (Europe version). For this case, the common (return) for inputs is [P24]. **Be sure the jumper position and return terminal used match your application wiring needs.**

-xFU/-xFR models (U.S./Jpn versions):

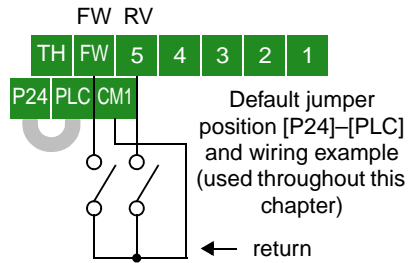

-xFE models (Europe version):

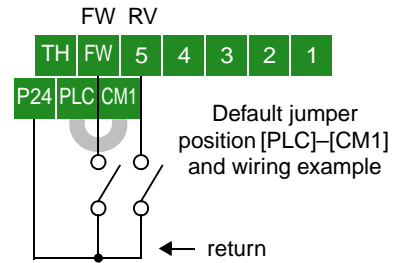

Forward Run/ Stop and Reverse Run/Stop Commands

Opt. Code and Symbol	[FW]*
	01=[RV]
Valid for Inputs	[1] to [8]
Required Settings	A002= 01
Default terminal	[FW]
* [FW] is a dedicated terminal	

When you input the Run command via the dedicated terminal [FW], the inverter executes the Forward Run command (high) or Stop command (low). When you input the Run command via the programmable terminal [RV], the inverter executes the Reverse Run command (high) or Stop command (low). Note the following:

- When the Forward Run and Reverse Run commands are active at the same time, the inverter enters the Stop Mode.
- When a terminal associated with either [FW] or [RV] function is configured for *normally closed*, the motor starts rotation when that terminal is disconnected or otherwise has no input voltage.
- The parameter F004, Keypad Run Key Routing, determines whether the single Run key issues a Run FWD command or Run REV command. However, it has no effect on the [FW] and [RV] input terminal operation.



WARNING: If the power is turned ON and the Run command is already active, the motor starts rotation and is dangerous! Before turning power ON, confirm that the external Run command is not active.

Multi-Speed Select, Binary Encoded

Opt. Code and Symbol	02 = [CF1]
	03 = [CF2]
	04 = [CF3]
	05 = [CF4]
Valid for Inputs	[1] to [8]
Required Settings	F001, A020 to A035, A019=00
Default terminals	[7]=[CF1], [8]=[CF2]*
Other terminals	Requires config.
* default for -FE2 models only	

The inverter can store up to 16 different fixed target frequencies (speeds) in parameters A020 to A035. Binary inputs select the speed through four of the intelligent terminals configured as binary-encoded inputs CF1 to CF4 per the table. These can be any of the eight inputs, and in any order. You can use fewer inputs if you need eight or fewer speeds.

Symbol	Function Name
CF1	Binary speed select, Bit 0 (LSB)
CF2	Binary speed select, Bit 1
CF3	Binary speed select, Bit 2
CF4	Binary speed select, Bit 3 (MSB)

Multi-speed	Input Function				Multi-speed	Input Function			
	CF4	CF3	CF2	CF1		CF4	CF3	CF2	CF1
Speed 0	0	0	0	0	Speed 8	1	0	0	0
Speed 1	0	0	0	1	Speed 9	1	0	0	1
Speed 2	0	0	1	0	Speed 10	1	0	1	0
Speed 3	0	0	1	1	Speed 11	1	0	1	1
Speed 4	0	1	0	0	Speed 12	1	1	0	0
Speed 5	0	1	0	1	Speed 13	1	1	0	1
Speed 6	0	1	1	0	Speed 14	1	1	1	0
Speed 7	0	1	1	1	Speed 15	1	1	1	1

NOTE: When choosing a subset of speeds to use, always start at the top of the table, and with the least-significant bit: CF1, CF2, etc.



The example with eight speeds in the figure below shows how input switches configured for CF1 – CF3 functions can change the motor speed in real time.

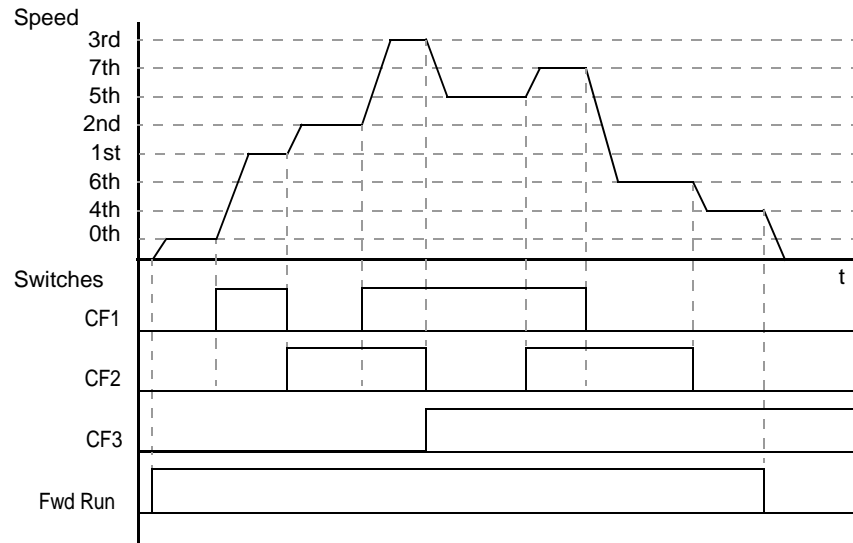

Multi-speed Override Feature - The multi-speed function can selectively override the external analog speed reference input. When the Frequency Source Setting parameter A001=01, the control terminal inputs determine the output frequency. At the same time, the inverter can use multi-speed select for output frequency if one or more intelligent inputs are configured as a CF type (CF1 to CF4). When all CF input(s) are OFF, the control terminal input determines the output frequency normally. When one or more CF input(s) are ON, then the corresponding multi-speed setting (see the table above) overrides and becomes the output frequency.

When programming the multi-speed settings, be sure to press the Store key each time and then set the next multi-speed setting. Note that when the Store key is not pressed, no data will be set.

When a multi-speed setting more than 50Hz(60Hz) is to be set, it is necessary to program the maximum frequency A004 high enough to allow that speed.

While using the multi-speed capability, you can monitor the output frequency with monitor function D001 during each segment of a multi-speed operation.

There are two ways to program the speeds into the registers A020 to A035:

1. Standard keypad programming:
 - a. Select each parameter A020 to A035.
 - b. Press the **(FUNC)** key to view the parameter value.
 - c. Use the **(↑)** and **(↓)** keys to edit the value.
 - d. Use the **(STR)** key to save the data to memory.
2. Programming using the CF switches:
 - a. Turn the Run command OFF (Stop Mode).
 - b. Turn inputs ON to select desired Multi-speed. Display the value of F001 on the digital operator.
 - c. Set the desired output frequency by pressing the **(↑)** and **(↓)** keys.
 - d. Press the **(STR)** key once to store the set frequency. When this occurs, F001 indicates the output frequency of the selected Multi-speed.
 - e. Press the **(FUNC)** key once to confirm that the indication is the same as the set frequency.
 - f. Repeat operations in 2. a) to 2. e) to set the frequency of other Multi-speeds. It can be set also by parameters A020 to A035 in the first procedure 1. a) to 1. d).

Multi-Speed Select, Bit-level

The Bit-level method of speed control uses up to seven intelligent inputs to select from up to eight speeds. Since the all-switches-OFF combination selects the first speed, you only need N-1 switches to select N speeds. With Bit-level speed control, only one input is normally active at a time. If multiple switches are ON, the lower numbered input takes precedence (determines the speed). The table and figure below show how the input combinations work.

Opt. Code and Symbol	32 = [SF1]
	33 = [SF2]
	34 = [SF3]
	35 = [SF4]
	35 = [SF5]
	36 = [SF6]
	37 = [SF7]
Valid for Inputs	[1] to [8]
Required Settings	F001, A020 to A035, A019=01
Default terminals	Requires config.

Symbol	Function Name
SF1	Bit-level Speed Select 1
SF2	Bit-level Speed Select 2
SF3	Bit-level Speed Select 3
SF4	Bit-level Speed Select 4
SF5	Bit-level Speed Select 5
SF6	Bit-level Speed Select 6
SF7	Bit-level Speed Select 7

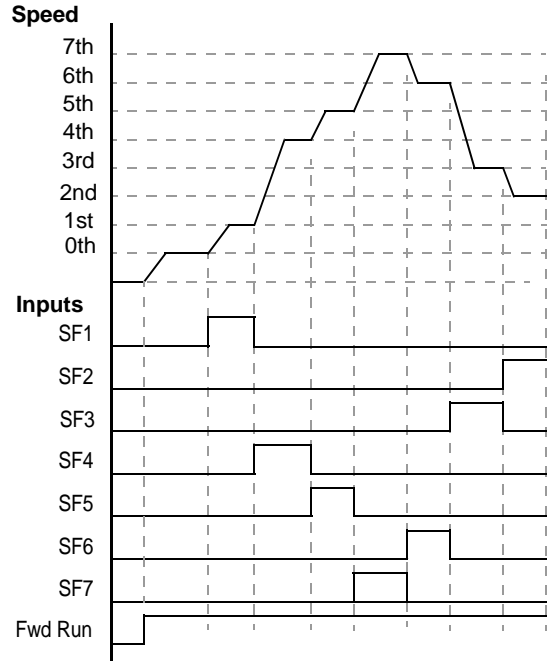

Multi-speed	Input Function						
	SF7	SF6	SF5	SF4	SF3	SF2	SF1
Speed 0	0	0	0	0	0	0	0
Speed 1	—	—	—	—	—	—	1
Speed 2	—	—	—	—	—	1	0
Speed 3	—	—	—	—	1	0	0
Speed 4	—	—	—	1	0	0	0
Speed 5	—	—	1	0	0	0	0
Speed 6	—	1	0	0	0	0	0
Speed 7	1	0	0	0	0	0	0

Jogging Command

Opt. Code	06
Symbol	[JG]
Valid for Inputs	[1] to [8]
Required Settings	A002= 01, A038>B082, A038 > 0, A039=00 to 05
Default terminal	[3]

The Jog input [JG] is used to command the motor to rotate slowly in small increments for manual operation. The speed is limited to 10 Hz. The frequency for the jogging operation is set by parameter A038. Jogging does not use an acceleration ramp. Therefore setting the jogging frequency A038 too high will cause inverter tripping.

A jog command may arrive while the motor is running. You can program the inverter to either ignore or respond to a jog command in this case by using function A039. The type of deceleration used to end a motor jog is also selectable by programming function A039. Six jog mode options are defined below:

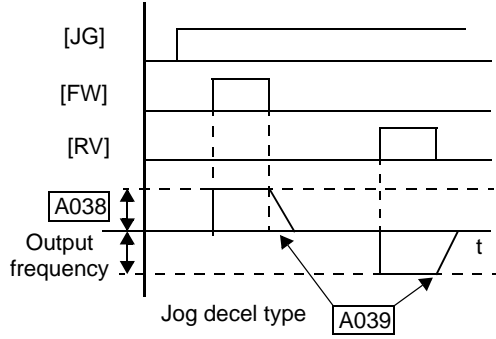

Jogging During Motor Operation		Jog Deceleration Method
Disabled, A039=	Enabled, A039=	
00	03	Free-run stop (coasting)
01	04	Deceleration (normal level) and stop
02	05	Use DC braking and stop

In the left example diagram below, the Jog command is ignored. In the right example diagram, a jog command interrupts a Run mode operation. However, if the Jog command turns ON before the [FW] or [RV] terminal turns ON, the inverter output turns OFF.

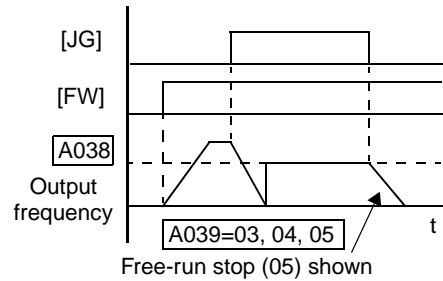
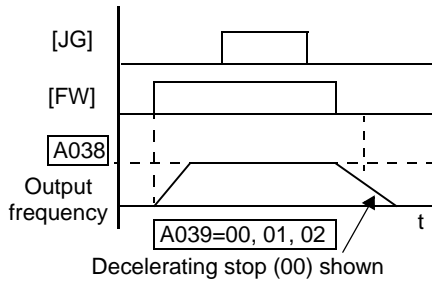

Note the following:

- Jogging is not performed when the value of A038 jogging frequency is smaller than the start frequency B082 or the value is 0 Hz.
- Be sure to turn ON [FW] or [RV] *after* the [JG] input turns ON for a jog operation.
- When setting A039 to 02 or 05, you must also set the DC braking parameters.

External Signal for DC Injection Braking

Opt. Code	07
Symbol	[DB]
Valid for Inputs	[1] to [8]
Required Settings	A053, A054
Default terminal	Requires config.

When the terminal [DB] is turned ON, the DC braking [DB] feature is enabled (regardless of A051 setting). Set the following parameters when the external DC braking terminal is to be used:

- A053 – DC braking delay time setting. The range 0.0 to 5.0 seconds.
- A054 – DC braking force setting. The range is 0 to 100% for models -004xxx to -1500xxx; 0 to 35% for models -1850xxx to -4000xxx.

The scenarios to the right help show how DC braking works in various situations.

1. Scenario 1 – The [FW] Run or [RV] Run terminal is ON. When the [DB] terminal turns ON, DC braking is applied. When the [DB] terminal turns OFF again, the inverter output ramps to the previous frequency.
2. Scenario 2 – The Run command is applied from the operator keypad. When the [DB] terminal turns ON, DC braking is applied. When the [DB] terminal turns OFF again, the inverter output remains OFF.
3. Scenario 3 – The Run command is applied from the operator keypad. When the [DB] terminal turns ON, DC braking is applied after the delay time set by A053 expires. The motor is in a free-running (coasting) condition during this delay time. When the [DB] terminal turns OFF again, the inverter output remains OFF.

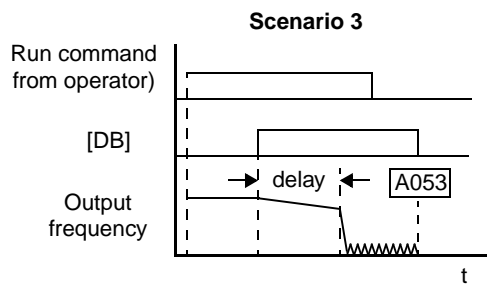
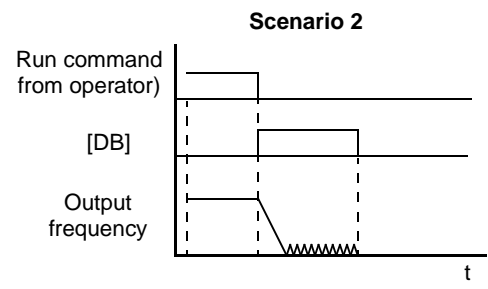
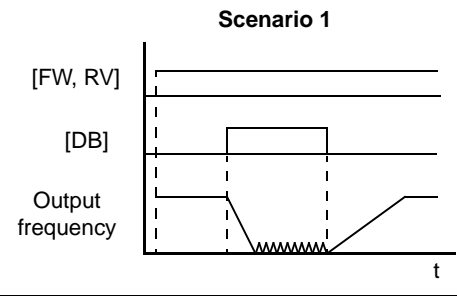

Note the following:

- Do not use the [DB] input continuously or for a long time when the DC braking force setting A054 is high (depends on the motor application).
- Do not use the [DB] feature for continuous or high duty cycle as a holding brake. The [DB] input is designed to improve stopping performance. Use a mechanical brake for holding a stop position.

Set Second or Third Motors

Opt. Code and Symbol	08=[SET]
	17=[SET3]
Valid for Inputs	[1] to [8]
Required Settings	(none)
Default terminal	Requires config.

If you assign the [SET] or [SET3] functions to an intelligent input terminal, you can select between two or three sets of motor parameters. You may assign one or both of these functions. These second and third parameters store alternate sets of motor characteristics. When terminal [SET] or [SET3] is turned ON, the inverter will use the second or third set of parameters accordingly, generating the frequency output to the motor. When changing the state of the [SET] or [SET3] input terminal, the change will not take effect until the inverter is stopped.

When you turn ON the [SET] or [SET3] input, the inverter operates per the second or third set of parameters, respectively. When the terminal is turned OFF, the output function returns to the original settings (first set of motor parameters). Refer to [“Configuring the Inverter for Multiple Motors” on page 4-76](#) for details.

Note the following:

- If the terminal state is changed while the inverter is running, the inverter continues using the current set of parameters until the inverter is stopped.
- If both SET and SET3 are ON at the same time, SET prevails and the 2nd motor parameters are in effect.

Two-stage Acceleration and Deceleration

Opt. Code	09
Symbol	[2CH]
Valid for Inputs	[1] to [8]
Required Settings	A092, A093, A094=0
Default terminal	[5]

When terminal [2CH] is turned ON, the inverter changes the rate of acceleration and deceleration from the initial settings (F002 and F003) to use the *second* set of acceleration/deceleration values (A092 and A093). When the terminal is turned OFF, the inverter returns to the original acceleration and deceleration time (F002 acceleration time 1 and F003 deceleration time 1). Use A092 (acceleration time 2) and A093 (deceleration time 2) to set the second stage acceleration and deceleration times.

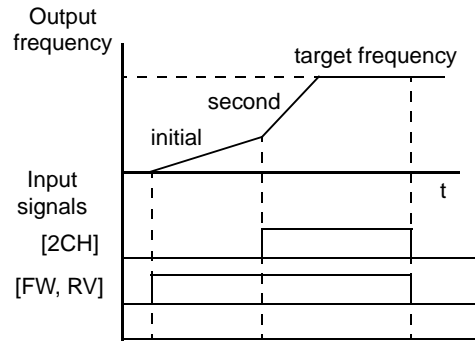

In the graph shown above, the [2CH] signal becomes active during acceleration. This causes the inverter to switch from using acceleration 1 (F002) to acceleration 2 (A092).

Note the following:

- Function A094 selects the method for second stage acceleration. It must be set = 00 to select the input terminal method in order for the [2CH] terminal assignment to operate.

Free-run Stop

Opt. Code	11
Symbol	[FRS]
Valid for Inputs	[1] to [8]
Required Settings	B003, B088, C011 to C018
Default terminal	[4]

When the terminal [FRS] is turned ON, the inverter turns OFF the output and the motor enters the free-run state (coasting). If terminal [FRS] is turned OFF, the output resumes sending power to the motor if the Run command is still active. The free-run stop feature works with other parameters to provide flexibility in stopping and starting motor rotation.

In the diagram below, parameter B088 selects whether the inverter resumes operation from 0 Hz (left graph) or the current motor rotation speed (right graph) when the [FRS] terminal turns OFF. The application determines the best setting.

Parameter B003 specifies a delay time before resuming operation from a free-run stop. To disable this feature, use a zero delay time.

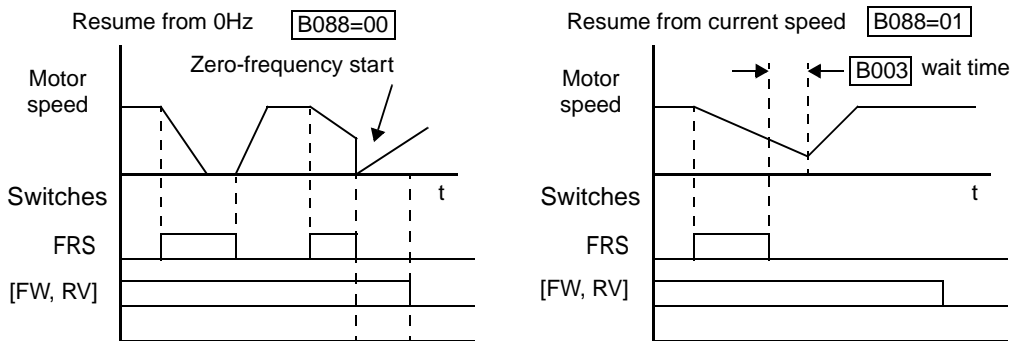

In the diagram above, [FRS] signal is active high. If you want the [FRS] terminal to be active low (normally closed logic), change the setting (C011 to C018) that corresponds to the input [1] to [8] that is assigned the [FRS] function (C001 to C008).

External Trip

Opt. Code	12
Symbol	[EXT]
Valid for Inputs	[1] to [8]
Required Settings	(none)
Default terminal	Requires config.

When the terminal [EXT] transitions OFF-to-ON, the inverter enters the trip state, indicates error code E12, and stops the output. This is a general purpose interrupt type feature, and the meaning of the error depends on what you connect to the [EXT] terminal. Even if [EXT] is turned OFF, the inverter remains in the trip state. You must reset the inverter or cycle power to clear the error, returning the inverter to the Stop Mode.

In the graph below, the [EXT] input turns ON during normal Run Mode operation. The inverter lets the motor free-run to a stop, and the alarm output turns ON immediately. When the operator initiates a Reset command, the alarm and error are cleared. When the Reset is turned OFF, the motor begins rotation since the Run command is already active.

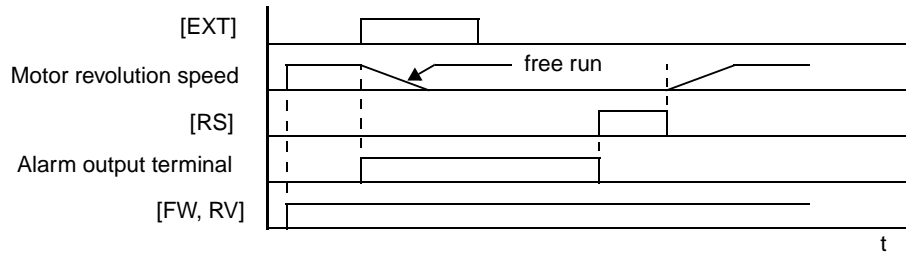

If the USP (Unattended Start Protection) feature is in use, the inverter will not automatically restart after cancelling the EXT trip event. In that case, it must receive either another Run command (OFF-to-ON transition), a keypad Reset command, or an [RS] intelligent terminal input signal.

Unattended Start Protection

Opt. Code	13
Symbol	[USP]
Valid for Inputs	[1] to [8]
Required Settings	(none)
Default terminal	[6]*
* Default for -FU2 models only; others require input configuration	

If the Run command is already present when power is turned ON, the inverter starts running immediately after powerup. The Unattended Start Protection (USP) function prevents that automatic startup. If the [USP] input is active, the inverter *will not* run without outside intervention. In this case, there are two ways to reset an alarm and resume running:

1. Turn the Run command OFF, or
2. Perform a reset operation by the terminal [RS] input or the keypad Stop/reset key

The three examples below show how the USP function works in the scenarios described at the bottom of the diagram. The error code E13 indicates the USP trip state and corresponds to the Alarm signal in the diagram.

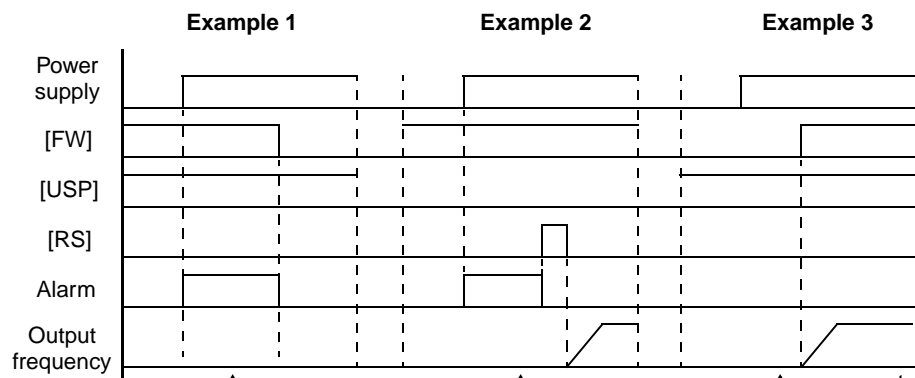

When USP is ON after powerup, the alarm (E13) will clear when the Run command (FW or RV) turns OFF.

If the alarm is cleared during Run command, the inverter output restarts automatically.

If the Run command is already OFF at powerup, the inverter output starts normally.

Note the following;

- Note that when a USP error occurs and it is canceled by a reset from the [RS] terminal input or keypad, the inverter restarts immediately.
- Even when the trip state is canceled by turning the terminal [RS] ON and OFF after an under-voltage trip E09 occurs, the USP function will be performed.

- When the Run command is active immediately after the power is turned ON, a USP error will occur. When this function is used, wait for at least three (3) seconds after powerup before applying a Run command.

Commercial Power Source Enable

Opt. Code	14
Symbol	[CS]
Valid for Inputs	[1] to [8]
Required Settings	B003, B007
Default terminal	Requires config.

The commercial power source switching function is useful in systems with excessive starting torque requirements. This feature permits the motor to be started “across the line,” sometimes called a *bypass* configuration. After the motor is running, the inverter takes over to control the speed. This feature can eliminate the need to oversize the inverter, reducing cost. However, additional hardware such as magnetic contactors will be required to realize this function. For example, a system may require 55KW to start, but only 15KW to run at constant speed. Therefore, a 15KW rated inverter would be sufficient when using the commercial power source switching.

The [CS] Commercial Power Source Enable input signal operation is as follows:

- OFF-to-ON transition signals the inverter that the motor is already running at powerup (via bypass), thus suppressing the inverter’s motor output in Run Mode.
- ON-to-OFF transition signals the inverter to apply a time delay (B003), frequency match its output to existing motor speed, and resume normal Run Mode operation

The following block diagram shows an inverter system with *bypass* capability. When starting the motor directly across the line, relay contacts Mg2 are closed, and Mg1 and Mg3 are open. This is the bypass configuration, since the inverter is isolated from the power source and motor. Then Mg1 contacts close about 0.5 to 1 second after that, supplying power to the inverter.

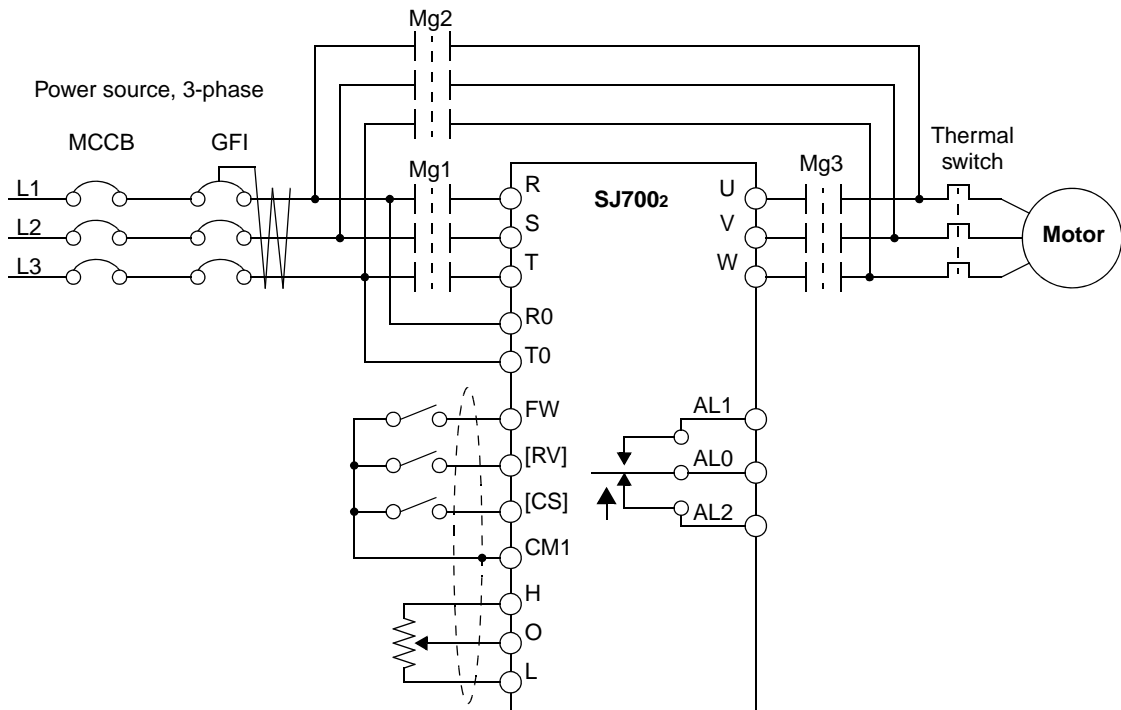

Switching to inverter control occurs after the motor is running at full speed. First, Mg2 relay contacts open. Then about 0.5 to 1 seconds later, relay Mg3 contacts close, connecting the inverter to the motor. The following timing diagram shows the event sequence:

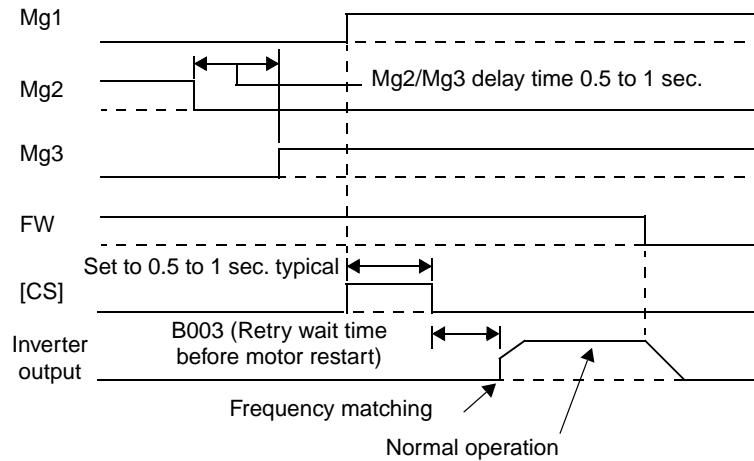

In the previous timing diagram, when the motor has been started across the line, Mg2 is switched OFF and Mg3 is switched ON. With the Forward command to the inverter already ON, the [CS] terminal is switched ON and relay Mg1 contacts close. The inverter will then read the motor RPM (frequency matching). When the [CS] terminal is switched OFF, the inverter applies the *Retry wait time before motor restart* parameter (B003).

Once the delay time has elapsed the inverter will then start and match the frequency (if greater than the threshold set by B007). If an over-current trip occurs during frequency matching, extend the retry wait time B003. If the ground fault interrupter breaker (GFI) trips on a ground fault, the bypass circuit will not operate the motor. When an inverter backup is required, take the supply from the bypass circuit GFI. Use control relays for [FW], [RV], and [CS].

Software Lock

Opt. Code	15
Symbol	[SFT]
Valid for Inputs	[1] to [8]
Required Settings	B031 (excluded from lock)
Default terminal	Requires config.

When the terminal [SFT] is ON, the data of all the parameters and functions (except the output frequency, depending on the setting of B031) is locked (prohibited from editing). The keypad and remote programming devices will be prevented from changing parameters. To edit parameters again, turn OFF the [SFT] terminal input. Use parameter B031 to select whether the output frequency is excluded from the lock state or is locked as well. Note the following:

- When the [SFT] terminal is turned ON, only the output frequency can be changed.
- Software lock can include the output frequency by setting B031.
- Software lock by the operator is also possible without the [SFT] terminal being used (B031).

Analog Input Current/Voltage Select

Opt. Code	16
Symbol	[AT]
Valid for Inputs	[1] to [8]
Required Settings	A001 = 01 A005 = 00 / 01 A006 = 00 / 01 / 02
Default terminal	[2]

The [AT] terminal operates in conjunction with parameter setting A005 to determine the analog input terminals that are enabled for current or voltage input. Setting A006 determines whether the signal will be bipolar, allowing for a reverse direction range. Note that current input signal cannot be bipolar and cannot reverse direction (must use [FW] and [RV] command with current input operation). The basic operation of the [AT] intelligent input is as follows:

- [AT] = ON and A005 = 00 – [AT] will enable terminals [OI]–[L] for current input, 4 to 20mA
- [AT] = ON and A005 = 01 – [AT] will enable terminals [O2]–[L] for voltage input
- [AT] = OFF – Terminals [O]–[L] are enabled for voltage input (A005 may be equal to 00 or 01) in this case

Be sure to set the frequency source setting A001=01 to select the analog input terminals. Please refer to [“Analog Input Operation” on page 4-63](#) for more information on bipolar input configuration, and the operating characteristics of analog inputs.

Reset Inverter

Opt. Code	18
Symbol	[RS]
Valid for Inputs	[1] to [8]
Required Settings	B003, B007, C102, C103
Default terminal	[1]

The [RS] terminal causes the inverter to turn OFF the motor output and execute a powerup reset. If the inverter is in Trip Mode, the reset cancels the Trip state. When the signal [RS] is turned ON and OFF, the inverter executes the reset operation. The minimum pulse width for [RS] must be 12 ms or greater. The alarm output will be cleared within 30 ms after the onset of the Reset command. Note the following:

- When the control terminal [RS] input is already ON at powerup for more than 4 seconds, the remote operator display is “R-ERROR COMM<2>” (the display of the digital operator is – – – –). However, the inverter has no error. To clear the digital operator error, turn OFF the terminal [RS] input and press one of the operator keys.
- The active edge (leading or trailing) of the [RS] signal is determined by the setting of C102.
- A terminal configured with the [RS] function can only be configured as a normally open contact. The terminal cannot be used in the normally closed contact state.
- When input power is turned ON, the inverter performs the same reset operation as it does when a pulse on the [RS] terminal occurs.

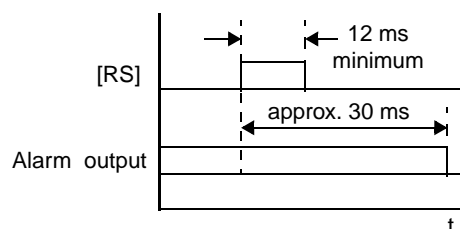

NOTE: For inverter models –1850Hxx to –4000Hxx: After an external reset input [RS] occurs, the internal cooling fan turn ON after stopping once.

WARNING: After the Reset command is given and the alarm reset occurs, the motor will restart suddenly if the Run command is already active. Be sure to set the alarm reset after verifying that the Run command is OFF to prevent injury to personnel.



Thermistor Thermal Protection

Opt. Code	—
Symbol	[TH]
Valid for Inputs	[TH only]
Required Settings	B098, B099, and C085
Default terminal	[TH]

Motors that are equipped with a thermistor can be protected from overheating. Input terminal [TH] is dedicated to sense thermistor resistance. The input can be set up (via B098 and B099) to accept a wide variety of NTC or PTC type thermistors. Use this function to protect the motor from overheating.

When a thermistor is connected between terminals [TH] and [CM1], the inverter checks for over-temperature and will cause a trip (E35) and turn OFF the output to the motor. Be sure the thermistor is connected to terminals [TH] and [CM1]. If the resistance is above or below (depending on whether NTC or PTC) the threshold the inverter will trip. When the motor cools down enough, the thermistor resistance will change enough to permit you to clear the error. Press the STOP/Reset key to clear the error.

An open circuit in the thermistor causes a trip, and the inverter turns OFF the motor output.

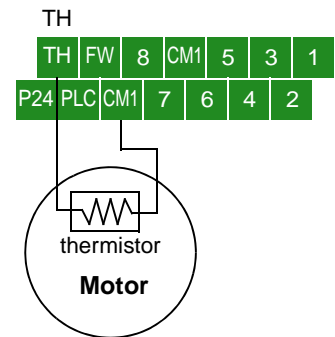

Three-wire Interface Operation

Opt. Code and Symbol	20=[STA]
	21=[STP]
	22=F/R
Valid for Inputs	[1] to [8]
Required Settings	A002=01
Default terminal	Requires config.

The 3-wire interface is an industry standard motor control interface. This function uses two inputs for momentary contact start/stop control, and a third for selecting forward or reverse direction.

Symbol	Function Name	Description
STA	Start Motor	Start motor rotation on momentary contact (uses acceleration profile)
STP	Stop Motor	Stop motor rotation on momentary open (OFF is active state), (uses deceleration profile)
F/R	Forward/Reverse	ON = Reverse; OFF = Forward

To implement the 3-wire interface, assign 20 [STA] (Start), 21 [STP] (Stop), and 22 [F/R] (Forward/Reverse) to three of the intelligent input terminals. Use momentary contacts for Start and Stop. Use a selector switch, such as SPST for the Forward/Reverse input. Be sure to set the operation command selection A002=01 for input terminal control of motor. Note the following:

- If you have a motor control interface that needs logic-level control (rather than momentary pulse control), use the [FW] and [RV] inputs instead.
- The STP logic is inverted. Normally the switch will be closed, so you open the switch to stop. In this way, a broken wire causes the motor to stop automatically (safe design).
- When you configure the inverter for 3-wire interface control, the dedicated [FW] terminal is automatically disabled. The [RV] intelligent terminal assignment is also disabled.

The diagram below shows the use of 3-wire control. STA (Start Motor) is an edge-sensitive input; an OFF-to-ON transition gives the Start command. The control of direction is level-sensitive, and the direction may be changed at any time. STP (Stop Motor) is also a level-sensitive input.

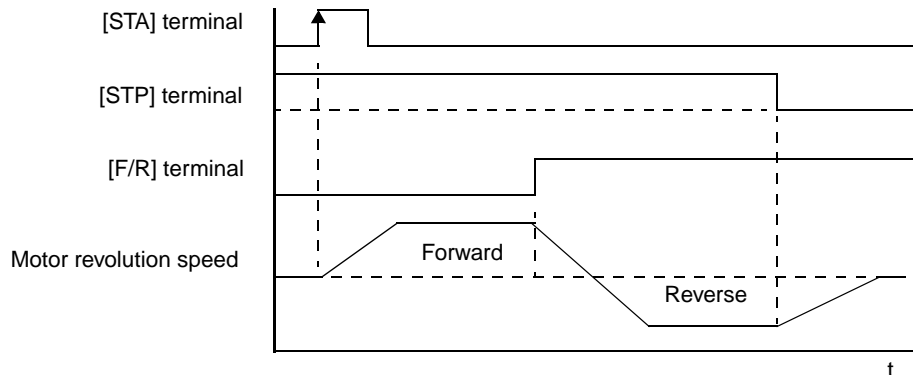

PID Disable and PID Clear

Opt. Code and Symbol	23=[PID]
	24=[PIDC]
Valid for Inputs	[1] to [8]
Required Settings	A071
Default terminal	Requires config.

The PID loop function is useful for controlling motor speed to achieve constant flow, pressure, temperature, etc. in many process applications.

PID Disable – This function temporarily suspends PID loop execution via an intelligent input terminal. It overrides the parameter A071 (PID Enable) to stop PID execution and return to normal motor frequency output characteristics. The use of PID Disable on an intelligent input terminal is optional. Of course, any use of the PID loop control requires setting PID Enable function A071=01.

PID Clear – This function forces the PID loop integrator sum = 0. So, when you turn ON an intelligent input configured as [PIDC], the integrator sum is reset to zero. This is useful when switching from manual control to PID loop control and the motor is stopped.

Note the following:

- The use of [PID] and [PIDC] terminals are optional. Use A071=01 if you want PID loop control enabled all the time.
- Do not enable/disable PID control while the motor is running (inverter is in Run Mode).
- Do not turn ON the [PIDC] input while the motor is running (inverter is in Run Mode).



CAUTION: Be careful not to turn PID Clear ON and reset the integrator sum when the inverter is in Run Mode (output to motor is ON). Otherwise, this could cause the motor to decelerate rapidly, resulting in a trip.

Internal Speed Loop Gain Settings

Opt. Code and Symbol	26=[CAS]
	43=[PPI]
Valid for Inputs	[1] to [8]
Required Settings	A044 / A244 / A344 = 03, 04, or 05
Default terminal	Requires config.

When sensorless vector control, 0Hz sensorless vector control, or vector control with sensor is selected for the control method, the Control Gain Switching function selects between two sets of gains in the internal speed loop. These gains are used in proportional and integral compensation. When Control Gain Switching is not selected for an intelligent input terminal, the default gains in effect correspond to the OFF state of [CAS].

Use [PPI] P/PI Control Switching to select between proportional and proportional-integral control.

Symbol	Function Name	Input State	Description
CAS	Control Gain Switching	ON	Gains in parameters H070, H071, and H072 are selected
		OFF	Gains in parameters H050, H051, H052; or, H250, H251, H252 (2nd motor) are selected
PPI	P / PI Control Switching	ON	Selects Proportional control (P)
		OFF	Selects Proportional-Integral control (PI)

The table below lists the functions and parameter settings related to internal speed loop gains.

Function Code	Parameter	Setting Range	Description
A044 / A244 / A344	Control method selection	03	SLV (does not use A344)
		04	0-Hz Domain SLV (does not use A344)
		05	V2 (does not use A244 or A344)
C001 - C008	Intelligent input selection	43	PPI : P/I switching
H005 / H205	Speed response	0.001 to 65.53	No dimension

Function Code	Parameter	Setting Range	Description
H050 / H250	PI proportional gain	0.0 to 999.9/1000	% gain
H051 / H251	PI integral gain	0.0 to 999.9/1000	% gain
H052 / H252	P proportional gain	0.01 to 10.00	No dimension
H070	PI proportional gain for switching	0.0 to 999.9/1000	% gain
H071	PI integral gain for switching	0.0 to 999.9/1000	% gain
H072	P proportional gain for switching	0.0 to 10.0	No dimension
H073	Gain switching time	0. to 999.	Milliseconds

The speed control mode is normally proportional-integral compensation (PI), which attempts to keep the deviation between the actual speed and speed command equal to zero. You can also select proportional (P) control function, which can be used for *droop* control (i.e. several inverters driving one load). *Droop* is the speed difference resulting from P control versus PI control at 100% output torque as shown in the graph. Set the P/PI switching function (option 43) to one of the intelligent input terminals [1] to [8]. When the P/PI input terminal is ON, the control mode becomes proportional control (P). When the P/PI input terminal is OFF, the control mode becomes proportional-integral control.

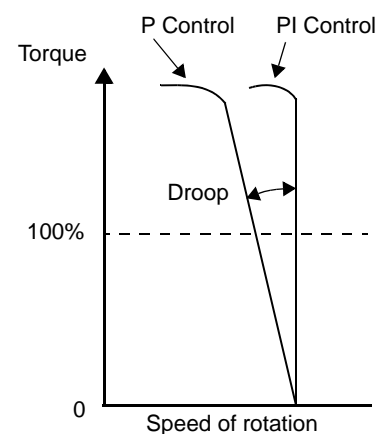

The proportional gain K_{pp} value determines the droop. Set the desired value using parameter H052. The relationship between the K_{pp} value and the droop is shown below:

$$\text{Droop} = \frac{10}{(K_{pp} \text{ Set Value})}(\%)$$

The relationship between the droop and the rated rotation speed is shown below:

$$\text{Droop} = \frac{\text{Speed error at rated torque}}{\text{Synchronous speed base frequency}}$$

Remote Control Up and Down Functions

The [UP] [DWN] terminal functions can adjust the output frequency for remote control while the motor is running. The acceleration time and deceleration time used with this function is the same as for normal operation ACC1 and DEC1 (2ACC1,2DEC1). The input terminals operate as follows:

Opt. Code and Symbol	27=[UP]
	28=[DWN]
	29=[UDC]
Valid for Inputs	[1] to [8]
Required Settings	A001 = 02; C101 = 01 (enables memory)
Default terminal	Requires config.

Symbol	Function Name	Description
UP	Remote Control UP Function	Accelerates (increases output frequency) motor from current frequency
DWN	Remote Control DOWN Function	Decelerates (decreases output frequency) motor from current frequency
UDC	Remote Control Data Clear	Clears the Up/down frequency memory

In the graph below, the [UP] and [DWN] terminals activate while the Run command remains ON. The output frequency responds to the [UP] and [DWN] commands.

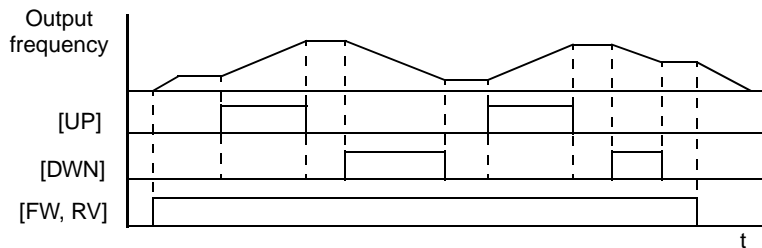

It is possible for the inverter to retain the frequency set from the [UP] and [DWN] terminals through a power loss. Parameter C101 enables/disables the memory. If disabled, the inverter retains the last frequency before an UP/DWN adjustment. Use the [UDC] terminal to clear the memory and return to the original set output frequency.

Force Operation from Digital Operator

Opt. Code	31
Symbol	[OPE]
Valid for Inputs	[1] to [8]
Required Settings	A001, A002 (set not equal to 02)
Default terminal	Requires config.

This function permits a digital operator interface to override the Run command source setting (A002) when it is configured for a source other than the operator interface. When the [OPE] terminal is ON, the operator interface Run command over-rides commands from input terminals (such as [FW], [RV]). The inverter will use the standard output frequency settings to operate the motor. When the [OPE] terminal is OFF, the Run command operates normally, as configured by A002.

When changing the [OPE] state during Run Mode (inverter is driving the motor), the inverter will stop the motor before the new [OPE] state takes effect. If the [OPE] input turns ON and the digital operator gives a Run command while the inverter is already running, the inverter stops the motor. Then the digital operator can control the motor.

Overload Restriction

Opt. Code	39
Symbol	[OLR]
Valid for Inputs	[1] to [8]
Required Settings	B021 – B023 (Set 1), B024 – B026 (Set 2)
Default terminal	Requires config.

The inverter constantly monitors the motor current during acceleration, deceleration, and constant speed. If the inverter reaches the overload restriction level, it adjusts the output frequency automatically to limit the amount of overload. This function prevents an over-current trip by inertia during rapid acceleration or large changes in load at constant speed. It also attempts to prevent an over-voltage trip on deceleration due to regeneration. It accomplishes this by temporarily suspending deceleration and/or increasing the frequency in order to dissipate regenerative energy. Once the DC bus voltage falls sufficiently, deceleration will resume.

OLR Parameter Selection – Two sets of overload restriction parameter settings and values are available as outlined in the table below.

Symbol	Function Name	Input State	Description
OLR	Overload Restriction Selection	ON	Selects Overload Restriction Set 2, B024, B025, B026 settings in effect
		OFF	Selects Overload Restriction Set 1, B021, B022, B023 settings in effect

Use the B021—B026 group of settings to configure the two set of parameters as needed. By assigning the Overload Restriction function [OLR] to an intelligent terminal, you can select the set of restriction parameters that is in effect.

Function	Function Code		Data or Range	Description
	Set 1	Set 2		
Overload Restriction Operation Mode	B021	B024	00	Disable
			01	Enabled during accel and constant speed
			02	Enabled during constant speed
			03	Enabled during accel, constant speed, and decel
Overload Restriction Setting	B022	B025	Rated current * 0.5 to rated current * 2	Current value at which the restriction begins
Deceleration Rate at Overload Restriction	B023	B026	0.1 to 30 seconds	Deceleration time when overload restriction operates

Note the following:

- If the overload restriction constant (B023 or B026) is set too short, an over-voltage trip during deceleration will occur due to regenerative energy from the motor.
- When an overload restriction occurs during acceleration, the motor will take longer to reach the target frequency, or may not reach it. The inverter will make the following adjustments:
 - a) Increase the acceleration time
 - b) Raise torque boost
 - c) Raise overload restriction level

The figure below shows the operation during an overload restriction event. The overload restriction level is set by B022 and B025. The overload restriction constant is the time to decelerate to 0Hz from maximum frequency. When this function operates, the acceleration time will be longer than the normal acceleration time.

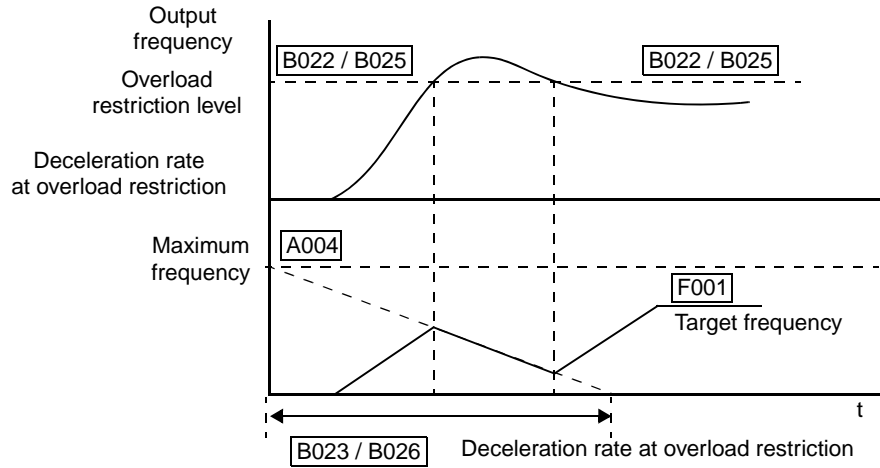

NOTE: The Overload Advance Notice function for intelligent outputs is related to Overload Restriction operation, discussed in [“Overload Advance Notice Signal” on page 4-46](#).

Torque Limit

Opt. Code and Symbol	40=[TL]
	41=[TRQ1]
	42=[TRQ2]
Valid for Inputs	[1] to [8]
Required Settings	B040, B041, B042, B043, B044
Default terminal	Requires config.

The Torque Limit function limits the motor output torque for sensorless vector control, sensorless vector control 0Hz domain, or vector control with feedback. Three intelligent inputs control the Torque Limit function:

Symbol	Function Name	Description
TL	Torque limit enable	Enables torque limit function when ON
TRQ1	Torque limit select 1, Bit 1 (LSB)	Binary encoded bit for quadrant select
TRQ2	Torque limit select 2, Bit 2 (MSB)	Binary encoded bit for quadrant select

In the torque limit function, the following operational modes are available (selected by B040):

1. Four-quadrant individual setting mode – This mode sets torque limit in 4 zones, forward driving and regenerating, reverse driving and regenerating. Limits for each quadrant are set with B041 – B044 individually.
2. Terminal selection mode – By use of torque limit select intelligent input terminals 1 and 2, this mode changes and uses torque limits 1 – 4 set in B041 – B044. Selected torque limit range is valid in all four quadrants. Inputs TRQ1 and TRQ2 apply only to terminal selection mode.
3. Analog input mode – This mode sets torque limit value by the voltage applied to terminal [O2] (referenced to [L] for ground). An input of 0 – 10V corresponds to the torque limit value of 0 to 200%. The selected torque limit value is valid in all four quadrants (whether forward or reverse move, driving or regenerating).
4. Expansion Cards 1 and 2 – This function is valid when using the expansion card (SJ-DG). Please refer to the SJ-DG instruction manual.

Intelligent Inputs		Torque limit parameter
TRQ2	TRQ1	
OFF	OFF	B041
OFF	ON	B042
ON	OFF	B043
ON	ON	B044

When the torque limit enable function [TL] is assigned to an intelligent input terminal, torque limiting occurs only when [TL] is ON. Both the 4-quadrant mode and terminal switching mode of torque limiting use input [TL] for enable/disable. When the [TL] input is OFF, the inverter always uses the default torque control limit of 200% maximum. That torque limit value corresponds to 200% of the maximum inverter output current. Therefore, the output torque also depends on the particular motor in use. When the over-torque output [OTQ] is assigned in the intelligent output selection, it turns ON when the inverter is performing torque limiting. When using the torque limit function at low speed, also use the overload restriction feature.

Code	Function	Data or Range	Description
A044 / A244	Control method selection	00	V/f Constant torque
		01	V/f Variable torque
		02	V/f Free-setting torque *1
		03	Sensorless vector *1
		04	Sensorless vector, 0 Hz domain *1
		05	Vector control with sensor *2
B040	Torque limit selection	00	4-quadrant individual setting
		01	Terminal selection
		02	Analog [O2] input
		03	Expansion card 1
		04	Expansion card 2
B041	Torque limit 1	0 to 200%	Forward-driving in 4-quadrant mode
B042	Torque limit 2	0 to 200%	Reverse-regenerating in 4-quadrant mode
B043	Torque limit 3	0 to 200%	Reverse-driving in 4-quadrant mode
B044	Torque limit 4	0 to 200%	Forward-regenerating in 4-quadrant mode
C001 to C008	Intelligent input terminal [1] to [8] function	40	Torque limit enable
		41	Torque limit selection, bit 1 (LSB)
		42	Torque limit selection, bit 2 (MSB)
C021 to C025	Intelligent output terminal [11] to [15] function	10	In torque limit

Note 1: Unavailable for A344
Note 2: Unavailable for A244 and A344

The 4-quadrant operation mode for torque limiting (B040=00) is illustrated in the figure to the right. The instantaneous torque depends on inverter activity (acceleration, constant speed, or deceleration), as well as the load. These factors determine the operating quadrant at any particular time. The parameters in B041, B042, B043 and B044 determine the amount of torque limiting that the inverter applies.

The terminal selection mode (B040=01) uses two intelligent inputs [TRQ1] and [TRQ2] for the binary-encoded selection of one of the four torque limit parameters B041, B042, B043 and B044.

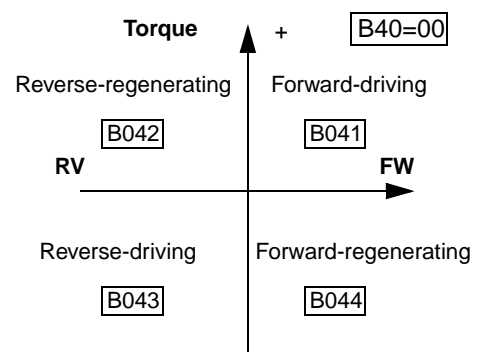

Operations and Monitoring

External Brake Control Function

Opt. Code	44
Symbol	[BOK]
Valid for Inputs	[1] to [8]
Required Settings	B120=01; Set B121 to B127
Default terminal	Requires config.

The External Brake Control function enables the inverter to control external electromechanical brake systems with a particular safety characteristic. For example, elevator control systems maintain the brake on the load until the drive motor has reached a *releasing* frequency (point at which the external mechanical brake is released). This ensures that the load does not have an opportunity to begin coasting before the inverter begins driving the motor. The External Brake Control function can be enabled by setting parameter B120=01.

The diagram below shows the signals that are important to the External Brake Control function.

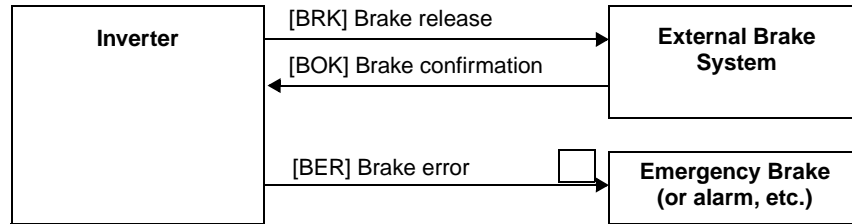

- Brake confirmation [BOK] turns ON to indicate that an external brake system has released (is not engaged). If external brake control is enabled (B120=01), then the [BOK] signal must work properly to avoid an inverter trip event.
- If [BOK] is not assigned to an intelligent input, then setting B124 is ignored.

The steps below describe the timing diagram of events on the following page.

1. When the Run command turns ON, the inverter begins to operate and accelerate to releasing frequency (B125).
2. After the output frequency arrives at the set releasing frequency (B125), the inverter waits for the brake release confirmation, set by B121. The inverter outputs the braking release signal [BRK]. However, if the output current of the inverter is less than the releasing current set by B126, the inverter does not turn ON the brake release output [BRK]. The lack of the proper current level indicates a fault (such as open wire to motor). In this case, the inverter trips and outputs the braking error signal [BER]. This signal is useful to engage an emergency brake to ensure the load does not move, if the primary braking system has failed.
3. While the brake release output [BRK] is ON, the inverter drives the motor but does not accelerate immediately. The inverter waits for confirmation from the external brake. When the external brake system properly releases, it signals the inverter by using the Brake OK input terminal [BOK]. If [BOK] is not assigned to an intelligent input, B124 is ignored.
4. When the brake operates properly and signals with the [BOK] input, the inverter waits for the required time for acceleration (B122), and then begins to accelerate to the set target frequency. If [BOK] is not assigned to an intelligent input, acceleration begins after the delay time set by B122 after [BRK] signal occurs.
5. When the Run command turns OFF, the procedure outlined above happens in reverse. The idea is to engage the brake before the motor comes completely to a stop. The inverter decelerates to the releasing frequency (B125) and turns the brake release output [BRK] OFF to engage the brake.
6. The inverter does not decelerate further during just the waiting time for brake confirmation (B121). If the brake confirmation signal does not turn OFF within the waiting time for brake confirmation, the inverter causes a trip alarm and outputs the brake error signal [BER] (useful for engaging an emergency brake system).
7. Normally, the brake confirmation signal [BOK] turns OFF, and the inverter waits the required waiting time. Then the inverter begins to decelerate again and brings motor and load to a complete stop (see timing diagram on next page).

The following table lists the parameters related to the External Brake Control function.

Code	Function	Data or Range	Description
B120	Brake control enable	00=Disable 01=Enable	Enables external brake control function within the inverter
B121	Brake waiting time for release	0.00 to 5.00 sec.	Sets the time delay after arrival at release frequency (B125) before the inverter outputs brake release signal [BRK]
B122	Brake wait time for acceleration	0.00 to 5.00 sec.	Sets time delay after brake confirmation signal [BOK] is received until the inverter begins to accelerate to the set frequency
B123	Brake wait time for stopping	0.00 to 5.00 sec.	Sets the time delay after brake confirmation signal [BOK] turns OFF (after [BRK] turns OFF) until decelerating the inverter to 0 Hz
B124	Brake wait time for confirmation	0.00 to 5.00 sec.	Sets the wait time for [BOK] signal after turn ON/OFF of [BRK] signal. If [BOK] is not received during the specified time, the inverter will trip with an external brake error [BER].
B125	Brake release frequency setting	0.00 to 99.99 Hz / 100.0 to 400.0 Hz	Sets the frequency at which the inverter outputs the brake release signal [BRK] after delay set by B121
B126	Brake release current setting	0% to 200% of rated current	Sets the minimum inverter current level above which the brake release signal [BRK] will be permitted
B127	Braking frequency	0 to 400 Hz (0 to 120 Hz for model -4000)	Sets the frequency at which the inverter outputs the braking signal

The diagram below shows the event sequence described in the steps on the previous page.

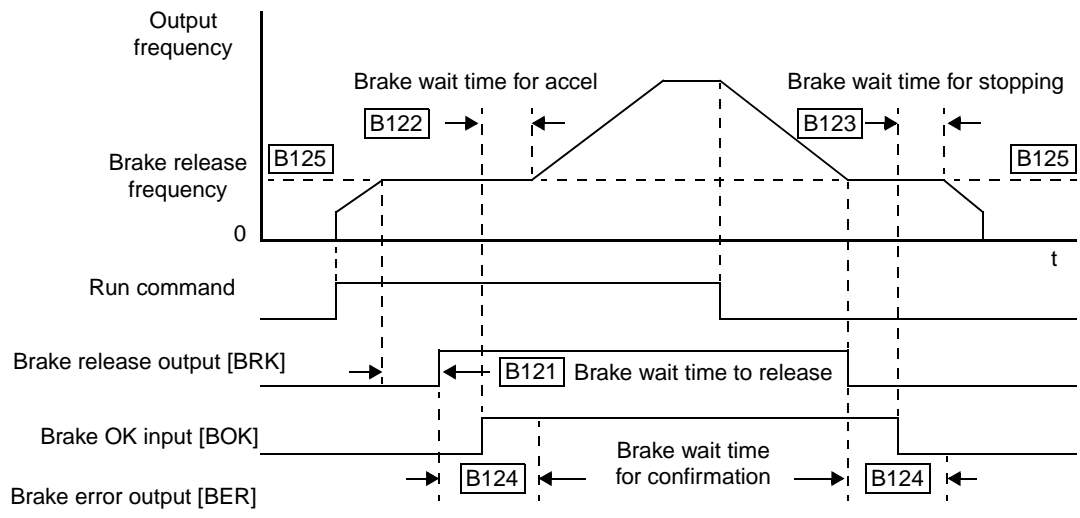

Expansion Card Input Signals

Other inputs listed below require the expansion card SJ-FB Encoder Feedback. Please see the SJ-FB manual for more information.

Opt. Code and Symbol	45=[ORT]
	46=[LAC]
	47=[PCLR]
	48=[STAT]
Valid for Inputs	[1] to [8]
Required Settings	B120=01; Set B121 to B126
Wiring terminals	...on SJ-FB Expansion Card

Symbol	Function Name	Description
ORT	Orientation	Orientation (home search sequence)
LAC	LAD Cancel	Cancels the linear acceleration/deceleration position control in the feedback card
PCLR	Position deviation clear	Forces the position error to zero
STAT	Pulse train input enable	Starts the pulse train control of motor frequency

The diagram below shows how the Input/Output connections for the SJ-FB feedback board. The inverter's internal connections and parameter configuration make these signals available on intelligent input and output terminals.

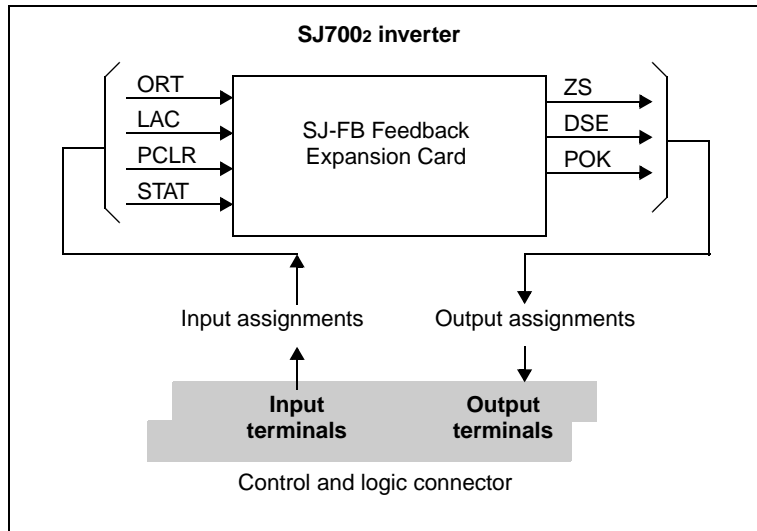

The information on outputs related to the SJ-FB expansion card is in [“Expansion Card Output Signals”](#) on page 4-54.

ADD Frequency Enable

Opt. Code	50
Symbol	[ADD]
Valid for Inputs	[1] to [8]
Required Settings	A145, A146
Default terminal	Requires config.

The inverter can add or subtract an offset value to the output frequency setting which is specified by A001 (will work with any of the five possible sources). The ADD Frequency is a value you can store in parameter A145. The ADD Frequency is summed with or subtracted from the output frequency setting only when the [ADD] terminal is ON. Function A146 selects whether to add or subtract. By configuring an intelligent input as the [ADD] terminal, your application can selectively apply the fixed value in A145 to offset (positively or negatively) the inverter output frequency in real time.

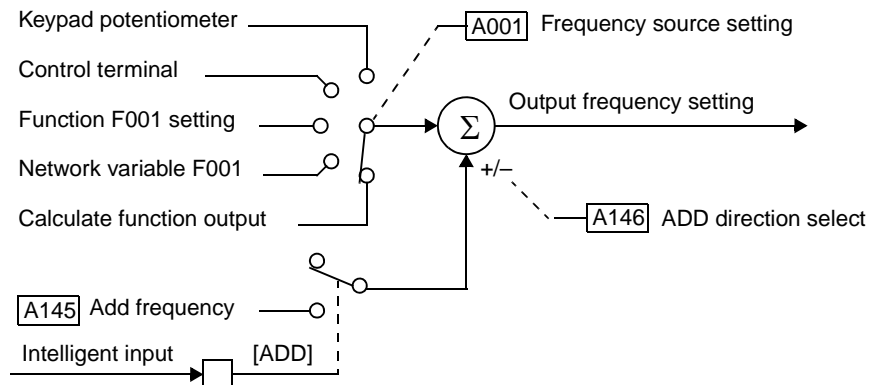

Force Terminal Mode

Opt. Code	51
Symbol	[F-TM]
Valid for Inputs	[1] to [8]
Required Settings	A001, A002
Default terminal	Requires config.

The purpose of this intelligent input is to allow a device to force the inverter to allow control of the following two parameters via the control terminals:

- A001 - Frequency source setting (01 = control terminals [FW] and [RV])
- A002 - Run command source setting (01 = control terminals [O] or [OI])

Some applications will require one or both settings above to use a source other than the terminals. You may prefer to normally use the inverter's keypad and potentiometer, or to use the ModBus network for control, for example. However, an external device can turn ON the [F-TM] input to force the inverter to (temporarily) allow control (frequency source and Run command) via control terminals. When the [F-TM] input is OFF, then the inverter uses the regular sources specified by A001 and A002 again.

When changing the [F-TM] state during Run Mode (inverter is driving the motor), the inverter will stop the motor before the new [F-TM] state takes effect.

Torque Control Enable

Opt. Code	52
Symbol	[ATR]
Valid for Inputs	[1] to [8]
Required Settings	A044 = 05, P033, P034, P035, P039, P040, P036, P037, P038
Monitor Settings	D009, D010, D012
Default terminal	Requires config.

The torque control enable function is available in the *vector control with encoder feedback* mode (A044 = 05). You can use the inverter not only in speed control or pulse train position control but also with the torque control function. Suitable applications include material winding machines.

The torque command input is enabled when the [ATR] intelligent input (assigned with option code 52) is ON. You can select one of four torque command input methods (digital operator and three analog input terminals) by the torque command input selection.

Code	Function	Data or Range	Description
P033	Torque command input selection	00	[O] terminal
		01	[OI] terminal
		02	[O2] terminal
		03	Inverter keypad (P034)
P034	Torque command setting	0. to 200. (%)	Torque setting for the input from the digital operator (P033 = 03)
P035	Torque command polarity select	00	Indicated by signal polarity at [O2] terminal
		01	Depends on motor direction
P039	Forward speed limit for torque-control mode	0.00 to maximum frequency (Hz)	—
P040	Reverse speed limit for torque-control mode	0.00 to maximum frequency (Hz)	—
P036	Torque bias mode	00	Disable
		01	Inverter keypad (P037)
		02	[O2] terminal input
P037	Torque bias value	-200. to 200. (%)	
P038	Torque bias polarity	00	Indicated by polarity
		01	Depends on motor direction

The following block diagram shows the torque control operation. If the measured speed exceeds the speed limit, the motor speed is controlled in proportional control mode.

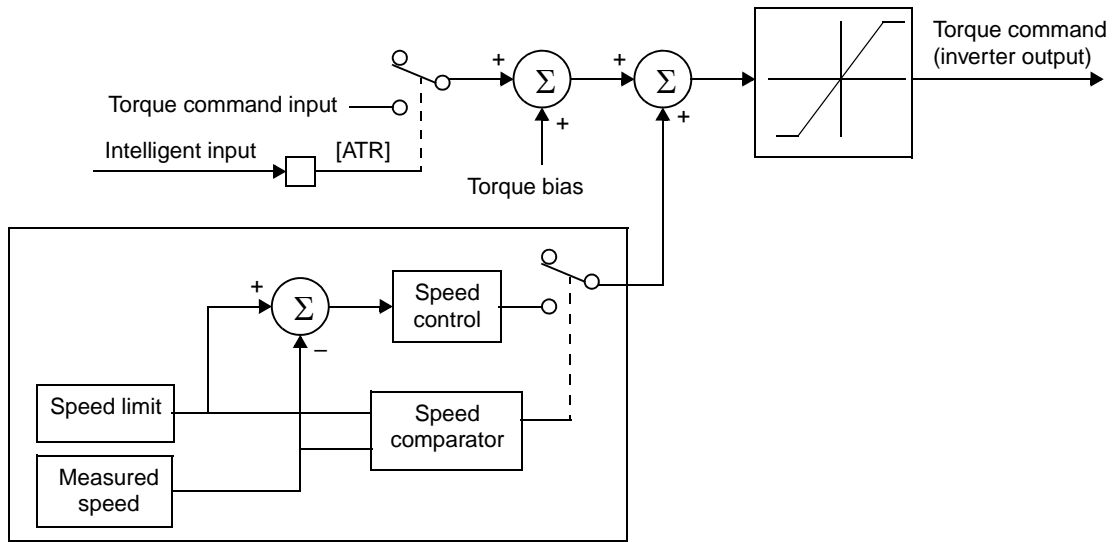

Clear Cumulative Power Value

When D015 cumulative power monitoring function is selected, the inverter displays the cumulative value of electric power input to the inverter. You can also convert the value to other engineering units by setting the related parameter gain (B079 cumulative input power display gain setting). The gain can be set within the range of 1 to 1000 (resolution = 1).

There are two ways to clear the cumulative power data:

- Set B078 = 01 and press the STR key on the digital operator.
- Configure an intelligent input for the [KHC] function (option code = 53). Turn ON the input to clear the cumulative power data.

When B079 cumulative input power display gain setting = 1000, cumulative power data up to 999000 kW/h can be displayed.

Opt. Code	53
Symbol	[KHC]
Valid for Inputs	[1] to [8]
Required Settings	B078, B079
Monitor Settings	D015
Default terminal	Requires config.

Operations and Monitoring

Speed Servo ON

Opt. Code	54
Symbol	[SON]
Valid for Inputs	[1] to [8]
Required Settings	A044
Default terminal	Requires config.

The servo-ON function allows you to set the inverter in a speed-servo-lock state with an intelligent input during operation. This function is available when A044=05 *vector control with sensor* for the characteristic V/f curve.

To use the servo-ON function, assign option code 54 to an intelligent input. After making the input assignment, the inverter will accept an operation command only when the [SON] terminal is ON.

If the [SON] terminal is turned OFF during inverter operation, the inverter output enters FRS mode (free-run stop). If the [SON] is turned ON again, the inverter restarts the motor according to function B088, Restart Mode After FRS.

The inverter does not allow [SON] terminal assignment and [FOC] (forcing function) assignment at the same time. If both are assigned, the [FOC] has priority (operates normally) and the [SON] function is not available.

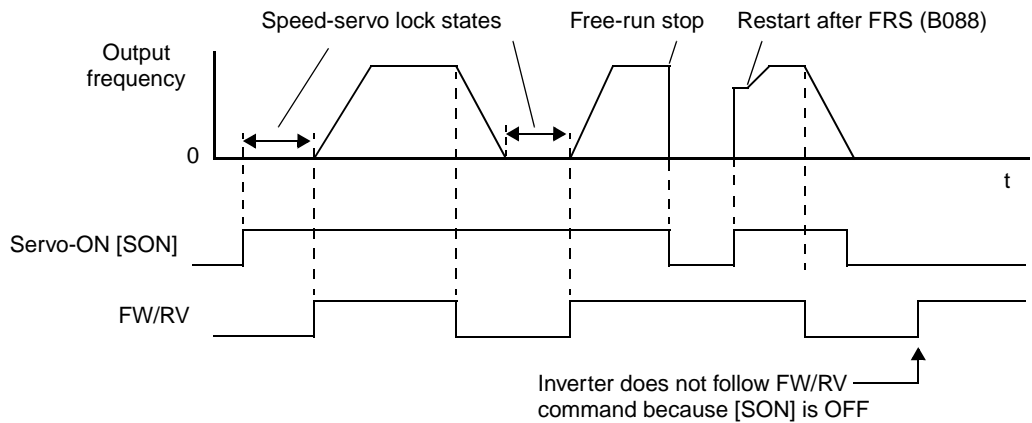

Current Forcing

Opt. Code	55
Symbol	[FOC]
Valid for Inputs	[1] to [8]
Required Settings	A044, A244
Default terminal	Requires config.

The current forcing function applies an excitation current to pre-build magnetic flux in the motor. The forcing function is available when one of the following vector control modes is configured for use at the inverter output:

- A044 = 03 sensorless vector control
- A044 = 04 0Hz-range sensorless vector control
- A044 = 05 vector control with sensor

To use current forcing, assign option code 55 to an intelligent input terminal. After making the input assignment, the inverter will accept an operation command only when the [FOC] terminal is ON.

If the [FOC] terminal is turned OFF during inverter operation, the inverter output enters FRS mode (free-run stop). If the [FOC] is turned ON again, the inverter restarts the motor according to function B088, Restart Mode After FRS.

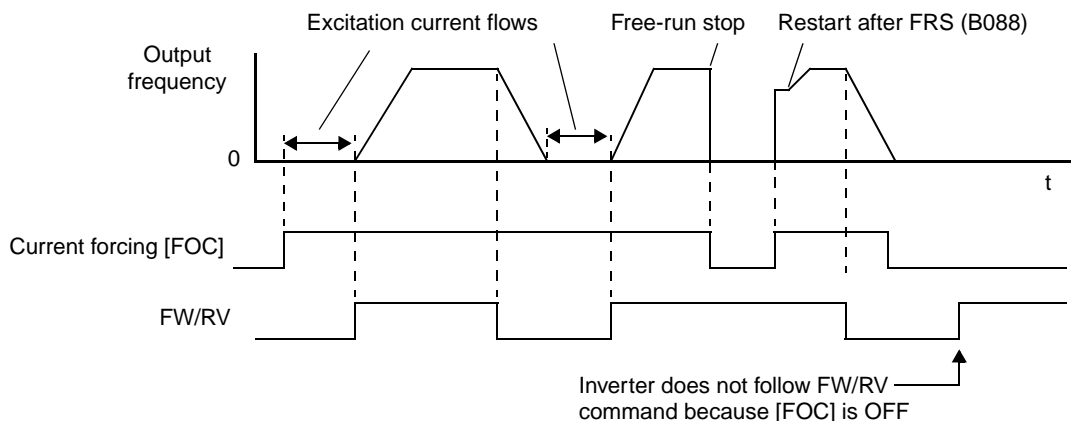

General Purpose Inputs 1-8

Refer to the Easy Sequence Instruction Manual for information on how to configure and use the general purpose inputs MI1 to MI8.

Opt. Code and Symbol	56=[MI1]
	57=[MI2]
	58=[MI3]
	59=[MI4]
	60=[MI5]
	61=[MI6]
	62=[MI7]
	63=[MI8]
Valid for Inputs	[1] to [8]
Required Settings	See Easy Sequence
Default terminal	Requires config.

Analog Holding Command

Opt. Code	65
Symbol	[AHD]
Valid for Inputs	[1] to [8]
Required Settings	C101
Default terminal	Requires config.

The analog holding function causes the inverter to sample and hold the analog command (external analog input). The hold operation begins when the intelligent input [AHD] (assign option code 65) turns ON. While [AHD] terminal is ON, the Up/Down function uses the held input level as the reference speed (frequency) value. Set parameter C101 (Up/Down memory Mode Selection) = 01 to store the last frequency adjusted by UP/DWN in memory.

If the inverter power is cycled (OFF and ON) or the [RS] reset terminal receives a reset (ON and OFF) while [AHD] is ON (holding analog value), the data held at the moment of power OFF or Reset ON will be used.

The wave form below shows a typical sequence for use of the Analog Holding Command.

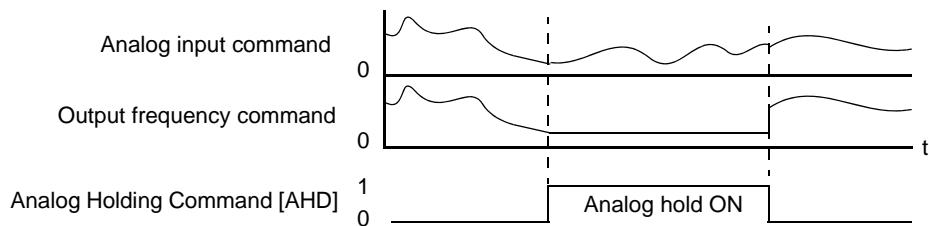

NOTE: Frequent use of the Analog Hold function may damage the corresponding flash memory register in the inverter.

Multi-stage Position Select 1, 2, and 3

Three Multi-stage Position Select inputs are binary-encoded to select one of eight settings, P060 to P067. Input [CP1] is the LSB; [CP3] is the MSB. If no position select inputs are assigned, P060 becomes the default position setting.

Opt. Code and Symbol	66=[CP1]
	67=[CP2]
	68=[CP3]
Valid for Inputs	[1] to [8]
Required Settings	P060 to P067, C169
Default terminal	Requires config.

Function Code	Multi-Position	Input Function		
		[CF3]	[CF2]	[CF1]
P060	Position setting 0	0	0	0
P061	Position setting 1	0	0	1
P062	Position setting 2	0	1	0
P063	Position setting 3	0	1	1
P064	Position setting 4	1	0	0
P065	Position setting 5	1	0	1
P066	Position setting 6	1	1	0
P067	Position setting 7	1	1	1

The three multi-stage position select inputs [CF1], [CF2], and [CF3] are binary-encoded. When more than one input changes state to select a position, it is possible that skewing of input transitions would briefly select undesired intermediate positions. To avoid this problem, a determination time feature is available. Parameter C169 sets a delay time that applies uniformly to all three inputs. It operates according to the following process:

- The determination timer is initialized upon an input transition. The transition is not yet transferred to the output.
- The timer is initialized again if an input transitions before the timer expires.
- When the timer expires, the state of all three position select inputs is transferred to the output (to generate a new position selection, P060 to P067).

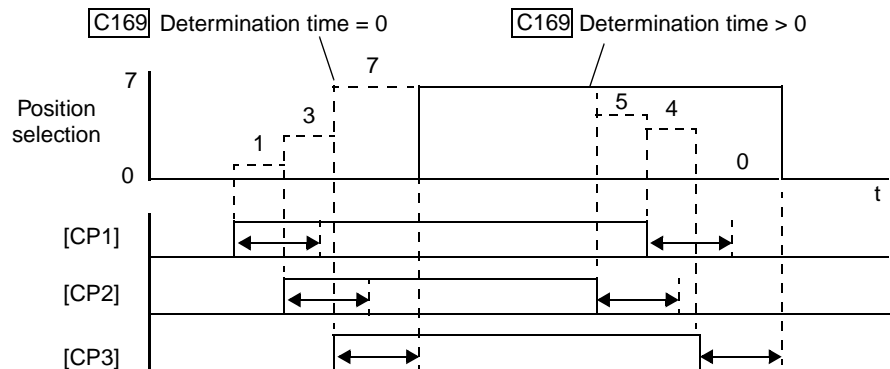

Note that excessively long determination time settings will reduce the overall performance of the position select inputs.

Operations and Monitoring

Zero-Return Functions

Opt. Code and Symbol	69=[ORL] 70=[ORG]
Valid for Inputs	[1] to [8]
Required Settings	P068, P069, P070, P071
Default terminal	Requires config.

A *zero-return* operation (also called a *home-return*) occurs when the motor moves the load to a particular starting position. Using parameter P068, you may select one of three possible types of zero-return operations. Parameter P069 selects the search direction. The *zero pulse input* (also called *zone input*) signals the arrival at the zero position.

Code	Function	Data	Description
P068	Zero-return mode selection	00	Low speed
		01	High speed 1
		02	High speed 2
P069	Zero return direction selection	00	Forward
		01	Reverse

It is generally a requirement (or good practice) to perform a zero-return operation after every powerup of the inverter. It is possible that the previous power OFF occurred when the load was not at zero position. Or, it may be that an external force moved the load during the power OFF period. If you do not perform a zero-return operation after power ON, then the inverter uses the current position at powerup as the zero position.

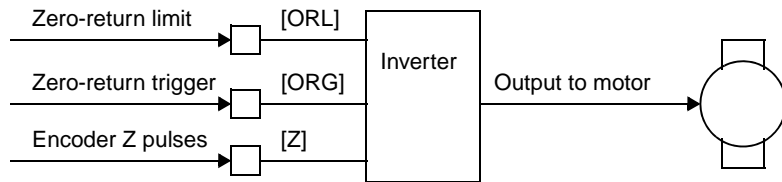

The three available zero-return modes differ in the overall search speed, final approach direction to the origin, and the limit switch input transition (or encoder pulse, if used) causing the final stop. Choose the zero-return mode that best fits your application.

Low-speed Zero Return:

1. Motor accelerates for the specified acceleration time to the low zero-return speed
2. Motor runs at the low zero-return speed
3. Inverter stops motor and sets position value to zero when [ORL] signal turns ON

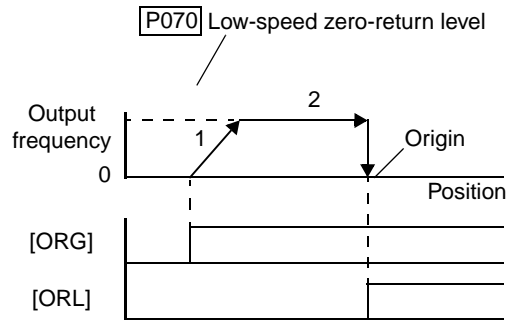

High-speed 1 Zero Return:

1. Motor accelerates for specified acceleration time to high zero-return speed
2. Motor runs at high zero-return speed
3. Motor starts deceleration when [ORL] signal turns ON
4. Motor runs in reverse direction at low-speed zero-return speed
5. Inverter stops motor and sets position value to zero when [ORL] signal turns OFF

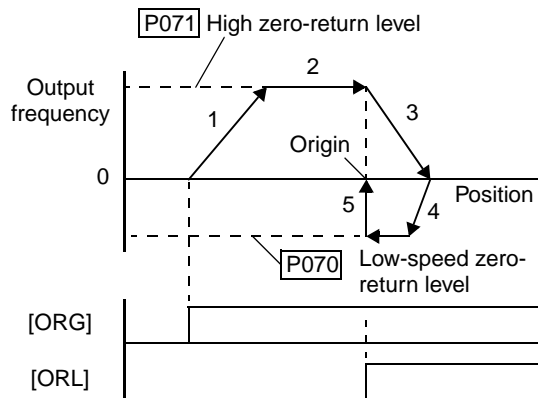

High-speed 2 Zero Return:

1. Motor accelerates for specified acceleration time to high zero-return speed
2. Motor runs at high zero-return speed
3. Motor starts deceleration when [ORL] signal turns ON
4. Motor runs in reverse direction at low-speed zero-return speed
5. Motor starts deceleration to stop when [ORL] signal turns OFF
6. Motor accelerates in forward direction to low-speed zero return level
7. Inverter stops motor and sets position value to zero when next [Z] signal pulse occurs

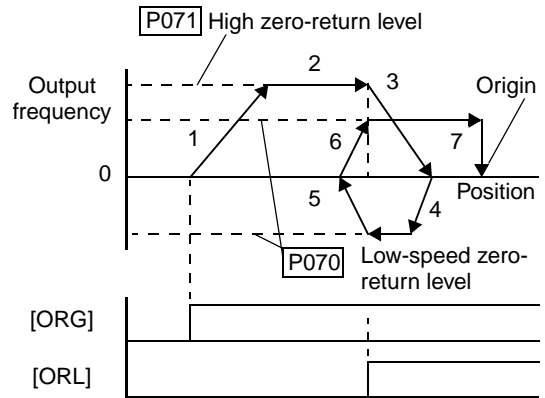

Forward/Reverse Drive Stop

Opt. Code and Symbol	71=[FOT]
	72=[ROT]
Valid for Inputs	[1] to [8]
Required Settings	none
Default terminal	Requires config.

The forward/reverse drive stop function prevents the motor from moving a load outside a desired position range. The end of travel in each direction must cause the appropriate input signal, [FOT] or [ROT], to turn ON. Typically a limit switch or proximity switch is used to generate these signals.

If the [FOT] turns ON during forward rotation (or [ROT] turns ON during reverse rotation), the inverter limits the motor torque to 10% in the current direction of travel.

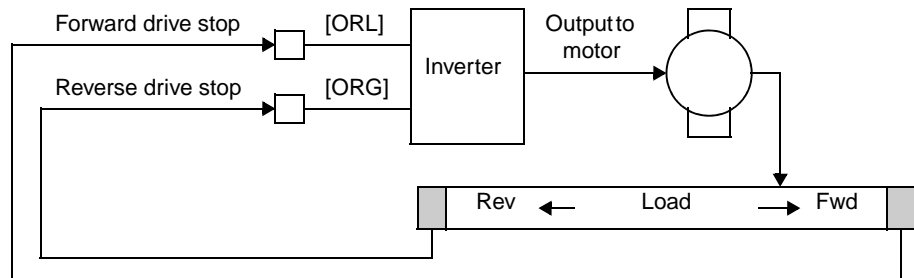

Operations and Monitoring

Speed/Position Control Select

Opt. Code	73
Symbol	[SPD]
Valid for Inputs	[1] to [8]
Required Settings	A044=05, P012
Default terminal	Requires config.

Turn ON the [SPD] terminal input to perform speed control while in absolute position control mode. The direction of rotation depends on the operation command (FWD or REV). When switching from speed control to position control, be sure to verify the sign of the value set in the operation command.

While the [SPD] terminal is OFF, the current position count remains at zero. If the [SPD] terminal is turned OFF during motor operation, the control mode switches to position control and pulse counting begins, starting from zero. If the target position value is also zero, the inverter stops the motor at the current position. Otherwise, rotation continues until motor rotation arrives at the target position.

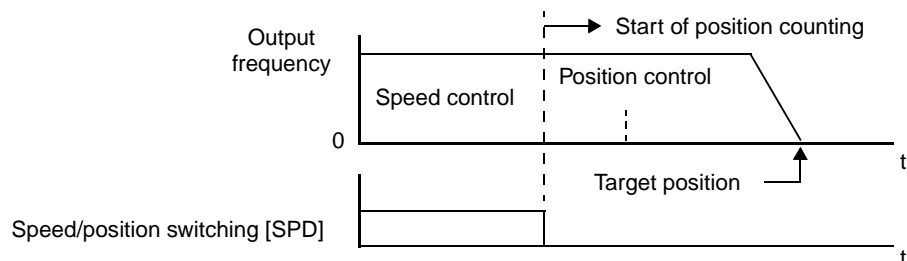

Pulse Counter Signals

Opt. Code and Symbol	74=[PCNT] 75=[PCC]
Valid for Inputs	[1] to [8]
Monitor Settings	D028
Default terminal	Requires config.

The intelligent pulse counter input [PCNT] allows you to input a pulse train up to 100 Hz via an intelligent input terminal. (For high-speed applications, use the encoder input expansion card instead.) Monitor the cumulative count with D028, pulse counter function. The value of the cumulative count cannot be stored in a separate register or parameter. The counter value is cleared to zero when inverter power is turn ON or the inverter is reset. You may also use the [PCC] Pulse Counter Clear input to clear the cumulative count.

The frequency resolution of the input pulse can be calculated by the formula shown below (assuming a pulse signal input with 50% duty cycle). Do not input higher frequencies than the calculated value.

Frequency resolution (Hz) = $250 / \text{input terminal response setting (C160 to C168) + 1}$
 Example: When the input terminal response time = 1, the frequency resolution = 125 Hz

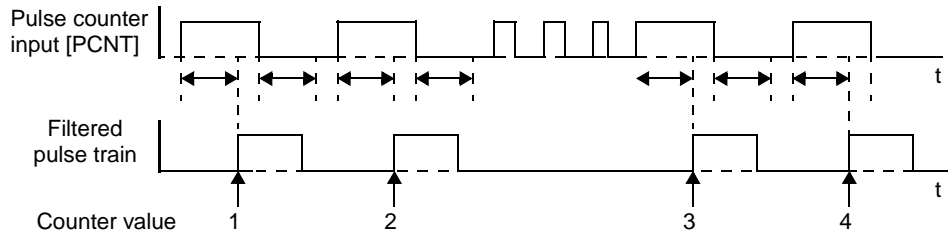

Using Intelligent Output Terminals

The intelligent output terminals are programmable in a similar way to the intelligent input terminals. The inverter has several output functions that you can assign individually to five physical logic outputs. Along with these solid-state outputs, the alarm relay output has type Form C (normally open and normally closed) contacts. The relay is assigned the alarm function by default, but you can assign it to any of the functions that the open-collector outputs can use.

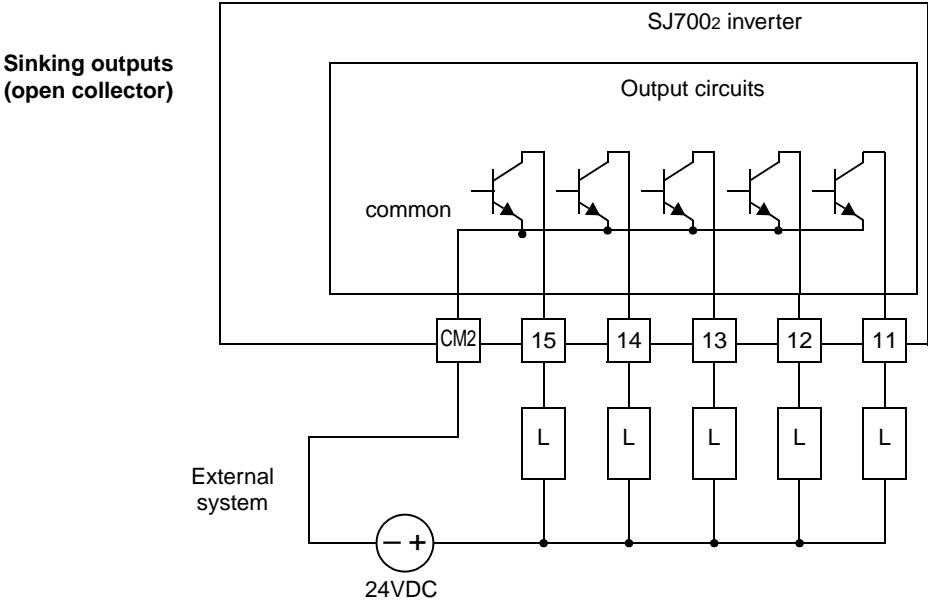

TIP: The open-collector transistor outputs can handle up to 50mA each. We highly recommend that you use an external power source as shown. It must be capable of providing at least 250mA to drive the outputs at full load.

If you need output current greater than 50mA, use the inverter output to drive a small relay. Be sure to use a diode across the coil of the relay as shown (reverse-biased) in order to suppress the turn-off spike, or use a solid-state relay.

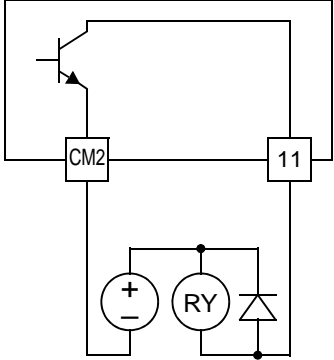

Operations and Monitoring

Run Signal

Opt. Code	00
Symbol	[RUN]
Valid for Outputs	[11 to [15], [ALx]
Required Settings	(none)
Default terminal	[12]

When the [RUN] signal is selected as an intelligent output terminal, the inverter outputs a signal on that terminal when it is in Run Mode. The output logic is active low, and is the open collector type (switch to common).

The timing diagram to the right shows the Run Signal operation in detail. The inverter outputs the [RUN] signal whenever the inverter output exceeds the start frequency specified by parameter B082. The start frequency is the initial inverter output frequency when it turns ON.

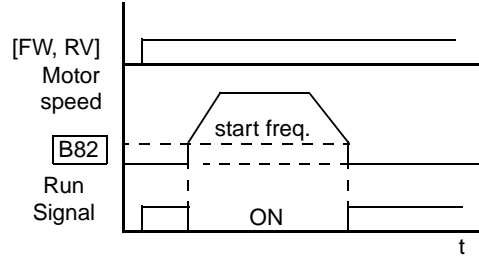

NOTE: If you use an intelligent output to drive an external relay, be sure to connect a diode across the relay coil. This will prevent the negative-going turn-off spike generated by the coil from damaging the inverter's output transistor.

Frequency Arrival Signals

The *Frequency Arrival* group of outputs help coordinate external systems with the current velocity profile of the inverter. As the name implies, output [FA1] turns ON when the output frequency arrives at the standard set frequency (parameter F001). Outputs [FA2] through [FA5] provide variations on this function for increased flexibility, relying on two programmable accel/decel thresholds. For example, you can have an output turn ON at one frequency during acceleration, and have it turn OFF at a different frequency during deceleration. All transitions have hysteresis to avoid output chatter if the output frequency is near one of the thresholds.

Opt. Code and Symbol	01=[FA1]
	02=[FA2]
	06=[FA3]
	24=[FA4]
	25=[FA5]
Valid for Outputs	[11 to [15], [ALx]
Required Settings	F001 for FA1
	C042 and C043 for FA2 and FA3
	C045 and C046 for FA4 and FA5
Default terminal	[11]=[FA1]
Other terminals	Requires config.

Symbol	Function Name	Description
FA1	Frequency arrival type 1 – constant speed	ON when output to motor is at the standard set frequency F001
FA2	Frequency arrival type 2 – over-frequency	ON when output to motor is at or above the FA threshold 1 (C042) during accel
FA3	Frequency arrival type 3 – at frequency	ON when output to motor is at the FA threshold 1 (C042) during accel, or at C043 during decel
FA4	Frequency arrival type 4 – over-frequency (2)	ON when output to motor is at or above the FA threshold 2 (C045) during accel
FA5	Frequency arrival type 5 – at frequency (2)	ON when output to motor is at the FA threshold 2 (C045) during accel, or at C046 during decel

Note the following:

- For most applications you will need to use only one or two of the frequency arrival type outputs (see example). However, it is possible to assign all five output terminals to output functions [FA1] through [FA5].
- For each frequency arrival threshold, the output anticipates the threshold (turns ON early) by an amount equal to 1% of the maximum frequency set for the inverter.
- The output turns OFF as the output frequency moves away from the threshold, delayed by an amount equal to 2% of the max. frequency.

Frequency arrival output [FA1] uses the standard output frequency (parameter F001) as the threshold for switching. In the figure to the right, the inverter accelerates to the set output frequency, which serves as the threshold for [FA1]. Parameters F_{on} and F_{off} illustrate the hysteresis that prevents output chatter near the threshold value.

- F_{on} is 1% of the max. output frequency
- F_{off} is 2% of the max. output frequency

The hysteresis effect causes the output to turn ON slightly *early* as the speed approaches the threshold. Then the turn-OFF point is slightly *delayed*. The 1% and 2% values also apply to the remaining Frequency arrival outputs, discussed below.

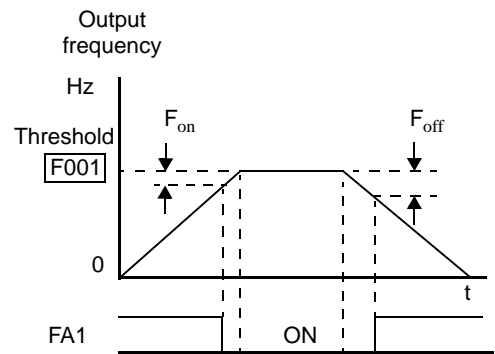

Frequency Arrival outputs [FA2] and [FA4] work the same way; they just use two separate threshold pairs as shown in the figure. These provide for separate acceleration and deceleration thresholds to provide more flexibility than for [FA1]. [FA2] uses C042 and C045 for ON and OFF thresholds, respectively. [FA4] uses C043 and C046 for ON and OFF thresholds, respectively. Having different accel and decel thresholds provides an asymmetrical output function. However, you can use equal ON and OFF thresholds, if desired.

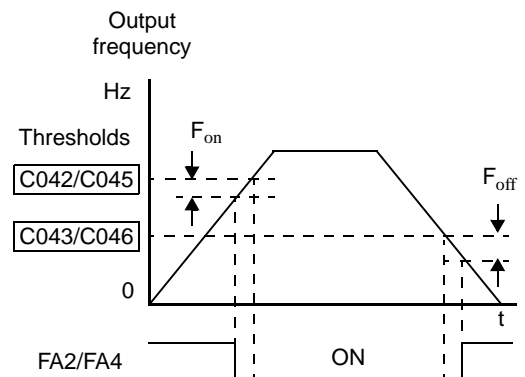

Frequency Arrival outputs [FA3] and [FA5] use the same threshold parameters as [FA2] and [FA4] above, but operate in a slightly different way. Refer to the diagram below. After the frequency arrives at the first threshold during acceleration and turns ON [FA3] or [FA5], they turn OFF again as the output frequency accelerates further. The second thresholds work similarly during deceleration. In this way, we have separate ON/OFF pulses for acceleration and deceleration.

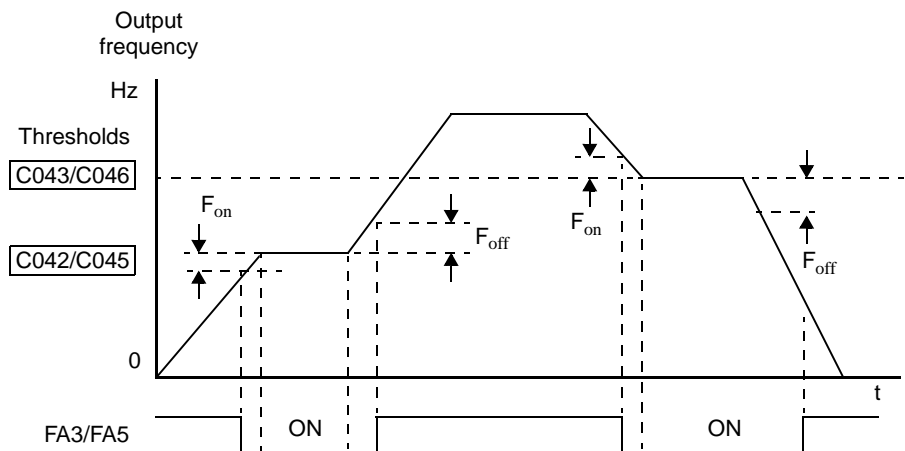

Operations and Monitoring

Overload Advance Notice Signal

Opt. Code and Symbol	03=[OL] 26=[OL2]
Valid for Outputs	[11 to [15], [ALx]
Required Settings	C041, C111
Default terminal	Requires config.

When the output current exceeds a preset value, the [OL] or [OL2] terminal signal turns ON. Parameter C041 sets the overload threshold for [OL]; parameter C111 sets it for [OL2]. The overload detection circuit operates during powered motor operation and during regenerative braking. The output circuits use open-collector transistors, and are active low.

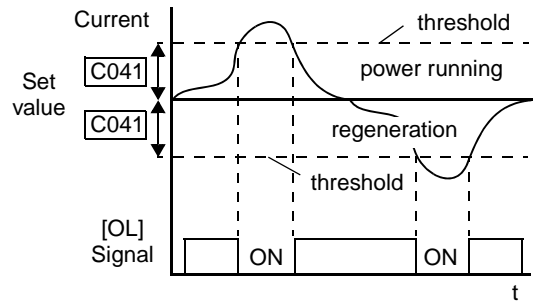

Symbol	Function Name	Description
OL	Overload advance notice signal (1)	ON when output current is more than the set threshold for the overload signal (C041)
OL2	Overload advance notice signal (2)	ON when output current is more than the set threshold for the overload signal (C111)

Note the following:

- The default threshold value is 100%. To change the level from the default, set C041 or C111(overload level).
- The accuracy of this function is the same as the function of the output current monitor on the [FM] terminal (see [“Analog Output Operation”](#) on page 4-66).



NOTE: If you use an intelligent output to drive an external relay, be sure to connect a diode across the relay coil. This will prevent the negative-going turn-off spike generated by the coil from damaging the inverter’s output transistor.

Output Deviation for PID Control

Opt. Code	04
Symbol	[OD]
Valid for Outputs	[11 to [15], [ALx]
Required Settings	C044
Default terminal	Requires config.

The PID loop error is defined as the magnitude (absolute value) of the difference between the Setpoint (target value) and the Process Variable (actual value). When the error magnitude exceeds the preset value for C044, the [OD] terminal signal turns ON. The default deviation value is set to 3%. To change this value, change parameter C044 (deviation level). Refer to [“PID Loop Operation”](#) on page 4-75.

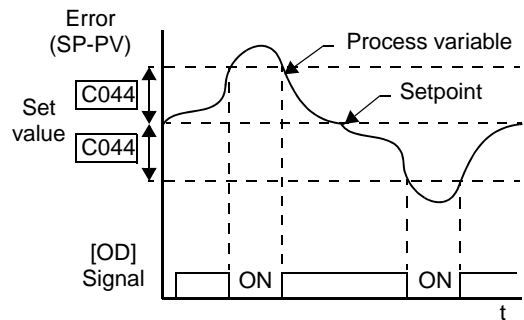

NOTE: If you use an intelligent output to drive an external relay, be sure to connect a diode across the relay coil. This will prevent the negative-going turn-off spike generated by the coil from damaging the inverter’s output transistor.

Alarm Signal

Opt. Code	05
Symbol	[AL]
Valid for Outputs	[11 to [15], [ALx]
Required Settings	C026, C036
Default terminals	Relay [AL0], [AL1], [AL2]

The inverter Alarm Signal is active when a fault has occurred and it is in the Trip Mode (refer to the diagram at right). When the fault is cleared the Alarm Signal becomes inactive.

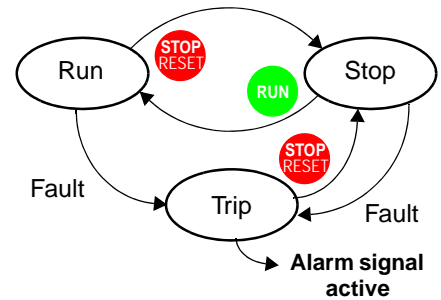

We must make a distinction between the Alarm Signal AL and the alarm relay contacts [AL0], [AL1] and [AL2]. The signal AL is a logic function, which you can assign to the open collector output terminals [11] to [15], or the relay outputs. The most common (and default) use of the relay is for AL, thus the labeling of its terminals. Use an open collector output (terminals [11] to [15]) for a low-current logic signal interface or to energize a small relay (50 mA maximum). Use the relay output to interface to higher voltage and current devices (10 mA minimum). Note the following:

- When the alarm output is set to normally closed, a time delay of less than 2 seconds occurs until the contact is closed when the power is turned ON.
- Terminals [11] – [15] are open collector outputs, so the electrical specifications of [AL] are different from the contact output terminals [AL0], [AL1], [AL2].
- When the inverter power supply is turned OFF, the alarm signal output is valid as long as the external control circuit has power.
- This signal output has the delay time (300ms nominal) from the fault alarm output.
- The relay contact specifications are in [“Specifications of Control and Logic Connections”](#) on page 4-9. The contact diagrams for different conditions are on the next page.

The alarm output terminals operate as shown below (left) by default. The contact logic can be inverted as shown (below right) by using the parameter setting C036. The relay contacts normally open (N.O.) and normally closed (N.O.) convention uses “normal” to mean the inverter has power and is in Run or Stop Mode. The relay contacts switch to the opposite position when it is in Trip Mode or when input power is OFF.

Contact position after initialization					Contact position inverted by C036 setting				
During normal running		When an alarm occurs or power is turned OFF			During normal running or power is turned OFF		When an alarm occurs		
Contact	Power	Run State	AL0-AL1	AL0-AL2	Contact	Power	Run State	AL0-AL1	AL0-AL2
N.C. (after initialize, C036=01)	ON	Normal	Closed	Open	N.O. (set C036=00)	ON	Normal	Open	Closed
	ON	Trip	Open	Closed		ON	Trip	Closed	Open
	OFF	–	Open	Closed		OFF	–	Open	Closed

Over-torque Signal

Opt. Code	07
Symbol	[OTQ]
Valid for Outputs	[11 to [15], [ALx]
Required Settings	C055, C056, C057, C058 A044 = 03 or 04 or 05
Default terminals	[14]

The Over-torque function [OTQ] turns ON when the estimated value of output torque of motor increases more than the arbitrary level set for the output (see table below). Recall that the torque limit function, covered in [“Torque Limit” on page 4-30](#), actually limits the torque during certain operating conditions. Instead, the over-torque output feature only monitors the torque, turning ON output [OTQ] if the torque is above programmable thresholds you set. The [OTQ] function is valid only for sensorless vector control, 0-Hz domain sensorless vector control, or vector control with sensor. Do not use the [OTQ] output except for these inverter operational modes.

Code	Function/Description	Data or Range
C055	Over-torque, forward-driving level setting	0 to 200%
C056	Over-torque, reverse-regenerating, level setting	0 to 200%
C057	Over-torque, reverse-driving, level setting	0 to 200%
C058	Over-torque, forward-regenerating, level setting	0 to 200%
C021 to C025	Intelligent output terminal [11] to [15] function	07

The assignment of the Over-torque function to an output terminal [OTQ] is detailed in the table at the left.

Instantaneous Power Failure / Under-voltage Signal

Opt. Code and Symbol	08=[IP]
	09=[UV]
Valid for Outputs	[11 to [15], [ALx]
Required Settings	B001, B002, B003, B004, B005, B007
Default terminals	Requires config.

An instantaneous power failure (complete loss) or under-voltage condition (partial loss) of inverter input voltage can occur without warning. SJ7002 Series inverters can be configured to respond to these conditions in different ways. You can select whether the inverter trips or retries (restart attempt) when an instantaneous power failure or under-voltage condition occurs. You can select the retry function with parameter B001.

Symbol	Function Name	Description
IP	Instantaneous Power Failure	ON when the inverter detects a loss of input power
UV	Under-voltage condition	ON when the inverter input power is less than the specified input range

When enabled, the Retry Function operates in the following ways:

Under-voltage conditions – When an instantaneous power failure or under-voltage condition occurs, the inverter will attempt to restart up to 16 times. A trip condition will occur on the 17th attempt, which must be cleared with the Stop/Reset key. When connecting control power supply terminals [Ro]–[To] to the DC bus [P]–[N], an under-voltage may be detected at power-off and cause a trip. If this is undesirable, set B004 to 00 or 02.

Over-current/voltage conditions – When retry function is selected and an over-current or an over-voltage condition occurs, a restart is attempted 3 times. A trip will occur on the 4th failed restart attempt. Use parameter B004 to select the trip and alarm response to instantaneous power failure and under-voltage conditions.

If an over-voltage or over-current trip occurs during the deceleration and an instantaneous power failure error (E16) is displayed the inverter goes into free-run stop. In this case make the deceleration time longer.

Use the parameters listed in the table below to define Instantaneous Power Failure and Under-voltage Signal operation.

Code	Function	Data or Range	Description
B001	Selection of automatic restart mode	00	Alarm output after trip, automatic restart disabled
		01	Restart at 0 Hz
		02	Retry with frequency matching to present motor speed
		03	Retry with frequency matching followed by deceleration to stop— then trip alarm
B002	Allowable under-voltage power failure time	0.3 to 1.0 sec.	The amount of time a power input under-voltage can occur without tripping the power failure alarm. If under-voltage exists longer than this time, the inverter trips, even if the restart mode is selected. If it exists less than this time retry will be attempted.
B003	Retry wait time before motor restart	0.3 to 100 sec.	Time delay after a trip condition goes away before the inverter restarts the motor
B004	Instantaneous power failure / voltage trip alarm enable	00	Disable
		01	Enable
		02	Disable during stop and ramp to stop
B005	Number of restarts on power failure / under-voltage trip events	00	Restart up to 16 times on instantaneous power failure or under-voltage
		01	Always restart on instantaneous power failure or an under-voltage condition
B007	Restart frequency threshold	0.00 to 400.0 Hz; model -4000HFx2 is 0.00 to 120.0 Hz	When frequency of the motor is less than this value, the inverter will restart at 0 Hz

Operations and Monitoring

In the following examples, t_0 = instantaneous power failure time, t_1 = allowable under-voltage / power failure time (B002), and t_2 = retry wait time (B003).

Example 1: Power failure within allowed limits; resume

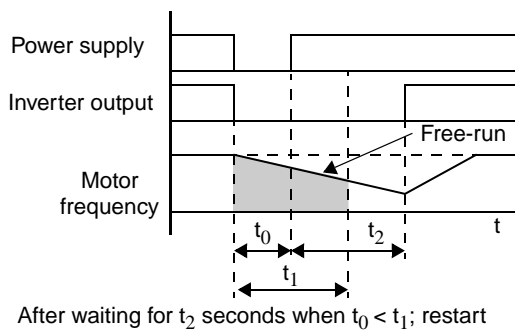

Example 2: Power failure longer than limits; trip

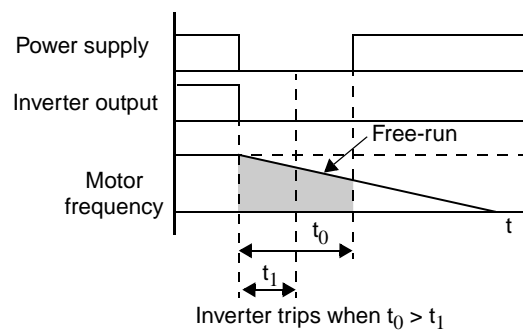

Examples 3 and 4 relate to configuring the inverter to retry upon power failure. Frequency matching is possible if the inverter frequency is greater than the B007 value. In this case, the inverter reads the motor RPM and direction. If this speed is higher than the matching setting (B007), the inverter waits until they are equal and then engages the output to drive the motor (example 3). If the actual motor speed is less than the restart frequency setting, the inverter waits for t_2 (value in B003) and restarts from 0 Hz (example 4). The display shows “0000” during an actual frequency matching event.

Example 3: Motor resumes via frequency-matching

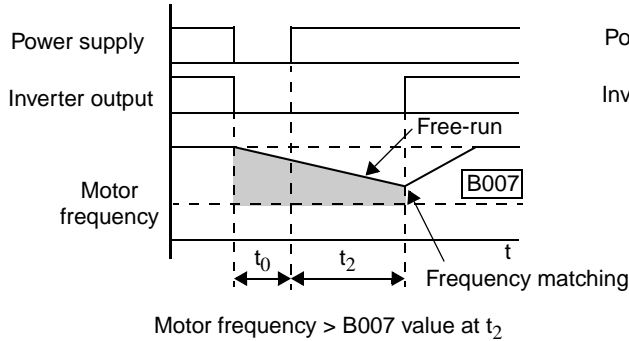

Example 4: Motor restarts from 0Hz

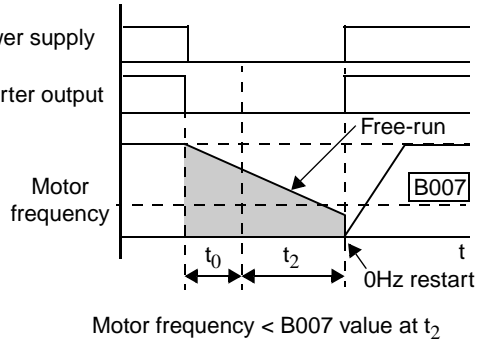

The Instantaneous Power Failure and Alarm output responses during various power loss conditions are shown in the diagram below. Use B004 to enable/disable the alarm output when instantaneous power failure or under-voltage occurs. The alarm output will continue while the control power of the inverter is present, even if the motor is stopped. Examples 5 to 7 correspond to normal wiring of the inverter’s control circuit. Examples 8 to 10 correspond to the wiring of the inverter’s control circuit for controlled deceleration after power loss (see [“Optional Controlled Decel and Alarm at Power Loss” on page 4-4](#)).

Instantaneous power failure operation with standard R0-T0 connections

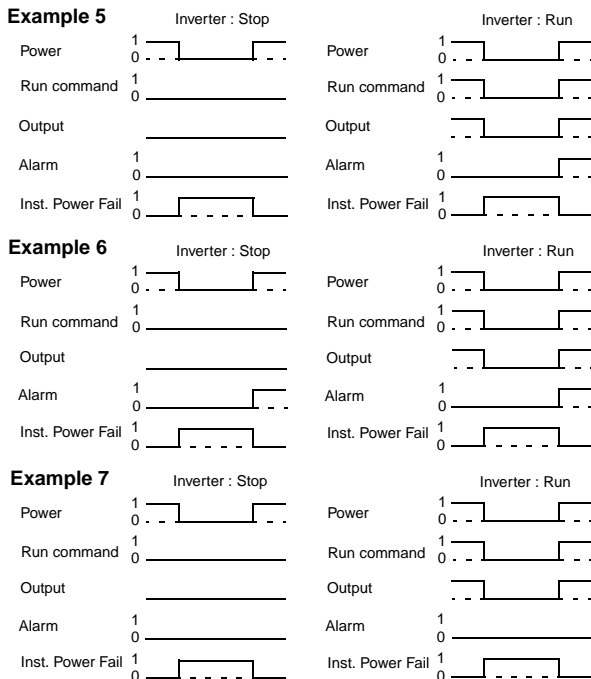

Instantaneous power failure operation with R0-T0 connected to P-N

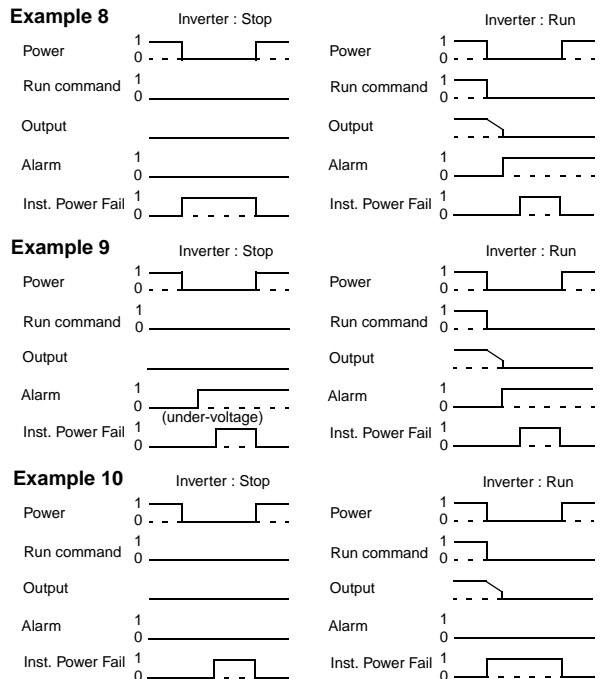

Torque Limit Signal

Opt. Code	10
Symbol	[TRQ]
Valid for Outputs	[11 to [15], [ALx]
Required Settings	B040... if B040=00 then set B041, B042, B043, B044
Default terminals	Requires config.

The Torque Limit output [TRQ] works in conjunction with the torque limit function covered in the intelligent input section. The torque limit function limits the motor torque according to the criteria selected by parameter B040. When torque limiting occurs, the [TRQ] output turns ON, then turns OFF automatically when the output torque falls below the specified limits. Note that the Torque Limit input [TL] must be ON in order to enable torque limiting and its related output, [TRQ]. See [“Torque Limit” on page 4-30](#) in the intelligent input section.

Run Time / Power-On Time Over Signals

Opt. Code and Symbol	11=[RNT]
	12=[ONT]
Valid for Outputs	[11 to [15], [ALx]
Required Settings	B034
Default terminals	Requires config.

SJ7002 Series inverters accumulate the total hours in Run Mode (run time) and the total hours of power-ON time. You can set thresholds for these accumulating timers. Once the threshold is exceeded, an output terminal will turn ON. One use of this is for preventative maintenance. A signal light or audible alert could signal the need for servicing, calibration, etc.

Symbol	Function Name	Description
RNT	Run Time Over	ON when the accumulated time spent in Run Mode exceeds the limit (B034)
ONT	Power-ON Time Over	ON when the accumulated power-ON time exceeds the limit (B034)

The two outputs [RNT] and [ONT] share the same time threshold parameter, B034. Typically, you will use either the [RNT] or the [ONT] output only—not both at once. These outputs are useful for the notification that a preventative maintenance interval has expired.

Thermal Warning Signal

Opt. Code	10
Symbol	[THM]
Valid for Outputs	[11 to [15], [ALx]
Required Settings	C061
Default terminals	Requires config.

The purpose of the electronic thermal setting is to protect the motor from overloading, overheating and being damaged. The setting is based on the rated motor current. The inverter calculates the thermal rise (heating) of the motor using the current output to the motor squared, integrated over the time spent at those levels. This feature allows the motor to draw excessive current for relatively short periods of time, allowing time for cooling.

The Thermal Warning output [THM] turns ON to provide a warning before the inverter trips for electronic thermal protection. You can set a unique thermal protection level for each of the three motor profiles, as shown in the table below.

Function Code	Function/Description	Data or Range	
B012 / B212 / B312	Electronic thermal setting (calculated within the inverter from current output)	Range is 0.2 * rated current to 1.2 * rated current	
B013 / B213 / B313	Electronic thermal characteristic (use the setting that matches your load)	00	Reduced torque
		01	Constant torque
		02	Free-setting

- The electronic thermal overload function uses the output current and time to calculate thermal heating of the motor. Use parameter C061 to set the threshold from 0 to 100% of trip level for turning ON the intelligent output [THM] at that level.
- The thermistor input of the inverter is a separate function from the electronic thermal function. It has its own threshold to cause a trip alarm at a particular thermistor resistance.

For example, suppose you have inverter model SJ700-110LFE2. The rated motor current is 46A. The setting range is (0.2 * 46) to (1.2 * 46), or 9.2A to 55.2A. For a setting of B012=46A (current at 100%), the figure to the right shows the curve.

The electronic thermal characteristic adjusts the way the inverter calculates thermal heating, based on the type of torque control the inverter uses.

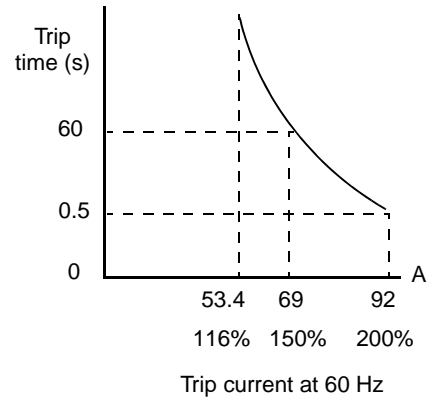

CAUTION: When the motor runs at lower speeds, the cooling effect of the motor's internal fan decreases.

Reduced Torque Characteristic – The example below shows the effect of the reduced torque characteristic curve (for example motor and current rating). At 20Hz, the output current is reduced by a factor of 0.8 for given trip times.

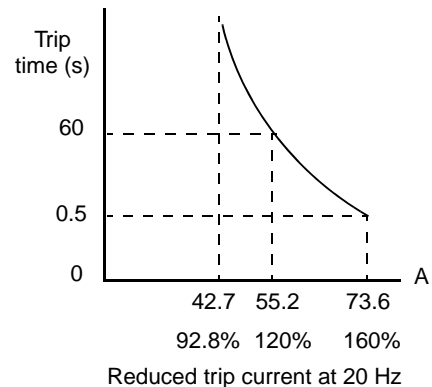
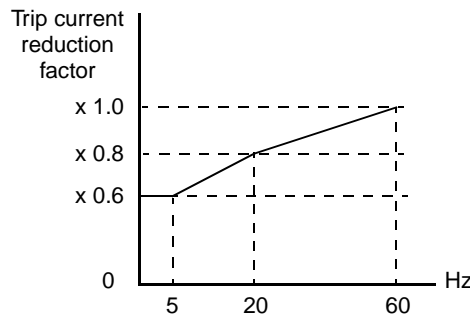

Constant Torque Characteristic – Selecting the constant torque characteristic for the example motor gives the curves below. At 2.5 Hz, the output current is reduced by a factor of 0.9 for given trip times.

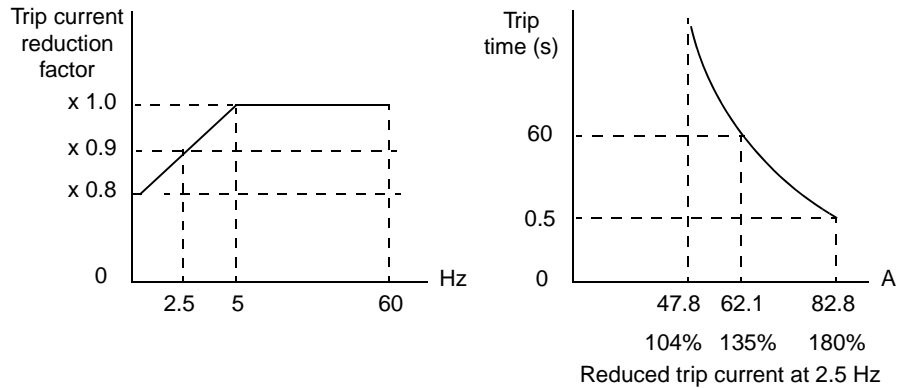

Free Thermal Characteristic - It is possible to set the electronic thermal characteristic using a free-form curve defined by three data points, according to the table below.

Function Code	Name	Description	Range
B015 / B017 / B019	Free-setting electronic thermal frequency 1, 2, 3	Data point coordinates for Hz axis (horizontal) in the free-form curve	0 to 400Hz
B016 / B018 / B020	Free setting electronic thermal current 1, 2, 3	Data point coordinates for Ampere axis (vertical) in the free-form curve	0.0 = (disable) 0.1 to 1000.

The left graph below shows the region for possible free-setting curves. The right graph below shows an example curve defined by three data points specified by B015 – B020.

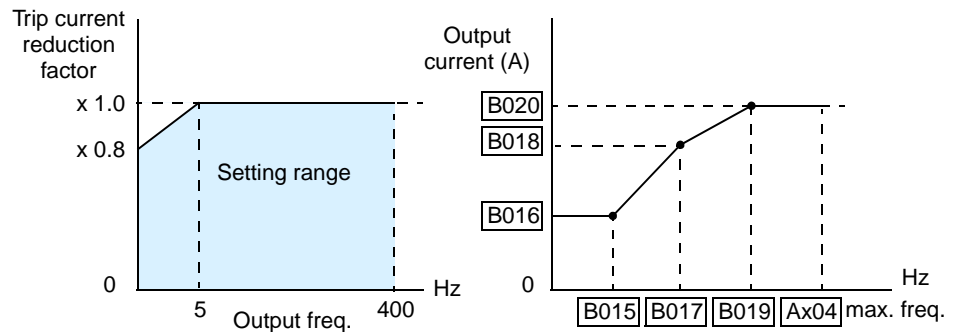

Suppose the electronic thermal setting (B012) is set to 44 Amperes. The graph below shows the effect of the free setting torque characteristic curve. For example, at (B017) Hz, the output current level to cause overheating in a fixed time period is reduced to (B018) A. Points (x), (y), and (z) show the adjusted trip current levels in those conditions for given trip times.

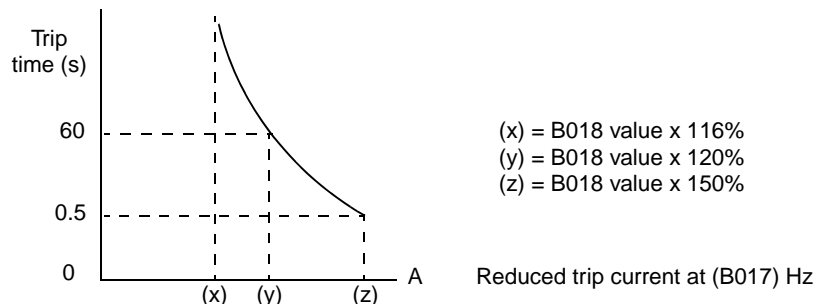

Brake Control Signals

Opt. Code and Symbol	19=[BRK] 20=[BER]
Valid for Outputs	[11 to [15], [ALx]
Required Settings	B120, B121, B122, B123, B124, B125, B126
Default terminals	Requires config.

The Brake Control function enables the inverter to control external braking systems with a particular safety characteristic. The brake release logic convention is such that an open circuit fault (such as loose wire) causes the external brake to engage. A complete discussion of the operation of brake control is in [“External Brake Control Function” on page 4-32](#). The diagram below shows the signals that are important to the External Brake Control function.

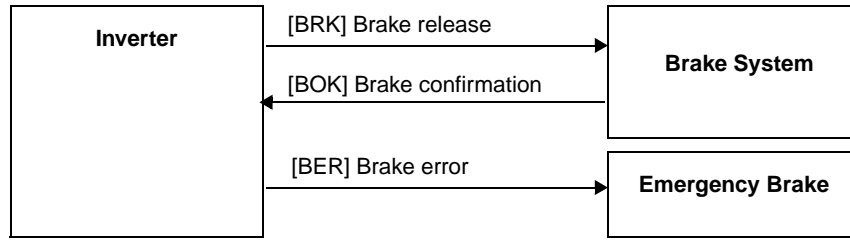

Symbol	Function Name	Input State	Description
BRK	Brake Release	ON	when the inverter signals the external brake system to release (open) its brake
		OFF	when the inverter is not driving the motor, and needs the external brake engaged
BER	Brake Error	ON	when the output current is less than the set releasing current
		OFF	when the brake function is not in use, or when the output current to the motor is correct and it is safe to release the brake

Expansion Card Output Signals

Other outputs listed below require expansion card SJ-FB Encoder Feedback board. Please see the SJ-FB manual for more information.

Opt. Code and Symbol	21=[ZS] 22=[DSE] 23=[POK]
Valid for Outputs	[11 to [15], [ALx]
Required Settings	C061
Default terminals	Requires config.

Opt. Code	Symbol	Function Name	Description
21	ZS	Zero Speed Detect signal	Signal indicates the encoder pulses of the motor have stopped
22	DSE	Speed Deviation Excessive	Velocity error exceeds the error threshold defined by parameter P026
23	POK	Positioning Completion	Indicates the load position is at the target

Operations and Monitoring

Analog Disconnect Detection

Opt. Code and Symbol	27=[Odc]
	28=[OI _{dc}]
	29=[O2 _{dc}]
Valid for Outputs	[11 to [15], [ALx]
Required Settings	B070, B071, B072
Default terminal	Requires config.

The analog disconnect detection is useful when the inverter receives a speed reference from an external device. Upon input signal loss at either the [O], [OI], or [O2] terminal, the inverter normally just decelerates the motor to a stop. However, the inverter can use the intelligent output terminals [O_{dc}], [OI_{dc}], or [O2_{dc}] to signal other machinery that a signal loss has occurred.

Each analog disconnect output has independent thresholds, set by B070, B071, and B072. When the input is below the set threshold value, the inverter substitutes the threshold value for the input. Related parameters are given in the following tables.

Opt. Code	Symbol	Function Name
27	O _{dc}	Analog [O] disconnect detect
28	OI _{dc}	Analog [OI] disconnect detect
29	O2 _{dc}	Analog [O2] disconnect detect

Code	Function	Data or Range	Description
B070	[O] input disconnect threshold	0 to 100%	If [O] value < B070, turn ON [O _{dc}]; substitute B070 value for [O] input
		no (255)	Ignore B070 setting
B071	[OI] input disconnect threshold	0 to 100%	If [OI] value < B071, turn ON [O _{dc}]; substitute B071 value for [OI] input
		no (255)	Ignore B071 setting
B072	[O2] input disconnect threshold	0 to 100%	If [O2] value < B072, turn ON [O _{dc}]; substitute B072 value for [O2] input
		no (255)	Ignore B072 setting

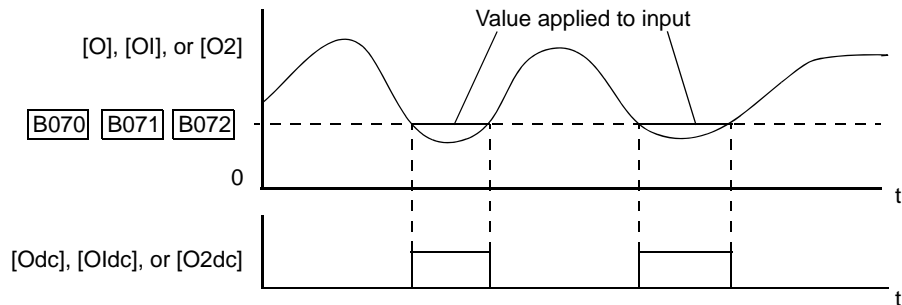

The inverter can also detect when an analog input value is within a range (or *window*) of values. See [“Window Comparator Signals” on page 4-62](#).

Operations and Monitoring

PID Feedback Second Stage Output

Opt. Code	31
Symbol	[FBV]
Valid for Outputs	[11 to [15], [ALx]
Required Settings	C052, C053
Monitor Settings	D004
Default terminals	Requires config.

The inverter has a built-in PID loop feature for two-stage control, useful for certain applications such as building ventilation or heating and cooling (HVAC). In an ideal control environment, a single PID loop controller (stage) would be adequate. However, in certain conditions, the maximum output energy from the first stage is not enough to maintain the Process Variable (PV) at or near the Setpoint (SP). And, the output of the first stage is in saturation. A simple solution is to add a second stage, which puts an additional and constant amount of energy into the system under control. When sized properly, the boost from the second stage brings the PV toward the desired range, allowing the first stage PID control to return to its linear range of operation.

The two-stage method of control has some advantages for particular applications.

- The second stage is only ON in adverse conditions, so there is an energy savings during normal conditions.
- Since the second stage is simple ON/OFF control, it is less expensive to add than just duplicating the first stage.
- At powerup, the boost provided by the second stage helps the process variable reach the desired setpoint sooner than it would if the first stage acted alone.
- Even though the second stage is simple ON/OFF control, when it is an inverter you can still adjust the output frequency to vary the boost it provides.

Refer to the example diagram below. Its two stages of control are defined as follows:

- Stage 1 - Inverter #1 operating in PID loop mode, with motor driving a fan
- Stage 2 - Inverter #2 operating as an ON/OFF controller, with motor driving a fan

Stage #1 provides the ventilation needs in a building most of the time. On some days, there is a change in the building's air volume because large warehouse doors are open. In that situation, Stage #1 alone cannot maintain the desired air flow (PV sags under SP). Inverter #1 senses the low PV and its PID Second Stage Output at [FBV] terminal turns ON. This gives a Run FWD command to Inverter #2 to provide the additional air flow.

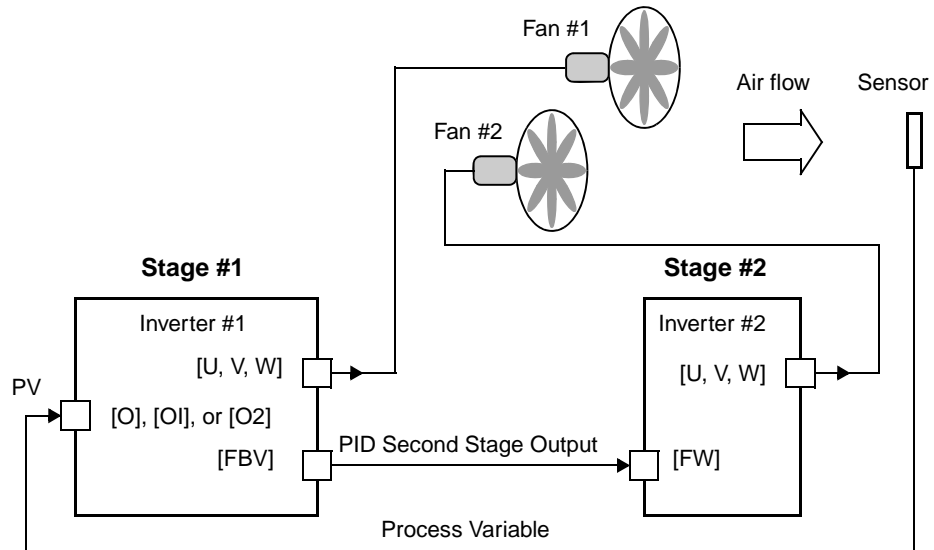

NOTE: The [FBV] is designed for implementing two-stage control. The PV high limit and PV low limit parameters, C052 and C053, do not function as process alarm thresholds. Terminal [FBV] does not provide a PID alarm function.

To use the PID Second Stage Output feature, you will need to choose upper and lower limits for the PV, via C053 and C052 respectively. As the timing diagram below shows, these are the thresholds Stage #1 inverter uses to turn ON or OFF Stage #2 inverter via the [FBV] output. The vertical axis units are percent (%) for the PID setpoint, and for the upper and lower limits. The output frequency, in Hz, is superimposed onto the same diagram.

When system control begins, the following events occur (in sequence in the timing diagram):

1. Stage #1 inverter turns ON via the [FW] Run command.
2. Stage #1 inverter turns ON the [FBV] output, because the PV is below the PV low limit C053. So, Stage #2 is assisting in loop error correction from the beginning.
3. The PV rises and eventually exceeds the PV high limit C052. Stage #1 inverter then turns OFF the [FBV] output to Stage #2, since the boost is no longer needed.
4. When the PV begins decreasing, only Stage #1 is operating, and it is in the linear control range. This region is where a properly configured system will operate most often.
5. The PV continues to decrease until it crosses under the PV low limit (apparent external process disturbance). Stage #1 inverter turns ON the [FBV] output, and Stage #2 inverter is assisting again.
6. After the PV rises above the PV low limit, the [FW] Run command to Stage #1 inverter turns OFF (as in a system shutdown).
7. Stage #1 inverter enters Stop Mode and automatically turns OFF the [FBV] output, which causes Stage #2 inverter to also stop.

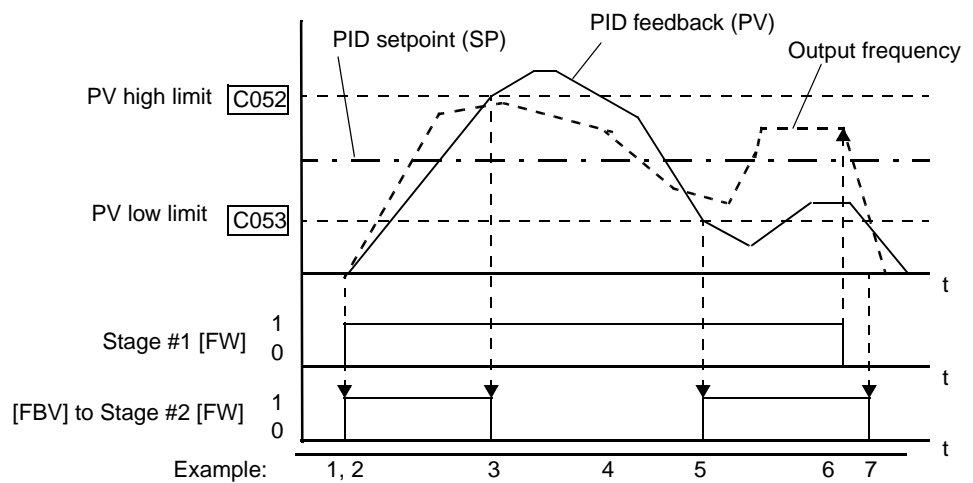

Operations and Monitoring

Network Detection Signal

Opt. Code	32
Symbol	[Ndc]
Valid for Outputs	[11 to [15], [ALx]
Required Settings	C076, C077
Default terminals	Requires config.

The intelligent output [Ndc] Network Detection Signal indicates the status of ModBus-RTU communications (not ASCII protocol). The [Ndc] terminal turns ON when the external device on the ModBus stops transmitting for a time that exceeds parameter C077, Communication Time-out Before Trip. If a time-out occurs, the output [Ndc] remains ON until ModBus-RTU communication resumes. Use parameter C076 Action Upon Communication Error Selection to select the desired inverter response to a time-out event.

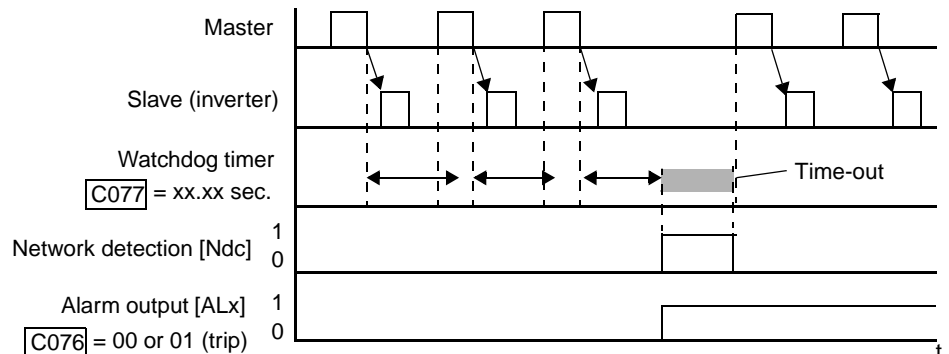

Logic Output Signals

Opt. Code and Symbol	33=[LOG1]
	34=[LOG2]
	35=[LOG3]
	36=[LOG4]
	37=[LOG5]
38=[LOG6]	
Valid for Outputs	[11 to [15], [ALx]
Required Settings	C142 to C159
Default terminal	Requires config.

The Logic Output Function uses the inverter’s built-in logic feature. You can select any two of the other intelligent output options for use as internal inputs to the logic function. You may also select from three logical operators AND, OR, or XOR (exclusive OR), to be applied to the two inputs. A total of six outputs are available, shown in the following tables.

Symbol	Option Code	Function	A Input	B Input	Logical Operator
LOG1	33	Logic Output 1	C142	C143	C144
LOG2	34	Logic Output 2	C145	C146	C147
LOG3	35	Logic Output 3	C148	C149	C150
LOG4	36	Logic Output 4	C151	C152	C153
LOG5	37	Logic Output 5	C154	C155	C156
LOG6	38	Logic Output 6	C157	C158	C159

The example below shows a configuration for [LOG1] Logic Output 1. Parameters C142 and C143 contain option codes for two outputs we select to be used as inputs to the logic operation. Parameter C144 contains the select code for the logic operation. 00=AND, 01=OR, and 02=XOR.

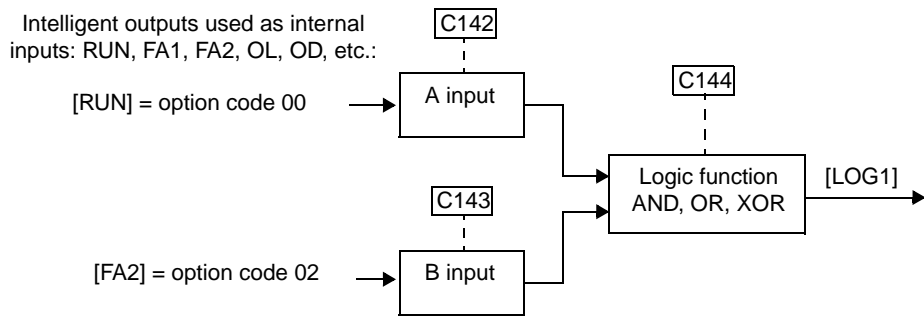

Input States		[LOGx] Output State		
A Input	B Input	AND (00)	OR (01)	XOR (02)
0	0	0	0	0
0	1	0	1	1
1	0	0	1	1
1	1	1	1	0

Capacitor Life Warning

Opt. Code	39
Symbol	[WAC]
Valid for Outputs	[11 to [15], [ALx]
Monitor Settings	D022
Default terminals	Requires config.

The inverter calculates the capacitor life remaining based on the internal temperature of the inverter and the cumulative power-ON time. The [WAC] Capacitor Life Warning output turns ON to indicate that the capacitors have reached end-of-life. If this event occurs, Hitachi recommends that you replace the main circuit board and logic circuit board. You may also use monitor parameter D022 at the digital operator to monitor the status of capacitor life.

Low Cooling Fan Speed

Opt. Code	40
Symbol	[WAF]
Valid for Outputs	[11 to [15], [ALx]
Required Settings	B092
Monitor Settings	D022
Default terminals	Requires config.

The inverter monitors the heat sink cooling fan speed to help prevent overheating. If the speed of the fan(s) decreases to 75% or less of full speed, output [WAF] Low Cooling Fan Speed turns ON. Note that if you set parameter B092 Cooling Fan Control = 01 (Fan ON only during RUN), the inverter will not output the [WAF] signal when the cooling fan is stopped.

If the [WAF] signal turns ON during operation, first check the cooling fan inlet for clogging by dust and debris. If the air circulation path is clear, the fans may need replacement. You may also use monitor parameter D022 at the digital operator to monitor the status of fan speed.

Starting Contact Signal

Opt. Code	41
Symbol	[FR]
Valid for Outputs	[11 to [15], [ALx]
Required Settings	none
Default terminals	Requires config.

The inverter generates [FR] Starting Contact Signal to correspond with Run (FW or RV) input commands. The source of the Run command does not matter (so the A002 setting is ignored). If both FW and RV inputs are ON, the inverter stops motor operation and turns OFF the [FR] output. The [FR] signal is useful for external devices that need a traditional starting contact signal to coordinate operation with the inverter.

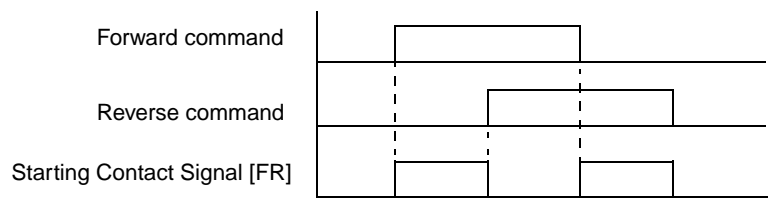

Heatsink Overheat Warning

Opt. Code	42
Symbol	[OHF]
Valid for Outputs	[11 to [15], [ALx]
Required Settings	C064
Default terminals	Requires config.

The inverter monitors its heatsink temperature to detect overheating. You can use parameter C064, Heatsink Overheat Warning Level, to set the over-temperature threshold for the heatsink in degrees C. The inverter will turn ON intelligent output [OHF] Heatsink Overheat Warning if the heatsink temperature exceeds the value in parameter C064.

Low Output Current Signal

The inverter monitors the output current to the motor according to parameter C038, Low Current Indication Output Mode Select. Use parameter C039, Low Current Indication Detection Level, to set the low-current threshold. The Low Output Current Signal [LOC] will turn ON if the output current is less than the C038 threshold and motor operation corresponds to the selected monitoring mode.

Opt. Code	43
Symbol	[LOC]
Valid for Outputs	[11 to [15], [ALx]
Required Settings	C038, C039
Default terminals	Requires config.

Code	Function	Data or Range	Description
C038	Low current indication output mode select	00	Output during acceleration/deceleration and constant speed operation
		01	Output only during constant speed *1
C039	Low current indication detection level	0.0 to 2.0 x rated inverter current	Low current threshold, used for intelligent output [LOC]

Note 1: Note that when parameter A001 Frequency Source Setting = 01 (control terminal), it is possible that the inverter may not recognize a constant speed due to sampling. In this case, change C038 = 00 to include accel./decel., or increase the analog input filter A016 setting.

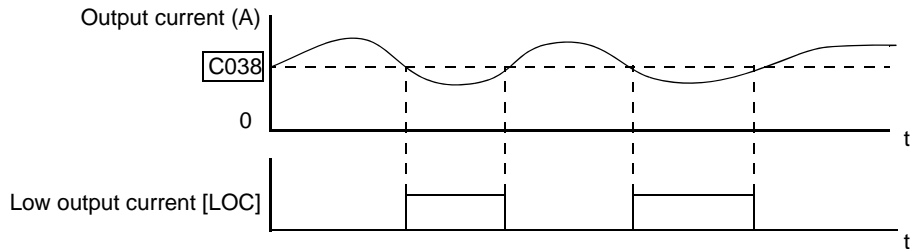

General Output Signals

Refer to the Easy Sequence Instruction Manual for information on how to configure and use the general purpose outputs MO1 to MO6.

Opt. Code and Symbol	44=[MO1]
	45=[MO2]
	46=[MO3]
	47=[MO4]
	48=[MO5]
	49=[MO6]
Valid for Outputs	[11 to [15], [ALx]
Required Settings	See Easy Sequence
Default terminal	Requires config.

Inverter Ready Signal

Opt. Code	50
Symbol	[IRDY]
Valid for Outputs	[11 to [15], [ALx]
Required Settings	none
Default terminals	Requires config.

The inverter turns ON the Inverter Ready Signal [IRDY] output when it is ready to receive an operation command such as Run Forward, Run Reverse, or Jog. Otherwise, [IRDY] will be OFF and the inverter cannot accept operation commands. If [IRDY] is OFF, then check the input power supply voltage at the [R], [S], and [T] terminals to be sure the voltage is within the input specification range. The [IRDY] output is OFF when the input power is provided only to the control power supply,

Forward/Reverse Rotation Signals

Opt. Code and Symbol	51=[FWR]
	52=[RVR]
Valid for Outputs	[11 to [15], [ALx]
Required Settings	none
Default terminal	Requires config.

The Forward Rotation Signal [FWR] is ON only when the inverter is driving the motor in the *forward* direction. Similarly, the Reverse Rotation Signal [RVR] is ON only when the inverter is driving the motor in the *reverse* direction. Both signals are OFF when the motor is stopped.

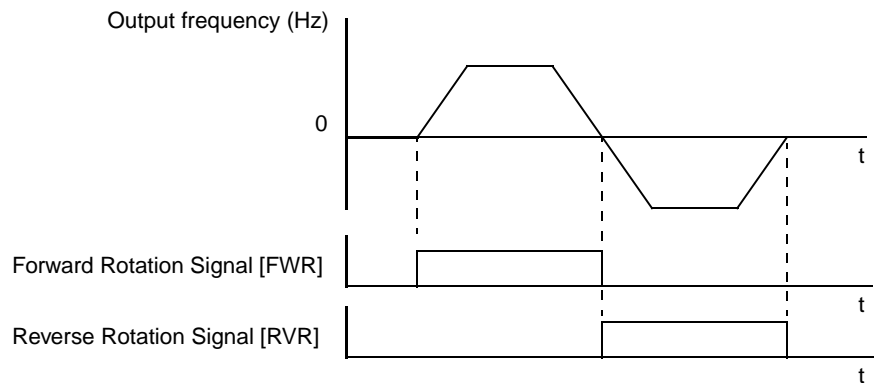

Major Failure Signal

Opt. Code	53
Symbol	[MJA]
Valid for Outputs	[11 to [15], [ALx]
Required Settings	none
Default terminals	Requires config.

The Major Failure Signal [MJA] indicates that a particular type of error event has occurred, resulting in an inverter trip. In addition to causing the normal trip alarm, the following error events also will turn ON the [MJA] output, when assigned to an intelligent output terminal.

Error Code	Name
E10	CT (current transformer) error
E11	CPU error
E14	Ground fault
E20	Inverter thermal trip with low fan speed
E23	Gate array error
E25	Main circuit error

Window Comparator Signals

Opt. Code and Symbol	54=[WCO]
	55=[WCOI]
	56=[WCO2]
Valid for Outputs	[11 to [15], [ALx]
Required Settings	none
Default terminal	Requires config.

The window comparator function outputs turn ON when You can also monitor each analog input by comparing it to a threshold value. This feature allows the inverter to detect disconnected signal wiring, loss of power at a signal transmitter, etc. When the input is below the set threshold value, the inverter substitutes the threshold value for the input. The related parameters are given in the following tables.

Opt. Code	Symbol	Function Name
54	WCO	[O] terminal window comparator
55	WCOI	[OI] terminal window comparator
56	WCO2	[O2] terminal window comparator

Code	Function	Range	Description
B060	[O] input maximum limit level of window comparator	0. to 100. (%)	Lower limit = B061 + B062 x 2
B061	[O] input minimum limit level of window comparator	0. to 100. (%)	Lower limit = B060 - B062 x 2
B062	[O] input hysteresis width of window comparator	0. to 10. (%)	Lower limit = B061 - B062 x 2
B063	[OI] input maximum limit level of window comparator	0. to 100. (%)	Lower limit = B064 + B066 x 2
B064	[OI] input minimum limit level of window comparator	0. to 100. (%)	Lower limit = B063 - B066 x 2
B065	[OI] input hysteresis width of window comparator	0. to 10. (%)	Lower limit = B063 - B064 x 2
B066	[O2] input maximum limit level of window comparator	-100. to 100. (%)	Lower limit = B067 + B068 x 2
B067	[O2] input minimum limit level of window comparator	-100. to 100. (%)	Lower limit = B066 - B068 x 2
B068	[O2] input hysteresis width of window comparator	0. to 10. (%)	Lower limit = B066 - B067 x 2

The following signal diagram shows the window comparator output generated from input signals and comparator settings listed along the Y axis.

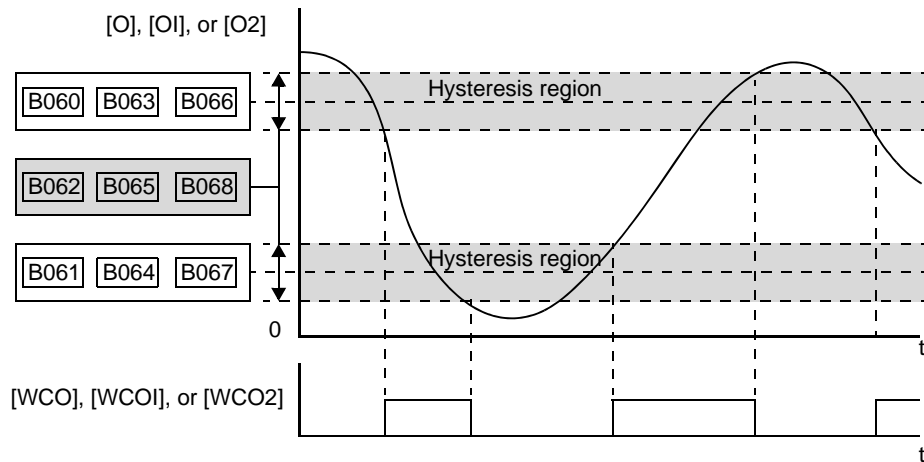

Operations and Monitoring

Analog Input Operation

Input Terminal Signals

SJ7002 inverters provide for an external analog input to command the inverter frequency output value. The analog input terminal group includes the [L], [OI], [O], [O2], and [H] terminals on the control connector, which provide for Voltage [O] and [O2] or Current [OI] input. All analog input signals must use the analog ground [L].

If you use either the voltage or current analog input, you must select one of them using the logic input terminal function [AT] analog type. If terminal [AT] is OFF, the voltage input [O] can command the inverter output frequency. If terminal [AT] is ON, the current input [OI] can command the inverter output frequency. The [AT] terminal function is covered in [“Analog Input Current/Voltage Select” on page 4-24](#). Remember that you must also set A001 = 01 to select analog input as the frequency source.

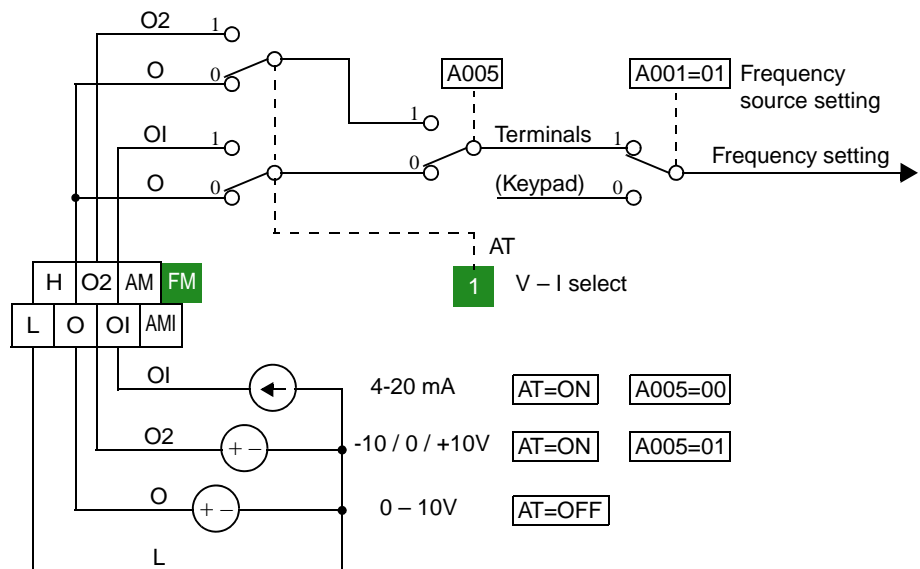
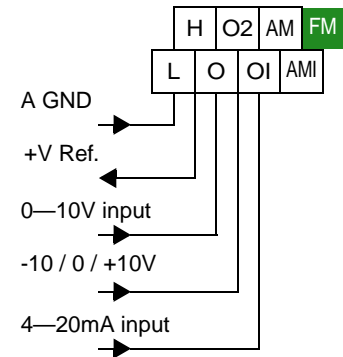

Operations and Monitoring

Input Filter

Parameter A016 adjusts an analog input sampling filter that evenly affects all analog inputs shown above. The parameter range is from 1 to 30. Before increasing the filter setting, we recommend trying to find the cause of input analog noise. Check for the following:

- Look for nearby high-current wiring—avoid any parallel runs to the analog signal wires
- Check the impedance between the chassis grounds of the inverter and the analog signal source equipment—a good connection will have a low impedance
- Check the analog signal ground impedance from the inverter to the analog signal source
- Avoid ground loops... measure the current (or voltage drop) on the chassis ground and signal ground connections; the ideal value is zero

After taking steps to minimize the analog signal noise sources, increase the filter time constant (A016) until the motor output frequency (when commanded by analog inputs) becomes stable.

The following tables show the available analog input settings. Parameters A006, A005, and input terminal [AT] determine the External Frequency Command input terminals that are available and how they function. The Trim Frequency input [O2]—[L] is available (when check marked) for some settings. Other settings make the reverse direction (in addition to forward) available for bipolar input settings (when check marked). A bipolar input responds to positive input voltages with a forward motor rotation, and to negative input voltages with reverse motor rotation.

A006	A005	[AT]	External Frequency Command Input	Trim Frequency Command Input	Reverse avail. (bipolar input)
00 OR 03	00	OFF	[O]	✗	✗
		ON	[OI]	✗	✗
	01	OFF	[O]	✗	✗
		ON	[O2]	✗	✓
01	00 Example 1	OFF	[O]	[O2]	✗
		ON	[OI]	[O2]	✗
	01	OFF	[O]	[O2]	✗
		ON	[O2]	✗	✓
02	00 Example 2	OFF	[O]	[O2]	✓
		ON	[OI]	[O2]	✓
	01	OFF	[O]	[O2]	✓
		ON	[O2]	✗	✓
—	02	OFF	[O]	[O2]	✗
		ON	Keypad pot.	[O2]	✗
	03	OFF	[OI]	[O2]	✗
		ON	Keypad pot.	[O2]	✗
	04	OFF	[O2]	✗	✓
		ON	Keypad pot.	[O2]	✗

The table below applies when the [AT] input function is not assigned to *any* intelligent input terminal. The A005 setting, normally used in conjunction with an [AT] input, is ignored.

A006	A005	[AT]	External Frequency Command Input	Trim Frequency Command Input	Reverse avail. (bipolar input)
00	—	(not assigned to any input terminal)	[O2]	✗	✓
01	—		Summation of [O] and [OI]	[O2]	✗
02	—		Summation of [O] and [OI]	[O2]	✓
03	—		Summation of [O] and [OI]	✗	✗



CAUTION: Whenever the [AT] input function is *not* assigned to any input terminal and reverse rotation is not desired or is unsafe, be sure to set A006 = 01. This setting makes the [O2] input unipolar only.

The examples below show how the use of the [AT] input during operation enables/disables the Trim Frequency Command input [O2]—[L]. The [O2]—[L] input may be used alone, or as an offset control for the primary analog input.

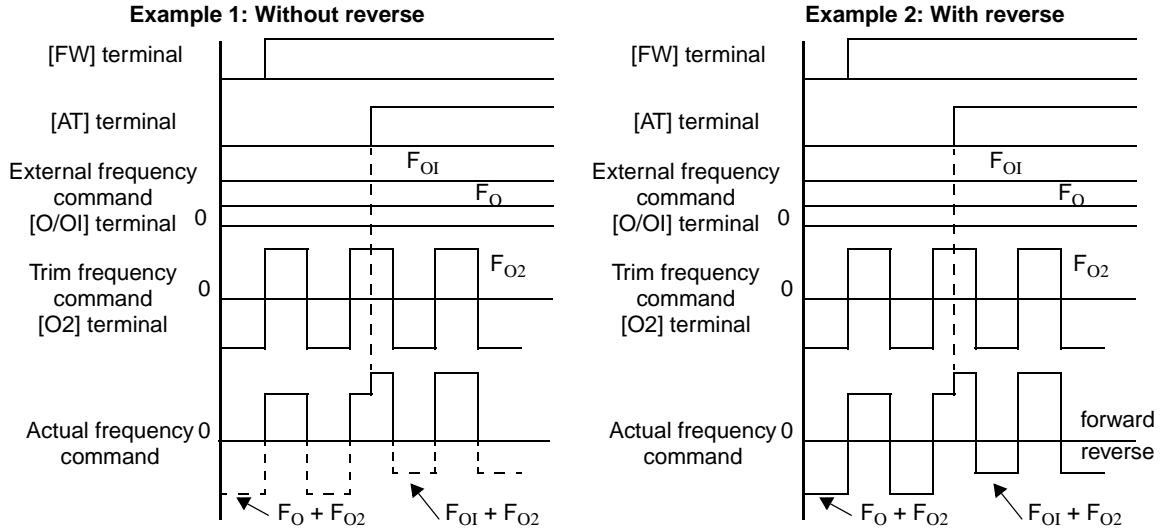

Wiring Examples

Using an external potentiometer is a common way to control the inverter output frequency (and a good way to learn how to use the analog inputs). The potentiometer uses the built-in 10V reference [H] and the analog ground [L] for excitation, and the voltage input [O] for the signal. By default, the [AT] terminal selects the voltage input when it is OFF. Take care to use the proper resistance for the potentiometer, which is 1 to 2kΩ, 2 Watts.

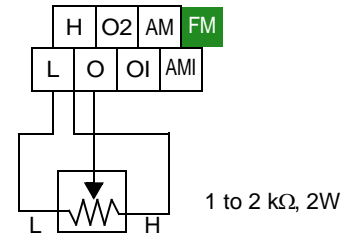

Voltage Input – The 0–10V voltage input circuit uses terminals [L] and [O]. Attach the signal cable’s shield wire to terminal [L] on the inverter only. DO NOT ground the shield at its other end. Maintain the voltage within specifications (do not apply negative voltage). Normally a full-span input level (10V) will give the maximum motor frequency. You can use parameter A014 to select a lower voltage for full output frequency (such as using a 5V input signal).

Bipolar Voltage Input – The -10 / 0 / +10V voltage input circuit uses terminals [L] and [O2]. Attach the cable’s shield wire to terminal [L] on the inverter only. Maintain the voltage within specifications. Only apply a negative voltage if this input is configured for bipolar use.

Current Input – The current input circuit uses terminals [OI] and [L]. The current comes from a *sourcing* type transmitter; a *sinking* type will not work! This means the current must flow into terminal [OI], and terminal [L] is the return back to the transmitter. The input impedance from [OI] to [L] is 250 Ohms. Attach the cable’s shield wire to terminal [L] on the inverter only.

Standard Voltage Input

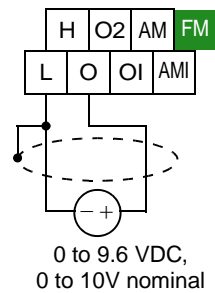

Bipolar Voltage Input

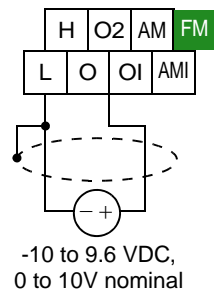

Current Input

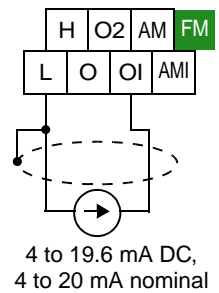

See I/O specs on page 4-9.

Operations and Monitoring

Analog Output Operation

In the system design for inverter applications it is sometimes useful to monitor inverter operation from a remote location. In some cases, this requires only a panel-mounted analog meter (moving-coil type). In other cases, a controller device such as a PLC may monitor and command the inverter frequency and other functions. The inverter can transmit the (real-time) output frequency, current, torque, or other parameters to the controller to confirm actual operation. The monitor output terminal [FM] serves these purposes.

[FM] Terminal

The inverter provides an analog/digital output on terminal [FM] (frequency monitor). It uses terminal [CM1] as digital GND reference. While many applications use this terminal to monitor the output frequency, you can configure terminal [FM] to transmit one of several parameters. Most use *pulse-width modulation* (PWM) to represent the value, while one parameter uses *frequency modulation* (FM) to represent the value. Do not confuse the notation for terminal [FM] (with brackets) with FM signal type.

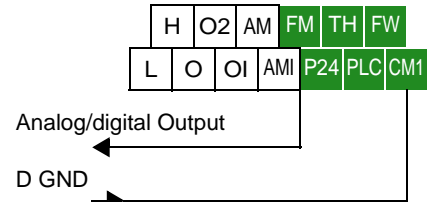

See I/O specs on page 4-9.

The following table lists the configurations for terminal [FM]. Use function C027 to configure.

Func.	Code	Description	Waveform	Full Scale Value
C027	00	Output frequency	PWM	0 – Max. frequency (Hz)
	01	Output current	PWM	0 – 200%
	02	Output torque *1	PWM	0 – 200%
	03	Output frequency	FM	0 – Max. frequency (Hz)
	04	Output voltage	PWM	0 – 100%
	05	Input electric power	PWM	0 – 200%
	06	Thermal load ratio	PWM	0 – 100%
	07	LAD frequency	PWM	0 – Max. frequency (Hz)

Note 1: Display substitutes only during sensorless vector control, 0Hz domain sensorless vector control, and vector control

PWM Signal Type

The *pulse-width modulated* signal at terminal [FM] is primarily designed for driving a moving-coil meter. The pulse-width modulated signal is automatically averaged by the inertia of the moving-coil mechanism—converting the PWM signal to an analog representation. Be sure to use a 10V full-scale DC voltmeter.

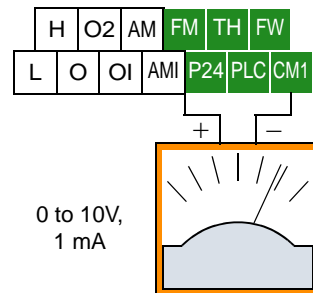

The signal characteristics of terminal [FM] in PWM signal configuration is shown below

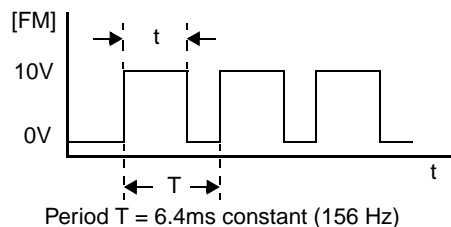

$$[FM] \text{ output value} = \frac{t}{T}$$

[B081] = [FM] terminal 8-bit gain setting

C27=00, 01, 02, 04, 05, 06, 07

Selects FM type output

To calibrate the meter reading, generate a full-scale output (always ON) at terminal [FM]. Then use parameter B081(gain setting from 0 to 255) to adjust the corresponding full-scale reading of the meter. For example, when the inverter output frequency is 60 Hz, change the value of B081 so that the meter reads 60 Hz.



TIP: When using the analog meter for monitoring, adjust the meter so it has a zero reading when the [FM] output is zero. Then use scale factor B081 to adjust the [FM] output so the maximum frequency in the inverter corresponds to a full-scale reading on the meter.



NOTE: The indicator accuracy after adjustment is about ±5%. Depending on the motor, the accuracy may exceed this value.

PWM Smoothing Circuit – Note that standard analog output signals are available on terminals [AM] and [AMI], covered in the next section. However, you may also wish to smooth the PWM signal at the [FM] terminal and convert it to an analog signal. The [FM] terminal will then generate a relatively stable DC analog voltage that represents the output value. To do this, use the circuit shown to the right. Note the output impedance of the circuit is at least 82kΩ, so the monitoring device needs an input impedance of 1MΩ or greater. Otherwise, the impedance of the smoothing circuit will cause a non-linearity in the reading.

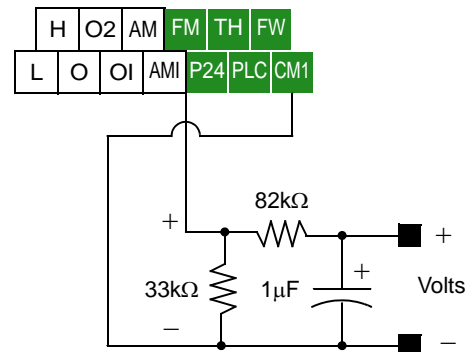

FM Signal Type

The *frequency-modulated* output at terminal [FM] varies its frequency with the inverter output frequency (when C027=03). The signal at [FM] uses the parameter A004 *Maximum frequency setting*. For example, if A004 = 60 Hz, then the maximum signal value at [FM] will be at 60 Hz. This frequency is digitally controlled for accuracy, and does not use the B081 gain setting when C027=03 (frequency modulation).

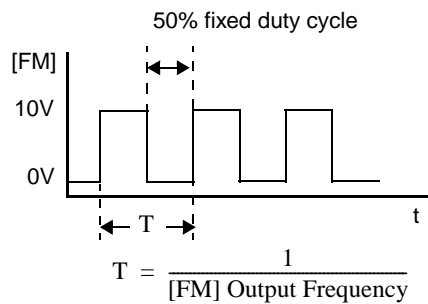

$$[FM] \text{ Output Frequency} = \frac{1}{T}$$

C027=03 Selects FM type output

[AM] and [AMI] Terminals

The [AM] and [AMI] terminals provide signals to monitor various inverter parameters such as output frequency, output current, and torque. The terminals provide these analog signal types:

- [AM] terminal: 0–10V analog output signal
- [AMI] terminal: 4–20mA analog output signal

These signals both use the [L] terminal for signal return. Eight different inverter parameters may be monitored independently at either the [AM] or [AMI] terminal, as listed in the table below. Use C028 to configure terminal [AM], and C029 to configure terminal [AMI].

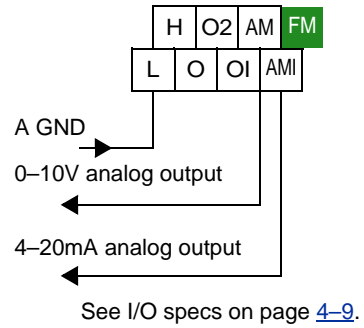

Func.	Terminal	Code	Description	Full Scale Value
C028 / C029	[AM] / [AMI]	00	Output frequency	0 – Max. frequency (Hz)
		01	Output current	0 – 200%
		02	Output torque *1	0 – 200%
		04	Output voltage	0 – 100%
		05	Input electric power	0 – 200%
		06	Thermal load ratio	0 – 100%
		07	LAD frequency	0 – Max. frequency (Hz)

Note 1: Display of torque is possible only during sensorless vector control, 0Hz domain sensorless vector control, and vector control with feedback

The analog signals may need some adjustment for gain or offset to compensate for variances in the system. For example, the signals may drive a panel meter and require a full-scale gain adjustment. The table below lists the function codes and their descriptions. The [AM] and [AMI] terminals have separate gain and offset adjustments. Note the default values.

Func.	Terminal	Description	Range	Default
B080	[AM]	Gain adjustment	0 – 255	180
C086	[AM]	Offset Adjustment	0.0 – 10.0V	0.0V
C087	[AMI]	Gain adjustment	0 – 255	80
C088	[AMI]	Offset Adjustment	0.0 – 20.0mA	0.0mA

Setting Motor Constants for Vector Control

Introduction

These advanced torque control algorithms improve performance, particularly at low speeds:

- **Sensorless Vector Control** – improved torque control at output frequencies down to 0.5 Hz. Use A044=03 (1st motor) or A244=03 (2nd motor) to select sensorless vector control.
- **Sensorless Vector Control, 0Hz Domain** – improved torque control at output frequencies from 0 to 2.5 Hz. Use A044=04 (1st motor) or A244=04 (2nd motor) to select sensorless vector control, 0Hz domain.
- **Vector Control with Feedback** – improved torque control at all speeds, while providing the most accurate speed regulation of all torque control algorithms. Use A044=05 to select vector control with feedback.

These three control algorithms require the inverter's motor constants to accurately match the characteristics of the particular motor connected to your inverter. Simply using the inverter's default parameters with the vector control modes may not produce satisfactory results. The auto-tuning procedure described later in this section is recommended for most applications needing vector control. It determines and records the characteristics of the attached motor. However, it is possible to enter the motor constants directly if the motor manufacturer has provided that data.

After performing an initial auto-tuning procedure for your motor, you have an additional option: adaptive tuning. The adaptive tuning parameters use the auto-tuning procedure's results as starting values. Then, each time the motor runs normally in your application, the inverter tunes the parameters again to match the motor. This compensates for temperature changes, etc., further optimizing the values.

The following table lists the parameters associated with motor constant settings. Function H002 selects the set of motor constants that you want the inverter to use in normal use. Standard constants (select with H002=00) include H020 to H024. Auto-tuned constants (select with H002=01) include H030 to H034. Remember that you have to do the auto-tuning procedure in this section before using either auto-tuned constants or the adaptive mode (H002=02).

Func.	Name	Data	Notes
A044 / A244 / A344	V/f characteristic curve selection, 1st / 2nd / 3rd motors	00	V/f constant torque
		01	V/f variable torque
		02	V/f free-setting curve
		03	Sensorless vector control (SLV)
		04	Sensorless vector control, 0Hz domain
		05	Vector control with encoder feedback
H002	Motor data selection, 1st motor	00	Standard motor parameters
		01	Auto-tuning parameters
		02	Adaptive tuning parameters
H003	Motor capacity, 1st motor	0.2 – 75, 0.2 – 160	kW, up to –550xxx models kW, –750xxx to –1500xxx models
H004	Motor poles setting, 1st motor	2 / 4 / 6 / 8	Units: poles
H020	Motor constant R1, 1st motor	0.000–65.53	Units: ohms
H021	Motor constant R2, 1st motor	0.000–65.53	Units: ohms
H022	Motor constant L, 1st motor	0.00–655.3	Units: mH
H023	Motor constant I _o , 1st motor	0.00–655.3	Units: A
H024	Motor constant J, 1st motor	0.001–9999	Units: kgm ²
H030	Auto-tuned constant R1, 1st motor	0.000–65.53	Units: ohms

Func.	Name	Data	Notes
H031	Auto-tuned constant R2, 1st motor	0.000–65.53	Units: ohms
H032	Auto-tuned constant L, 1st motor	0.00–655.3	Units: mH
H033	Auto-tuned constant I _o , 1st motor	0.00–655.3	Units: A
H034	Auto-tuned constant J, 1st motor	0.001–9999	Units: kgm ²

The inverter has three separate motor constant sets named *1st*, *2nd*, and *3rd*. The 1st motor constant set is the default, while the SET and SET2 intelligent inputs select the 2nd and 3rd constant sets, respectively. The torque control methods are valid to use only if a particular motor constant set includes parameters for the selected control method. The following table lists the vector control methods and shows the ones that are valid for each motor constant set.:

Vector Control Method	1st motor	2nd motor	3rd motor
V/f constant torque	✓	✓	✓
V/f variable torque	✓	✓	✓
V/f free-setting curve	✓	✓	✗
Sensorless vector control (SLV)	✓	✓	✗
Sensorless vector control, 0Hz domain	✓	✓	✗
Vector control with encoder feedback	✓	✗	✗

The motor data selection is available only to the 1st motor constant set, selected by function H004. By default, the 2nd and 3rd motor constants sets only store standard motor parameters. The table below shows this arrangement.

Motor data selection	1st motor	2nd motor	3rd motor
Standard motor parameters	✓	✓	✓
Auto-tuning parameters	✓	✗	✗
Adaptive tuning parameters	✓	✗	✗

When motor constant values are available from the motor manufacturer, you can enter them directly. The available motor constant parameters (storage locations) depend on the motor constant set (1st, 2nd, or 3rd) according to the following table.

Motor data selection	1st motor	2nd motor	3rd motor
Standard motor parameters	H020 to H024	H220 to H224	—
Auto-tuning parameters	H030 to H034	—	—
Adaptive tuning parameters	H030 to H034	—	—

Auto-tuning of Motor Constants

The SJ7002 inverter features auto-tuning, which detects and records the motor characteristic parameters to use in all vector control modes. Auto-tuning determines the resistance and inductance of motor windings. Therefore, the motor must be connected to the inverter for this procedure. Note that the auto-tuning feature is not associated with PID loop operation, which is common on some control devices. The auto-tuning procedure must be conducted while the inverter is stopped (not in Run mode), so it can use special output pulses to detect motor characteristics.

When using the inverter in sensorless vector control, sensorless vector control - 0Hz domain, or vector control with encoder feedback, the motor circuit constants are important. If they are unknown, then you must first conduct the auto-tuning procedure. The inverter will determine the constants and write new values for the related "H" Group settings. The auto-tuning procedure requires that the inverter be configured to operate the 1st motor (do not set the inverter to use 2nd and 3rd motor data during an auto-tuning procedure).

Func.	Name	Range	Notes
H001	Auto-tuning setting	00	Disabled
		01	Enabled, without motor rotation
		02	Enabled, with motor rotation
H002	Motor data selection, 1st motor	00	Standard motor parameters
		01	Auto-tuning parameters
		02	Adaptive tuning parameters
H003	Motor capacity, 1st motor	0.2 – 75, 0.2 – 160	kW, up to –550xxx models kW, –750xxx to –1500xxx models
H004	Motor poles setting, 1st motor	2 / 4 / 6 / 8	Units: poles
H030	Auto-tuned motor constant R1, 1st motor	—	Units: ohms
H031	Auto-tuned motor constant R2, 1st motor	—	Units: ohms
H032	Auto-tuned motor constant L, 1st motor	—	Units: mH
H033	Auto-tuned motor constant Io, 1st motor	—	Units: A
H034	Auto-tuned motor constant J, 1st motor	—	Units: kgm ²
A003	Base frequency setting	30 to maximum freq.	Units: Hz
A051	DC braking enable	00	Disabled (Disable during auto-tuning)
		01	Enabled
A082	AVR voltage select	200/215/220/230/240	Valid for 200V class inverters
		380/400/415/440/ 460/480	Valid for 400V class inverters

Please read the following Warning before running the auto-tuning procedure on the next page.



WARNING: You may need to disconnect the load from the motor before performing auto-tuning. The inverter runs the motor forward and backward for several seconds without regard to load movement limits.

Preparation for Auto-tuning Procedure – Be sure to study the preparation items and verify the related inverter configuration before going further in this procedure.

1. Adjust the motor base frequency (A003) and the motor voltage selection (A082) to match the specifications of the motor used in the auto-tuning procedure.
2. Verify that the motor is not more than one frame size smaller than the rated size for the inverter. Otherwise, the motor characteristic measurements may be inaccurate.
3. Be sure that no outside force will drive the motor during auto-tuning.
4. If DC braking is enabled (A051=01), the motor constants will not be accurately set. Therefore, disable DC braking (A051=00) before starting the auto-tuning procedure.
5. When auto-tuning with motor rotation (H001=02), take care to verify the following points:
 - a. The motor will rotate up to 80% of the base frequency; make sure that this will not cause any problem.
 - b. Do not attempt to either run or stop the motor during the auto-tuning procedure unless it is an emergency. If this occurs, initialize the inverter's parameters to the factory default settings (see [“Restoring Factory Default Settings” on page 6-16](#)). Then reprogram the parameters unique to your application, and initiate the auto-tuning procedure again.
 - c. Release any mechanical brake that would interfere with the motor rotating freely.
 - d. Disconnect any mechanical load from the motor. The torque during auto-tuning is not enough to move some loads.
 - e. If the motor is part of a mechanism with limited travel (such as lead screw or elevator), select H001=01 so that the auto-tuning will not cause motor rotation.
6. Note that even when you select H001=01 for no rotation, sometimes the motor will rotate.
7. When using a motor that is one frame size smaller than the inverter rating, enable the overload restriction function. Then set the overload restriction level to 1.5 times the rated output current of the motor.

After the preparations above are complete, perform the auto-tuning procedure by following the steps below.

1. Set H001=01 (auto-tuning *without* motor rotation) or H001=02 (auto-tuning *with* motor rotation).
2. Turn the Run command ON. The inverter will then automatically sequence through the following actions:
 - a. First AC excitation (motor does not rotate)
 - b. Second AC excitation (motor does not rotate)
 - c. First DC excitation (motor does not rotate)
 - d. V/F running—this step occurs only if H001=02 (motor accelerates up to 80% of the base frequency)
 - e. SLV running—this step occurs only if H001=02 (motor accelerates up to x% of the base frequency), where “x” varies with time T during this step:
 - x=40% when $T < 50s$
 - x=20% when $50s < T < 100s$
 - x=10% when $T \geq 100s$
 - f. Second DC excitation
 - g. Displays the pass/fail result of the auto-tuning (see next page)



NOTE: During the AC and DC motor excitation steps above, you may notice that the motor makes a slight humming sound. This sound is normal.

Auto-tuning Procedure

If the auto-tuning procedure is successful, the inverter updates the motor characteristic parameters and indicates *normal termination* of the procedure as shown. Pressing any key on the keypad will clear the result from the display.



Normal termination



Abnormal termination

- **Trip during auto-tuning** – A trip event will cause the auto-tuning sequence to quit. The display will show the error code for the trip rather than the abnormal termination indication. After eliminating the cause of the trip, then conduct the auto-tuning procedure again.
- **Power loss or stop during auto-tuning** – If the auto-tuning procedure is interrupted by power loss, the Stop key, or by turning OFF the Run command, the auto-tuning constants may or may not be stored in the inverter. It will be necessary to restore the inverter's factory default settings (see "[Restoring Factory Default Settings](#)" on page 6-16). After initializing the inverter, then perform the auto-tuning procedure again.
- **Free V/F setting** – The auto-tuning procedure will have an abnormal termination if the control mode of the inverter is set for free V/F setting.

Adaptive Auto-tuning of Motor Constants

The adaptive auto-tuning feature refines the motor constants by checking the motor characteristic while it is in the normal running temperature range.

Preparation for Adaptive Auto-tuning – Be sure to study the preparation items and verify the related inverter configuration before going further in this procedure.

1. It is necessary to first perform the auto-tuning procedure in the section above, since adaptive auto-tuning requires accurate initial constant values.
2. Adaptive auto-tuning is valid only for the 1st motor data (do not use 2nd or 3rd motor data settings).
3. The adaptive auto-tuning sequence actually begins as the motor decelerates to a stop from a Run command you initiate. However, the sequence still continues for five (5) more seconds. Giving another Run command during this 5-second time period will halt the adaptive auto-tuning. It will resume the next time the motor runs and decelerates to a stop.
4. If DC braking is enabled, then the adaptive auto-tuning sequence executes after DC braking brings the motor to a stop.
5. Note that when intelligent terminal [SON] Speed Servo ON or [FOC] Current Forcing is assigned, the online auto-tuning function is not available.

After reading and following the preparation steps above, then configure the inverter for adaptive auto-tuning by following these steps:

1. Set H002=02 for adaptive auto-tuning procedure
2. Set H001=00 to disable the (manual) auto-tuning procedure
3. Turn the Run command ON.
4. Run the motor for an appropriate time until it reaches its normal operating temperature range. Remember that the purpose of adaptive auto-tuning is optimize the inverter for typical running conditions.
5. Stop the motor (or turn the Run command OFF), which initiates an adaptive auto-tuning. Wait at least five (5) seconds before issuing any other command to the inverter.

With the above configuration, the inverter automatically runs the adaptive auto-tuning sequence each time the motor runs and decelerates to a stop. This continuously adapts the SLV control algorithm to slight changes in the motor constants during operation.



NOTE: It is not necessary to wait 5 seconds after each time the motor runs before running again. When the motor stops for less than 5 seconds before running again, the inverter stops the adaptive tuning sequence and keeps the current motor constant values in memory. The inverter will attempt the adaptive auto-tuning at the next run/stop event of the motor.

Manual Setting of Motor Constants

With vector control, the inverter uses the output current, output voltage, and motor constants to estimate the motor torque and speed. It is possible to achieve a high starting torque and accurate speed control at low frequency

- **Sensorless Vector Control** – improved torque control at output frequencies down to 0.5 Hz. Use A044=03 (1st motor) or A244=03 (2nd motor) to select sensorless vector control.
- **Sensorless Vector Control, 0Hz Domain** – improved torque control at output frequencies from 0 to 2.5 Hz. Use A044=04 (1st motor) or A244=04 (2nd motor). For this vector control method, we recommend using a motor that is one frame size smaller than the inverter size.
- **Sensorless Vector Control with Feedback** – improved torque control at all speeds, while providing the most accurate speed regulation

If you do use any vector control methods, it is important that the motor constants stored in the inverter match the motor. We recommend first using the auto-tuning procedure in the previous section. If satisfactory performance through auto-tuning cannot be fully obtained, please adjust the motor constants for the observed symptoms according to the table below.



CAUTION: If the inverter capacity is more than twice the capacity of the motor in use, the inverter may not achieve its full performance specifications.

Operation Status	Symptom	Adjustment	Parameter
Powered running	When the speed deviation is negative	Slowly increase the motor constant R2 in relation to auto-tuning data, within 1 to 1.2 times preset R2	H021 / H221
	When the speed deviation is positive	Slowly decrease the motor constant R2 in relation to auto-tuning data, within 0.8 to 1 times preset R2	H021 / H221
Regeneration (status with a decelerating torque)	When low frequency (a few Hz) torque is insufficient	Slowly increase the motor speed constant R1 in relation to auto-tuning data within 1 to 1.2 times R1	H020 / H220
		Slowly increase the motor constant IO in relation to auto-tuning data, within 1 to 1.2 times preset IO	H023 / H223
During acceleration	A sudden jerk at start of rotation	Increase motor constant J slowly within 1 to 1.2 times the preset constant	H024 / H224
During deceleration	Unstable motor rotation	Decrease the speed response	H05, H205
		Set motor constant J smaller than the preset constant	H024, H224
During torque limiting	Insufficient torque during torque limit at low speed	Set the overload restriction level lower than the torque limit level	B021, B041 to B044
At low-frequency operation	Irregular rotation	Set motor constant J larger than the preset constant	H024, H244

When using a motor one frame size smaller than the inverter rating, the torque limit value (B041 to B044) is from the following formula and the value of the actual motor torque limit is calculated by the formula. Do not set a value in B041 to B044 that results in an actual torque greater than 200% or you risk motor failure.

For example, suppose you have a 0.75kW inverter and a 0.4kW motor. The torque limit setting value that is for T=200% is set (entered) as 106%, shown by the following formula:

$$\text{Torque limit setting} = \frac{\text{Actual torque limit} \times \text{Motor capacity}}{\text{Inverter capacity}} = \frac{200\% \times 0.4\text{kW}}{0.75\text{kW}} = 106\%$$

PID Loop Operation

In standard operation, the inverter uses a reference source selected by parameter A001 for the output frequency, which may be a fixed value (F001), a variable set by the front panel potentiometer, or value from an analog input (voltage or current). To enable PID operation, set A071 = 01. This causes the inverter to *calculate* the target frequency, or setpoint. An optional intelligent input assignment (code 23), PID Disable, will temporarily disable PID operation when active.

A calculated target frequency can have a lot of advantages. It lets the inverter adjust the motor speed to optimize some other process variable of interest, potentially saving energy as well. Refer to the figure below. The motor acts upon the external process. To control that external process, the inverter must monitor the process variable. This requires wiring a sensor to either the analog input terminal [O] (voltage) or terminal [OI] (current).

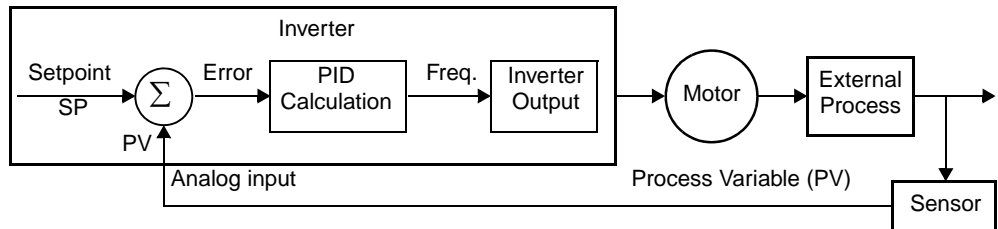

When enabled, the PID loop calculates the ideal output frequency to minimize the loop error. This means we no longer command the inverter to run at a particular frequency, but we specify the ideal value for the process variable. That ideal value is called the *setpoint*, and is specified in the units of the external process variable. For a pump application it may be gallons/minute, or it could be air velocity or temperature for an HVAC unit. Parameter A075 is a scale factor that relates the external process variable units to motor frequency. The figure below is a more detailed diagram of the PID function.

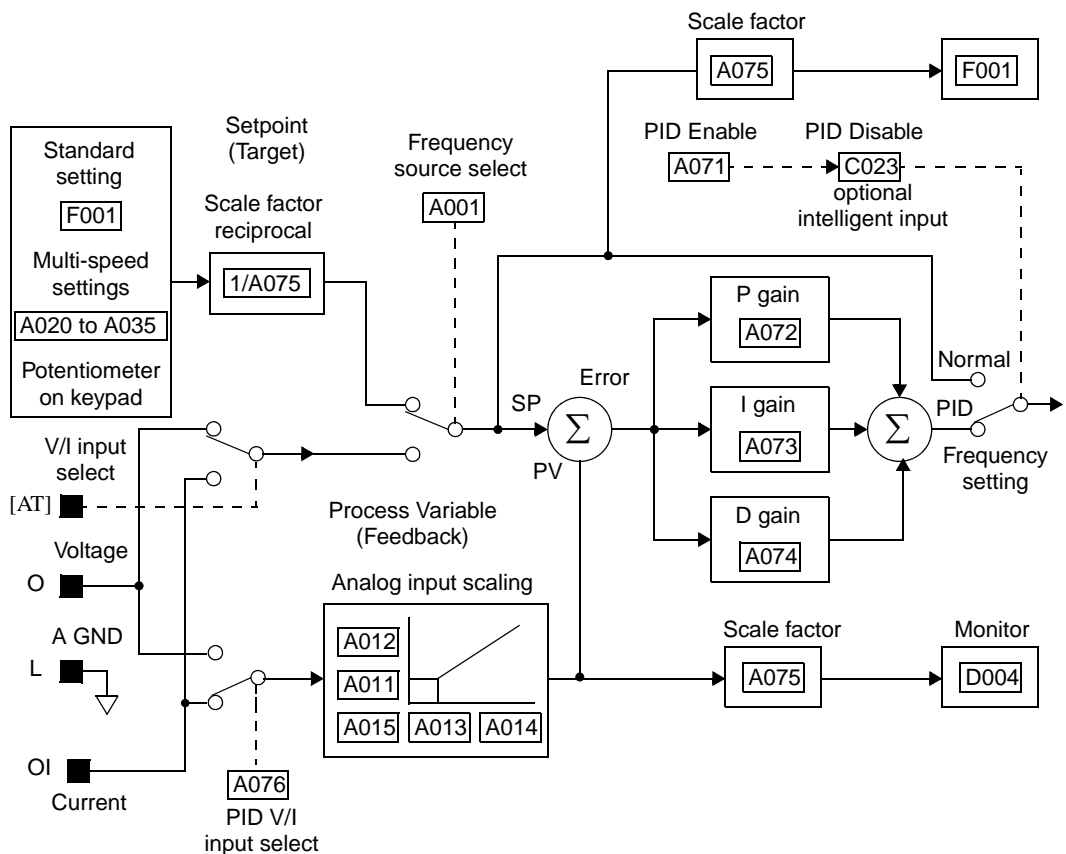

Operations and Monitoring

Configuring the Inverter for Multiple Motors

Simultaneous Connections

For some applications, you may need to connect two or more motors (wired in parallel) to a single inverter's output. For example, this is common in conveyor applications where two separate conveyors need to have approximately the same speed. The use of two motors may be less expensive than making the mechanical link for one motor to drive multiple conveyors.

Some of the requirements when using multiple motors with one drive are:

- Use only V/F (variable-frequency) control; do not use SLV (sensorless vector control).
- The inverter output must be rated to handle the sum of the currents from the motors.
- You must use separate thermal protection switches or devices to protect each motor. Locate the device for each motor inside the motor housing or as close to it as possible.
- The wiring for the motors must be permanently connected in parallel (do not remove one motor from the circuit during operation).

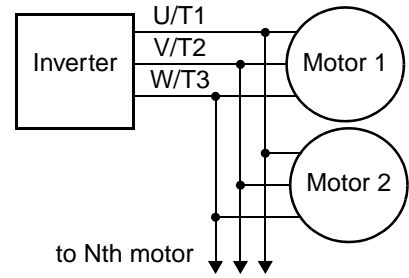

NOTE: The motor speeds are identical only in theory. That is because slight differences in their loads will cause one motor to slip a little more than another, even if the motors are identical. Therefore, do not use this technique for multi-axis machinery that must maintain a fixed position reference between its axes.

Inverter Configuration for Multiple Motor Types

Some equipment manufacturers may have a single type of machine that has to support three different motor types—and only one motor will be connected at a time. For example, an OEM may sell basically the same machine to the US market and the European market. Some reasons why the OEM needs two motor profiles are:

- The inverter power input voltage is different for these markets.
- The required motor type is also different for each destination.

In other cases, the inverter needs two profiles because the machine characteristics vary according to these situations:

- Sometimes the motor load is very light and can move fast. Other times the motor load is heavy and must move slower. Using two profiles allows the motor speed, acceleration and deceleration to be optimal for the load and avoid inverter trip (fault) events.
- Sometimes the slower version of the machine does not have special braking options, but a higher performance version does have braking features.

Having multiple motor profiles lets you store several “personalities” for motors in one inverter's memory. The inverter allows the final selection between the three motor types to be made in the field through the use of intelligent input terminal functions [SET] and [SET3]. This provides an extra level of flexibility needed in particular situations. See the following page.

Parameters for the second motor and third motors have function codes of the form x2xx and x3xx respectively. They appear immediately after the first motor's parameter in the menu listing order. The following table lists the parameters that have the second/third parameter registers for programming.

Function Name	Parameter Codes		
	1st motor	2nd motor	3rd motor
Acceleration time setting (Acceleration 1)	F002	F202	F302
Deceleration time setting (Deceleration 1)	F003	F203	F303
Base frequency setting	A003	A203	A303
Maximum frequency setting	A004	A204	A304
Multi-speed frequency setting	A020	A220	A320
Torque boost method selection	A041	A241	—
Manual torque boost value	A042	A242	A342
Manual torque boost frequency adjustment	A043	A243	A343
V/F characteristic curve selection	A044	A244	A344
Automatic torque boost voltage gain	A046	A246	—
Automatic torque boost slip gain	A047	A247	—
Frequency upper limit setting	A061	A261	—
Frequency lower limit setting	A062	A262	—
Second acceleration time setting (Acceleration 2)	A092	A292	A392
Second deceleration time setting (Deceleration 2)	A093	A293	A393
Select method to use 2nd acceleration/deceleration	A094	A294	—
Acc1 to Acc2 frequency transition point	A095	A295	—
Dec1 to Dec2 frequency transition point	A096	A296	—
Level of electronic thermal setting	B012	B212	B312
Select electronic thermal characteristic	B013	B213	B313
Select motor constant	H002	H202	—
Motor capacity setting	H003	H203	—
Motor poles setting	H004	H204	—
Motor constant Kp setting (Standard, Auto tuning)	H005	H205	—
Motor stabilization constant	H006	H206	—
Motor constant R1 setting (Standard, Auto tuning)	H020/H030	H220/H230	—
Motor constant R2 setting (Standard, Auto tuning)	H021/H031	H221/H231	—
Motor constant L setting (Standard, Auto tuning)	H022/H032	H222/H232	—
Motor constant Io setting (Standard, Auto tuning)	H023/H033	H223/H233	—

Function Name	Parameter Codes		
	1st motor	2nd motor	3rd motor
Motor constant J setting (Standard, Auto tuning)	H024/H034	H224/H234	—
PI proportional gain	H050	H250	—
P proportional gain setting	H052	H252	—
0Hz SLV limit for 1st motor	H060	H260	—

Inverter System Accessories



5

In This Chapter....

page

— Introduction	2
— Component Descriptions	3
— Dynamic Braking	6

Introduction

A motor speed control system will obviously include a motor and inverter, as well as fuses for safety. If you are connecting a motor to the inverter on a test bench just to get started, that's all you may need for now. But a fully developed system can also have a variety of additional components. Some can be for noise suppression, while others may enhance the inverter's braking performance. The figure below shows a system with several possible optional components, and the table gives part number information.

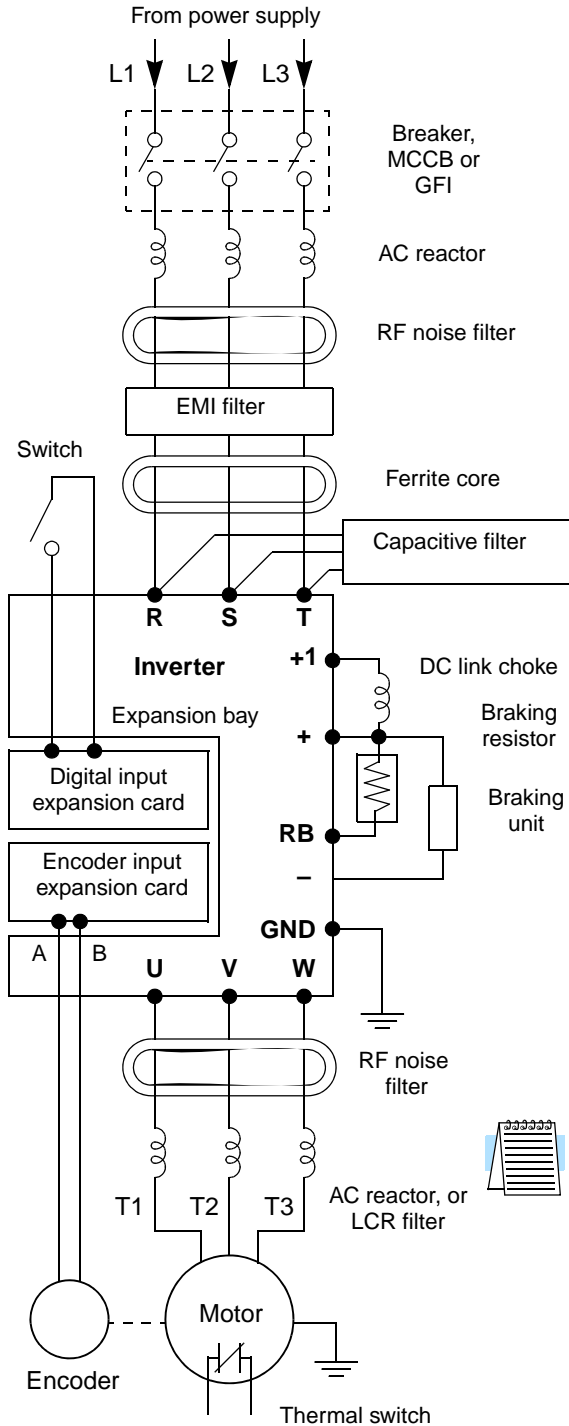

Name	Part No. Series		See page
	Europe, Japan	USA	
AC reactor, input side	ALI-xxx	HRL-x	5-3
RF noise filter, input side	ZCL-x	ZCL-x	5-4
EMI filter (EMC Class A)	NF-CEHx	NF-CEHxx	5-4
EMI filter (EMC Class B)	NF-CEHx, with FC-Hx	NF-CEHxx, with FC-Hx	5-4
Capacitive filter	CFI-x	CFI-x	5-4
DC link choke	—	HDC-xxx	5-4
Braking resistor	JRB-xxx-x, SRB-xxx-x	JRB-xxx, SRB-xxx	—
Braking resistor, NEMA-rated	DCL-x-xx	HRB1-x, HRB2-x, HRB3-x	—
Resistance braking unit	BRD-xxx	BRD-xxx	—
RF noise filter, output side	ZCL-xxx	ZCL-xxx	5-4
AC reactor, output side	ALI-xxx	HRL-xxx	5-3
LCR filter	—	HRL-xxxC	5-3
Encoder feed-back expansion	SJ-FB		5-5
Digital input expansion card	SJ-DG		5-5

NOTE: The Hitachi part number series for accessories includes different sizes of each part type, specified by the -x suffix. Hitachi product literature can help match size and rating of your inverter to the proper accessory size.

Each inverter accessory comes with its own printed instruction manual. Please refer to those manuals for complete installation details. This chapter gives only an overview of these optional system devices. For more information on Hitachi inverter system accessories, please contact your Hitachi sales office or distributor.

Component Descriptions

AC Reactors, Input Side

This is useful in suppressing harmonics induced on the power supply lines, or when the main power voltage imbalance exceeds 3% (and power source capacity is more than 500 kVA), or to smooth out line fluctuations. It also improves the power factor.

In the following cases for a general-purpose inverter, a large peak current flows on the main power supply side, and is able to destroy the inverter module:

- If the unbalanced factor of the power supply is 3% or higher
- If the power supply capacity is at least 10 times greater than the inverter capacity (the power supply capacity is 500 kVA or more)
- If abrupt power supply changes are expected

Examples of these situations include:

1. Several inverters are connected in parallel, sharing the same power bus
2. A thyristor converter and an inverter are connected in parallel, sharing the same power bus
3. An installed phase-advance (power factor correction) capacitor opens and closes

Where these conditions exist or when the connected equipment must be highly reliable, install an AC reactor between the power supply and the inverter. Also, where the effects of an indirect lightning strike is possible, install a lightning conductor.

Example calculation:

$V_{RS} = 205V$, $V_{ST} = 203V$, $V_{TR} = 197V$,

where V_{RS} is R-S line voltage, V_{ST} is S-T line voltage, V_{TR} is T-R line voltage

$$\text{Unbalance factor of voltage} = \frac{\text{Max. line voltage (min.)} - \text{Mean line voltage}}{\text{Meanline voltage}} \times 100$$

$$= \frac{V_{RS} - (V_{RS} + V_{ST} + V_{TR})/3}{(V_{RS} + V_{ST} + V_{TR})/3} \times 100 = \frac{205 - 202}{202} \times 100 = 1.5\%$$

Please refer to the documentation that comes with the AC reactor for installation instructions.

AC Reactor or LCR Filter, Output Side

This reactor reduces the vibrations in the motor caused by the inverter's switching waveforms, by smoothing the waveforms to approximate commercial power quality. It is also useful to reduce the reflected voltage wave phenomenon when wiring from the inverter to the motor is more than 10m in length. Please refer to the documentation that comes with the AC reactor for installation instructions.

Zero-phase Reactor (RF Noise Filter)

Electrical noise interference may occur on nearby equipment such as a radio receiver. The zero-phase reactor helps reduce radiated noise from the inverter wiring. It can be used on the input or output side of the inverter. The example zero-phase reactor shown to the right comes with a mounting bracket. The wiring must go through the opening to reduce the RF component of the electrical noise. Loop the wires three times (four turns) to attain the full RF filtering effect. For larger wire sizes, place multiple zero-phase reactors (up to four) side-by-side for a greater filtering effect.



ZCL-x

EMI Filter

The EMI filter reduces the conducted noise on the power supply wiring generated by the inverter. Connect the EMI filter to the inverter primary (input side). The NF-CEH-x series filter is required for compliance to the EMC Class A directive (Europe) and C-TICK (Australia). See [“CE-EMC Installation Guidelines” on page D-2](#).



WARNING: The EMI filter has high internal leakage current from power wiring to the chassis. Therefore, connect the chassis ground of the EMI filter before making the power connections to avoid danger of shock or injury.



NF-CEHxx

Ferrite Core

To meet EMC Class B limit an optional ferrite core (FC-Hx) must be inserted between the NF-CEHx filter (above) and the inverter.

RF Noise Filter (Capacitive)

This capacitive filter reduces radiated noise from the main power wires in the inverter input side. This filter is not for achieving CE compliance and is applicable only to the input side only of the inverter. It comes in two versions—for 200V class inverters or 400V class inverters. Please refer to the documentation that comes with the radio noise filter for installation instructions.

DC Link Choke

The DC choke (reactor) suppresses harmonics generated by the inverter. It attenuates the high-frequency components on the inverter's internal DC bus (link). However, note that it does not protect the diode rectifiers in the inverter input circuit.

Expansion Cards

The SJ-FB Encoder Feedback Board installs in the inverter's expansion bay, which can accept up to two expansion cards. The encoder card accepts two-channel incremental encoder signals. Position feedback is essential for certain torque-control algorithms, and is useful for improving low-speed performance. The card can also generate linear acceleration/deceleration ramps for velocity control.

All wiring associated with this card connects to its PWB connectors as shown. Some related signals may be assigned to the intelligent I/O terminals, as described in Chapter 4. For more information, refer to the SJ-FB manual.

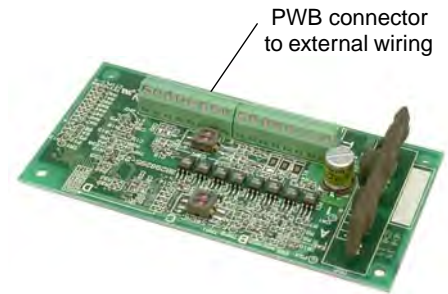

SJ-FB Encoder Feedback Card

The SJ-DG Digital Input Card installs in the inverter's expansion bay. This card accepts up to eight digital input signals, in addition to the intelligent inputs on the inverter's control terminal connector. All wiring associated with card connects to its PWB connectors as shown.

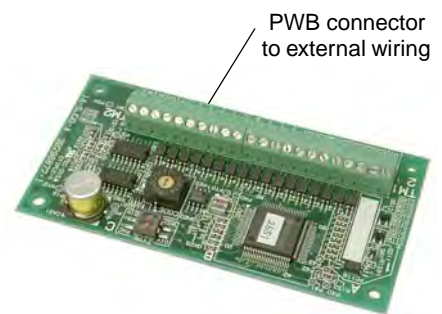

SJ-DG Digital Input Card

The SJ-DN DeviceNet Interface Card (not shown) installs in the inverter's expansion bay. It connects directly to a DeviceNet network. Inverter parameters P044 to P049 configure the card. Only one DeviceNet card may be installed in an inverter. For more information, please refer to the DeviceNet Expansion Card Instruction Manual.

Dynamic Braking

Introduction

The purpose of dynamic braking is to improve the ability of the inverter to stop (decelerate) the motor and load. This becomes necessary when an application has some or all of the following characteristics:

- High load inertia compared to the available motor torque
- The application requires frequent or sudden changes in speed
- System losses are not great enough to slow the motor as needed

When the inverter reduces its output frequency to decelerate the load, the motor can temporarily become a generator. This occurs when the motor rotation frequency is higher than the inverter output frequency. This condition can cause the inverter DC bus voltage to rise, resulting in an over-voltage trip. In many applications, the over-voltage condition serves as a warning signal that we have exceeded the deceleration capabilities of the system. SJ7002 inverters rated 15hp (11kW) and below have a built-in braking unit that sends the regenerative energy from the motor during deceleration to the optional braking resistor(s). External braking units may also be used if higher braking torques and/or duty cycles are required. The dynamic braking resistor serves as a load, developing heat to stop the motor just as brakes on an automobile develop heat during braking.

The braking resistor is the main component of a braking resistor assembly, which includes an integral thermal fuse and thermally activated alarm relay for safety. However, be careful to avoid overheating its resistor. The thermal fuse and thermal relay are safeguards for extreme conditions, but the inverter can maintain braking usage in a safe zone.



Braking Resistor

Dynamic Braking Usage Ratio

The inverter controls braking via a duty cycle method (percent of the time braking is ON versus total time). Parameter B090 sets the dynamic braking usage ratio. In the graph to the right, the example shows three uses of dynamic braking in a 100-second period. The inverter calculates the average percentage usage in that time (duty cycle %). The percentage of usage is proportional to the heat dissipated. If the duty cycle is greater than the B090 parameter setting, the inverter enters the Trip Mode and turns OFF the frequency output.

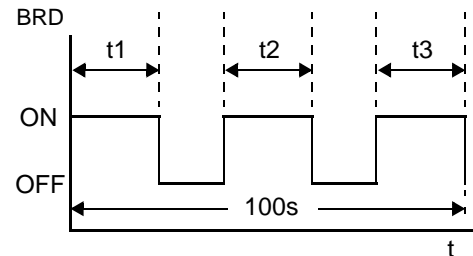

$$\boxed{\text{B90}} \text{ Duty cycle} = \frac{(t1 + t2 + t3 + \dots)}{100 \text{ seconds}} \times 100$$

Please note the following (for SJ700-055xFU2 to SJ700-220xFU2).

- When B090 is set for 0%, dynamic braking is not performed.
- When the duty cycle value exceeds the limit set by B090, the inverter will trip (ending the dynamic braking).
- The cable from the external resistor to the inverter must not exceed 5 m (16 ft.) length.
- The wires from the DB resistor to the inverter must not be bundled together with control or signal wires.



NOTE: Inverters rated 40hp (30kW) and above (SJ700-300xFU2 and larger models) do not include an internal braking unit. Parameters B090, B095, and B096 do not apply to these models.

Dynamic Braking Selection Tables

The SJ7002 Series 200V and 400V class inverter models in the 1/2 to 30 HP range have internal braking units. Additional stopping torque is available by adding external resistors. The required braking torque depends on your particular application. Other tables in this section will help you choose the proper resistor.

1/2 to 30 HP (0.4 to 22 kW)			Without External Resistor		Using Optional External Resistor		Performance @ Minimum Resistance		Minimum Resistance @ 100% Braking Duty Cycle, Ohms
Voltage Class	Model Number	Motor HP	Braking Unit	Braking Torque @ 60Hz, %	External Resistance, Ohms	Braking Torque @60Hz, %	Minimum Resistance, Ohms	Max. Braking Duty Cycle, %	
200V	SJ700-004LFUF2	0.5	Built-in	20	48	150	48	10	150
	SJ700-007LFUF2	1	Built-in	20	48	150	48	10	150
	SJ700-015LFUF2	2	Built-in	20	32	150	32	10	110
	SJ700-022LFUF2	3	Built-in	20	32	150	32	10	110
	SJ700-037LFUF2	5	Built-in	20	32	110	32	10	110
	SJ700-055LFUF2	7.5	Built-in	20	16	140	16	10	50
	SJ700-075LFUF2	10	Built-in	20	10	150	10	10	50
	SJ700-110LFUF2	15	Built-in	10	10	110	10	10	50
	SJ700-150LFUF2	20	Built-in	10	7.5	110	7.5	10	35
	SJ700-185LFU2	25	Built-in	10	7.5	90	7.5	10	35
SJ700-220LFU2	30	Built-in	10	5	110	5	10	35	
400V	SJ700-007HFUF2 SJ700-007HFEF2	1	Built-in	20	100	150	70	10	300
	SJ700-015HFUF2 SJ700-015HFEF2	2	Built-in	20	100	150	70	10	300
	SJ700-022HFUF2 SJ700-022HFEF2	3	Built-in	20	70	150	70	10	300
	SJ700-040HFUF2 SJ700-040HFEF2	5	Built-in	20	70	150	70	10	200
	SJ700-055HFUF2 SJ700-055HFEF2	7.5	Built-in	20	70	130	70	10	200
	SJ700-075HFUF2 SJ700-075HFEF2	10	Built-in	20	70	150	35	10	150
	SJ700-110HFUF2 SJ700-110HFEF2	15	Built-in	10	50	130	35	10	150
	SJ700-150HFUF2 SJ700-150HFEF2	20	Built-in	10	35	140	24	10	100
	SJ700-185HFU2/E	25	Built-in	10	35	140	24	10	100
SJ700-220HFU2/E	30	Built-in	10	35	110	20	10	100	



NOTE: For inverters larger than 30 HP (22kW), an external braking unit will be required. Contact your distributor or Hitachi for assistance.



Troubleshooting and Maintenance



In This Chapter....	page
— Troubleshooting	2
— Monitoring Trip Events, History, & Conditions	5
— Restoring Factory Default Settings	16
— Maintenance and Inspection	17
— Warranty	29

Troubleshooting

Safety Messages Please read the following safety messages before troubleshooting or performing maintenance on the inverter and motor system.



WARNING: Wait at least ten (10) minutes after turning OFF the input power supply before performing maintenance or an inspection. Otherwise, there is the danger of electric shock.



WARNING: Make sure that only qualified personnel will perform maintenance, inspection, and part replacement. Before starting to work, remove any metallic objects from your person (wristwatch, bracelet, etc.). Be sure to use tools with insulated handles. Otherwise, there is a danger of electric shock and/or injury to personnel.



WARNING: Never remove connectors by pulling on its wire leads (wires for cooling fan and logic P.C. board). Otherwise, there is danger of fire due to wire breakage and/or injury to personnel.

General Precautions and Notes

- Always keep the unit clean so that dust or other foreign matter does not enter the inverter.
- Take special care to avoid breaking wires or making connection mistakes.
- Firmly connect terminals and connectors.
- Keep electronic equipment away from moisture and oil. Dust, steel filings and other foreign matter can damage the inverter, causing unexpected accidents, so take special care.

Inspection Items

This chapter provides instructions or checklists for these inspection items:

- Daily inspection
- Periodic inspection (approximately once a year)
- Insulation resistance test

Troubleshooting Tips

The table below lists typical symptoms and the corresponding solution(s).

Symptom/condition		Probable Cause	Solution
The motor will not run.	The inverter outputs U, V, W are not supplying voltage.	<ul style="list-style-type: none"> Is the frequency command source A001 parameter setting correct? Is the Run command source A002 parameter setting correct? 	<ul style="list-style-type: none"> Make sure the parameter setting A001 is correct. Make sure the parameter setting A002 is correct.
		<ul style="list-style-type: none"> Is power being supplied to terminals [R], [S], and [T] ([L1], [L2], and [L3])? If so, the POWER lamp should be ON. 	<ul style="list-style-type: none"> Check terminals [R], [S], and [T] ([L1], [L2], and [L3]), then [U], [V], and [W] ([T1], [T2], and [T3]). Turn ON the power supply or check fuses.
		<ul style="list-style-type: none"> Is there an error code E - - - displayed? 	<ul style="list-style-type: none"> Press the FUNC. key and determine the error type. Eliminate the error cause, then clear the error (Reset).
		<ul style="list-style-type: none"> Are the signals to the intelligent input terminals correct? Is the Run Command active? Is the [FW] terminal (or [RV]) connected to P24 (via switch, etc.) 	<ul style="list-style-type: none"> Verify the terminal functions for C001 - C008 are correct. Turn ON Run command enable. Supply 24V to [FW] or [RV] terminal, if configured.
		<ul style="list-style-type: none"> Has the frequency setting for F001 been set greater than zero? Are the control circuit terminals [H], [O], and [L] connected to the potentiometer? 	<ul style="list-style-type: none"> Set the parameter for F001 to a safe, non-zero value. If the potentiometer is the frequency setting source, verify voltage at [O] > 0V.
		<ul style="list-style-type: none"> Is the RS (reset) function or FRS (free-run stop) function ON? 	<ul style="list-style-type: none"> Turn OFF the command(s).
	Inverter outputs U, V, W are supplying voltage.	<ul style="list-style-type: none"> Is the motor load too heavy? 	<ul style="list-style-type: none"> Reduce load or test the motor independently of the load.
The direction of the motor is reversed.	<ul style="list-style-type: none"> Are the connections of output terminals [U/T1], [V/T2], and [W/T3] correct? Is the phase sequence of the motor forward or reverse with respect to [U/T1],[V/T2], and [W/T3]? 	<ul style="list-style-type: none"> Make connections according to the phase sequence of the motor. In general: FWD = U-V-W, and REV=U-W-V. 	
	<ul style="list-style-type: none"> Are the control terminals [FW] and [RV] wired correctly? Is parameter F004 properly set? 	<ul style="list-style-type: none"> Use terminal [FW] for forward, and [RV] for reverse. Set motor direction in F004. 	

Symptom/condition		Probable Cause	Solution
The motor speed will not reach the target frequency (desired speed).		<ul style="list-style-type: none"> • If using the analog input, is there current or voltage at [O] or [OI]? 	<ul style="list-style-type: none"> • Check the wiring. • Check the potentiometer or signal generating device.
		<ul style="list-style-type: none"> • Is the load too heavy? 	<ul style="list-style-type: none"> • Reduce the load. • Heavy loads activate the overload restriction feature (reduces output as needed).
		<ul style="list-style-type: none"> • Is the inverter internally limiting the output frequency? 	<ul style="list-style-type: none"> • Check max frequency setting (A004) • Check frequency upper limit setting (A061) • If using analog inputs, check their settings (A101– A104) or (A111–A114), or (A011–A014)
The rotation is unstable.		<ul style="list-style-type: none"> • Is the load fluctuation too great? • Is the supply voltage unstable? • Is the problem occurring at a particular frequency? 	<ul style="list-style-type: none"> • Increase the motor capacity (both inverter and motor). • Fix power supply problem. • Change the output frequency slightly, or use the jump frequency setting to skip the problem frequency.
The RPM of the motor does not match the inverter output frequency setting.		<ul style="list-style-type: none"> • Is the maximum frequency setting A004 correct? • Does the monitor function D001 display the expected output frequency? 	<ul style="list-style-type: none"> • Verify the V/F settings match motor specifications. • Make sure all scaling (such as A011 to A014) is properly set.
A parameter will not change after an edit (reverts to old setting).	True for certain parameters	<ul style="list-style-type: none"> • Is the inverter in Run Mode? Some parameters cannot be edited during Run Mode. 	<ul style="list-style-type: none"> • Put inverter in Stop Mode (press the Stop/reset key). Then edit the parameter.
	True for all parameters	<ul style="list-style-type: none"> • If you're using the [SFT] intelligent input (software lock function)—is the [SFT] input ON? 	<ul style="list-style-type: none"> • Change the state of the SFT input, and check the B031 parameter (SFT mode).

Monitoring Trip Events, History, & Conditions

Fault Detection and Clearing

The microprocessor in the inverter detects a variety of fault conditions and captures the event, recording it in a history table. The inverter output turns OFF, or “trips” similar to the way a circuit breaker trips due to an over-current condition. Most faults occur when the motor is running (refer to the diagram to the right). However, the inverter could have an internal fault and trip in Stop Mode. In either case, you can clear the fault by pressing the Stop/Reset key. Additionally, you can clear the inverter’s cumulative trip history by performing the procedure [“Restoring Factory Default Settings” on page 6-16](#) (setting B_84=00 will clear the trip history but leave inverter settings intact).

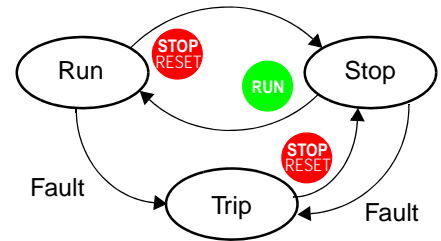

Error Status Codes

The conditions at the time of an error provide important clues to help you understand the cause. The SJ7002 inverter displays a “status at trip point” digit to the right of the decimal point for some error codes. For example, **E07.2** means Error 7 occurred and the inverter status was condition # “2” when the error occurred.

Status Codes	Inverter Status	Status Codes	Inverter Status
---.0	Reset	---.5	Run Command active with 0 Hz speed reference
---.1	Stop	---.6	Starting
---.2	Deceleration	---.7	DC braking
---.3	Constant speed	---.8	Overload restriction
---.4	Acceleration	---.9	SON or FOC operation in progress

Error Codes

An error code will appear on the display automatically when a fault causes the inverter to trip. The following table lists the cause associated with the error.

OPE/SRW Display	Name	Description	Troubleshooting and Corrective Action
E01.- OC.Drive	Over-current protection	If the motor is constrained or suddenly accelerated or decelerated, a high current will flow in the inverter and the inverter may fail. To avoid this problem, the inverter shuts off its output and displays the error code shown on the left when it detects a current higher than a specified level. This protective function uses a DC current detector (CT) to detect over-current. When a current as high as about 220% of the inverter's rated output current is detected, the protective circuit operates and the inverter trips.	During constant speed operation
E02.- OC.Decel	Over-current protection		During deceleration
E03.- OC.Accel	Over-current protection		During acceleration
E04.- Over.C	Over-current protection		Other conditions
E05.- OL.BRD	Overload protection (*1) (*4)	This protective function monitors the inverter output current, and shuts off the inverter output and displays the error code shown on the left when the internal electronic thermal protection circuit detects a motor overload. If the error occurs, the inverter will trip according to the setting of the electronic thermal function.	<ul style="list-style-type: none"> Check whether the motor load is too high. (reduce the load factor). Check whether the thermal level is appropriate (adjust the level appropriately). <p>Note: The electronic thermal protection is easily triggered when the output frequency is 5 Hz or less. If the moment of inertia of the load is large, this protective function may operate when the inverter accelerates the motor and the acceleration may be disabled. If this problem occurs, increase the torque boost current or adjust other settings as needed.</p>
E06.- OL.BRD	Braking resistor overload protection	When the BRD operation rate exceeds the setting of B090, this protective function shuts off the inverter output and displays the error code shown on the left.	<ul style="list-style-type: none"> Check whether the inverter has decreased the motor quickly (increase the deceleration time). Check whether the operation cycle is too short (prolong the operation cycle) Check whether the set BRD operation rate is too low (adjust the setting to an appropriate level). <p>Note: Confirm the maximum allowable capacity of the resistor.</p>

OPE/SRW Display	Name	Description	Troubleshooting and Corrective Action
E07.- Over.V	Over-voltage protection	If the DC voltage across the P and N terminals rises too high, an inverter failure may result. To avoid this problem, this protective function shuts off the inverter output and displays the error code shown on the left when the DC voltage across the P and N terminals exceeds a specified level because of an increase in the energy regenerated by the motor or the input voltage (during operation). The inverter will trip if the DC voltage across the P and N terminals exceeds about 400 VDC (in case of the 200 V class models) or about 800 VDC (in case of the 400 V class models).	<ul style="list-style-type: none"> • Check whether the inverter has decreased the motor quickly (increase the deceleration time). • Check for a ground fault (check the output cables and motor). • Check whether the motor has been rotated by the action of the load (reduce the regenerative energy).
E08.- EEPROM	EEPROM error (*2) (*3)	When an internal-EEPROM is caused by external noise or an abnormal temperature rise, the inverter shuts off its output and displays the error code shown on the left. Note: An EEPROM error may result in a CPU error.	<ul style="list-style-type: none"> • Check for the noise sources located near the inverter (remove noise sources). • Check whether the cooling efficiency has deteriorated (check the heat sink for clogging and clean it). • Check the cooling fan (replace if needed).
E09.- Under.V	Under-voltage	If the inverter input voltage drops, the control circuit of the inverter cannot function normally. Therefore, the inverter shuts off its output when the input voltage falls below a specified level. The inverter will trip if the DC voltage across the P and N terminals exceeds about 175 VDC (in case of the 200 V class models) or about 345 VDC (in case of the 400 V class models).	<ul style="list-style-type: none"> • Check whether the power supply voltage has dropped (check the power supply). • Check whether the power supply capacity is sufficient (check the power supply). • Check whether the thyristor has been damaged (check the thyristor).
E10.- CT	CT error	If an error occurs in the internal current detector (CT), the inverter will shut off its output and display the error code shown on the left. The inverter will trip when the CT outputs about 0.6 V or more at power-on.	<ul style="list-style-type: none"> • Check whether the inverter has failed (repair the inverter).

Note 1: The inverter will not accept any reset command within about 90 seconds after tripping (i.e., after the protective function operates). Be sure to turn OFF the input power supply after waiting two minutes for cooling.

Note 2: The inverter will not accept any reset command after an EEPROM error occurs with error code displayed. Turn off the inverter power once. If error code E08 is displayed when the inverter power is turned on subsequently, the internal memory device may have failed or parameters may have not been stored correctly. In such cases, initialize the inverter, and then reset the parameters.

Note 3: The inverter will not accept reset commands input via the RS terminal or entered by the STOP/RESET key. Therefore, turn off the inverter power.

Note 4: Be sure to reduce the inverter's output current and the motor load before restarting after overload protection (E05). If the continuous reset/restart operations for error E05 could cause damage to the inverter.



NOTE: If an EEPROM error E08 occurs, be sure to confirm the parameter data values are still correct.

OPE /SRW Display	Name	Description	Troubleshooting and Corrective Action
E11.- CPU	CPU error (*5)	If the internal CPU malfunctions or an error occurs in it, the inverter will shut OFF its output and display the error code shown on the left. Note: Reading abnormal data from the EEPROM may result in a CPU error.	<ul style="list-style-type: none"> • Check for the noise sources located near the inverter (remove noise sources). • Check whether the inverter has failed (repair the inverter).
E12.- EXTERNAL	External trip	If an error occurs in the external equipment or device connected to the inverter, the inverter will latch the error signal and shut off its output. (This protective function is active when the external trip function is enabled.)	<ul style="list-style-type: none"> • If the inverter's external trip function is enabled, check whether an error has occurred in external equipment (clear the error in the external equipment).
E13.- USP	USP error	A USP error is indicated when the inverter power is turned on with an input operation signal remaining in the inverter. (This protective function is active when the USP function is enabled.)	<ul style="list-style-type: none"> • If the USP function has been enabled, check whether the inverter power has been turned on with an input operation signal remaining in the inverter (reset the operation command, and then turn ON the inverter power).
E14.- GND.Flt	Ground fault protection (*5)	When the inverter power is turned ON, this protective function detects the ground fault between the inverter output circuit and the motor to protect the inverter. (This function does not operate when a residual voltage remains in the motor.)	<ul style="list-style-type: none"> • Check for the ground fault (check the output cables and motor). • Check the inverter itself for abnormality (remove the output cables from the inverter, and then check the inverter). • Check the main circuit for abnormality (use testing methods described in this chapter and repair the inverter).
E15.- OV.SRC	Input over-voltage protection	This protective function determines an error if the input voltage is kept above the specification level for 100 seconds while the inverter is stopped. The inverter will trip if the DC voltage of the main circuit is kept above about 390 VDC (in case of the 200 V class models) or about 780 VDC (in case of the 400 V class models).	<ul style="list-style-type: none"> • Check whether the input voltage is high while the inverter is stopped (lower the input voltage, suppress the power voltage fluctuation, or connect an AC reactor between the power supply and the inverter input.)
E16.- Inst.P-F	Instantaneous power failure protection	If an instantaneous power failure lasts 15 ms or more, the inverter will shut off its output. When the power failure duration is long, the inverter assumes a normal power-OFF. If a restart mode has been selected and an operation command remains in the inverter, the inverter will restart after the power is recovered.	<ul style="list-style-type: none"> • Check whether the power supply voltage has dropped (recover the power supply). • Check the MCB and magnetic contactors for poor contacts (replace the MCB and the magnetic contactor).
E20.- OH.stFAN	Temperature error due to low cooling-fan speed	The inverter will display the error code shown on the left if the lowering of cooling fan speed is detected at the occurrence of the temperature error described below.	<ul style="list-style-type: none"> • Check whether the cooling efficiency has been lowered (replace the cooling fan). • Check the heat sink for clogging (clean the heat sink).
E21.- OH.fin	Temperature error	If the main circuit temperature rises because of a high ambient temperature or for other reasons, the inverter will shut OFF its output.	<ul style="list-style-type: none"> • Check whether the inverter is installed vertically (check the installation.) • Check whether the ambient temperature is high (lower the ambient temperature).

Note 5: The inverter will not accept reset commands input via the [RS] terminal or entered by the STOP/RESET key. Therefore, turn off the inverter power.

OPE/SRW Display	Name	Description	Troubleshooting and Corrective Action
E23.- GA.COM	Gate array communication error	If an error occurs in the communication between the internal CPU and gate array, the inverter will trip.	<ul style="list-style-type: none"> • Check for the noise sources located near the inverter (remove noise sources). • Check whether the communication cable has been disconnected (check the connectors).
E24.- PH.fail	Phase loss input protection	When the phase loss input protection has been enabled (B006 = 01), the inverter will trip to avoid damage if an phase loss input is detected. The inverter trips when the phase loss input continues for about 1 second or more.	<ul style="list-style-type: none"> • Check for the phase loss power input. (check the power supply input wiring). • Check the MCB and magnetic contactors for poor contacts (replace the MCB and magnetic contactors).
E25.- Main.Cir	Main circuit error (*6)	The inverter will trip if the gate array cannot confirm the ON/OFF state of IGBT because of a malfunction due to noise, short or damage to the main circuit element.	<ul style="list-style-type: none"> • Check for the noise sources located near the inverter (remove noise sources.) • Check the main circuit element for damage. Check the output circuit for a short circuit (check the IGBT). • Check the inverter for abnormality (repair the inverter).
E30.- IGBT	IGBT error (*7)	If instantaneous over-current occurs, the main circuit element temperature is abnormal, or the main circuit element drive power drops, the inverter will turn OFF its output to protect the main circuit element. (After tripping because of this protective function, the inverter cannot retry the operation.)	<ul style="list-style-type: none"> • Check the output circuit for a short circuit (check the output cables). • Check for the ground fault (check the output cables and motor). • Check the main circuit element for damage (check the IGBT). • Check the heat sink for clogging (clean the heat sink).
E35.- TH	Thermistor error	The inverter monitors the resistance of the thermistor (in the motor) connected to the inverter's [TH] terminal, and will turn OFF the inverter output if the motor temperature rises.	<ul style="list-style-type: none"> • Check whether the motor temperature is high (check the motor temperature). • Check whether the internal thermistor of the motor has been damaged (check the thermistor). • Check whether noise has been mixed in the thermistor signal (separate the thermistor wiring from other wirings).
E36.- BRAKE	Braking error	When "01" has been specified for B120 Brake Control Enable, the inverter will trip if it cannot receive the braking confirmation signal within B124 Brake Wait Time for Confirmation after the output of the brake release signal.	<ul style="list-style-type: none"> • Check whether the brake has been turned on and off or not (check the brake). • Check whether the wait time (B124) is too short (increase the wait time B124). • Check whether the braking confirmation signal has been input (check the wiring).
E37.- EMR	Emergency stop (*8)	If the EMR signal (on three terminals) is turned ON when the slide switch (SW1) on the logic board is set to ON, the inverter hardware will turn OFF the inverter output and display the error code shown on the left. The malfunction is due to incoming noise when EMR terminal is not ON.	<ul style="list-style-type: none"> • Check whether an error has occurred in the external equipment since the emergency stop function was enabled. (recover the external equipment from the error.) • Check for the noise sources located near the inverter (remove noise sources).
E38.- OL-LOWSP	Low-speed overload protection	If overload occurs during the motor operation at a very low speed at 0.2 Hz or less, the electronic thermal protection circuit in the inverter will detect the overload and shut off the inverter output (2nd electronic thermal control). Note: A high frequency may be recorded as the error history data.	<ul style="list-style-type: none"> • Check whether the motor load is too high (reduce the load factor).

OPE /SRW Display	Name	Description	Troubleshooting and Corrective Action
E41.- NET.ERR	ModBus communication error	If time-out occurs because of line disconnection during the communication in ModBus-RTU mode, the inverter will display the error code shown on the left. (The inverter will trip according to the setting of C076.)	<ul style="list-style-type: none"> • Check whether the communication speed setting is correct. • Check whether the wiring distance is appropriate (check the connections).
E50.- E0 E59.- OP1-0 OP1-9	Option 1 error	The inverter detects errors in the option board mounted in the optional slot 1. For details, refer to the instruction manual for the mounted option board.	<ul style="list-style-type: none"> • Check whether the option board is mounted correctly (check the board mounting). • Check whether the option board is used correctly (refer to the instruction manual for the option board SJ-FB, SJ-DG, or SJ-DN).

Note 6: The inverter will not accept reset commands input via the RS terminal or entered by the STOP/RESET key. Therefore, turn off the inverter power.

Note 7: The inverter applied for 004 to 110L/H will not accept reset commands input via the RS terminal or entered by the STOP/RESET key. Therefore, turn off the inverter power.

Note 8: The inverter will not accept the reset command entered from the digital operator. Therefore, reset the inverter by turning on the RS terminal.



NOTE: If an EEPROM error (E08) occurs, be sure to confirm the parameter data values are still correct.

Expansion Card Error Codes

The inverter monitors the operation of the expansion cards (optional) that may be installed in the expansion bay.

On the inverter's digital operator, error codes in the E60 range refer to the upper card position. Error codes in the E70 range refer to the lower card position. For the remote operator display, error codes are in the OP1 or OP2 ranges, respectively. If an error occurs, the inverter trips (displays the corresponding error code and turns OFF the motor output).

Encoder Input Card – Use the following table to diagnose errors caused by an encoder input expansion card. Each error will cause the inverter to trip, turning OFF its output and displaying an error code.

Error range:

E6x or OP1

E7x or OP2



Encoder Input Expansion Card Errors		
Error Code: OPE / SRW	Name	Probable Cause(s)
E60.- E70.-	Encoder disconnect	Encoder wiring to the expansion card is disconnected
OP1-0 OP2-0		The encoder is faulty
		The encoder type is not correct (no line driver output, etc.)
E61.- E71.-	Excessive speed	The motor speed increased to the maximum frequency (A004) times the over-speed error detection level (P026)
OP1-1 OP2-1		
E62.- E72.-	Positioning error	While in position control mode the position error (command minus actual) reached 1,000,000 pulses or more
OP1-2 OP2-2		
E63.- E73.-	Position control range trip	While in absolute position control mode, the actual position exceeded the forward (P072) or reverse (P073) position range value
OP1-3 OP2-3		
E69.- E79.-	SJ-FB connection error	The SJ-FB expansion card is not mounted properly or the card is faulty
OP1-9 OP2-9		

If an encoder expansion card does not operate normally, use the following table to check the DIP switch settings on the card.

DIP Switch	Switch Number	Setting
SWENC	1	ON setting enables encoder disconnect function for loss of A or B channel
	2	ON setting enables encoder disconnect function for loss of Z channel
SWR	1	ON setting connects the 150Ω termination resistor across terminals [SAP] and [SAN]
	2	ON setting connects the 150Ω termination resistor across terminals [SBP] and [SBP]

Digital Input Card – Use the following table to diagnose errors caused by a digital input expansion card. Each error will cause the inverter to trip, turning OFF its output and displaying an error code.

Digital Input Expansion Card Errors		
Error Code: OPE / SRW	Name	Probable Cause(s)
E60- E70-	Digital input expansion card error	A communications time-out between the inverter and the digital input card has occurred
OP1-0 OP2-0		

The input mode is determined by a combination of DIP switch and rotary switch settings. If the expansion card does not operate normally, use the following table to check the DIP switch and rotary switch settings. The check marks indicate input modes specified by switch settings. For more details, refer to the expansion card instruction manual.

DIP Switch		Rotary Switch	Frequency Setting, Hz				Accel / Decel Time, Seconds			Torque limit Setting	Position Setting	
1	2	Code	0.01	0.1	1	Rate	0.01	0.1	1	1%	1 pulse	
OFF: BIN (binary input) / ON: BCD (binary coded decimal input)	OFF: PAC (batch input mode)	0										
		1										
		2										
		3										
		4									✓	
		5										
		6										✓
		ON: DIV (divided input mode)	0	✓				✓			✓	✓
			1						✓			
			2							✓		
			3		✓			✓				
			4						✓			
			5								✓	
			6				✓	✓				
			7							✓		
			8								✓	
			9					✓	✓			
			A							✓		
			B								✓	

Troubleshooting and Maintenance

DeviceNet Expansion Card – Use the following table to diagnose errors caused by a DeviceNet expansion card. Each error will cause the inverter to trip (according to parameter settings P045 and P048), turning OFF its output and displaying an error code.

DeviceNet Expansion Card Errors		
Error Code: OPE /SRW	Name	Probable Cause(s)
E60.- E70.-	DeviceNet Communication Error	The communication speed may be incorrect
OP1-0 OP2-0		The network wiring length may not be appropriate
		A connector is loose (or wire not connected)
E61.- E71.-	Duplicate MAC ID	Two or more devices on the network have the same MAC ID
OP1-1 OP2-1		
E62.- E72.-	External trip	Check the Force Fault/Trip bit. Attribute 17 in the Instance 1 of Class 19 may be set to 1. If so, clear the bit to 0.
OP1-2 OP2-2		
E69.- E79.-	Inverter communication error	The expansion card may not be properly connected to the inverter
OP1-9 OP2-9		

If the expansion card does not operate normally, use the following diagrams to check the DIP switch settings. For more details, refer to the expansion card instruction manual.

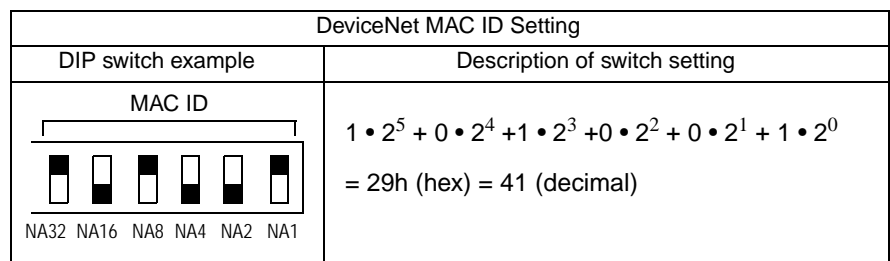
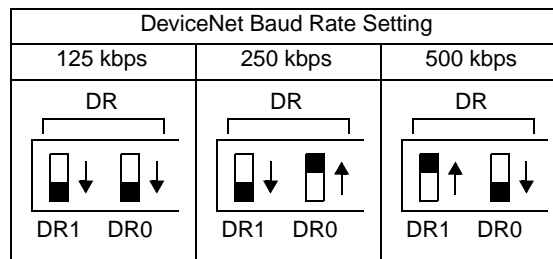

Easy Sequence Error Codes

Use the following table to diagnose errors related to Easy Sequence programming. The error code will appear when the related program runs.

DeviceNet Expansion Card Errors		
Error Code: OPE / SRW	Name	Probable Cause(s)
<i>E43-</i>	Invalid instruction	A program contains an invalid instruction
PRG.CMD		The [PRG] terminal was turn ON but a program was not loaded
<i>E44-</i>	Nesting count error	Subroutines with FOR and NEXT instructions are nested more than eight levels
PRG.NST		
<i>E45-</i>	Execution error 1	A FOR (or another) instruction to begin nesting is not found at the jump destination of a GO TO instruction, and the NEXT (or another) instruction to end nesting precedes the beginning of nesting
PRG.ERR1		An arithmetic operation resulted in overflow or underflow, or a divide-by-zero was attempted
		A CHG PARAM or MON PARAM instruction attempts to: <ul style="list-style-type: none"> • Reference an undefined parameter • Set a value outside the range for a parameter • Update a parameter that cannot be changed during inverter operation
<i>E50- ... E59-</i>	User trip event	A TRIP instruction was executed in a program
PRG-0 ... PRG-9		

Trip History and Inverter Status

We recommend that you first find the cause of the fault before attempting clearing it. When a fault occurs, the inverter stores important performance data at the moment of the fault. To access the data, use the monitor functions (Dxxx) and select D081 for details about the present fault (E_n). The previous five faults are stored in D081 to D086, with D (E_{n-1} to E_{n-5}). Each error shifts D081–D085 to D082–D086, and writes the new error to D081.



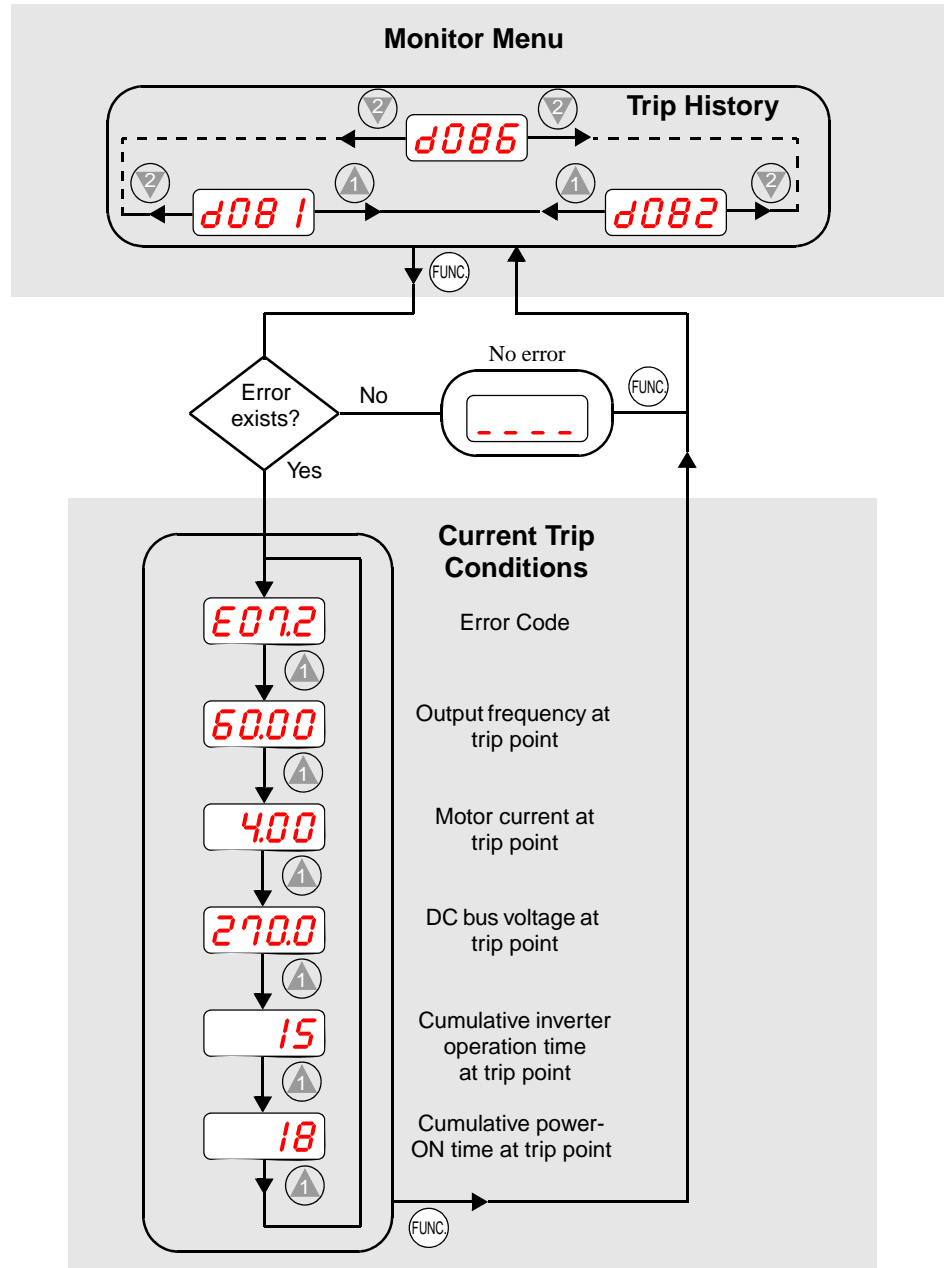









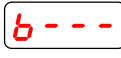













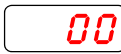







The following Monitor Menu map shows how to access the error codes. When fault(s) exist, you can review their details by first selecting the proper function: D081 is most recent, and D086 is the oldest.

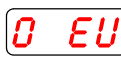

Troubleshooting and Maintenance

Restoring Factory Default Settings

You can restore all inverter parameters to the original factory (default) settings for the intended country of use. After initializing the inverter, use the powerup test in Chapter 2 to get the motor running again. To initialize the inverter, follow the steps below.

No.	Action	Display	Func./Parameter
1	Use the  ,  , and  keys to navigate to the “B” Group.		“B” Group selected
2	Press the  key.		First “B” parameter selected
3	Press and hold the  key until ->		Country code for initialization selected
4	Press the  key.		00 = Japan, 01 = Europe, 02 = U.S.
5	Confirm the country code is correct. Do not change it unless you are absolutely sure the power input voltage range and frequency match the country code setting. To change the country code, press  or  to set;  to store.		
6	Press the  key.		Country code for initialization selected
7	Press the  key.		Initialization function selected
8	Press the  key.		00 = initialization disabled, clear trip history only
9	Press the  key.		01 = enable initialization
10	Press the  key.		Initialization now enabled to restore all defaults
11	Press and hold the  and  keys together, and immediately press and hold the  key. Do not release these keys yet.		First part of special key sequence, the “B” in the display begins flashing
12	Holding the keys above, press and hold the  (STOP) key for 3 sec.		Entire “B084” display will begin flashing
13	When the  display begins flashing, release the  key.	 or 	Default parameter country code shown during initialization process (left-most character displays alternating pattern)
14	Release the  ,  , and  keys together.		Final part of key sequence, function code for output frequency monitor shown after initialization is complete

Maintenance and Inspection

Monthly and Yearly Inspection Chart

Item Inspected		Check for...	Inspection Cycle		Inspection Method	Criteria
			Month	Year		
General	Ambient environment	Extreme temperatures & humidity	✓		Thermometer, hygrometer	Ambient temperature between -10 to 50°C, non-condensing
	Major devices	Abnormal vibration, noise	✓		Visual and aural	Stable environment for electronic controls
	Power supply voltage	Voltage tolerance	✓		Digital volt meter, measure between inverter terminals [L1], [L2], [L3]	200V class: 200 to 240V 50/60 Hz 400V class: 380 to 460V 50/60 Hz
Main circuits	Ground Insulation	Adequate resistance		✓	Megger test	500VDC, reading of 5M ohms or greater, see next section for test details
	Mounting	No loose screws		✓	Torque wrench	M3: 0.5 – 0.6 Nm M4: 0.98 – 1.3 Nm M5: 1.5 – 2.0 Nm
	Components	Overheating		✓	Thermal trip events	No trip events
	Housing	Dirt, dust		✓	Visual	Vacuum dust and dirt
	Terminal block	Secure connections		✓	Visual	No abnormalities
	Smoothing capacitor	Leaking, swelling	✓		Visual	No abnormalities
	Relay(s)	Chattering		✓	Aural	Single click when switching ON or OFF
	Resistors	Cracks or discoloring		✓	Visual	Use Ohm meter to check braking resistors
Cooling system	Cooling fan	Noise	✓		Power down, manually rotate	Rotation must be smooth
	Heat sink	Dust	✓		Visual	Vacuum to clean
Control circuit	General	No odor, discoloring, corrosion		✓	Visual	No abnormalities
	Capacitor	No leaks or deformation	✓		Visual	Undistorted appearance
Display	LEDs	Legibility	✓		Visual	All LED segments work

Item Inspected		Check for...	Inspection Cycle		Inspection Method	Criteria
			Month	Year		
Motor	General	Vibration	✓		Visual, touch	Ordinary range
		Unusual odor	✓		Look for signs of overheating	Normal appearance
	Insulation resistance	Isolation boundary fault		✓	Disconnect motor from inverter, do megger test on motor	500V class megger test must pass

Note 1: The life of a capacitor is affected by the ambient temperature. See [“Capacitor Life Curve” on page 6-20](#).

Note 2: The inverter must be cleaned periodically. If dust accumulates on the fan and heat sink, it can cause overheating of the inverter.

Megger Test

The *megger* is a piece of test equipment that uses a high voltage to determine if an insulation degradation has occurred. For inverters, it is important that the power terminals be isolated from the Earth GND terminal via the proper amount of insulation.

The circuit diagram below shows the inverter wiring for performing the megger test. Just follow the steps to perform the test:

1. Remove power from the inverter and wait at least 10 minutes before proceeding.
2. Open the front housing panel to access the power wiring.
3. Remove all wires to terminals [R, S, T, PD, P, N, RB, U, V, and W]. Most importantly, the input power and motor wires will be disconnected from the inverter.
4. Remove the jumper at connector J61. It is located on the main circuit board beside the power terminals.
5. Use a bare wire and short terminals [R, S, T, PD, P, N, RB, U, V, and W] together as shown in the diagram.
6. Connect the megger to the inverter Earth GND and to the shorted power terminals as shown. Then perform the megger test at 500 VDC and verify 5M Ω or greater resistance.

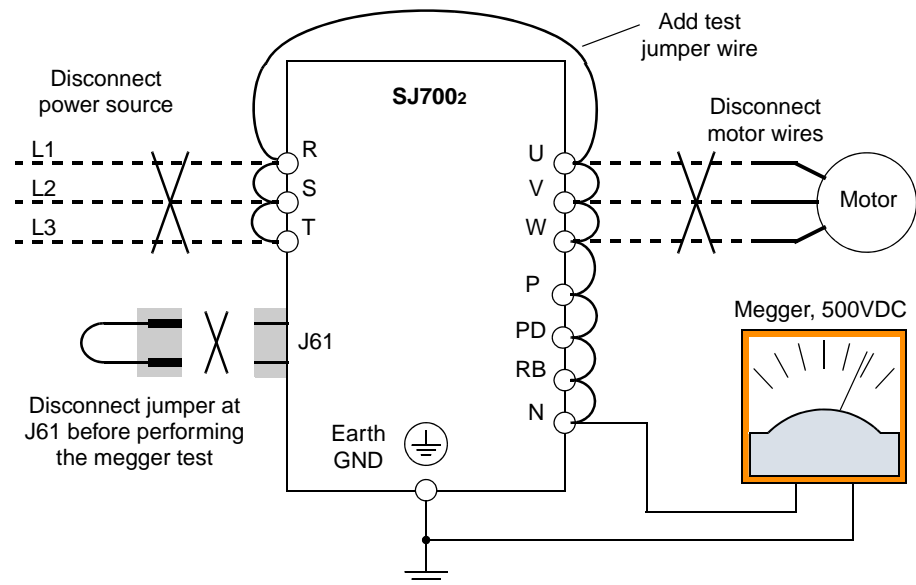

7. After completing the test, disconnect the megger from the inverter.
8. Reconnect the jumper at connector J61 as before.
9. Reconnect the original wires to terminals [R, S, T, PD, P, N, RB, U, V, and W].



CAUTION: Do not connect the megger to any control circuit terminals such as intelligent I/O, analog terminals, etc. Doing so could cause damage to the inverter.



CAUTION: Never test the withstand voltage (HIPOT) on the inverter. The inverter has a surge protector between the main circuit terminals above and the chassis ground.

Spare parts

We recommend that you stock spare parts to reduce down time, including parts listed below:

Part description	Symbol	Quantity		Notes
		Used	Spare	
Cooling fan	FAN	1, 2, 3... (depends on model)	1 or 2	Fan unit at top of housing in all models
Auxiliary cooling fan	FAN	0 or 1... (depends on model)	0 or 1	-150Lxx, -185Lxx, and -220Lxx models
Capacitor bank	CB	1	1	All models

Capacitor Life Curve

The DC bus inside the inverter uses a large capacitor as shown in the diagram below. The capacitor handles high voltage and current as it smooths the power for use by the inverter. So, any degradation of the capacitor will affect the performance of the inverter. The capacitor bank in SJ7002 series inverters is replaceable. This section will show you how to replace it in the field.

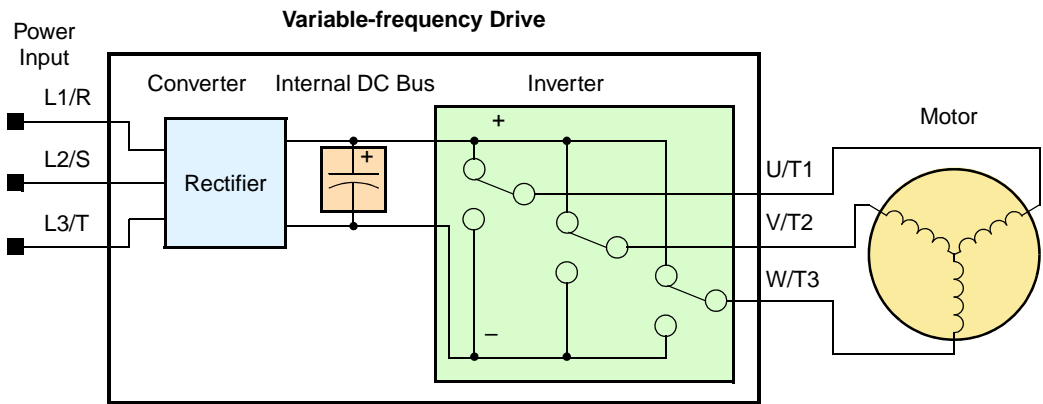

Capacitor life is reduced in higher ambient temperatures, as the graph below demonstrates. Be sure to keep the ambient temperature at acceptable levels, and perform maintenance inspections on the fan, heat sink, and other components. If the inverter is installed on a cabinet, the ambient temperature is the temperature inside the cabinet.

Capacitor Life Curve

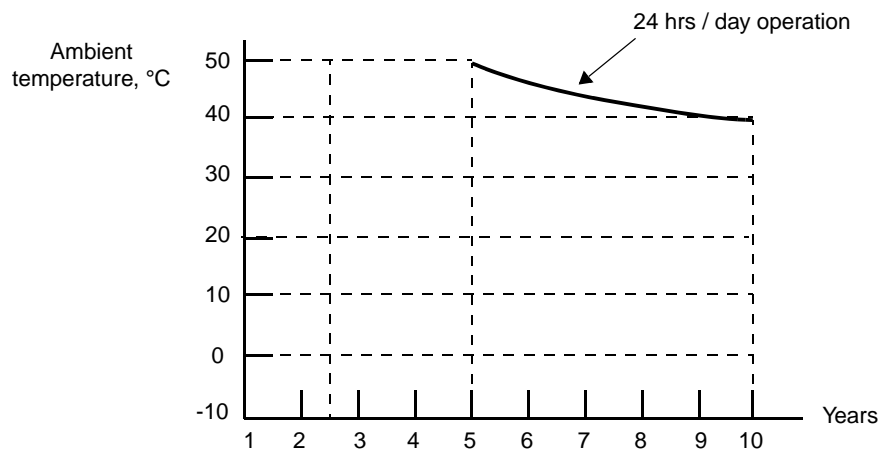

Troubleshooting and Maintenance

Capacitor Replacement

The DC section of the inverter main circuit uses high-capacity aluminum electrolytic capacitors as smoothing filter components. Since chemical reactions occur inside the capacitors, the service life of these parts depends mainly on the ambient temperature and operating conditions. Capacitors used in a standard operating environment must be replaced after about 10 years. However, each capacitor must be immediately replaced if it fails a visual inspection or if periodic inspections shows the capacity to be 80% or less of the component rating.



WARNING: The screws that retain the capacitor bank assembly are part of the electrical circuit of the high-voltage internal DC bus. Be sure that all power has been disconnected from the inverter, and that you have waited at least 10 minutes before accessing the terminals or screws. Be sure the charge lamp is extinguished. Otherwise, there is the danger of electrocution to personnel.



CAUTION: Do not operate the inverter unless you have replaced the two screws that connect the capacitor bank assembly to the internal DC bus. Otherwise, damage to the inverter may occur.

For inverters above 11kW output with molded plastic housings...

1. Loosen the two screws that secure the *lower* front panel. Remove the panel from the inverter.
2. Turn OFF power to the inverter and confirm that the Charge Indicator LED is OFF.
3. Remove the wiring entry/exit plate from the inverter.
4. Remove the screws that connect the capacitor unit to the main circuit terminal block.
5. Remove the screws that secure the capacitor mounting plate to the inverter casing.
6. Pull down the capacitor mounting plate.
7. Remove the capacitor unit from the capacitor mounting plate.

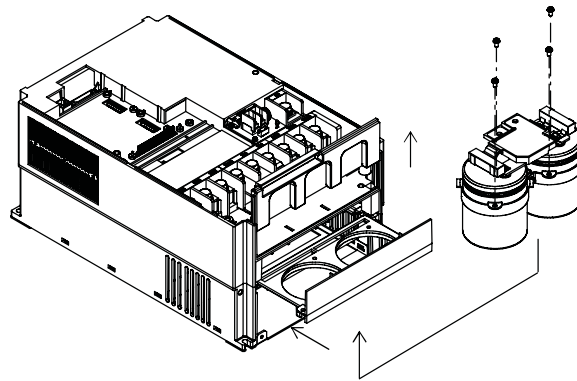

To install the new capacitor unit:

1. Place the capacitor unit on the mounting plate.
2. Slide the capacitor mounting plate into the guides in the inverter housing. Push the capacitor unit until the metal plate is flush with the housing.
3. Connect the capacitor unit to the main circuit terminal block by using the two (2) terminal screws.
4. Secure the capacitor mounting plate to the inverter housing by using the screws.
5. Replace the wire/entry plate.
6. Replace the lower front panel cover and secure it with screws.

For inverters with sheet metal housings...

1. Loosen the two screws that secure the *lower* front panel. Remove the panel from the inverter.
2. Turn OFF power to the inverter and confirm that the Charge Indicator LED is OFF.
3. Remove the lower screws from terminal block terminals [P] and [N].
4. Remove the screws that secure the capacitor mounting plate.
5. Pull down the capacitor mounting plate.
6. Remove the bus bar and resistors. Then remove the capacitor unit from the capacitor mounting plate.

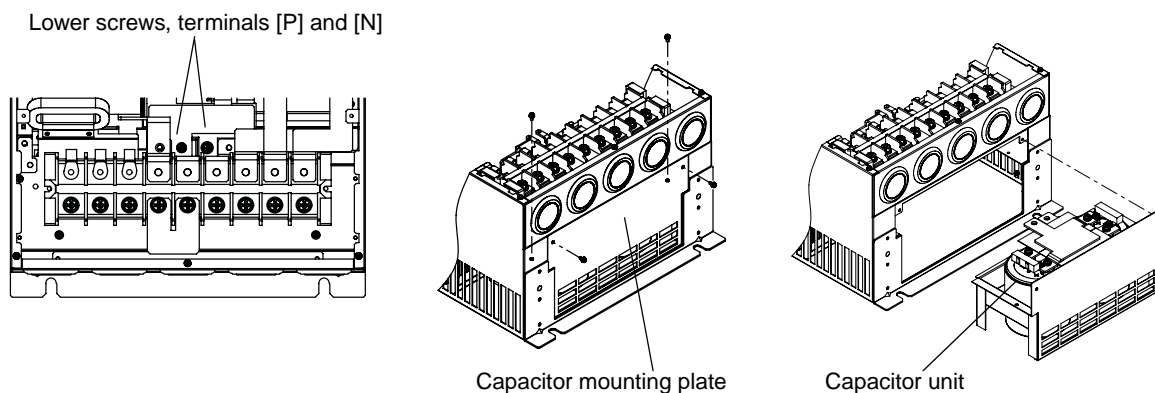

To install the new capacitor unit:

1. Place the capacitor unit on the mounting plate and secure the unit with screws.
2. Mount the bus bar and resistors in the original positions and secure them with screws.
3. Slide the capacitor mounting plate into the inverter housing.
4. Secure the capacitor mounting plate to the inverter housing by using the screws.
5. Install the lower screws in the terminal block terminals [P] and [N].
6. Mount the terminal block cover.

For inverters 11kW output and below with molded plastic housings...

The inverters in this category do not have separate capacitor units. It is necessary to replace the main circuit board, accessible by following the steps below.

1. Loosen the two screws that secure the *lower* front panel. Remove the panel from the inverter.
2. Turn OFF power to the inverter and confirm that the Charge Indicator LED is OFF.
3. Loosen the two screws that secure the *upper* front panel. Remove the panel from the inverter.
4. Press the tabs inward on each side of the cooling fan unit and lift the unit away from the top of the inverter housing.
5. Disconnect the fan unit wiring on the circuit board at the top of the inverter.
6. Disconnect the ribbon cable that connects the control board and main board.
7. Remove the wiring entry/exit plate and the jumper between terminal [P] and [PD] on the main board.
8. Remove the two (2) screws in the plastic housing, and remove the top half of the housing. Be careful not to damage the plastic tabs at the top corners of the housing.

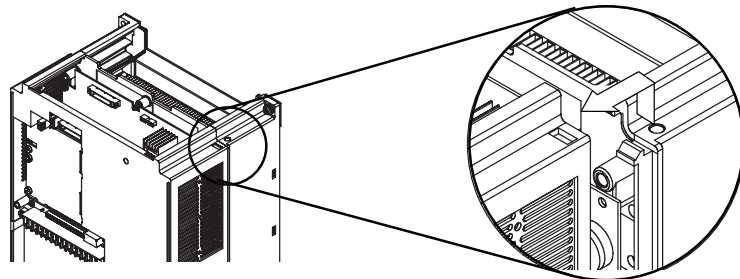
**Fan Assembly Replacement**

The SJ7002 Series inverters have field-replaceable fan units. The service life of the cooling fan bearings is approximately 100,000 hours. However, actual results vary with the inverter operating environment. Inverters running continuously usually need fan unit replacement at 10-year intervals. In addition, fan unit replacement is required immediately if the fan has abnormal sound or vibration. The fan replacement procedure depends according to the model (housing type).

For inverters with molded plastic housings...

1. Loosen the two screws that secure the *lower* front panel. Remove the panel from the inverter.
2. Turn OFF power to the inverter and confirm that the Charge Indicator LED is OFF.
3. Loosen the two screws that secure the *upper* front panel. Remove the panel from the inverter.
4. Press the tabs inward on each side of the cooling fan unit and lift the unit away from the top of the inverter housing.
5. Disconnect the fan unit wiring on the circuit board at the top of the inverter.
6. Remove the defective fan(s) from the cooling fan mounting plate.

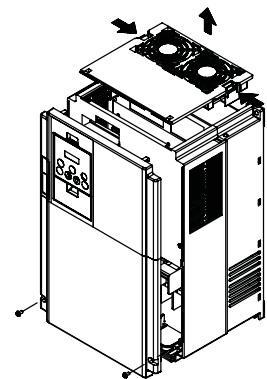

To install the new fan(s):

1. Slide the fan(s) into the mounting locations in the mounting plate. To ensure the correct airflow, be sure that the label on each fan faces toward the vent openings (top of inverter).
2. Connect the fan wiring to terminals J21 or J22 (depending on the inverter model) on the main circuit board.
3. Put the mounting plate in position on the top of the inverter. Press downward on the fan units until the retention tabs click into place.
4. Replace the upper and lower front panel covers on the inverter, using two (2) screws for each panel.

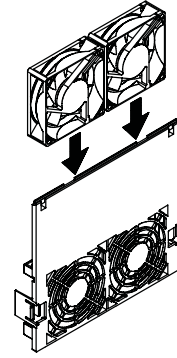

For inverters with sheet metal housings...

1. Loosen the screws that secure the *lower* front panel. Remove the panel from the inverter.
2. Turn OFF power to the inverter and confirm that the Charge Indicator LED is OFF.
3. Loosen the two screws that secure the *upper* front panel. Remove the panel from the inverter.
4. Remove the screws that secure the fan unit to the top of the inverter.
5. Lift the cooling fan unit away from the top of the inverter housing.
6. Remove the defective fan(s) from the cooling fan mounting plate.

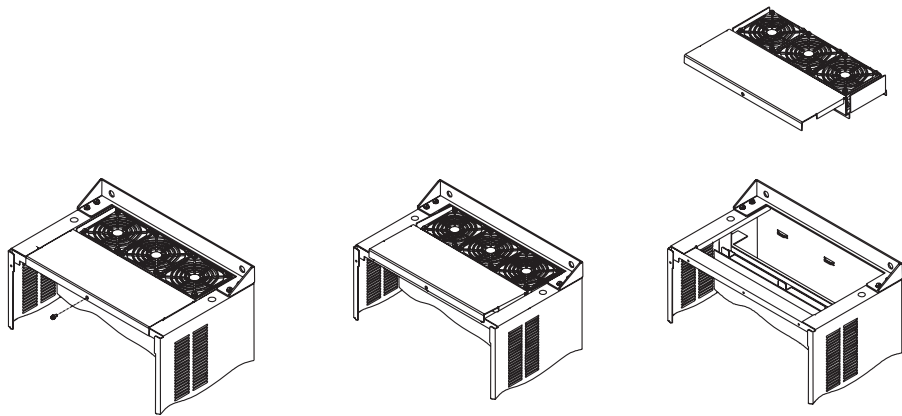

To install the new fan(s):

1. Slide the fan(s) into the mounting locations in the mounting plate. To ensure the correct airflow, be sure that the label on each fan faces toward the vent openings (top of inverter).
2. Connect the fan wiring to terminals J21, J22, or J23 (depending on the inverter model) on the main circuit board.
3. Put the mounting plate in position on the top of the inverter housing and secure it with screws.
4. Replace the upper and lower front panel covers on the inverter and secure them with screws.

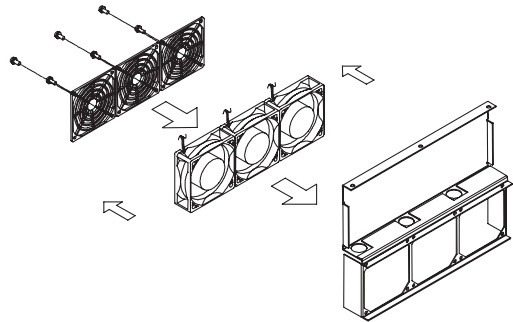

General Inverter Electrical Measurements

The following table specifies how to measure key system electrical parameters. The diagrams on the next page show inverter-motor systems and the location of measurement points for these parameters.

Parameter	Circuit location of measurement	Measuring instrument	Notes	Reference Value
Supply voltage E_1	E_R – across L1 and L2 E_S – across L2 and L3 E_T – across L3 and L1	Moving-coil type voltmeter or rectifier type voltmeter	Fundamental wave effective value	Commercial supply voltage (200V class) 200-240V, 50/60 Hz 400V class 380-460V, 50/60 Hz
Supply current I_1	I_R – L1, I_S – L2, I_T – L3	Moving-coil type ammeter	Total effective value	—
Supply power W_1	W_{11} – across L1 and L2 W_{12} – across L2 and L3	Electronic type wattmeter	Total effective value	—
Supply power factor Pf_1	$Pf_1 = \frac{W_1}{\sqrt{3} \times E_1 \times I_1} \times 100\%$			—
Output voltage E_0	E_U – across U and V E_V – across V and W E_W – across W and U	Rectifier type voltmeter	Total effective value	—
Output current I_0	I_U – U I_V – V I_W – W	Moving-coil type ammeter	Total effective value	—
Output power W_0	W_{01} – across U and V W_{02} – across V and W	Electronic type wattmeter	Total effective value	—
Output power factor Pf_0	Calculate the output power factor from the output voltage E, output current I, and output power W. $Pf_0 = \frac{W_0}{\sqrt{3} \times E_0 \times I_0} \times 100\%$			—

Note 1: Use a meter indicating a fundamental wave effective value for voltage, and meters indicating total effective values for current and power.

Note 2: The inverter output has a distorted waveform, and harmonic frequencies may cause erroneous readings. However, the measuring instruments and methods listed above provide reasonably accurate results.

Note 3: A general-purpose digital volt meter (DVM) is not usually suitable to measure a distorted waveform (not pure sinusoid).

The figure below shows measurement locations for voltage, current, and power measurements listed in the table on the previous page. The voltage to be measured is the fundamental wave effective voltage. The power to be measured is the total effective power.

Three-phase measurement diagram

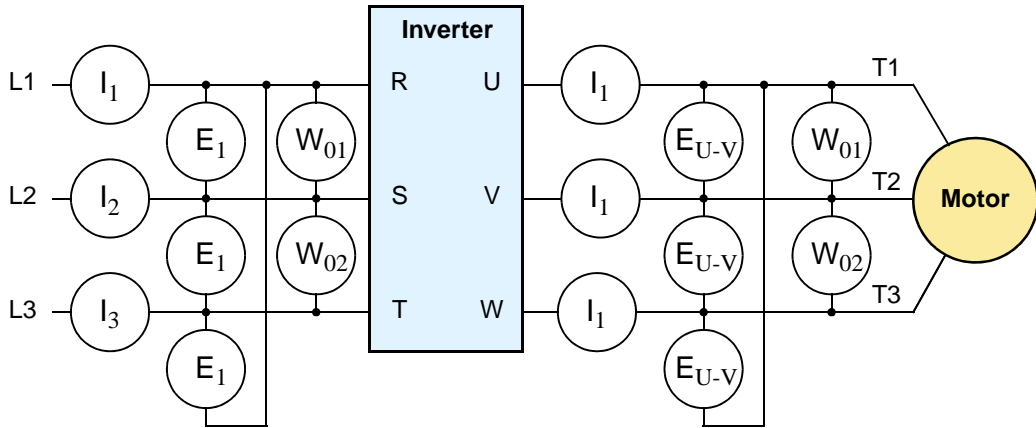

Inverter Output Voltage Measurement Techniques

Taking voltage measurements around drives equipment requires the right equipment and a safe approach. You are working with high voltages and high-frequency switching waveforms that are not pure sinusoids. Digital voltmeters will not usually produce reliable readings for these waveforms. And, it is usually risky to connect high voltage signals to oscilloscopes. The inverter output semiconductors have some leakage, and no-load measurements produce misleading results. So, we highly recommend using the following circuits to measure voltage for performing the equipment inspections.

Voltage measurement *with load*

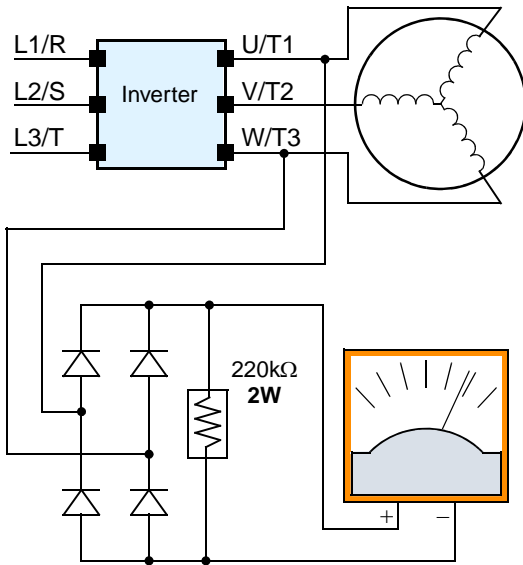

V class	Diode bridge	Voltmeter
200V class	600V 0.01A min.	300V range
400V class	1000V 0.1 A min.	600V range

Voltage measurement *without load*

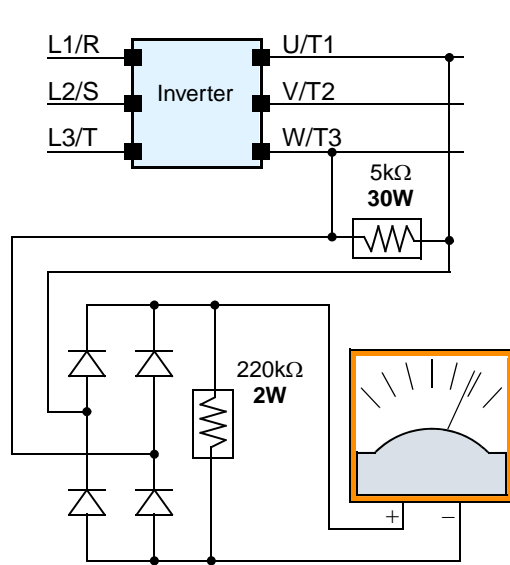

V class	Diode bridge	Voltmeter
200V class	600V 0.01A min.	300V range
400V class	1000V 0.1 A min.	600V range



HIGH VOLTAGE: Be careful not to touch wiring or connector terminals when working with the inverters and taking measurements. Be sure to place the measurement circuitry above in an insulated housing before using them.

Troubleshooting and Maintenance

IGBT Test Method

The following procedure will check the power module, including inverter transistors (IGBTs), IPM, diodes, and thyrister until replacement of inverter (1,000,000 start/stop cycles):

1. Disconnect input power to terminals [R, S, and T] and motor terminals [U, V, and W].
2. Disconnect any wires from terminals [P] and [RB] for regenerative braking.
3. Use a Digital Volt Meter (DVM) and set it for 1 ohm resistance range. You can check the status of the charging state of terminals [R, S, T, U, V, W, RB, P, and N] of the inverter and the probe of the DVM by measuring the charging state.

Almost infinite ohms = “non-conducting,” and 0 to 10 ohms = “conducting.”



NOTE: The resistance values for the diodes or the transistors will not be exactly the same, but they will be close. If you find a significance difference, a problem may exist.



NOTE: Before measuring the voltage between [P] and [N] with the DC current range, confirm that the smoothing capacitor is discharged fully, then execute the tests.

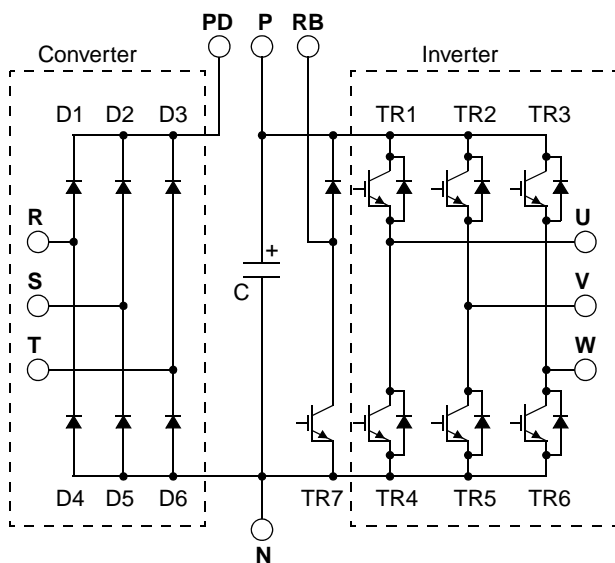

Circuit Type		DVM Probe		Measured Value
		+	-	
Converter	D1	R	PD	Non-conducting
		PD	R	Conducting
	D2	S	PD	Non-conducting
		PD	S	Conducting
	D3	T	PD	Non-conducting
		PD	T	Conducting
	D4	R	N	Conducting
		N	R	Non-conducting
	D5	S	N	Conducting
		N	S	Non-conducting
	D6	T	N	Conducting
		N	T	Non-conducting
Inverter	TR1	U	P	Non-conducting
		P	U	Conducting
	TR2	V	P	Non-conducting
		P	V	Conducting
	TR3	W	P	Non-conducting
		P	W	Conducting
	TR4	U	N	Conducting
		N	U	Non-conducting
	TR5	V	N	Conduct
		N	V	Non-conducting
	TR6	W	N	Conducting
		N	W	Non-conducting

Circuit Type		DVM Probe		Measured Value
		+	-	
Dynamic Braking (0.4kW-11kW)	TR7	RB	P	Non-conducting
		P	RB	Conducting
		RB	N	Non-conducting
		N	RB	Non-conducting

Warranty

Warranty Terms

The warranty period under normal installation and handling conditions shall be two (2) years from the date of manufacture ("DATE" on product nameplate), or one (1) year from the date of installation, whichever occurs first. The warranty shall cover the repair or replacement, at Hitachi's sole discretion, of ONLY the inverter that was installed.

1. Service in the following cases, even within the warranty period, shall be charged to the purchaser:
 - a. Malfunction or damage caused by mis-operation or modification or improper repair
 - b. Malfunction or damage caused by a drop after purchase and transportation
 - c. Malfunction or damage caused by fire, earthquake, flood, lightning, abnormal input voltage, contamination, or other natural disasters
2. When service is required for the product at your work site, all expenses associated with field repair shall be charged to the purchaser.
3. Always keep this manual handy; please do not lose it. Please contact your Hitachi distributor to purchase replacement or additional manuals.



Glossary and Bibliography

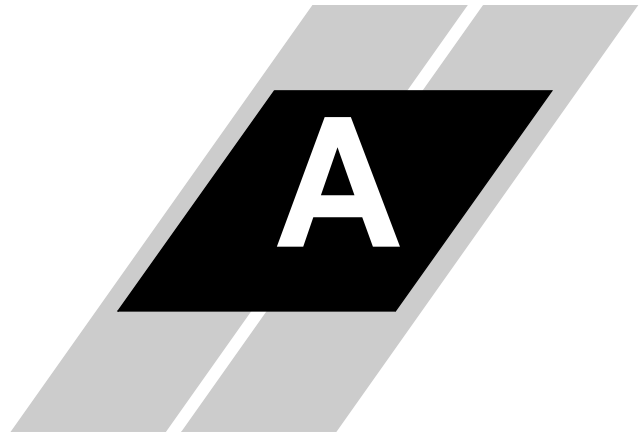

In This Appendix....	page
— Glossary	2
— Bibliography	6

Glossary

- Ambient Temperature** The air temperature in the chamber containing a powered electronic unit. A unit's heat sinks rely on a lower ambient temperature in order to dissipate heat away from sensitive electronics.
- Arrival Frequency** The arrival frequency refers to the set output frequency of the inverter for the constant speed setting. The arrival frequency feature turns ON an output when the inverter reaches the set constant speed. The inverter has various arrival frequencies and pulsed or latched logic options.
- Auto-tuning** The ability of a controller to execute a procedure that interacts with a load to determine the proper coefficients to use in the control algorithm. Auto-tuning is a common feature of process controllers with PID loops. Hitachi inverters feature auto-tuning to determine motor parameters for optimal commutation. Auto-tuning is available as a special command from a digital operator panel. See also *digital operator panel*.
- Base Frequency** The power input frequency for which an AC induction motor is designed to operate. Most motors will specify a 50 to 60 Hz value. The Hitachi inverters have a programmable base frequency, so you must ensure that parameter matches the attached motor. The term *base frequency* helps differentiate it from the carrier frequency. See also *carrier frequency* and *frequency setting*.
- Braking Resistor** An energy-absorbing resistor that dissipates energy from a decelerating load. Load inertia causes the motor to act as a generator during deceleration. See also *four-quadrant operation* and *dynamic braking*.
- Break-away Torque** The torque a motor must produce to overcome the static friction of a load in order to start the load moving.
- Carrier Frequency** The frequency of the constant, periodic, switching waveform that the inverter modulates to generate the AC output to the motor. See also *PWM*.
- CE** A regulatory agency for governing the performance of electronic products in Europe. Drive installations designed to have CE approval must have particular filter(s) installed in the application.
- Choke** An inductor that is tuned to react at radio frequencies is called a "choke," since it attenuates (chokes) frequencies above a particular threshold. Tuning is often accomplished by using a movable magnetic core. In variable-frequency drive systems, a choke positioned around high-current wiring can help attenuate harmful harmonics and protect equipment. See also *harmonics*.
- DC Braking** The inverter DC braking feature stops the AC commutation to the motor, and sends a DC current through the motor windings in order to stop the motor. Also called "DC injection braking," it has little effect at high speed, and is used as the motor is nearing a stop.
- DC Link** The portion of the variable frequency drive between the input rectifiers and the output stages. It delivers smoothed DC power to the control and output stages of the drive.
- Deadband** In a control system, the range of input change for which there is no perceptible change in the output. In PID loops, the error term may have a deadband associated with it. Deadband may or may not be desirable; it depends on the needs of the application.
- Digital Operator Panel** For Hitachi inverters, "digital operator panel" (DOP) refers first to the operator keypad on the front panel of the inverter. It also includes hand-held remote keypads, which connect to the inverter via a cable. Finally, the DOP Professional is a PC-based software simulation of the keypad devices.

Diode	A semiconductor device that has a voltage-current characteristic that allows current to flow only in one direction, with negligible leakage current in the reverse direction. See also <i>rectifier</i> .
Duty Cycle	1. The percent of time a square wave of fixed frequency is ON (high) versus OFF (low). 2. The ratio of operating time of a motor, braking resistor, etc. to its resting time. This parameter usually is specified in association with the allowable thermal rise for the device.
Dynamic Braking	The inverter dynamic braking feature shunts the motor-generated EMF energy into a special braking resistor. The added dissipation (braking torque) is effective at higher speeds, having a reduced effect as the motor nears a stop.
Error	In process control, the error is the difference between the desired value or setpoint (SP) and the actual value of a the process variable (PV). See also <i>process variable</i> and <i>PID Loop</i> .
EMI	Electromagnetic Interference - In motor/drive systems, the switching of high currents and voltages creates the possibility of generating radiated electrical noise that may interfere with the operation of nearby sensitive electrical instruments or devices. Certain aspects of an installation, such as long motor lead wire lengths, tend to increase the chance of EMI. Hitachi provides accessory filter components you can install to decrease the level of EMI.
Four-quadrant operation	Referring to a graph of torque versus speed, a four-quadrant drive can turn the motor either forward or reverse, as well as decelerate in either direction (see also <i>reverse torque</i>). A load that has a relatively high inertia and must move in both directions and change directions rapidly requires four-quadrant capability from its drive.
Free-run Stop	A method of stopping a motor, caused when the inverter simply turns OFF its motor output connections. This may allow the motor and load to coast to a stop, or a mechanical brake may intervene and shorten the deceleration time.
Frequency Setting	While frequency has a broad meaning in electronics, it typically refers to motor speed for variable-frequency drives (inverters). This is because the output frequency of the inverter is variable, and is proportional to the attained motor speed. For example, a motor with a base frequency of 60 Hz can be speed controlled with an inverter output varying from 0 to 60 Hz. See also <i>base frequency</i> , <i>carrier frequency</i> , and <i>slip</i> .
Harmonics	A <i>harmonic</i> is a whole number multiple of a base of fundamental frequency. The square waves used in inverters produce high-frequency harmonics, even though the main goal is to produce lower-frequency sine waves. These harmonics can be harmful to electronics (including motor windings) and cause radiated energy that interferes with nearby electronic devices. Chokes, line reactors, and filters are sometimes used to suppress the transmission of harmonics in an electrical system. See also <i>choke</i> .
Horsepower	A unit of physical measure to quantify the amount of work done per unit of time. You can directly convert between horsepower and Watts as measurements of power.
IGBT	Insulated Gate Bipolar Transistor (IGBT) - A semiconductor transistor capable of conducting very large currents when in saturation and capable of withstanding very high voltages when it is OFF. This high-power bipolar transistor is the type used in Hitachi inverters.
Inertia	The natural resistance of an object to being accelerated or decelerated by an external force. See also <i>momentum</i> .
Intelligent Terminal	A configurable input or output logic function on the Hitachi inverters. Each terminal may be assigned one of several functions.
Inverter	A device that electronically changes DC to AC current through a alternating process of switching the input to the output, inverted and non-inverted. A variable speed drive such as the Hitachi SJ7002 is also called an inverter, since it contains three inverter circuits to generate 3-phase output to the motor.

Isolation Transformer	A transformer with 1:1 voltage ratio that provides electrical isolation between its primary and secondary windings. These are typically used on the power input side of the device to be protected. An isolation transformer can protect equipment from a ground fault or other malfunction of nearby equipment, as well as attenuate harmful harmonics and transients on the input power.
Jogging Operation	Usually done manually, a jog command from an operator's panel requests the motor/drive system to run indefinitely in a particular direction, until the machine operator ends the jog operation.
Jump Frequency	A jump frequency is a point on the inverter output frequency range that you want the inverter to skip around. This feature may be used to avoid a resonant frequency, and you can program up to three jump frequencies in the inverter.
Line Reactor	A three-phase inductor generally installed in the AC input circuit of an inverter to minimize harmonics and to limit short-circuit current.
Momentum	The physical property of a body in motion that causes it to continue to remain in motion. In the case of motors, the rotor and attached load are rotating and possess angular momentum.
Multi-speed Operation	The ability of a motor drive to store preset discrete speed levels for the motor, and control motor speed according to the currently selected speed preset. The Hitachi inverters have 16 preset speeds.
Motor Load	In motor terminology, motor load consists of the inertia of the physical mass that is moved by the motor and the related friction from guiding mechanisms. See also <i>inertia</i> .
NEC	The National Electric Code is a regulatory document that governs electrical power and device wiring and installation in the United States.
NEMA	The National Electric Manufacturer's Association. NEMA Codes are a published series of device ratings standards. Industry uses these to evaluate or compare the performance of devices made by various manufacturers to a known standard.
Open-collector Outputs	A common logic-type discrete output that uses an NPN transistor that acts as a switch to a power supply common, usually ground. The transistor's <i>collector</i> is <i>open</i> for external connection (not connected internally). Thus, the output <i>sinks</i> external load current to ground.
Orientation	When using the expansion card SJ-FB with encoder feedback, the orientation feature is available. Also called <i>home search</i> in motion terminology, you can specify a search direction and a stop position. Typically the orientation procedure is necessary after each inverter powerup.
Power Factor	A ratio that expresses a phase difference (timing offset) between current and voltage supplied by a power source to a load. A perfect power factor = 1.0 (no phase offset). Power factors less than one cause some energy loss in power transmission wiring (source to load).
PID Loop	Proportional-Integral-Derivative – a mathematical model used for process control. A process controller maintains a process variable (PV) at a setpoint (SP) by using its PID algorithm to compensate for dynamic conditions and varies its output to drive the PV toward the desired value. See also <i>error</i> .
Process Variable	A physical property of a process that is of interest because it affects the quality of the primary task accomplished by the process. For an industrial oven, temperature is the process variable. See also <i>PID Loop</i> and <i>error</i> .
PWM	Pulse-width modulation: A type of AC adjustable frequency drive that accomplishes frequency and voltage control at the output section (inverter) of the drive. The drive output voltage waveform is at a constant amplitude, and by "chopping" the waveform (pulse-width-modulating), the average voltage is controlled. The chopping frequency is sometimes called the <i>carrier frequency</i> .

Reactance	The impedance of inductors and capacitors has two components. The resistive part is constant, while the reactive part changes with applied frequency. These devices have a complex impedance (complex number), where the resistance is the real part and the reactance is the imaginary part.
Rectifier	An electronic device made of one or more diodes that converts AC power into DC power. Rectifiers are usually used in combination with capacitors to filter (smooth) the rectified waveform to closely approximate a pure DC voltage source.
Regenerative Braking	A particular method of generating reverse torque to a motor, an inverter will switch internally to allow the motor to become a generator and will either store the energy internally, deliver the braking energy back to the main power input, or dissipate it with a resistor.
Regulation	The quality of control applied to maintain a parameter of interest at a desired value. Usually expressed as a percent (+/-) from the nominal, motor regulation usually refers to its shaft speed.
Reverse Torque	The torque applied in the direction opposite to motor shaft rotation. As such, reverse torque is a decelerating force on the motor and its external load.
Rotor	The windings of a motor that rotate, being physically coupled to the motor shaft. See also <i>stator</i> .
Saturation Voltage	For a transistor semiconductor device, it is in saturation when an increase in input current no longer results in an increase in the output current. The saturation voltage is the voltage drop across the device. The ideal saturation voltage is zero.
Sensorless Vector Control	A technique used in variable-frequency drives to rotate the force vector in the motor without the use of a shaft position sensor (angular). Benefits include an increase in torque at the lowest speed and the cost savings from the lack of a shaft position sensor.
Setpoint (SP)	The setpoint is the desired value of a process variable of interest. See also <i>Process Variable (PV)</i> and <i>PID Loop</i> .
Single-phase Power	An AC power source consisting of Hot and Neutral wires. An Earth Ground connection usually accompanies them. In theory, the voltage potential on Neutral stays at or near Earth Ground, while Hot varies sinusoidally above and below Neutral. This power source is named Single Phase to differentiate it from three-phase power sources. Some Hitachi inverters can accept single phase input power, but they all output three-phase power to the motor. See also <i>three-phase</i> .
Slip	The difference between the theoretical (synchronous) speed of a motor at no load (determined by its inverter output waveforms) and the actual speed. Some slip is essential in order to develop torque to the load, but too much will cause excessive heat in the motor windings and/or cause the motor to stall.
Squirrel Cage	A “nick-name” for the appearance of the rotor frame assembly for an AC induction motor.
Stator	The windings in a motor that are stationary and coupled to the power input of the motor. See also <i>rotor</i> .
Start Frequency	The output frequency that the inverter first produces as the frequency command setting increases from zero. The start frequency is programmable, and is important to set properly for the load, etc.
Tachometer	1. A signal generator usually attached to the motor shaft for the purpose of providing feedback to the speed controlling device of the motor. 2. A speed-monitoring test meter that may optically sense shaft rotation speed and display it on a readout.

Thermal Switch

An electromechanical safety device that opens to stop current flow when the temperature at the device reaches a specific temperature threshold. Thermal switches are sometimes installed in the motor in order to protect the windings from heat damage. The inverter can use thermal switch signals to trip (shut down) if the motor overheats. See also *trip*.

Thermistor

A type of temperature sensor that changes its resistance according to its temperature. The sensing range of thermistors and their ruggedness make them ideal for motor overheating detection. Hitachi inverters have built-in thermistor input circuits, which can detect an overheated motor and shut OFF (trip) the inverter output.

Three-phase Power

An AC power source with three Hot connections that have phase offsets of 120 degrees is a 3-phase power source. Usually, Neutral and Earth Ground wires accompany the three Hot connections. Loads may be configured in a delta or Y configuration. A Y-connected load such as an AC induction motor will be a balanced load; the currents in all the Hot connections are the same. Therefore, the Neutral connection is theoretically zero. This is why inverters that generate 3-phase power for motors do not generally have a Neutral connection to the motor. However, the Earth Ground connection is important for safety reasons, and is provided.

Torque

A measure of rotational force. The units of measurement are the product of the distance (radius from shaft center axis) and force (weight) applied at that distance. Units are usually given as pound-feet, ounce-inches, or Newton-meters.

Transistor

A solid state, three-terminal device that provides amplification of signals and can be used for switching and control. While transistors have a linear operating range, inverters use them as high-powered switches. Recent developments in power semiconductors have produced transistors capable of handling high voltages and currents, all with high reliability. The saturation voltage has been decreasing, resulting in less heat dissipation. Hitachi inverters use state-of-the-art semiconductors to provide high performance and reliability in a compact package. See also *IGBT* and *saturation voltage*.

Trip

An event that causes the inverter to stop operation is called a “trip” event (as in *tripping* a circuit breaker). The inverter keeps a history log of trip events. They also require an action to clear.

Watt Loss

A measure of the internal power loss of a component, the difference between the power it consumes and what its output delivers. An inverter’s watt loss is the input power minus the power delivered to the motor. The watt loss is typically highest when an inverter is delivering its maximum output. Therefore, watt loss is usually specified for a particular output level. Inverter watt loss specifications are important when designing enclosures.

Bibliography

Title	Author and Publisher
Variable Speed Drive Fundamentals, 2nd Ed.	Phipps, Clarence A. The Fairmont Press, Inc. / Prentice-Hall, Inc. 1997 ISBN 0-13-636390-3
Electronic Variable Speed Drives	Brumbach, Michael E. Delmar Publishers 1997 ISBN 0-8273-6937-9
Hitachi Inverter Technical Guide Book	Published by Hitachi, Ltd. Japan 1995 Publication SIG-E002

Serial Communications

**B**

In This Appendix....	page
— Introduction	2
— ASCII Mode Communications	5
— Communications Reference Information	18
— ModBus Mode Communications	21
— ModBus Data Listing	33

Introduction

SJ7002 inverters have a built-in RS485 serial communications interface. This serial communications function provides a way of controlling from 1 to 32 inverters on a common serial network. SJ7002, SJ300, and L300P inverters all have the same communications protocol. In a typical application, a host computer or controller is the master and each of the inverter(s) is a slave, as shown in the figure below.

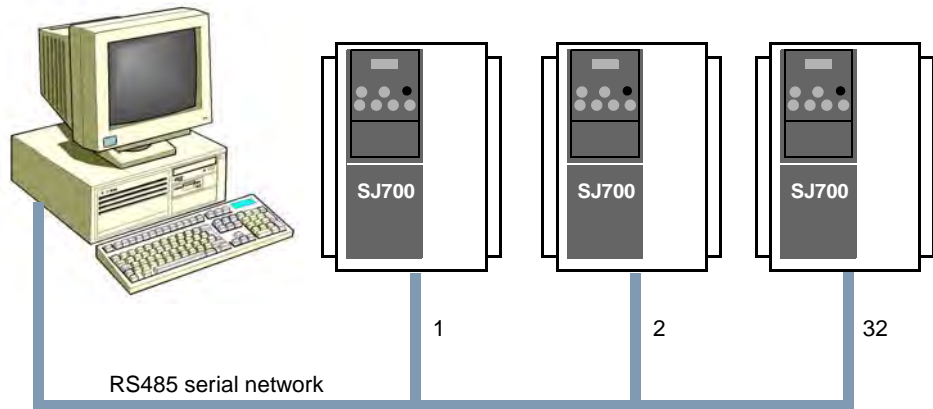

The specifications for SJ7002 Series RS485 serial communications are in the following table:

Item	ASCII Mode	ModBus RTU mode	User-selectable
Transmission speed	2400 / 4800 / 9600 / 19200 bps		✓
Communication modes	Half duplex (one device transmits at a time)		✗
Synchronization	Start/stop transmission	Asynchronous transmission	✗
Character code	ASCII code	Binary code	✗
LSB placement	Transmits LSB first		✗
Electrical interface	RS485 differential transceiver		✗
Data bits	7 or 8 bits	8 bits	✓
Parity	None / even / odd		✓
Stop bits	1 or 2 bits		✓
Start convention	One-way start only by command from host device on network		✗
Wait time for response	10 to 1,000 ms	0 to 1,000 ms	✓
Connection format	Station address numbers from 1 to 32 maximum		✓
Error check	Overrun, framing, BCC, vertical parity, and longitudinal parity errors	Overrun, framing, CRC-16, and longitudinal parity errors	✗

Serial Connection Diagrams

The serial connector is to the left of the control logic connector as shown below:

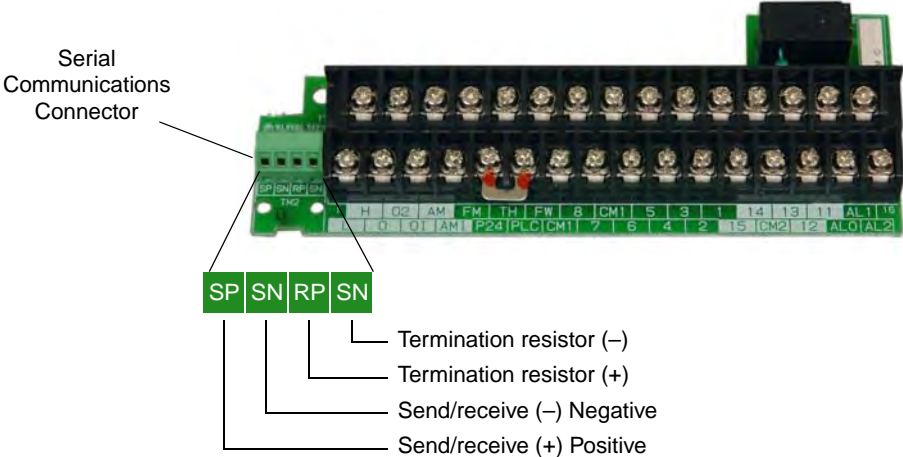

Appendix B

Each device requires just two connections in parallel for data transmission and reception. Additionally, the device at each physical end of the wiring requires a termination resistor. The SJ7002 has built-in termination resistors that become part of the circuit when you add a jumper as shown. The termination resistor helps to suppress electrical reflections.

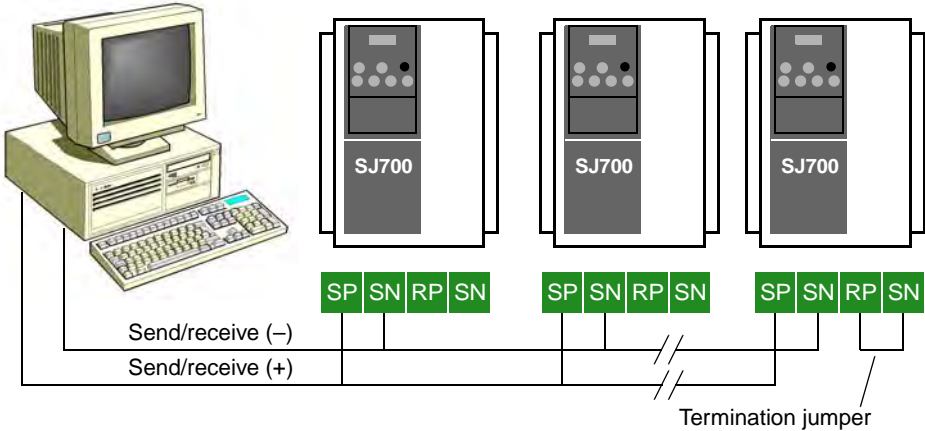

TIP: Each slave device on the serial network must have a unique node address, set by parameter C072. If this is a new application, we recommend connecting one new device at a time and checking the communications after each addition.

Serial Network Parameter Settings

Several parameter settings are necessary to configure serial communications, listed below.

Function Code	Item	Value	Description
C071	Baud rate	02	Loop-back test
		03	2400 bps
		04	4800 bps
		05	9600 bps
		06	19200 bps
C072	Node address	1 to 32, FF	1 to 32 – Node or station address (unique to each inverter or device) FF – Automatic broadcast (to all nodes on transmit, allowed only on certain commands (refer to each command description in this appendix)
C073	Data bits	07	7 bits
		08	8 bits
C074	Parity	00	none
		01	Even parity
		02	Odd parity
C075	Stop bits	01	1 bit
		02	2 bits
C078	Wait time	0 to 1000	0 to 1000 ms time that the inverter waits to respond to network master
C079	Communication protocol select	00	ASCII
		01	ModBus RTU

For inverters on the same network, some settings must match from inverter to inverter. These include: Baud rate, data bits, parity, and stop bits. However, the node address on each inverter must be unique, used only once on the network.

Communication Test Mode

Use the communication test mode to check the RS485 serial port hardware on the inverter. Use the following procedure:

1. Disconnect the wiring from the TM2 serial port terminal block on the inverter.
2. Set parameter C071 = 02 (loopback test)
3. Turn the inverter power OFF and then ON again to initiate the communication test.
4. Check the pass/fail results according to the keypad display.



Normal termination



Abnormal termination

5. Press the STOP/RESET key on the digital operator keypad (or the Reset button on the copy unit) to switch to the normal setting display.
6. Set parameter C071 to the desired setting for normal operation.

ASCII Mode Communications

Introduction to Command List

The network master sends a frame to initiate communications with a slave, as shown in the figure to the right. After the set waiting time (per parameter C078, the inverter responds.

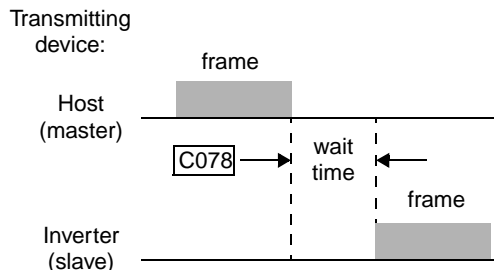

The following table lists the commands (single-character codes) sent to a particular device on the network. Some commands may be broadcast to all devices on the network.

Command Code	Description	Broadcast to all devices
00	Forward / Reverse / Stop command	✓
01	Setting of frequency in standard profile	✓
02	Setting of intelligent terminal state	✓
03	Read all monitor data (block read)	—
04	Read inverter status	—
05	Read trip history	—
06	Read a single parameter value	—
07	Write a single parameter value	✓
08	Set inverter parameters to default values	✓
09	Verifies that the requested setting can be written to EEPROM.	—
0A	Writes a parameter value to EEPROM	✓
0B	Requests the recalculation of internal constant	✓



NOTE: Use of command 08 – set inverter parameters to default values first requires setting the initialization mode parameter B084 to 01 (initializes parameters only) or 02 (initializes parameters and clears the trip history).

Command – 00

The 00 command controls the Forward, Reverse, and Stop mode of the inverter. You must set parameter A002=03 in order for serial communications control of the inverter to apply.

The frame format of command 00 follows the timing diagram and specification table.

Frame format

STX	Node	Command	Data	BCC	[CR]
-----	------	---------	------	-----	------

Element	Description	Size	Value
STX	Control code (S T art of Te X t)	1 byte	STX (0x02)
Node	Node (station) address of inverter	2 bytes	01 to 32, and FF (broadcast to all nodes)
Command	Transmission command	2 bytes	00
Data	Transmission data	1 byte	00 = Stop command 01 = Forward command 02 = Reverse command
BCC	Block check sum code	2 bytes	Exclusive OR of Node, Command, and Data
[CR]	Control code (carriage return)	1 byte	[CR] (0x0D)

The example below shows a transmission to the inverter at address Node 1 to rotate the motor in the forward direction.

(STX) | 01 | 00 | 1 | (BCC) | [CR] $\xrightarrow{\text{to ASCII}}$ 02 | 30 31 | 30 30 | 31 | 33 30 | 0D

Command – 01

The 01 command sets the output frequency for the standard profile. You must set parameter A002=03 in order for serial communications control of the inverter to apply.

The frame format of command 01 follows the **Frame format** timing diagram and specification table.

STX	Node	Command	Data	BCC	[CR]
-----	------	---------	------	-----	------

Element	Description	Size	Value
STX	Control code (S T art of Te X t)	1 byte	STX (0x02)
Node	Node (station) address of inverter	2 bytes	01 to 32, and FF (broadcast to all nodes)
Command	Transmission command	2 bytes	01
Data	Transmission data	6 bytes	ASCII code for ten times the frequency (accommodates two decimal places)
BCC	Block check sum code	2 bytes	Exclusive OR of Node, Command, and Data
[CR]	Control code (carriage return)	1 byte	[CR] (0x0D)

The example below shows a transmission to the inverter at address Node 1 to set the output frequency for 5 Hz. We use a value of 500 in ASCII to represent 5.00 Hz.

(STX) | 01 | 01 | 000500 | (BCC) | [CR]
 $\xrightarrow{\text{to ASCII}}$ 02 | 30 31 | 30 31 | 30 30 30 35 30 30 | 30 35 | 0D

When using the data as the feedback (process variable) for PID control, set the most significant byte to ASCII "1." The following example transmits the data "5%."

(STX) | 01 | 01 | 000500 | (BCC) | [CR]
 $\xrightarrow{\text{to ASCII}}$ 02 | 30 31 | 30 31 | 31 30 30 35 30 30 | 30 35 | 0D

**Commands –
02 and 12**

The 02 command sets the logic state (ON or OFF) of the intelligent input terminals.

The frame format of command 02 follows the timing diagram and specification table. Frame format

STX	Node	Command	Data	BCC	[CR]
-----	------	---------	------	-----	------

Element	Description	Size	Value
STX	Control code (S T art of Te X t)	1 byte	STX (0x02)
Node	Node (station) address of inverter	2 bytes	01 to 32, and FF (broadcast to all)
Command	Transmission command	2 bytes	02 or 12
Data	Transmission data	16 bytes	(see tables below)
BCC	Block check sum code	2 bytes	Exclusive OR of Node, Command, and Data
[CR]	Control code (carriage return)	1 byte	[CR] (0x0D)

The 16-byte data string is specified in the following tables:

Data (Hex)	02 Command Description	Data (Hex)	02 CommandDescription
0000000000000001	[FW] Forward command	0000000100000000	[SF1] Multi-speed bit-level
0000000000000002	[RV] Reverse command	0000000200000000	[SF2] Multi-speed bit-level
0000000000000004	[CF1] Multi-speed 1	0000000400000000	[SF3] Multi-speed bit-level
0000000000000008	[CF2] Multi-speed 2	0000000800000000	[SF4] Multi-speed bit-level
0000000000000010	[CF3] Multi-speed 3	0000001000000000	[SF5] Multi-speed bit-level
0000000000000020	[CF4] Multi-speed 4	0000002000000000	[SF6] Multi-speed bit-level
0000000000000040	[JG] Jog operation	0000004000000000	[SF7] Multi-speed bit-level
0000000000000080	[DB] Dynamic braking	0000008000000000	[OLR] Overload restriction setting
0000000000000100	[SET] set 2nd motor	0000010000000000	[TL] Torque limit
0000000000000200	[2CH] 2-stage adjustable speed	0000020000000000	[TRQ1] Torque limit select 1
0000000000000400	—	0000040000000000	[TRQ2] Torque limit select 2
0000000000000800	[FRS] Free-run stop	0000080000000000	[PPI P/PI] inverter mode select
0000000000001000	[EXP] External trip	0000100000000000	[BOK] Brake confirmation
0000000000002000	[USP] Unattended start protection	0000200000000000	[ORT] Orientation (home) command
0000000000004000	[CS] Commercial power change	0000400000000000	[LAC] Linear Accel/decel Cancel
0000000000008000	[SFT] Software lock	0000800000000000	[PCLR] Position error clear
0000000000010000	[AT] analog input voltage/current	0001000000000000	[STAT] Pulse train input enable
0000000000020000	[SET3] Set 3rd motor	0002000000000000	—
0000000000040000	[RS] Reset	0004000000000000	[ADD] Trigger for frequency addition
0000000000080000	—	0008000000000000	[F-TM] Forcible terminal operation
0000000000100000	[STA] 3-wire Start	0010000000000000	[ATR] Permission of torque command
0000000000200000	[STP] 3-wire Hold	0020000000000000	[KHC] Cumulative power clearance
0000000000400000	[F/R] 3-wire FWD/REV	0040000000000000	[SON] Servo ON
0000000000800000	[PID] PID enable	0080000000000000	[FOC] Forcing
0000000001000000	[PIDC] PID integrator reset	0100000000000000	[MI1] General-purpose input 1
0000000002000000	—	0200000000000000	[MI2] General-purpose input 2

Data (Hex)	02 Command Description	Data (Hex)	02 CommandDescription
000000004000000	[CAS] control gain switching function	0400000000000000	[MI3] General-purpose input 3
000000008000000	[UP] remote control increment speed	0800000000000000	[MI4] General-purpose input 4
000000010000000	[DWN] remote control decrement speed	1000000000000000	[MI5] General-purpose input 5
000000020000000	[UDC] remote control clear up/down	2000000000000000	[MI6] General-purpose input 6
000000040000000	[OPE] Forcible operation	4000000000000000	[MI7] General-purpose input 7
000000080000000	—	8000000000000000	[MI8] General-purpose input 8

Data (Hex)	12 Command Description	Data (Hex)	12 CommandDescription
0000000000000001	—	0000001000000000	—
0000000000000002	[AHD] Analog command holding	0000002000000000	—
0000000000000004	[CP1] Multi-stage position select 1	0000004000000000	—
0000000000000008	[CP2] Multi-stage position select 2	0000008000000000	—
0000000000000010	[CP3] Multi-stage position select 3	0000010000000000	—
0000000000000020	[ORL] Zero-return limit function	0000020000000000	—
0000000000000040	[ORG] Zero-return trigger function	0000040000000000	—
0000000000000080	[FOT] Forward drive stop	0000080000000000	—
0000000000000100	[ROT] Reverse drive stop	0000100000000000	—
0000000000000200	[SPD] Speed / position switching	0000200000000000	—
0000000000000400	[PCNT] Pulse counter	0000400000000000	—
0000000000000800	[PCC] Pulse counter clear	0000800000000000	—
0000000000001000	—	0001000000000000	—
0000000000002000	—	0002000000000000	—
0000000000004000	—	0004000000000000	—
0000000000008000	—	0008000000000000	—
0000000000010000	—	0010000000000000	—
0000000000020000	—	0020000000000000	—
0000000000040000	—	0040000000000000	—
0000000000080000	—	0080000000000000	—
0000000001000000	—	0100000000000000	—
0000000002000000	—	0200000000000000	—
0000000004000000	—	0400000000000000	—
0000000008000000	—	0800000000000000	—
0000000010000000	—	1000000000000000	—
0000000020000000	—	2000000000000000	—
0000000040000000	—	4000000000000000	—
0000000080000000	—	8000000000000000	—

The arrangement of the terminal assignment data permits you to assign all inputs in a single command. The example below shows a transmission to the inverter at address Node 1 to set the Forward command, Multi-speed 1 and Multi-speed 2.

Sum the three data strings:
 0x0000000000000001
 + 0x0000000000000004
 + 0x0000000000000008
 = 0x000000000000000D

(STX) | 01 | 02 | 0x000000000000000D | (BCC) | (CR) $\xrightarrow{\text{to ASCII}}$
 02 | 30 31 | 30 31 | 30 30 30 30 30 30 30 30 30 30 30 30 30 30 30 30 68 | 30 35 | 0D

Command – 03

The 03 command reads the monitor data as a single block.

The frame format of command 03 follows the diagram and specification table. The transmit frame has no data field.

Transmit frame format

STX	Node	Command	BCC	[CR]
-----	------	---------	-----	------

Element	Description	Size	Value
STX	Control code (S T art of Te X t)	1 byte	STX (0x02)
Node	Node (station) address of inverter	2 bytes	01 to 32
Command	Transmission command	2 bytes	03
BCC	Block check sum code	2 bytes	Exclusive OR of Node, Command, and Data
[CR]	Control code (carriage return)	1 byte	[CR] (0x0D)

The receive frame has a 104-byte data field, containing values for 13 items.

Receive frame format

STX	Node	Data	BCC	[CR]
-----	------	------	-----	------

Element	Description	Size	Value
STX	Control code (S T art of Te X t)	1 byte	STX (0x02)
Node	Node (station) address of inverter	2 bytes	01 to 32
Data	Transmission data	104 bytes	(see next table)
BCC	Block check sum code	2 bytes	Exclusive OR of Node, Command, and Data
[CR]	Control code (carriage return)	1 byte	[CR] (0x0D)

The data in the receive frame contains 8-byte values for 13 items, listed in the table below:

No.	Monitor Item	Units	Multiplier	Data Size	Notes
1	Output frequency	Hz	100	8 bytes	Dec. ASCII code
2	Output current	A	10	8 bytes	Dec. ASCII code
3	Direction of rotation	—	—	8 bytes	0 = Stop 1 = FWD 2 = REV
4	PID feedback monitor	%	100	8 bytes	Dec. ASCII code
5	Intelligent input monitor	—	—	8 bytes	Dec. ASCII code
6	Intelligent output monitor	—	—	8 bytes	Dec. ASCII code
7	Frequency converting monitor	—	100	8 bytes	Dec. ASCII code
8	Output torque monitor	%	1	8 bytes	Dec. ASCII code
9	Output voltage monitor	V	10	8 bytes	Dec. ASCII code
10	Electric power monitor	kW	10	8 bytes	Dec. ASCII code
11	Reserved	—	—	8 bytes	= 00000000
12	Run Mode time monitor	hours	1	8 bytes	Dec. ASCII code
13	Power ON time monitor	hours	1	8 bytes	Dec. ASCII code

The eight bytes for intelligent input or intelligent output data have a bit set in the data field for each I/O point that is ON, according to the following table:

Terminal	Monitor Item	Data
[1]	Input 1	00000001
[2]	Input 2	00000002
[3]	Input 3	00000004
[4]	Input 4	00000008
[5]	Input 5	00000010
[6]	Input 6	00000020
[7]	Input 7	00000040
[8]	Input 8	00000080
[FW]	Forward input	00000100
[11]	Output 1	00000001
[12]	Output 2	00000002
[13]	Output 3	00000003
[14]	Output 4	00000008
[15]	Output 5	00000010
[AL]	Alarm relay	00000020

Command – 04

The 04 command reads the status of the inverter. The frame format of command 04 follows the diagrams and specification tables. The transmit frame has no data field.

Transmit frame format

STX	Node	Command	BCC	[CR]
-----	------	---------	-----	------

Element	Description	Size	Value
STX	Control code (S T art of Te X t)	1 byte	STX (0x02)
Node	Node (station) address of inverter	2 bytes	01 to 32
Command	Transmission command	2 bytes	04
BCC	Block check sum code	2 bytes	Exclusive OR of Node, Command, and Data
[CR]	Control code (carriage return)	1 byte	[CR] (0x0D)

The receive frame has an 8-byte data field, containing values for three trip items (plus a reserved field).

Receive frame format

STX	Node	Data	BCC	[CR]
-----	------	------	-----	------

Element	Description	Size	Value
STX	Control code (S T art of Te X t)	1 byte	STX (0x02)
Node	Node (station) address of inverter	2 bytes	01 to 32
Data	Transmission data	8 bytes	(see next table)
BCC	Block check sum code	2 bytes	Exclusive OR of Node, Command, and Data
[CR]	Control code (carriage return)	1 byte	[CR] (0x0D)

Trip data is organized as shown. The table below lists the codes and their meanings.

Data field contents

Status A	Status B	Status C	(reserved)
----------	----------	----------	------------

Code	Status A Definition	Status B Definition	Status C Definition
00	Initial status	On stopping	—
01	—	On running	Stop
02	On Stopping	On tripping	Deceleration speed
03	On running	—	Constant speed
04	On free-run stop	—	Acceleration speed
05	On jog	—	Forward
06	On dynamic braking	—	Reverse
07	On retry	—	Reverse from forward
08	On trip	—	Forward from reverse
09	On under-voltage	—	Forward start
10	—	—	Reverse start

Command – 05

The 05 command reads the inverter’s trip history. The frame format of command 05 follows the diagrams and specification tables. The transmit frame has no data field.

Transmit frame format

STX	Node	Command	BCC	[CR]
-----	------	---------	-----	------

Element	Description	Size	Value
STX	Control code (S T art of Te X t)	1 byte	STX (0x02)
Node	Node (station) address of inverter	2 bytes	01 to 32
Command	Transmission command	2 bytes	05
BCC	Block check sum code	2 bytes	Exclusive OR of Node, Command, and Data
[CR]	Control code (carriage return)	1 byte	[CR] (0x0D)

The receive frame has a 440-byte data field. This consists of an 8-byte total accumulated number of trip events, followed by six 72-byte strings for the six most recent trip events as shown below.

Receive frame format

STX	Node	Data	BCC	[CR]
-----	------	------	-----	------

Data field contents

Total count	Trip 1	Trip 2	Trip 3	Trip 4	Trip 5	Trip 6
-------------	--------	--------	--------	--------	--------	--------

Element	Description	Size	Value
STX	Control code (S T art of Te X t)	1 byte	STX (0x02)
Node	Node (station) address of inverter	2 bytes	01 to 32
Data	Transmission data	440 bytes	(see next table)
BCC	Block check sum code	2 bytes	Exclusive OR of Node, Command, and Data
[CR]	Control code (carriage return)	1 byte	[CR] (0x0D)

The nine bytes of data for each trip event history is listed below. The data contains the multiplier to adjust the decimal point. Divide the data by that factor to derive the actual value.

No.	Monitor Item	Units	Multiplier	Data Size	Notes
1	Trip factor	—	—	8 bytes	Factor code
2	Inverter Status A	—	—	8 bytes	Same as 04 command data
3	Inverter Status B	—	—	8 bytes	
4	Inverter Status C	—	—	8 bytes	
5	Output frequency	Hz	10	8 bytes	Dec. ASCII code
6	Accumulated Run Mode time	hours	1	8 bytes	Dec. ASCII code
7	Output current	A	10	8 bytes	Dec. ASCII code
8	Output voltage	V	10	8 bytes	Dec. ASCII code
9	Power ON time	hours	1	8 bytes	Dec. ASCII code

For Command 05, bytes 2, 3, and 4 of the event history are status codes A, B, and C, respectively. The tables below provide status code descriptions.

Data field contents

	byte 2	byte 3	byte 4
	Status A	Status B	Status C

Code	Status A Definition	Status C Definition
00	Initial status	On reset
01	—	On stopping
02	On Stopping	On deceleration
03	On running	Constant speed
04	On free-run stop	On acceleration
05	On jog	On 0 Hz running
06	On dynamic braking	On running
07	On retry	On dynamic braking
08	On trip	On overload restriction
09	On under-voltage	—

Bit	Status B Definition	Error Code
0	Ground fault	E14
1	IGBT error, U phase	E30
2	Under-voltage error	E09
3	Over-voltage protection	E07
4	Thermal trip	E21
5	IGBT error, V phase	E30
6	IGBT error, W phase	E30
7	Gate array error	E23

Command – 06

The 06 command reads a single parameter value from the inverter, which is specified by the data field this read command.

Transmit frame format

STX	Node	Command	Data	BCC	[CR]
-----	------	---------	------	-----	------

Element	Description	Size	Value
STX	Control code (S T art of Te X t)	1 byte	STX (0x02)
Node	Node (station) address of inverter	2 bytes	01 to 32
Command	Transmission command	2 bytes	06
Data	Parameter specified to be read	4 bytes	(see tables below)
BCC	Block check sum code	2 bytes	Exclusive OR of Node, Command, and Data
[CR]	Control code (carriage return)	1 byte	[CR] (0x0D)

The receive frame includes an ACK (acknowledge) character, followed by an 8-byte data field.

Receive frame format

STX	Node	ACK	Data	BCC	[CR]
-----	------	-----	------	-----	------

Element	Description	Size	Value
STX	Control code (S T art of Te X t)	1 byte	STX (0x02)
Node	Node (station) address of inverter	2 bytes	01 to 32
ACK	Control code (ACKnowledge)	1 byte	ACK (0x06)
Data	Parameter value	8 bytes	Value of parameter times ten, returned as ASCII char. code, except for H003 and H203 (see table below)
BCC	Block check sum code	2 bytes	Exclusive OR of Node, Command, and Data
[CR]	Control code (carriage return)	1 byte	[CR] (0x0D)

Use the codes in the table below to return parameters for H003 and H203 (motor capacity selection).

Code Data	00	01	02	03	04	05	06	07	08	09	10
Japan or U.S.A. mode (B85 = 00 or 02)	0.2 kW	—	0.4	—	0.75	—	1.5	2.2	—	3.7	—
EU mode (B85=01)	0.2 kW	0.37	—	0.55	0.75	1.1	1.5	2.2	3.0	—	4.0
Code Data	11	12	13	14	15	16	17	18	19	20	21
Japan or U.S.A. mode (B85 = 00 or 02)	5.5 kW	7.5	11	15	18.5	22	30	37	45	55	75
EU mode (B85=01)	5.5 kW	7.5	11	15	18.5	22	30	37	45	55	75
Code Data	22	23	24	25	26	27	28	29	30	31	32
Japan or U.S.A. mode (B85 = 00 or 02)	90 kW	110	132	150	160	185	200	220	250	280	300
EU mode (B85=01)	90 kW	110	132	150	160	185	200	220	250	280	300
Code Data	33	34	35	36	—	—	—	—	—	—	—
Japan or U.S.A. mode (B85 = 00 or 02)	315 kW	340	355	400	—	—	—	—	—	—	—
EU mode (B85=01)	315 kW	340	355	400	—	—	—	—	—	—	—

Command – 07

The 07 command sets a parameter value equal to the value specified in the transmission. The frame format of command 07 follows the diagram and specification table.

Frame format

STX	Node	Command	Parameter	Data	BCC	[CR]
-----	------	---------	-----------	------	-----	------

Element	Description	Size	Value
STX	Control code (SStart of TeXt)	1 byte	STX (0x02)
Node	Node (station) address of inverter	2 bytes	01 to 32, and FF (broadcast to all nodes)
Command	Transmission command	2 bytes	07
Parameter	Function code of parameter	4 bytes	F002..., A001..., B001..., C001..., H003..., P001...
Data	Transmission data	8 bytes	Value of parameter times ten as ASCII char. code, except for H003 and H203 (see table below)
BCC	Block check sum code	2 bytes	Exclusive OR of Node, Command, and Data
[CR]	Control code (carriage return)	1 byte	[CR] (0x0D)

Note that the parameter F001, the output frequency, can be set more directly with host command 01 instead of with this command. Use the codes in the following table for setting parameters associated with H003 and H203.

Code Data	00	01	02	03	04	05	06	07	08	09	10
Japan or U.S.A. mode (B85 = 00 or 02)	0.2 kW	—	0.4	—	0.75	—	1.5	2.2	—	3.7	—
EU mode (B85=01)	0.2 kW	0.37	—	0.55	0.75	1.1	1.5	2.2	3.0	—	4.0
Code Data	11	12	13	14	15	16	17	18	19	20	21
Japan or U.S.A. mode (B85 = 00 or 02)	5.5 kW	7.5	11	15	18.5	22	30	37	45	55	75
EU mode (B85=01)	5.5 kW	7.5	11	15	18.5	22	30	37	45	55	75
Code Data	22	23	24	25	26	27	28	29	30	31	32
Japan or U.S.A. mode (B85 = 00 or 02)	90 kW	110	132	150	160	185	200	220	250	280	300
EU mode (B85=01)	90 kW	110	132	150	160	185	200	220	250	280	300
Code Data	33	34	35	36	—	—	—	—	—	—	—
Japan or U.S.A. mode (B85 = 00 or 02)	315 kW	340	355	400	—	—	—	—	—	—	—
EU mode (B85=01)	315 kW	340	355	400	—	—	—	—	—	—	—

Command – 08

The 08 command initializes the inverter parameters to the factory default values. First, you must set B84 (use command 07) to specify whether you want to clear the trip history at the same time. Also, set B85 to specify the country code for the initialization (use command 07).

The frame format of command 08 follows the diagram and specification table.

Frame format

STX	Node	Command	BCC	[CR]
-----	------	---------	-----	------

Element	Description	Size	Value
STX	Control code (STart of TeXt)	1 byte	STX (0x02)
Node	Node (station) address of inverter	2 bytes	01 to 32, and FF (broadcast to all nodes)
Command	Transmission command	2 bytes	08
BCC	Block check sum code	2 bytes	Exclusive OR of Node, Command, and Data
[CR]	Control code (carriage return)	1 byte	[CR] (0x0D)

Command – 09

The 09 command verifies whether or not it is possible to set a particular parameter in the EEPROM. The frame format of command 08 follows the diagram and specification table.

Transmit frame format

STX	Node	Command	BCC	[CR]
-----	------	---------	-----	------

Element	Description	Size	Value
STX	Control code (STart of TeXt)	1 byte	STX (0x02)
Node	Node (station) address of inverter	2 bytes	01 to 32
Command	Transmission command	2 bytes	09
BCC	Block check sum code	2 bytes	Exclusive OR of Node, Command, and Data
[CR]	Control code (carriage return)	1 byte	[CR] (0x0D)

The receive frame includes an ACK (acknowledge) character, followed by a 2-byte data field with the result.

Receive frame format

STX	Node	ACK	Data	BCC	[CR]
-----	------	-----	------	-----	------

Element	Description	Size	Value
STX	Control code (STart of TeXt)	1 byte	STX (0x02)
Node	Node (station) address of inverter	2 bytes	01 to 32
ACK	Control code (ACKnowledge)	1 byte	ACK (0x06)
Data	Parameter value	2 bytes	00 = setting not allowed, 01 = setting is allowed
BCC	Block check sum code	2 bytes	Exclusive OR of Node, Command, and Data
[CR]	Control code (carriage return)	1 byte	[CR] (0x0D)

Command – 0A

The 0A command sets a value in the EEPROM.

The frame format of command 0A follows the diagram and specification table.

Frame format

STX	Node	Command	BCC	[CR]
-----	------	---------	-----	------

Element	Description	Size	Value
STX	Control code (S T art of Te X t)	1 byte	STX (0x02)
Node	Node (station) address of inverter	2 bytes	01 to 32, and FF (broadcast to all nodes)
Command	Transmission command	2 bytes	0A
BCC	Block check sum code	2 bytes	Exclusive OR of Node, Command, and Data
[CR]	Control code (carriage return)	1 byte	[CR] (0x0D)

Command – 0B

The 0B command recalculates the inverter's internal motor constants. Use this function after the base frequency or any Hxxx parameters are changed via the serial link commands.

The frame format of command 0B follows the diagram and specification table.

Frame format

STX	Node	Command	BCC	[CR]
-----	------	---------	-----	------

Element	Description	Size	Value
STX	Control code (S T art of Te X t)	1 byte	STX (0x02)
Node	Node (station) address of inverter	2 bytes	01 to 32
Command	Transmission command	2 bytes	0B
BCC	Block check sum code	2 bytes	Exclusive OR of Node, Command, and Data
[CR]	Control code (carriage return)	1 byte	[CR] (0x0D)

Communications Reference Information

Inverter Affirmative Reply

The standard affirmative reply from the inverter uses the ACK character (acknowledge) in the data field. The frame format of this reply follows the diagram and specification table.

Frame format

STX	Node	ACK	BCC	[CR]
-----	------	-----	-----	------

Element	Description	Size	Value
STX	Control code (STart of TeXt)	1 byte	STX (0x02)
Node	Node (station) address of inverter	2 bytes	01 to 32
ACK	Control code (ACKnowledge)	1 byte	ACK (0x06)
BCC	Block check sum code	2 bytes	Exclusive OR of Node and ACK
[CR]	Control code (carriage return)	1 byte	[CR] (0x0D)

Inverter Negative Reply

The standard negative reply from the inverter uses the NAK character (negative acknowledge) in the data field. The frame format of this reply follows the diagram and specification table.

Frame format

STX	Node	NAK	Error code	BCC	[CR]
-----	------	-----	------------	-----	------

Element	Description	Size	Value
STX	Control code (STart of TeXt)	1 byte	STX (0x02)
Node	Node (station) address of inverter	2 bytes	01 to 32
NAK	Control code (Negative ACKnowledge)	1 byte	NAK (0x15)
Error code	Code representing error type	2 bytes	(See next table below)
BCC	Block check sum code	2 bytes	Exclusive OR of Node, Data, and NAK
[CR]	Control code (carriage return)	1 byte	[CR] (0x0D)

The error codes for a NAK (negative acknowledge) are:

Error Code	Error Description	Error Code	Error Description
01H	Parity error	07H	Receive buffer overrun error
02H	Check sum error	08H	Receive time-out error
03H	Framing error	11H	Abnormal command code error
04H	Overrun error	13H	Execution disabled
05H	Protocol error	16H	Abnormal parameter code/value error
06H	ASCII code error	—	—

If a host computer broadcasts a command to all inverter stations, no response will be returned to the host.

Block Check Code (BCC)

This section shows how the inverter protocol computes defines a BCC—block check code. The BCC is calculated for each frame transmitted and can be used to verify the integrity of data transmission. The example below shows command 01 setting the inverter frequency to 5Hz.

Frame format

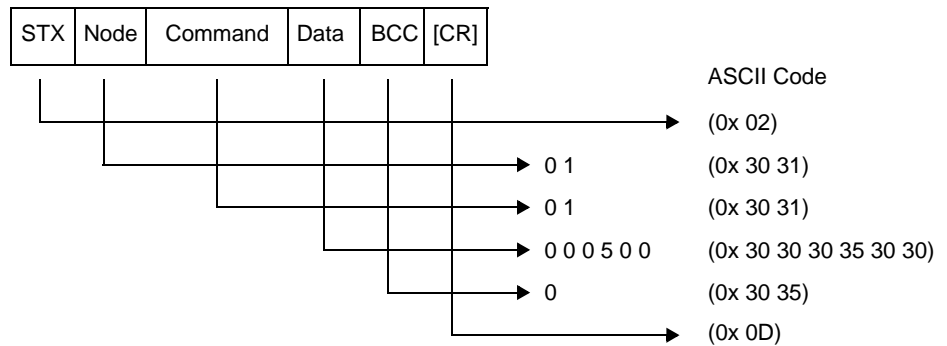

The block check code is computed by using the ASCII codes (shown above) and applying eXclusive OR (XOR) operations. Beginning with the first pair of bytes, the result of their XOR is then used in an XOR operation with the third byte, and so on. For this example, the BCC calculation is shown below.

Data bytes:

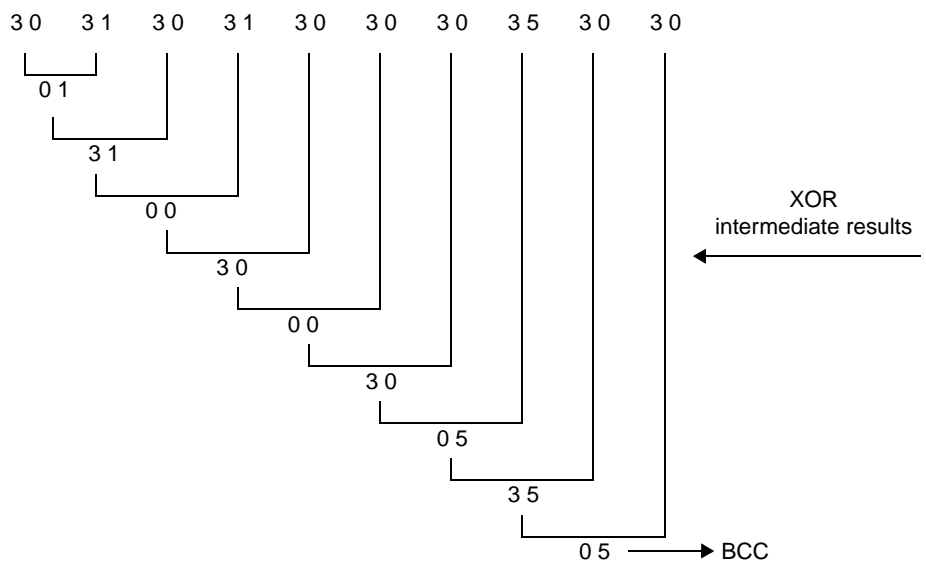

ASCII Code Table The table below shows only the ASCII codes used for function codes and parameter data.

Character	ASCII Code	Character	ASCII Code	Character	ASCII Code
STX	02	4	34	C	43
ACK	06	5	35	D	44
CR	0D	6	36	E	45
NAK	15	7	37	F	46
0	30	8	38	H	48
1	31	9	39	P	50
2	32	A	41	b	62
3	33	B	42	—	—

Communication Test Mode

The communication test mode verifies that the inverter can properly send and receive data via the RS485 serial port. Follow the steps below to perform the communication test.

1. Remove the serial cable (if present) connected to the TM2 connector block of the control terminals, as shown below.



NOTE: It is not necessary to connect a loopback jumper. The RS485 port uses a transceiver for communications, which already allows simultaneous transmitting and receiving.

2. Use the front panel keypad to navigate to parameter C071, Communication Speed Selection. Change parameter C071=02 and press Store. Value 02 is the Loopback Test option. Now the inverter is ready to conduct the loopback test.
3. Turn the inverter power OFF and then ON again to initiate the communication test. Observe the keypad display and compare to the results shown below.



4. Press the Stop/Rest button on the keypad to return the inverter keypad/ display to normal operation.
5. Change C071 to its original setting (default is C071=04). Otherwise, while C071=02, the inverter will perform the communications loopback test at each powerup.

ModBus Mode Communications

Transmission Procedure

The network master sends a frame to initiate communications with a slave, as shown in the figure below.

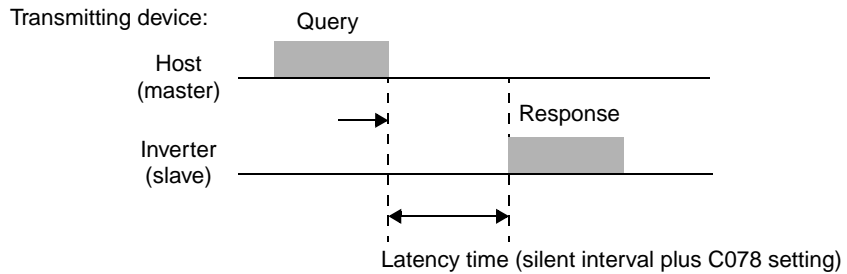

- Query - A frame sent from the external control equipment to the inverter
- Response - A frame returned from the inverter to the external control equipment
- Wait time (C077) - If the inverter cannot complete the reception of a query from the host (master) within the communication timeout period, the inverter responds to the query and waits to receive the query from the beginning. Subsequently, the inverter returns no response to the master system.

After reception timeout occurs, the inverter operates according to function C076, Action upon communication error selection (see table below). Monitoring of reception timeout begins when the first communication is performed upon inverter powerup or a reset. Reception timeout is monitored only when the inverter communicates with the master system.

Function Code	Name/Description	OPE	Range and Settings
C076	Action upon communication error selection	00	Trip (E41)
		01	Trip (E41) after deceleration and stop
		02	No action (ignore errors)
		03	Free-run stop
		04	Decelerate and stop
C077	Communication timeout before trip		0.00 to 99.99 (seconds)
	Limit timer for reception timeout		
C078	Communication wait time		0.0 to 1000 (milliseconds)
	Time to wait until the inverter starts sending a response after reception of a query (excluding the silent interval)		

The inverter always sends a response frame after receiving a query frame. The inverter does not initiate any communication with the host (master).

Message Configuration: Query

Each frame is formatted as follows:

Frame Format
Header (silent interval)
Slave address
Function code
Data
Error check code
Trailer (silent interval)

Slave address:

- This is a number from 1 to 32 assigned to each inverter (slave). (Only the inverter having the address given as a slave address in the query can receive the query.)
- When slave address “0” is specified, the query can be addressed to all inverter simultaneously (broadcasting).
- In broadcasting, the host (master) cannot read inverter data nor perform a loopback test.

Data:

- The data contains a function command.
- The data format used in the SJ7002 corresponds to the ModBus data format below.

Name of Data	Description
Coil	Binary data that can be referenced and changed (1 bit long)
Holding Register	16-bit data that can be referenced and changed

Function Code:

Specify a function you want to make the inverter execute. Function codes available to the SJ7002 are listed below.

Function Code	Function	Maximum data size (bytes available per message)	Maximum number of data elements per message
01h	Read Coil Status	4	32 coils (in bits)
03h	Read Holding Register	8	4 registers (in bytes)
05h	Write in Coil	2	1 coil (in bits)
06h	Write in Holding Register	2	1 register (in bytes)
08h	Loopback Test	—	—
0Fh	Write in Coils	4	32 coils (in bits)
10h	Write in Registers	4	4 registers (in bytes)

Error check:

Modbus-RTU uses CRC (Cyclic Redundancy Check) for error checking.

- The CRC code is 16-bit data that is generated for 8-bit blocks of arbitrary length.
- The CRC code is generated by a generator polynomial CRC-16 ($X^{16} + X^{15} + X^2 + 1$).

Message Configuration: Response

Header and trailer (silent interval):

Latency is the time between the reception of a query from the master and transmission of a response from the inverter.

- The header and trailer set the total time the inverter should wait before sending a response after having received a query from the master system.
- Be sure to specify the time corresponding to the transmission of 3.5 characters (24 bits) as the waiting time. If a shorter waiting time (corresponding to the transmission of fewer than 3.5 characters) is specified, the inverter will not respond.
- The actual waiting time is the sum of the silent interval (corresponding to the transmission of 3.5 characters) and the communication wait time (C078).

Time required for communication:

- After the inverter receives a query, the inverter waits for the sum of the silent interval (corresponding to the transmission of 3.5 characters) and the communication wait time (C078) before sending a response.
- After receiving a response from the inverter, the master system must wait for the silent interval (corresponding to the transmission of 3.5 characters) or longer before sending the next query to the inverter.

Normal response:

- If the query specifies the function code (08h) for the loopback test, the inverter returns a response that has the same contents as the query.
- If the query specifies a function code (05h, 06h, 0Fh, or 10h) for writing data to registers or coils, the inverter returns the query without a change as a response.
- If the query specifies a function code (01h or 03h) for reading a register or coil, the inverter returns a response that contains the slave address and function code specified in the query and the data read from the register or coil.

Response when an error occurs:

- When finding any error in a query (except for a transmission error), the inverter returns an exception response without executing anything,
- You can check the error by the function code in the response. The function code of the exception response is the sum of the function code of the query and 80h.
- The content of the error is known from the exception code.

Field Configuration
Slave address
Function code
Exception code
CRC-16

Exception Code	Description
0 1 h	The specified function is not supported.
0 2 h	The specified address is not found.
0 3 h	The format of the specified data is not acceptable.
2 1 h	The data to be written in a holding register is outside the inverter.

Exception Code	Description
22h	<p>The specified functions are not available to the inverter.</p> <ul style="list-style-type: none"> • Function to change the content of a register that cannot be changed while the inverter is in service • Function to submit an ENTER command during running (UV) • Function to write in a register during tripping (UV) • Function to write in a read-only register (or coil)

No response occurs:

In the cases below, the inverter ignores a query and returns no response.

- When receiving a broadcasting query
- When detecting a transmission error in reception of a query
- When the slave address set in the query is not equal to the slave address of the inverter
- When a time interval between data elements constituting a message is shorter than 3.5 characters
- When the data length of the query is invalid



NOTE: Provide a timer in the master and make the master retransmit the same query when no response is made within a preset time period after the preceding query was sent.

Explanation of Function Codes

Read Coil Status [01h]:

This function reads the status (ON/OFF) of selected coils. An example follows below.

- Read intelligent input terminals [1] to [6] of an inverter having a slave address “8.”
- This example assumes the intelligent input terminals have terminal states listed below (coils 13 and 14 are OFF).

Item	Data					
Intelligent input terminal	[1]	[2]	[3]	[4]	[5]	[6]
Coil number	7	8	9	10	11	12
Terminal status	ON	ON	ON	OFF	ON	OFF

Query:

No.	Field Name	Example (hex)
1	Slave address *1	08
2	Function code	01
3	Coil start number (high order)	00
4	Coil start number (low order)	06
5	Number of coils (high order) *2	00
6	Number of coils (low order) *2	06
7	CRC-16 (high order)	5C
8	CRC-16 (low order)	90

Note 1: Broadcasting is disabled.

Note 2: The starting coil number is one less than the number of the coil to be read first.

Note 3: When 0 or more than 32 is specified as a number of coils, error code “03h” is returned.

- The data set in the response shows terminal states of coils 7 to 14.
- Data “17h = 00010111b” indicates the following assuming coil 7 is the LSB.

Item	Data							
Coil number	14	13	12	11	10	9	8	7
Coil status	OFF	OFF	OFF	ON	OFF	ON	ON	ON

- When a read coil is outside the defined coils, the final coil data to be transmitted contains “0” as the status of the coil outside the range.
- When the Read Coil Status command cannot be executed normally, see the exception response.

Response:

No.	Field Name	Example (hex)
1	Slave address	08
2	Function code	01
3	Data size (in bytes)	01
4	Coil data *4	17
5	CRC-16 (high order)	12
6	CRC-16 (low order)	1A

Note 4: Data is transferred by the specified number of data bytes (data size).

Read Holding Register [03h]:

This function reads the contents of the specified number of consecutive holding registers (of specified register addresses). An example follows below.

- Reading previous three trip factors from an inverter having a slave address “5”
- This example assumes the previous three trip factors are as follows:

SJ7002 Command	D081 (N)	D082 (N-1)
Register number	0012h	0013h
Trib factor (upper digit)	Over-voltage (E07)	Decelerating (02)

Query:

No.	Field Name	Example (hex)
1	Slave address *1	05
2	Function code	03
3	Register start number (high order)	00
4	Register start number (low order)	11
5	Number of registers (high order) *2	00
6	Number of registers (low order) *2	02
7	CRC-16 (high order)	95
8	CRC-16 (low order)	8A

- Note 1:** Broadcasting is disabled.
Note 2: The starting coil number is one less than the number of the coil to be read first.

Response:

No.	Field Name	Example (hex)
1	Slave address	05
2	Function code	03
3	Data size (in bytes) *3	04
4	Register start number (high order)	00
5	Register start number (low order)	07
6	Register start number +1 (high order)	00
7	Register start number +1 (low order)	02
8	CRC-16 (high order)	36
9	CRC-16 (low order)	37

- Note 3:** Data is transferred by the specified number of data bytes (data size). In this case, 4 bytes are used to return the content of two holding registers.

The data set in the response is as follows:

Response Buffer	4	5	6	7
Starting register number	+0 (high order)	+0 (low order)	+1 (high order)	+1 (low order)
Register status	00h	07h	00h	02h
Trip data	Over-voltage trip		Decelerating	

When the Read Holding Register command cannot be executed normally, refer to the exception response.

Write in Coil [05h]:

This function writes data in a single coil. Coil status changes are as follows:

Data	Coil Status	
	OFF to ON	ON to OFF
Change data (high order)	FFh	00h
Change data (low order)	00h	00h

An example follows (note that to command the inverter, set A002=03):

- Sending a RUN command to an inverter having slave address “10”
- This example writes in coil number “1.”

Query:

No.	Field Name	Example (hex)
1	Slave address *1	0A
2	Function code	05
3	Coil start number (high order)	00
4	Coil start number (low order) *2	00
5	Change data (high order)	FF
6	Change data (low order)	00
7	CRC-16 (high order)	8D
8	CRC-16 (low order)	41

Response:

No.	Field Name	Example (hex)
1	Slave address	0A
2	Function code	05
4	Coil start number (high order)	00
5	Coil start number (low order)	00
6	Change data (high order)	FF
7	Change data (low order)	00
8	CRC-16 (high order)	8D
9	CRC-16 (low order)	41

Note 1: Broadcasting is disabled.

Note 2: The starting coil number is one less than the number of the coil to be read first.

When the Write in Coil command cannot be executed normally, refer to the exception response.

Write in Holding Register [06h]:

This function writes data in a specified holding register. An example follows below.

- Write “50Hz” as the first Multi-speed 0 (A020) in an inverter having slave address “5.”
- This example uses change data “50 (0032h)” to set “50Hz” as the data resolution of the register “1203h” holding the base frequency setting (A003) is 1 Hz.

SJ7002 Command	D081 (N)	D082 (N-1)
Register number	0012h	0013h
Trib factor (upper digit)	Over-voltage (E07)	Decelerating (02)

Query:

No.	Field Name	Example (hex)
1	Slave address *1	05
2	Function code	06
3	Register start number (high order) *2	12
4	Register start number (low order) *2	02
5	Change data (high order)	00
6	Change data (low order)	32
7	CRC-16 (high order)	AD
8	CRC-16 (low order)	23

Response:

No.	Field Name	Example (hex)
1	Slave address	05
2	Function code	06
3	Register start number (high order)	12
4	Register start number (low order)	02
5	Change data (high order)	00
6	Change data (low order)	32
7	CRC-16 (high order)	AD
8	CRC-16 (low order)	23

Note 1: Broadcasting is disabled.

Note 2: The starting coil number is one less than the number of the coil to be read first.

When the Write Holding Register command cannot be executed normally, refer to the exception response.

Loopback Test [08h]:

This function checks a master-slave transmission using any test data. An example follows:

- Send test data to an inverter having slave address “1” and receiving the test data from the inverter (as a loopback test).

Query:

No.	Field Name	Example (hex)
1	Slave address *1	01
2	Function code	08
3	Test subcode (high order)	00
4	Test subcode (low order)	00
5	Data (high order)	Any
6	Data (low order)	Any
7	CRC-16 (high order)	CRC
8	CRC-16 (low order)	CRC

Response:

No.	Field Name	Example (hex)
1	Slave address	01
2	Function code	08
3	Test subcode (high order)	00
4	Test subcode (low order)	00
5	Data (high order)	Any
6	Data (low order)	Any
7	CRC-16 (high order)	AD
8	CRC-16 (low order)	23

Note 1: Broadcasting is disabled.

The test subcode is for echo (00h,00h) only and not available to the other commands.

Write in Coils [0Fh]:

This function writes data in consecutive coils. An example follows:

- Change the state of intelligent input terminal [1] to [6] of an inverter having a slave address “5.”
- This example assumes the intelligent input terminals have terminal states listed below.

Item	Data					
	[1]	[2]	[3]	[4]	[5]	[6]
Intelligent input terminal	[1]	[2]	[3]	[4]	[5]	[6]
Coil number	7	8	9	10	11	12
Terminal status	ON	ON	ON	OFF	ON	OFF

Query:

No.	Field Name	Example (hex)
1	Slave address *1	05
2	Function code	0F
3	Coil start number (high order)	00
4	Coil start number (low order)	06
5	Number of coils (high order) *2	00
6	Number of coils (low order) *2	06
7	Byte number *3	02
8	Change data (high order) *3	17
9	Change data (low order)*3	00
10	CRC-16 (high order)	DB
11	CRC-16 (low order)	3E

Note 1: Broadcasting is disabled.

Note 2: The starting coil number is one less than the number of the coil to be read first.

Note 3: The change data is a set of high-order data and low-order data. So when the size (in bytes) of data to be changed is an odd number, add “1” to the data size (in bytes) to make it an even number

Response:

No.	Field Name	Example (hex)
1	Slave address	05
2	Function code	0F
3	Coil start number (high order)	00
4	Coil start number (low order)	06
5	Number of coils (high order) *2	00
6	Number of coils (low order) *2	06
7	CRC-16 (high order)	34
8	CRC-16 (low order)	4C

Note 4: Data is transferred by the specified number of data bytes (data size).

When the Write in Coils command cannot be executed normally, see the exception response.

Write in Holding Registers [10h]:

This function writes data in consecutive holding registers. An example follows:

- Write “3000 seconds” as the first acceleration time 1 (F002) in an inverter having a slave address “1.”
- This example uses change data “300000 (493E0h)” to set “3000 seconds” as the data resolution of the registers “1103h” and “1104h” holding the first acceleration time 1 (F002) is 0.01 second.

Query:

No.	Field Name	Example (hex)
1	Slave address *1	01
2	Function code	10
3	Start address (high order) *2	11
4	Start address (low order) *2	02
5	Number of holding registers (high order)	00
6	Number of holding registers (low order)	02
7	Byte number *3	04
8	Change data 1 (high order)	00
9	Change data 1 (low order)	04
10	Change data 2 (high order)	93
11	Change data 2 (low order)	E0
12	CRC-16 (high order)	9E
13	CRC-16 (low order)	9F

Response:

No.	Field Name	Example (hex)
1	Slave address *1	01
2	Function code	10
3	Register start number (high order)	11
4	Register start number (low order)	02
5	Number of holding registers (high order)	00
6	Number of holding registers (low order)	02
7	CRC-16 (high order)	E5
8	CRC-16 (low order)	34

Note 1: Broadcasting is disabled.

Note 2: The starting coil number is one less than the number of the coil to be read first.

When the Write Holding Register command cannot be executed normally, refer to the exception response.

Exception Response:

When sending a query (excluding a broadcasting query) to an inverter, the master always requests a response from the inverter. Usually, the inverter returns a response according to the query. However, when finding an error in the query, the inverter returns an exception response. The exception response consists of the fields shown below.

Field Configuration
Slave address
Function code
Exception code
CRC-16

The content of each field is explained below. The function code of the exception response is the sum of the function code of the query and 80h. The exception code indicates the factor of the exception response.

Function Code	
Query	Exception Response
0 1 h	8 1 h
0 3 h	8 3 h
0 5 h	8 5 h
0 6 h	8 6 h
0 F h	8 F h
1 0 h	9 0 h

Exception Code	Description
0 1 h	The specified function is not supported.
0 2 h	The specified address is not found.
0 3 h	The format of the specified data is not acceptable.
2 1 h	The data to be written in a holding register is outside the inverter.
2 2 h	The specified functions are not available to the inverter. <ul style="list-style-type: none"> • Function to change the content of a register that cannot be changed while the inverter is in service • Function to submit an ENTER command during running (UV) • Function to write in a register during tripping (UV) • Function to write in a read-only register (or coil)

Store New Register Data (ENTER Command)

Neither the command (06h) to write data to a register nor the command (10h) to write data to multiple registers can store the updates they made in the internal memory of the inverter. Turning the inverter power off without storing the updates deletes them and restores the original register settings. If you intend to store register updates in the internal memory of the inverter, issue the Enter command as described below.

If you have updated a control constant, you must recalculate the motor constants. In such cases, use register "0900h" for recalculation as described below.

Submitting an ENTER Command:

- Write any data in all memory (of a holding register at 0900h) by the Write in Holding Register command [06h].

Write Data	Description
0000	Recalculate the motor constants
0001	Store the register data
Other	Recalculate the motor constants and store the register data



NOTE: The ENTER command takes much time to run. You can check its progress by monitoring the Data Writing signal (of a coil at 001Ah).



NOTE: The service life of the storage element of the inverter is limited (to about 100,000 write operations). Frequent use of the ENTER command may shorten its service life.

ModBus Data Listing

ModBus Coil List The following tables list the primary coils for the inverter interface to the network. The table legend is given below.

- **Coil Number** - The network register address offset for the coil, in hex and decimal. Actual network address is 30001 + offset. The coil data is a single bit (binary) value.
- **Name** - The functional name of the coil
- **R/W** - The read-only (R) or read-write (R/W) access permitted to the inverter data
- **Description** - The meaning of each of the states of the coils

List of Coil Numbers				
Coil number		Name	R/W	Description
hex	dec.			
0000h	00000	(Reserved)	—	—
0001h	00001	Operation command	R/W	0 ... Stop 1 ... Run (enabled when A003=03)
0002h	00002	Rotation direction command	R/W	0 ... REV 1 ... FW (enabled when A003=03)
0003h	00003	External trip (EXT)	R/W	0 ... No trip event 1 ... Trip occurred
0004h	00004	Trip reset (RS)	R/W	0 ... No reset condition 1 ... Reset
0005h	00005	(Reserved)	—	—
0006h	00006	(Reserved)	—	—
0007h	00007	Intelligent input terminal [1]	R/W	0 ... OFF *1 1 ... ON
0008h	00008	Intelligent input terminal [2]	R/W	
0009h	00009	Intelligent input terminal [3]	R/W	
000Ah	00010	Intelligent input terminal [4]	R/W	
000Bh	00011	Intelligent input terminal [5]	R/W	
000Ch	00012	Intelligent input terminal [6]	R/W	
000Dh	00013	Intelligent input terminal [7]	R/W	
000Eh	00014	Intelligent input terminal [8]	R/W	
000Fh	00015	Run/Stop status	R	0 ... Stop (corresponds to D003 monitor) 1 ... Run
0010h	00016	FW/REV status	R	0 ... FW 1 ... RV
0011h	00017	Inverter ready	R	0 ... Not ready 1 ... Ready
0012h	00018	(Reserved)	R	—
0013h	00019	RUN (running)	R	0 ... OFF 1 ... ON
0014h	00020	FA2 - Frequency Arrival (constant-speed reached)	R	
0015h	00021	FA2 - Frequency Arrival (above set frequency)	R	
0016h	00022	OL - Overload signal	R	
0017h	00023	OD - PID deviation signal	R	

List of Coil Numbers				
Coil number		Name	R/W	Description
hex	dec.			
0018h	00024	AL - Alarm signal	R	0... OFF 1... ON
0019h	00025	FA3 - Frequency arrival signal (set frequency or above)	R	
001Ah	00026	OTQ - Over-torque	R	
001Bh	00027	IP - Instantaneous power failure	R	
001Ch	00028	UV - Undervoltage	R	
001Dh	00029	TRQ - Torque limit	R	
001Eh	00030	RNT - Operation time over	R	
001Fh	00031	ONT - Plug-in time over	R	
0020h	00032	THM - Thermal alarm signal	R	
0021h	00033	(Reserved)	—	
0022h	00034	(Reserved)	—	
0023h	00035	(Reserved)	—	
0024h	00036	(Reserved)	—	
0025h	00037	(Reserved)	—	
0026h	00038	BRK - Brake release	R	0... OFF 1... ON
0027h	00039	BER - Brake error	R	
0028h	00040	ZS - 0 Hz detection signal	R	
0029h	00041	DSE - Speed deviation maximum	R	
002Ah	00042	POK - Positioning completed	R	
002Bh	00043	FA4 - Set frequency overreached 2	R	
002Ch	00044	FA5 - Set frequency reached 2	R	
002Dh	00045	OL2 - Overload notice advance signal 2	R	
002Eh	00046	Odc - Analog O disconnection detection	R	
002Fh	00047	OIDc - Analog OI disconnection detection	R	
0030h	00048	O2Dc - Analog O2 disconnection detection	R	
0031h	00049	(Reserved)	—	
0032h	00050	FBV - PID feedback comparison	R	0... OFF 1... ON
0033h	00051	NDc - Communication bus disconnection	R	
0034h	00052	LOG1 - Logical operation result 1	R	

Note 1: ON usually when either the control circuit terminal board or a coil is ON. Among intelligent input terminals, the control circuit terminal board is a high-priority terminal. If the master cannot reset the coil ON status due to a transmission line break, turn ON and OFF the control circuit terminal board to make the coil OFF status.

Note 2: The content of a transmission error is held until the error is reset. (The error can be reset while the inverter is running.)

ModBus Holding Registers

The following tables list the holding registers for the inverter interface to the network. The table legend is given below.

- **Function Code** - The inverter’s reference code for the parameter or function (same as inverter keypad display). Long-word values (32) bits are listed in two rows; “H” and “L” indicate the *high* and *low* order words.
- **Name** - The standard functional name of the parameter or function for the inverter
- **R/W** - The read-only or read-write access permitted to the data in the inverter
- **Description** - How the parameter or setting works (same as Chapter 3 description)
- **Register** - The network register address offset for the value, in hex and decimal. Actual network address is 40001 + offset. Some values have a high-byte and low-byte address.
- **Range** - The numerical range for the network value that is sent and/or received



TIP: The network values are binary integers. Since these values cannot have an embedded decimal point, for many parameters it represents the actual value (in engineering units) multiplied by a factor of 10 or 100. Network communications must use the listed range for network data. The inverter automatically divides received values by the appropriate factor in order to establish the decimal point for internal use. Likewise, the network host computer must apply the same factor when it needs to work in engineering units. However, when sending data to the inverter, the network host computer must scale values to the integer range listed for network communications.

- **Resolution** - This is the quantity represented by the LSB of the network value, in engineering units. When the network data range is greater than the inverter’s internal data range, this 1-bit resolution will be fractional.

Holding Registers, “D” Group Monitor Functions							
Func. Code	Name	R/W	Description	Network Data			
				Register		Range	Res.
				hex	dec.		
—	Inverter status A	R	0 = Initial status; 1 = Waiting for Vdc level; 2 = Stopping; 3 = Running; 4 = Free-run Stop (FRS); 5 = Jogging; 6 = DC Braking; 7 = Freq. is input; 8 = Retrying operation; 9 = Under-voltage (UV)	0003h	00003	0 to 9	—
—	Inverter status B	R	0 = Stopping; 1 = Running; 2 = Tripping	0004h	00004	0, 1, 2	—
—	Inverter status C	R	0 = ---; 1 = Stopping; 2 = Decelerating; 3 = Constant-speed operation; 4 = Accelerating; 5 = Forward rotation; 6 = Reverse rotation; 7 = Forward-to-reverse rotation transition; 9 = Starting forward rotation; 10 = Starting reverse rotation	0005h	00005	0 to 10	—
—	PID feedback	R/W		0006h	00006		
—	(Reserved)	—	—	0007h to 0010h	00007 to 00016	—	—

Holding Registers, "D" Group Monitor Functions								
Func. Code	Name	R/W	Description	Network Data				
				Register		Range	Res.	
				hex	dec.			
D001	H	Output frequency monitor	R	Real-time display of output frequency to motor, from 0.0 to 400.0 Hz	1001h	04097	0 to 40000	0.01 Hz
D001	L		R		1002h	04098		
D002	—	Output current monitor	R	Filtered display of output current to motor (100 mS internal filter time constant)	1003h	04099	0 to 9999	0.01 A
D003	—	Rotation direction monitor	R	0 ...Stop 1 ...Forward 2 ...Reverse	1004h	04100	0, 1, 2	—
D004	H	Process variable (PV), PID feedback monitor	R	Displays the scaled PID process variable (feedback) value (A75 is scale factor)	1005h	04101	0 to 9990	0.1
D004	L		R		1006h	04102		
D005	—	Intelligent input terminal status	R	Displays the state of the intelligent input terminals	1007h	04103	bit 0 = [1] bit 7= [8] terminals	1 bit
D006	—	Intelligent output terminal status	R	Displays the state of the intelligent input terminals	1008h	04101	bit0 = [11] bit 4 = [15] terminals	1 bit
D007	H	Scaled output frequency monitor	R	Displays the output frequency scaled by the constant in B0086. Decimal point indicates range: XX.XX 0.00 to 99.99 XXX.X 100.0 to 999.9 XXXX. 1000 to 9999 XXXX 10000 to 99990	1009h	04105	0 to 39960	0.01
D007	L		R		100Ah	04106		
D008	H	Actual frequency monitor	R	Displays the actual shaft speed of the motor, converted to frequency	100Bh	04107	-40000 to +40000	0.01 Hz
D008	L		R		100Ch	04108		
D009	—	Torque command monitor	R	Displays the level of the torque command when the inverter is set to torque control mode	100Dh	04109	-200 to 200	1 %
D010	—	Torque bias monitor	R	Displays the level of the torque bias, if enabled, when the inverter is in vector control mode with feedback	100Eh	04110	-200 to 200	1 %
—	—	(Reserved)	R	—	100Fh	04111	—	—
D012	—	Torque monitor	R	Estimated output torque value, range is -300.0 to +300.0%	1010h	04112	-200 to 200	1 %
D013	—	Output voltage monitor	R	Voltage of output to motor, range is 0.0 to 600.0V	1012h	04113	0 to 6000	0.1 V
D014	—	Power monitor	R	Input power to inverter, range is 0.0 to 999.9	1013h	04114	0 to 9999	0.1 kW
D015	H	Cumulative power monitor	R	Displays cumulative input power to inverter; B079 selects the multiplier for units. Range is 0.0 to 999.9, 1000 to 9999, or 100 to 999	1014h	04115	0 to 9999999	0.1
D015	L		R		1014h	04116		

Holding Registers, "D" Group Monitor Functions								
Func. Code	Name	R/W	Description	Network Data				
				Register		Range	Res.	
				hex	dec.			
D016	H	Cumulative operation RUN time monitor	R	Displays total time the inverter has been in RUN mode in hours. Range is 0 to 9999 / 1000 to 9999 / 100 to 999 (10,000 to 99,900) hrs.	1015h	04117	0 to 999900	0.1
D016	L		R		1016h	04118		
D017 (high)	H	Cumulative power-on time monitor	R	Displays total time the inverter has had input power (ON) in hours. Range is: 0 to 9999 / 100.0 to 999.9 / 1000 to 9999 / 100 to 999 hrs.	1017h	04119	0 to 999900	1 hour
D017 (low)	L		R		1018h	04120		
D018	—	Heat sink temperature monitor	R	Displays the temperature of the inverter's heat sink	1019h	04121	-200 to 2000	0.1 °C
D019	—	Motor temperature monitor	R	Displays motor internal temperature (requires an NTC thermistor installed in the motor and connected to [TH] and [CM1])	101Ah	04122	-200 to 2000	0.1 °C
—		(Reserved)	—	—	101Bh	04123	—	—
—		(Reserved)	—	—	101Ch	04124	—	—
D022	—	Component life monitor	R	Displays estimated life status of DC bus capacitors and cooling fans	101Dh	04125	bit 0... capacitors bit 1...fans	1 bit
—		(Reserved)	—	—	101Eh to 1025h	04126 to 04133	—	—
D025	H	User monitor 0	R	Displays state of internal EZ Sequence register User Monitor 0	102Eh	04142	-2147483647 to 2147483647	1
D025	L		R		102Fh	04143		
D026	H	User monitor 1	R	Displays state of internal EZ Sequence register User Monitor 2	1030h	04144	-2147483647 to 2147483647	1
D026	L		R		1031h	04145		
D027	H	User monitor 2	R	Displays state of internal EZ Sequence register User Monitor 2	1032h	04146	-2147483647 to 2147483647	1
D027	L		R		1033h	04147		
D028	H	Pulse counter	R/W	Displays accumulated pulse count of [PCNT] intelligent input terminal (option code 74)	1034h	04148	0 to 2147483647	1
D028	L		R/W		1035h	04149		
D029	H	Position setting monitor	R	Displays absolute position command for motor shaft in absolute position control mode	1036h	04150	-2147483647 to 2147483647	1
D029	L		R		1037h	04151		
D030	H	Position feedback monitor	R	Displays absolute position of motor shaft when in absolute position control mode	1038h	04152	-2147483647 to 2147483647	1
D030	L		R		1039h	04153		
D080	—	Trip counter	R	Number of trip events	0011h	00017	0 to 65535	1 trip event

Holding Registers, "D" Group Monitor Functions							
Func. Code	Name	R/W	Description	Network Data			
				Register		Range	Res.
				hex	dec.		
D081	Trip monitor 1	R	Factor code	0012h	00018	(see codes in next table)	—
		R	Inverter status	0013h	00019		—
		R	Frequency (high)	0014h	00020	0 to 40000	0.01 Hz
		R	Frequency (low)	0015h	00021		
		R	Current	0016h	00022	—	0.1 A
		R	Voltage	0017h	00023	—	1 V
		R	Run time (high)	0018h	00024	—	1 hour
		R	Run time (low)	0019h	00025		
		R	ON time (high)	001Ah	00026	—	1 hour
		R	ON time (low)	001Bh	00027		
D082	Trip monitor 2	R	Factor code	001Ch	00028	(see codes in next table)	—
		R	Inverter status	001Dh	00029		—
		R	Frequency (high)	001Eh	00030	0 to 40000	0.01 Hz
		R	Frequency (low)	001Fh	00031		
		R	Current	0020h	00032	—	0.1 A
		R	Voltage	0021h	00033	—	1 V
		R	Run time (high)	0022h	00034	—	1 hour
		R	Run time (low)	0023h	00035		
		R	ON time (high)	0024h	00036	—	1 hour
		R	ON time (low)	0025h	00037		
D083	Trip monitor 3	R	Factor code	0026h	00038	(see codes in next table)	—
		R	Inverter status	0027h	00039		—
		R	Frequency (high)	0028h	00040	0 to 40000	0.01 Hz
		R	Frequency (low)	0029h	00041		
		R	Current	002Ah	00042	—	0.1 A
		R	Voltage	002Bh	00043	—	1 V
		R	Run time (high)	002Ch	00044	—	1 hour
		R	Run time (low)	002Dh	00045		
		R	ON time (high)	002Eh	00046	—	1 hour
		R	ON time (low)	002Fh	00047		

Holding Registers, "D" Group Monitor Functions								
Func. Code	Name	R/W	Description	Network Data				
				Register		Range	Res.	
				hex	dec.			
D084	Trip monitor 4	R	Factor code	0030h	00048	(see codes in next table)	—	
		R	Inverter status	0031h	00049		—	
		R	Frequency (high)	0032h	00050	0 to 40000	0.01 Hz	
		R	Frequency (low)	0033h	00051			
		R	Current	0034h	00052	—	0.1 A	
		R	Voltage	0035h	00053	—	1 V	
		R	Run time (high)	0036h	00054	—	1 hour	
		R	Run time (low)	0037h	00055			
		R	ON time (high)	0038h	00056	—	1 hour	
		R	ON time (low)	0039h	00057			
D085	Trip monitor 5	R	Factor code	003Ah	00058	(see codes in next table)	—	
		R	Inverter status	003Bh	00059		—	
		R	Frequency (high)	003Ch	00060	0 to 40000	0.01 Hz	
		R	Frequency (low)	003Dh	00061			
		R	Current	003Eh	00062	—	0.1 A	
		R	Voltage	003Fh	00063	—	1 V	
		R	Run time (high)	0040h	00064	—	1 hour	
		R	Run time (low)	0041h	00065			
		R	ON time (high)	0042h	00066	—	1 hour	
		R	ON time (low)	0043h	00067			
D086	Trip monitor 6	R	Factor code	0044h	00068	(see codes in next table)	—	
		R	Inverter status	0045h	00069		—	
		R	Frequency (high)	0046h	00070	0 to 40000	0.01 Hz	
		R	Frequency (low)	0047h	00071			
		R	Current	0048h	00072	—	0.1 A	
		R	Voltage	0049h	00073	—	1 V	
		R	Run time (high)	004Ah	00074	—	1 hour	
		R	Run time (low)	004Bh	00075			
		R	ON time (high)	004Ch	00076	—	1 hour	
		R	ON time (low)	004Dh	00077			
D090	Programming error monitor	R	Displays programming error code	004Eh	00078	Warning code	—	
—	(Reserved)	—	—	004Fh to 08FFh	00079 to 02303	—	—	

Holding Registers, "D" Group Monitor Functions							
Func. Code	Name	R/W	Description	Network Data			
				Register		Range	Res.
				hex	dec.		
—	Write to EEPROM	W	00 .Motor constant calculation 01 . Set data storage in EEPROM Other... Motor constant recal- culation and set data storage in EEPROM	0900h	02304	0000, 0001, other	—
—	(Reserved)	—	—	0901h to 1000h	02305 to 4096	—	—
D102	DC voltage monitoring		Displays the DC Bus voltage	1026h	04134	0 to 9999	0.1 V
D103	BRD load factor monitor- ing		Displays the running average Dynamic Braking usage ratio (%ED)	1027h	04135	0 to 1000	0.1 %
D104	Electronic thermal overload monitoring		Displays the motor electronic thermal overload estimated temperature ratio. If the value reaches 100%, the inverter will trip (E05)	1028h	04136	0 to 1000	0.1 %
—	(Reserved)	—	—	1029h to 102Dh	04137 to 04141	—	—

Note 1: Assume that the inverter current rating is 1000 (for D002).

Note 2: When the value is 10000 (100.0 seconds), a value in the second decimal place is ignored.

Trip Factor Code, HIGH order		Trip Factor Code, LOW order (inverter status)	
Code	Name	Code	Name
0	No trip	0	Reset
1	Over current event while at constant speed	1	Stop
2	Over current event during deceleration	2	Deceleration
3	Over current event during acceleration	3	Constant speed
4	Over current event during other conditions	4	Acceleration
5	Overload protection	5	Run Command active with 0 Hz speed reference
6	Braking resistor overload	6	Starting
7	Over voltage protection	7	DC braking
8	EEPROM error	8	Overload restriction
9	Under-voltage error	9	SON or FOC operation in progress
10	CT (current transformer) error		
11	CPU error		
12	External trip		
13	USP		
14	Ground fault		
15	Input over-voltage		
16	Instantaneous power failure		
20	Inverter thermal trip with low fan speed		
21	Inverter thermal trip		
23	Gate array error		
24	Phase failure detection		
25	Main circuit error		
30	IGBT error		
35	Thermistor		
36	Brake error		
37	Emergency stop		
38	Low-speed overload protection		
43	Easy sequence error (invalid instruction)		
44	Easy sequence error (invalid nesting count)		
45	Easy sequence execution error 1		
50 to 59	Easy sequence user trip 0 to 9		
60 to 69	Expansion card #1 error 0 to 9		
70 to 79	Expansion card #2 error 0 to 9		

Holding Registers, "F" Group Main Profile Parameters								
Func. Code	Name	R/W	Description	Network Data				
				Register		Range	Res.	
				hex	dec.			
F001	H		Standard default target frequency that determines constant motor speed (when A001 = 03)	0001h	00001	0 to 40000	0.01 Hz	
F001	L			0002h	00002			
F002	H		Standard default acceleration	1103h	04355	1 to 360000	0.01 sec.	
F002	L			1104h	04356			
F202	H		Standard default acceleration, 2nd motor	2103h	08451	1 to 360000	0.01 sec.	
F202	L			2104h	08452			
F302	H		Standard default acceleration, 3rd motor	3103h	12547	1 to 360000	0.01 sec.	
F302	L			3104h	12548			
F003	H		Standard default deceleration	1105h	04357	1 to 360000	0.01 sec.	
F003	L			1106h	04358			
F203	H		Standard default deceleration, 2nd motor	2105h	08453	1 to 360000	0.01 sec.	
F203	L			2106h	08454			
—	—	(Reserved)	—	2107h to 2202h	08455 to 08706	—	—	
F303	H		Standard default deceleration, 3rd motor	3105h	12549	1 to 360000	0.01 sec.	
F303	L			3106h	12550			
—	—	(Reserved)	—	3107h to 3202h	12551 to 12802	—	—	
F004	—	Keypad Run key routing	R/W	1107h	04359			
—	—	(Reserved)	—	1108h to 1200h	04360 to 04608	—	—	

Holding Registers, "A" Group Standard Functions								
Func. Code	Name	R/W	Description	Network Data				
				Register		Range	Res.	
				hex	dec.			
A001	—	Frequency source setting	R/W	00 . Keypad potentiometer 01 . Control terminal 02 . Function F001 setting 03 . RS485 serial command 04 . Expansion board #1 05 . Expansion board #2 06 . Pulse train input 07 . Easy sequence 10 . Calculate function input	1201h	04609	00 to 07, 10	—
A002	—	Run command source setting	R/W	01 . Input [FW] or [RV] 02 . Run key on keypad 03 . RS485 serial command 04 . Start/stop, Exp. card #1 05 . Start/stop, exp. card #2	1202h	04610	01 to 05	—
A003	—	Base frequency setting	R/W	30 . to max. frequency (Hz)	1203h	04611	30 to A004 val.	1 Hz
A203	—	Base frequency setting, 2nd motor	R/W	30 . to max. frequency (Hz)	2203h	08707	30 to A004 val.	1 Hz
A303	—	Base frequency setting, 3rd motor	R/W	30 . to max. frequency (Hz)	3203h	12803	30 to A004 val.	1 Hz
A004	—	Maximum frequency setting	R/W	30 . to 400. (Hz)	1204h	04612	30 to 400	1 Hz
A204	—	Maximum frequency setting, 2nd motor	R/W	30 . to 400. (Hz)	2204h	08708	30 to 400	1 Hz
—	—	(Reserved)	—	—	2205h to 2215h	08709 to 08725	—	—
A304	—	Maximum frequency setting, 3rd motor	R/W	30 . to 400. (Hz)	3204h	12804	30 to 400	1 Hz
—	—	(Reserved)	—	—	3205h to 3215h	12805 to 12821	—	—
A005	—	[AT] selection	R/W	00 . Select between [O] and [OI] at [AT] 01 . Select between [O] and [O2] at [AT] 02 . Select between [O] and keypad pot. 03 . Select between [OI] and keypad pot. 04 . Select between [O2] and keypad pot.	1205h	04613	00 to 04	—
A006	—	[O2] selection	R/W	00 . No summing, [O2] and [OI] 01 . Sum of [O2] and [OI], neg. sum (reverse speed reference) inhibited 02 . Sum of [O2] and [OI], neg. sum (reverse speed reference) allowed 03 . Disable [O2] input	1206h	046	00 to 03	—

Holding Registers, "A" Group Standard Functions								
Func. Code		Name	R/W	Description	Network Data			
					Register		Range	Res.
					hex	dec.		
—		(Reserved)	—	—	1207h to 120Ah	04614 to 04618	—	—
A011	H	[O]–[L] input active range start frequency	R/W	The output frequency corresponding to the voltage input range starting point	120Bh	04619	0 to 40000	0.01 Hz
A011	L				120Ch	04620		
A012	H	[O]–[L] input active range end frequency	R/W	The output frequency corresponding to the voltage input range ending point	120Dh	04621	0 to 40000	0.01 Hz
A012	L				120Eh	04622		
A013	—	[O]–[L] input active range start voltage	R/W	The starting point for the voltage input range	120Fh	04623	0 to A014 value	1 %
A014	—	[O]–[L] input active range end voltage	R/W	The ending point for the voltage input range	1210h	04624	A013 value to 100	1 %
A015	—	[O]–[L] input start frequency enable	R/W	00..Use A011 start value 01..Use 0 Hz	1211h	04625	0, 1	—
A016	—	External frequency filter time const.	R/W	n = 1 to 30 (where n = number of samples for average); 31 = 500ms filter	1212h	04626	1 to 30, 31	1
A017	—	Easy sequence function enable	R/W	00..Disable 01..Enable	1213h	04627	0, 1	—
—		(Reserved)	—	—	1214h	04628	—	—
A019	—	Multi-speed operation selection	R/W	00..Binary; up to 16-stage speed using 4 terminals 01..Single-bit; up to 8-stage speed using 7 terminals	1215h	04629	0, 1	—
A020	H	Multi-speed frequency setting	R/W	Defines the first speed of a multi-speed profile	1216h	04630	0 or start freq. to max. freq.	0.01 Hz
A020	L				1217h	04631		
A220	H	Multi-speed frequency setting, 2nd motor	R/W	Defines the first speed of a multi-speed profile for 2nd motor	2216h	08726	0 or start freq. to max. freq.	0.01 Hz
A220	L				2217h	08727		
—		(Reserved)	—	—	2218h to 223Ah	08728 to 08762	—	—
A320	H	Multi-speed frequency setting, 3rd motor	R/W	Defines the first speed of a multi-speed profile for 3rd motor	3216h	12822	0 or start freq. to max. freq.	0.01 Hz
A320	L				3217h	12823		
—		(Reserved)	—	—	3218h to 323Bh	12824 to 12859	—	—
A021	H	Multi-speed 1 setting	R/W	Defines nth additional speed	1218h	04632	0 or start freq. to max. freq.	0.01 Hz
A021	L				1219h	04633		
A022	H	Multi-speed 2 setting	R/W	Defines nth additional speed	121Ah	04634	0 or start freq. to max. freq.	0.01 Hz
A022	L				121Bh	04635		
A023	H	Multi-speed 3 setting	R/W	Defines nth additional speed	121Ch	04636	0 or start freq. to max. freq.	0.01 Hz
A023	L				121Dh	04637		

Holding Registers, "A" Group Standard Functions								
Func. Code	Name	R/W	Description	Network Data				
				Register		Range	Res.	
				hex	dec.			
A024	H	Multi-speed 4 setting	R/W	Defines nth additional speed	121Eh	04638	0 or start freq. to max. freq.	0.01 Hz
A024	L				121Fh	04639		
A025	H	Multi-speed 5 setting	R/W	Defines nth additional speed	1220h	04640	0 or start freq. to max. freq.	0.01 Hz
A025	L				1221h	04641		
A026	H	Multi-speed 6 setting	R/W	Defines nth additional speed	1222h	04642	0 or start freq. to max. freq.	0.01 Hz
A026	L				1223h	04643		
A027	H	Multi-speed 7 setting	R/W	Defines nth additional speed	1224h	04644	0 or start freq. to max. freq.	0.01 Hz
A027	L				1225h	04645		
A028	H	Multi-speed 8 setting	R/W	Defines nth additional speed	1226h	04646	0 or start freq. to max. freq.	0.01 Hz
A028	L				1227h	04647		
A029	H	Multi-speed 9 setting	R/W	Defines nth additional speed	1228h	04648	0 or start freq. to max. freq.	0.01 Hz
A029	L				1229h	04649		
A030	H	Multi-speed 10 setting	R/W	Defines nth additional speed	122Ah	04650	0 or start freq. to max. freq.	0.01 Hz
A030	L				122Bh	04651		
A031	H	Multi-speed 11 setting	R/W	Defines nth additional speed	122Ch	04652	0 or start freq. to max. freq.	0.01 Hz
A031	L				122Dh	04653		
A032	H	Multi-speed 12 setting	R/W	Defines nth additional speed	122Eh	04654	0 or start freq. to max. freq.	0.01 Hz
A032	L				122Fh	04655		
A033	H	Multi-speed 13 setting	R/W	Defines nth additional speed	1230h	04656	0 or start freq. to max. freq.	0.01 Hz
A033	L				1231h	04657		
A034	H	Multi-speed 14 setting	R/W	Defines nth additional speed	1232h	04658	0 or start freq. to max. freq.	0.01 Hz
A034	L				1233h	04659		
A035	H	Multi-speed 15 setting	R/W	Defines nth additional speed	1234h	04660	0 or start freq. to max. freq.	0.01 Hz
A035	L				1235h	04661		
—		(Reserved)	—	—	1236h	04662	—	—
—		(Reserved)	—	—	1237h	04663	—	—
A038	—	Jog frequency setting	R/W	Defines limited speed for jog	1238h	04664	0 to 999	0.01 Hz

Holding Registers, "A" Group Standard Functions								
Func. Code	Name	R/W	Description	Network Data				
				Register		Range	Res.	
				hex	dec.			
A039	Jog stop mode	R/W	00..Free-run stop, jogging disabled during motor run 01..Controlled deceleration, jogging disabled during motor run 02..DC braking to stop, jogging disabled during motor run 03..Free-run stop, jogging always enabled 04..Controlled deceleration, jogging always enabled 05..DC braking to stop, jogging always enabled	1239h	04665	0 to 5	—	
—	(Reserved)	—	—	123Ah	04666	—	—	
A041	Torque boost method selection	R/W	00..Manual torque boost 01..Automatic torque boost	123Bh	04667	0, 1	—	
A241	Torque boost method selection, 2nd motor	R/W	00..Manual torque boost 01..Automatic torque boost	223Bh	08763	0, 1	—	
A042	Manual torque boost value	R/W	Can boost starting torque between 0 and 20% above normal V/f curve	123Ch	04668	0 to 200	0.1 %	
A242	Manual torque boost value, 2nd motor	R/W	Can boost starting torque between 0 and 20% above normal V/f curve	223Ch	08764	0 to 200	0.1 %	
A342	Manual torque boost value, 3rd motor	R/W	Can boost starting torque between 0 and 20% above normal V/f curve	323Ch	12860	0 to 200	0.1 %	
A043	Manual torque boost frequency adjustment	R/W	Sets the frequency of the V/f breakpoint for torque boost	123Dh	04669	0 to 500	0.1 %	
A243	Manual torque boost frequency adjustment, 2nd motor	R/W	Sets the frequency of the V/f breakpoint for torque boost	223Dh	08765	0 to 500	0.1 %	
A343	Manual torque boost frequency adjustment, 3rd motor	R/W	Sets the frequency of the V/f breakpoint for torque boost	323Dh	12861	0 to 500	0.1 %	
A044	V/F characteristic curve selection	R/W	00..V/f constant torque 01..V/f variable torque 02..V/f free-setting curve 03..Sensorless vector SLV 04..0Hz domain SLV 05..Vector control with encoder feedback	123Eh	04670	0 to 5	—	
A244	V/F characteristic curve selection, 2nd motor	R/W	00..V/f constant torque 01..V/f variable torque 02..V/f free-setting curve 03..Sensorless vector SLV 04..0Hz domain SLV	223Eh	08766	0 to 4	—	
—	(Reserved)	—	—	223Fh	08767	—	—	
A344	V/F characteristic curve selection, 3rd motor	R/W	00..V/f constant torque 01..V/f variable torque	323Eh	12862	0, 1	—	

Holding Registers, "A" Group Standard Functions								
Func. Code	Name	R/W	Description	Network Data				
				Register		Range	Res.	
				hex	dec.			
—	(Reserved)	—	—	323Fh to 326Ch	12863 to 12908	—	—	
A045	—	V/f gain setting	R/W	Sets voltage gain of the inverter	123Fh	04671	20 to 200	1 %
A046	—	Automatic torque boost voltage gain	R/W	Voltage compensation gain for automatic torque boost	1240h	04672	0 to 255	1
A246	—	Automatic torque boost voltage gain, 2nd motor	R/W	Voltage compensation gain for automatic torque boost	2240h	08768	0 to 255	1
A047	—	Automatic torque boost slip gain	R/W	Slip compensation gain for automatic torque boost	1241h	04673	0 to 255	1
—	(Reserved)	—	—	1242h to 1244h	04674 to 04676	—	—	
A247	—	Automatic torque boost slip gain, 2nd motor		Slip compensation gain for automatic torque boost	2241h	08769	0 to 255	1
—	(Reserved)	—	—	2242h to 224Eh	08770 to 08782	—	—	
A051	—	DC braking enable	R/W	00 . Disable 01 . Enable 02 . Brake at set frequency only	1245h	04677	0, 1, 2	—
A052	—	DC braking frequency setting	R/W	Frequency at which DC braking activates during decel.	1246h	04678	0 to 40000	0.01 Hz
A053	—	DC braking wait time	R/W	The delay after reaching the DC braking frequency, or [DB] signal, before DC braking begins	1247h	04679	0 to 50	0.1 sec.
A054	—	DC braking force during deceleration	R/W	Variable DC braking force	1248h	04680	0 to 80	1 %
A055	—	DC braking time for deceleration	R/W	Sets the duration for DC braking during decel	1249h	04681	0 to 600	0.1 sec.
A056	—	DC braking / edge or level detection for [DB] input	R/W	00 . Edge detection 01 . Level detection	124Ah	04682	0, 1	—
A057	—	DC braking force for starting	R/W	Variable DC braking force	124Bh	04683	0 to 80	1 %
A058	—	DC braking time for starting	R/W	Sets the duration for DC braking before accel.	124Ch	04684	0 to 600	0.1 sec.
A059	—	DC braking carrier frequency setting	R/W	0.5 to 15 (kHz) for models up to -550xxx, 0.5 to 10 (kHz) for 750xxx to 1500xxx models	124Dh	04685	5 to 150; 5 to 100	0.1 kHz
—	(Reserved)	—	—	124Eh	04686	—	—	
A061	H	Frequency upper limit setting	R/W	Sets a limit on output frequency less than the maximum frequency (A004)	124Fh	04687	0, 50 to 40000	0.01 Hz
A061	L				1250h	04688		

Holding Registers, "A" Group Standard Functions								
Func. Code		Name	R/W	Description	Network Data			
					Register		Range	Res.
					hex	dec.		
A261	H	Frequency upper limit setting, 2nd motor	R/W	Sets a limit on output frequency less than the maximum frequency (A004)	224Fh	08783	0, 50 to 40000	0.01 Hz
A261	L		R/W		2250h	08784		
A062	H	Frequency lower limit setting	R/W	Sets a limit on output frequency greater than zero	1251h	04689	0, 50 to 40000	0.01 Hz
A062	L		R/W		1252h	04690		
A262	H	Frequency lower limit setting, 2nd motor	R/W	Sets a limit on output frequency greater than zero	2251h	08785	0, 50 to 40000	0.01 Hz
A262	L		R/W		2252h	08786		
—	—	(Reserved)	—	—	2253h to 226Eh	08787 to 08814	—	—
A063	H	Jump (center) frequency setting	R/W	Up to 3 output frequencies can be defined for the output to jump past to avoid motor resonances (center freq.)	1253h	04691	0 to 40000	0.01 Hz
A063	L		R/W		1254h	04692		
A064	—	Jump (hysteresis) frequency width setting	R/W	Defines the distance from the center frequency at which the jump occurs	1255h	04693	0 to 1000	0.01 Hz
A065	H	Jump (center) frequency setting	R/W	Up to 3 output frequencies can be defined for the output to jump past to avoid motor resonances (center freq.)	1256h	04694	0 to 40000	0.01 Hz
A065	L		R/W		1257h	04695		
A066	—	Jump (hysteresis) frequency width setting	R/W	Defines the distance from the center frequency at which the jump occurs	1258h	04696	0 to 1000	0.01 Hz
A067	H	Jump (center) frequency setting	R/W	Up to 3 output frequencies can be defined for the output to jump past to avoid motor resonances (center freq.)	1259h	04697	0 to 40000	0.01 Hz
A067	L		R/W		125Ah	04698		
A068	—	Jump (hysteresis) frequency width setting	R/W	Defines the distance from the center frequency at which the jump occurs	125Bh	04699	0 to 1000	0.01 Hz
A069	H	Acceleration stop frequency setting	R/W	0.00 to 400.0 (Hz)	125Ch	04700	0 to 40000	0.01 Hz
A069	L		R/W		125Dh	04701		
A070	—	Acceleration stop time frequency setting	R/W	0.0 to 60.0 (seconds)	125Eh	04702	0 to 600	0.1 sec.
A071	—	PID Function Enable	R/W	00..PID operation OFF 01..PID operation ON 02..PID operation ON with inverted output	125Fh	04703	0, 1, 2	—
A072	—	PID proportional gain	R/W	0.2 to 5.0	1260h	0474	2 to 50	0.2
A073	—	PID integral time constant	R/W	0.0 to 999.9, 1000. to 3600. (seconds)	1261h	04705	0 to 36000	0.1 sec.
A074	—	PID derivative gain	R/W	0.0 to 99.99, 100.0 (seconds)	1262h	04706	0 to 10000	0.01 sec.
A075	—	PV scale conversion	R/W	0.01 to 99.99, 100.0 (seconds)	1263h	04707	1 to 9999	0.01

Holding Registers, "A" Group Standard Functions								
Func. Code	Name	R/W	Description	Network Data				
				Register		Range	Res.	
				hex	dec.			
A076	—	PV source setting	R/W	00 . [OI] (current input) 01 . [O] (voltage input) 02 . Communication input 03 . Pulse train freq. input 10 . Calculate function output	1264h	04708	0 to 3, 10	—
A077	—	Reverse PID action	R/W	00 . PID input = SP – PV (normal) 01 . PID input = –(SP – PV) (reverse)	1265h	04709	0, 1	—
A078	—	PID output limit	R/W	Range is 0.0 to 100.0	1266h	04710	0 to 1000	0.1 sec.
A079	—	PID feed forward select	R/W	00 . Disable 01 . [O] (voltage input) 02 . [OI] (current input) 03 . [O2] (voltage input)	1267h	04711	0 to 3	—
—	—	(Reserved)	—	—	1268h	04712	—	—
A081	—	AVR function select	R/W	00 . AVR enabled 01 . AVR disabled 02 . AVR enabled except during deceleration	1269h	04713	0, 1, 2	—
A082	—	AVR voltage select	R/W	200V class inverter settings: 200/215/220/230/240 (V) 400V class inverter settings: 380/400/415/440/460/480 (V)	126Ah	04714	—	—
—	—	(Reserved)	—	—	126Bh	04715	—	—
—	—	(Reserved)	—	—	126Ch	04716	—	—
A085	—	Operation mode selection	R/W	00 . Normal operation 01 . Energy-saver operation 02 . Optimal accel/decel operation	126Dh	04717	0, 1, 2	—
A086	—	Energy saving mode tuning	R/W	0.0 to 100 (seconds)	126Eh	04718	0 to 1000	0.1 %
—	—	(Reserved)	—	—	126Fh to 1273h	04719 to 04723	—	—
A092	H	Acceleration (2) time setting	R/W	Duration of 2nd segment of acceleration	1274h	04724	1 to 360000	0.01 sec.
A092	L		R/W		1275h	04725		
A292	H	Acceleration (2) time setting, 2nd motor	R/W	Duration of 2nd segment of acceleration, 2nd motor	226Fh	08815	1 to 360000	0.01 sec.
A292	L		R/W		2270h	08816		
A392	H	Acceleration (2) time setting, 3rd motor	R/W	Duration of 2nd segment of acceleration, 3rd motor	326Dh	12909	1 to 360000	0.01 sec.
A392	L		R/W		326Eh	12910		
A093	H	Deceleration (2) time setting	R/W	Duration of 2nd segment of deceleration	1276h	04726	1 to 360000	0.01 sec.
A093	L		R/W		1277h	04727		
A293	H	Deceleration (2) time setting, 2nd motor	R/W	Duration of 2nd segment of deceleration, 2nd motor	2271h	08817	1 to 360000	0.01 sec.
A293	L		R/W		2272h	08818		
A393	H	Deceleration (2) time setting, 3rd motor	R/W	Duration of 2nd segment of deceleration, 3rd motor	326Fh	12911	1 to 360000	0.01 sec.
A393	L		R/W		3270h	12912		

Holding Registers, "A" Group Standard Functions								
Func. Code	Name	R/W	Description	Network Data				
				Register		Range	Res.	
				hex	dec.			
—	(Reserved)	—	—	3271h to 330Bh	12913 to 13067	—	—	
A094	—	R/W	00..[2CH] terminal input 01..transition frequency 02..when motor direction reverses	1278h	04728	0, 1, 2	—	
A294	—	R/W	00..[2CH] terminal input 01..transition frequency 02..when motor direction reverses	2273h	08819	0, 1, 2	—	
A095	H	R/W	Acc1 to Acc2 frequency transition point	1279h	04729	0 to 40000	0.01 Hz	
A095	L	R/W		127Ah	04730			
A295	H	R/W	Acc1 to Acc2 frequency transition point, 2nd motor	2274h	08820	0 to 40000	0.01 Hz	
A295	L	R/W		2275h	08821			
A096	H	R/W	Dec1 to Dec2 frequency transition point	127Bh	04731	0 to 40000	0.01 Hz	
A096	L	R/W		127Ch	04732			
A296	H	R/W	Dec1 to Dec2 frequency transition point, 2nd motor	2276h	08822	0 to 40000	0.01 Hz	
A296	L	R/W		2277h	08823			
—	(Reserved)	—	—	2278h to 230Bh	08824 to 08971	—	—	
A097	—	R/W	00..Linear 01..S-curve 02..U-shape 03..Reverse U-shape 04..EL-S curve	127Dh	04733	0 to 4	—	
A098	—	R/W	00..Linear 01..S-curve 02..U-shape 03..Reverse U-shape 04..EL-S curve	127Eh	04734	0 to 4	—	
—	(Reserved)	—	—	127Fh	04735	—	—	
—	(Reserved)	—	—	1280h	04736	—	—	
A101	H	R/W	[OI]-[L] input active range start frequency	1281h	04637	0 to 40000	0.01 Hz	
A101	L	R/W		1282h	04738			
A102	H	R/W	[OI]-[L] input active range end frequency	1283h	04739	0 to 40000	0.01 Hz	
A102	L	R/W		1284h	04740			
A103	—	R/W	[OI]-[L] input active range start current	1285h	04741	0 to A104 value	1 %	
A104	—	R/W	[OI]-[L] input active range end current	1286h	04742	A103 value to 100	1 %	
A105	—	R/W	00..Use A101 start value 01..Use 0Hz	1287h	04743	0, 1	—	

Holding Registers, "A" Group Standard Functions								
Func. Code	Name	R/W	Description	Network Data				
				Register		Range	Res.	
				hex	dec.			
—	(Reserved)	—	—	1288h to 128Ch	04744 to 0448	—	—	
A111	H	[O2]–[L] input active range start frequency	R/W	Output frequency corresponding to the bipolar voltage input range starting point	128Dh	04749	-40000 to 40000	0.01 Hz
A111	L		R/W		128Eh	04750		
A112	H	[O2]–[L] input active range end frequency	R/W	Output frequency corresponding to the bipolar voltage input range ending point	128Fh	04751	-40000 to 40000	0.01 Hz
A112	L		R/W		1290h	04752		
A113	—	[O2]–[L] input active range start voltage	R/W	Starting point for the bipolar voltage input range	1291h	04753	-100 to A114 value	1 %
A114	—	[O2]–[L] input active range end voltage	R/W	Ending point for the bipolar voltage input range	1292h	04754	A113 value to 100	1 %
—	(Reserved)	—	—	—	1293h to 12A4h	04755 to 04772	—	—
A131	—	Acceleration curve constants setting	R/W	Sets the curve deviation from straight-line acceleration in 10 levels (01 to 10)	12A5h	04773	1 to 10	—
A132	—	Deceleration curve constants setting	R/W	Sets the curve deviation from straight-line deceleration in 10 levels (01 to 10)	12A6h	04774	1 to 10	—
—	(Reserved)	—	—	—	12A7h to 12AEh	04775 to 04782	—	—
A141	—	A input select for calculate function	R/W	00 . Digital operator (A020/A220/A320) 01 . Keypad potentiometer 02 . [O] input 03 . [OI] input 04 . Comm. port 05 . Expansion card 1 06 . Expansion card 2 07 . Pulse train frequency train input	12AFh	04783	0 to 7	—
A142	—	B input select for calculate function	R/W	00 . Digital operator (A020/A220/A320) 01 . Keypad potentiometer 02 . [O] input 03 . [OI] input 04 . Comm. port 05 . Expansion card 1 06 . Expansion card 2 07 . Pulse train frequency train input	12B0h	04784	0 to 7	—
A143	—	Calculation symbol	R/W	00 . ADD (A input + B input) 01 . SUB (A input – B input) 02 . MUL (A input x B input)	12B1h	04785	0, 1, 2	—
—	(Reserved)	—	—	—	12B2h	04786	—	—

Holding Registers, "A" Group Standard Functions								
Func. Code		Name	R/W	Description	Network Data			
					Register		Range	Res.
					hex	dec.		
A145	H	ADD frequency	R/W	0.00 to 99.99, 100.0 to 400.0 (Hz)	12B3h	04787	0 to 40000	0.01 Hz
A145	L		R/W		12B4h	04788		
A146	—	ADD direction select	R/W	00..Plus (adds A145 value to output frequency) 01..Minus (subtracts A145 value from output freq.)	12B5h	04789	0, 1	—
—	—	(Reserved)	—	—	12B6h to 12B8h	04790 to 04792	—	—
A150	—	EL-S curve acceleration ratio 1	R/W	Range is 0. to 50.	12B9h	04793	0 to 50	1 %
A151	—	EL-S curve acceleration ratio 2	R/W	Range is 0. to 50.	12BAh	04794	0 to 50	1 %
A152	—	EL-S curve acceleration ratio 3	R/W	Range is 0. to 50.	12BBh	04795	0 to 50	1 %
A153	—	EL-S curve acceleration ratio 4	R/W	Range is 0. to 50.	12BCh	04796	0 to 50	1 %
—	—	(Reserved)	—	—	12BDh to 1300h	04797 to 04864	—	—

Holding Registers, "B" Group Fine Tuning Functions								
Func. Code		Name	R/W	Description	Network Data			
					Register		Range	Res.
					hex	dec.		
B001	—	Selection of restart mode	R/W	00. Alarm output after trip, automatic restart disabled 01. Resume operation after frequency matching 02. Resume operation after frequency matching 03. Resume previous freq. after freq. matching, then decelerate to stop and display trip info 04. Restart with active matching frequency	1301h	04865	0 to 4	—
B002	—	Allowable under-voltage power failure time	R/W	The amount of time a power input under-voltage can occur without tripping the power failure alarm	1302h	04866	3 to 250	0.1 sec.

Holding Registers, "B" Group Fine Tuning Functions								
Func. Code	Name	R/W	Description	Network Data				
				Register		Range	Res.	
				hex	dec.			
B003	—	Retry wait time before motor restart	R/W	Time delay after a trip condition goes away before the inverter restarts the motor	1303h	04867	3 to 1000	0.1 sec.
B004	—	Instantaneous power failure / under-voltage trip alarm enable	R/W	00 .Disable 01 .Enable 02 .Disable during stop and ramp to stop	1304h	04868	0, 1, 2	—
B005	—	Number of restarts on power failure / under-voltage trip events	R/W	00 .Restart 16 times 01 .Always restart	1305h	04869	0, 1	—
B006	—	Phase loss detection enable	R/W	00 .Disable 01 .Enable	1306h	04870	0, 1	—
B007	H	Restart frequency threshold	R/W	When the frequency of the motor is less than this value, the inverter will restart at 0 Hz	1307h	04871	0 to 40000	0.01 Hz
B007	L		R/W		1308h	04872		
B008	—	Retry after trip select	R/W	00 .Always retry after trip 01 .Start with 0 Hz 02 .Start with frequency matching 03 .Retry after deceleration and stop with matching frequency 04 .Start with active matching frequency	1309h	04873	0 to 4	—
B009	—	Retry after undervoltage select	R/W	00 .Restart 16 times 01 .Unlimited	130Ah	04874	0, 1	—
B010	—	Retry count select after overvoltage or overcurrent	R/W	1 to 3 (times)	130Bh	04875	1 to 3	times
B011	—	Retry wait time after trip	R/W	0.3 to 100.0 (seconds)	130Ch	04876	3 to 1000	0.1 sec.
B012	—	Electronic thermal setting (calculated within the inverter from current output)	R/W	Range is 0.2 * rated current to 1.2 * rated current	130Dh	04877	200 to 1000	0.1 %
B212	—	Electronic thermal setting (calculated within the inverter from current output), 2nd motor	R/W	Range is 0.2 * rated current to 1.2 * rated current	230Ch	08972	200 to 1000	0.1 %
B312	—	Electronic thermal setting (calculated within the inverter from current output), 3rd motor	R/W	Range is 0.2 * rated current to 1.2 * rated current	330Ch	13068	200 to 1000	0.1 %
B013	—	Electronic thermal characteristic	R/W	00 .Reduced torque 01 .Constant torque 02 .Free-setting	130Eh	04878	0, 1, 2	—
—	—	(Reserved)	—	—	130Fh	04879	—	—
B213	—	Electronic thermal characteristic, 2nd motor	R/W	00 .Reduced torque 01 .Constant torque 02 .Free-setting	230Dh	08973	0, 1, 2	—
—	—	(Reserved)	—	—	230Eh to 2501h	08974 to 09493	—	—

Holding Registers, "B" Group Fine Tuning Functions								
Func. Code	Name	R/W	Description	Network Data				
				Register		Range	Res.	
				hex	dec.			
B313	—	Electronic thermal characteristic, 3rd motor	R/W	00 . Reduced torque 01 . Constant torque 02 . Free-setting	330Dh	13069	0, 1, 2	—
—	—	(Reserved)	—	—	330Eh to 3506h	13070 to 13574	—	—
B015	—	Free setting, electronic thermal frequency (1)	R/W	Data point coordinates for Hz axis (horizontal) in the free-form curve	1310h	04880	0 to 400	1 Hz
B016	—	Free setting, electronic thermal current (1)	R/W	Data point coordinates for Ampere axis (vertical) in the free-form curve	1311h	04881	0 to rated current	0.1 A
B017	—	Free setting, electronic thermal frequency (2)	R/W	Data point coordinates for Hz axis (horizontal) in the free-form curve	1312h	04882	0 to 400	1 Hz
B018	—	Free setting, electronic thermal current (2)	R/W	Data point coordinates for Ampere axis (vertical) in the free-form curve	1313h	04883	0 to rated current	0.1 A
B019	—	Free setting, electronic thermal frequency (3)	R/W	Data point coordinates for Hz axis (horizontal) in the free-form curve	1314h	04884	0 to 400	1 Hz
B020	—	Free setting, electronic thermal current (3)	R/W	Data point coordinates for Ampere axis (vertical) in the free-form curve	1315h	04885	0 to rated current	0.1 A
B021	—	Overload restriction operation mode	R/W	00 . Disable 01 . Enable for acceleration and constant speed 02 . Enable for constant speed only 03 . Enable for accel, decel, and constant speed	1316h	04886	0 to 3	—
B022	—	Overload restriction setting	R/W	(0.20 x rated current) to (1.80 x rated current) (A)	1317h	04887	200 to 2000	0.1 %
B023	—	Deceleration rate at overload restriction	R/W	0.10 to 30.00 (seconds)	1318h	04888	10 to 3000	0.1 sec.
B024	—	Overload restriction operation mode (2)	R/W	00 . Disable 01 . Enable for acceleration and constant speed 02 . Enable for constant speed only 03 . Enable for accel, decel, and constant speed	1319h	04889	0 to 3	—
B025	—	Overload restriction setting (2)	R/W	(0.20 x rated current) to (1.80 x rated current) (A)	131Ah	04890	200 to 2000	0.1 %
B026	—	Deceleration rate at overload restriction (2)	R/W	0.10 to 30.00 (seconds)	131Bh	04891	1 to 3000	0.01 sec.
B027	—	Overcurrent suppression enable	R/W	00 . Disable 01 . Enable	131Ch	04892	0, 1	—
B028	—	Current limit for active frequency-matching restart	R/W	(0.20 x rated current) to (1.80 x rated current) (A)	131Dh	04893	200 to 2000	0.1 %

Holding Registers, "B" Group Fine Tuning Functions								
Func. Code	Name	R/W	Description	Network Data				
				Register		Range	Res.	
				hex	dec.			
B029	—	Scan time constant for active freq. matching	R/W	10 to 3000	131Eh	04894	0.01 sec.	0.01 sec.
B030	—	Restart freq. select for active freq. matching	R/W	00 .Frequency at last shutoff 01 .Maximum frequency 02 .Set frequency	131Fh	04895		
B031	—	Software lock mode selection	R/W	00 .Low-level access, [SFT] input blocks all edits 01 .Low-level access, [SFT] input blocks edits (except F001 and Multi-speed parameters) 02 .No access to edits 03 .No access to edits except F001 and Multi-speed parameters 10 .High-level access, including B031	1320h	04896		
—		(Reserved)	—	—	1321h	04897	—	—
—		(Reserved)	—	—	1322h	04898	—	—
B034	H	Run/power-on warning time	R/W	0 to 9999. (0 to 99990), 1000 to 6553 (10000 to 655300) (hours)	1323h	04899	0 to 65535	1 [10-hours]
B034	L		R/W		1324h	04900		
B035	—	Rotational direction restriction	R/W	00 .Enable for fwd. and rev. 01 .Enable for forward only 02 .Enable for reverse only	1325h	04901	0, 1, 2	—
B036	—	Reduced voltage start selection	R/W	000 (short) to 255 (long)	1326h	04902	0 to 255	—
B037	—	Function code display restriction	R/W	00 .Display all 01 .Display only utilized functions 02 .Display user-selected functions only 03 .Data comparison display 04 .Basic display	1327h	04903	0 to 4	—
B038	—	Initial display selection	R/W	00 .Last value displayed when STR key was pressed 01 .D001 02 .D002 03 .D003 04 .D007 05 .F001	1328h	04904	0 to 5	—
B039	—	Automatic user parameter function enable	R/W	00 .Disable 01 .Enable	1329h	04905	0, 1	—
B040	—	Torque limit selection	R/W	00 .4-quadrant mode 01 .Selected by two input terminals 02 .From analog [O2] input 03 .From expansion card 1 04 .From expansion card 2	132Ah	04906	0 to 4	—
B041	—	Torque limit (1) (forward-driving in 4-quadrant mode)	R/W	0. to 200. (%), no (disable torque limit)	132Bh	04907	0 to 200, 255= (no)	1 %

Holding Registers, "B" Group Fine Tuning Functions								
Func. Code	Name	R/W	Description	Network Data				
				Register		Range	Res.	
				hex	dec.			
B042	—	Torque limit (2) (reverse-regenerating in 4-quadrant mode)	R/W	0. to 200. (%), no (disable torque limit)	132Ch	04908	0 to 200, 255= (no)	1 %
B043	—	Torque limit (3) (reverse-driving in 4-quadrant mode)	R/W	0. to 200. (%), no (disable torque limit)	132Dh	04909	0 to 200, 255= (no)	1 %
B044	—	Torque limit (4) (forward-regenerating in 4-quadrant mode)	R/W	0. to 200. (%), no (disable torque limit)	132Eh	04910	0 to 200, 255= (no)	1 %
B045	—	Torque limit LADSTOP enable	R/W	00 . Disable 01 . Enable	132Fh	04911	0, 1	—
B046	—	Reverse Run protection enable	R/W	00 . Disable 01 . Enable	1330h	04912	0, 1	—
—		(Reserved)	—	—	1331h to 1333h	04913 to 04915	—	—
B050	—	Controller deceleration and stop on power loss	R/W	00 . Disable 01 . Constant decel to stop 02 . Constant DC voltage control with resume 03 . Constant DC voltage control	1334h	04916	0 to 3	—
B051	—	DC bus voltage trigger level during power loss	R/W	Sets trigger for controlled deceleration and stop on power loss function	1335h	04917	0 to 10000	0.1 V
B052	—	Over-voltage threshold during power loss	R/W	Sets over-voltage threshold for controlled deceleration function	1336h	04918	0 to 10000	0.1 V
B053	H	Deceleration time setting during power loss	R/W	0.01 to 99.99, 100.0 to 999.9, 1000 to 3600 (seconds)	1337h	04919	0 to 360000	0.01 sec.
B053	L		R/W		1338h	04920		
B054	—	Initial output frequency decrease during power loss	R/W	Sets the initial decrease in output frequency upon power loss	1339h	04921	0 to 1000	0.01 Hz
B055	—	Proportional gain setting for non-stop operation at power loss	R/W	0.00 to 2.55	133Ah	04922	0 to 255	0.01
B056	—	Integral time setting for non-stop operation at power loss	R/W	0.0 to 9.999, 10.00 to 65.55	133Bh	04923	0 to 65535	0.001 sec.
—		(Reserved)	—	—	133Ch to 133Eh	04924 to 04926	—	—
B060	—	[O] input max. limit level of window comparator	R/W	0. to 100. (%) Lower limit = B061 + B062 / 2	133Fh	04927	0 to 100	1 %
B061	—	[O] input min. limit level of window comparator	R/W	0. to 100. (%) Lower limit = B060 – B062 / 2	1340h	04928	0 to 100	1 %
B062	—	[O] input hysteresis width of window comparator	R/W	0. to 10. (%) Lower limit = B061 – B062 / 2	1341h	04929	0 to 10	1 %
B063	—	[OI] input max. limit level of window comparator	R/W	0. to 100. (%) Lower limit = B064 + B066 / 2	1342h	04930	0 to 100	1 %

Holding Registers, "B" Group Fine Tuning Functions								
Func. Code	Name	R/W	Description	Network Data				
				Register		Range	Res.	
				hex	dec.			
B064	[OI] input min. limit level of window comparator	R/W	0. to 100. (%) Lower limit = B063 – B066 / 2	1343h	04931	0 to 100	1 %	
B065	[OI] input hysteresis width of window comparator	R/W	0. to 10. (%) Lower limit = B063 – B064 / 2	1344h	04932	0 to 10	1 %	
B066	[O/OI/O2] input maximum limit level of window comparator	R/W	–100. to 100. (%) Lower limit = B067 + B068 / 2	1345h	04933	0 to 100	1 %	
B067	[O/OI/O2] input minimum limit level of window comparator	R/W	–100. to 100. (%) Lower limit = B066 – B068 / 2	1346h	04934	0 to 100	1 %	
B068	[O/OI/O2] input hysteresis width of window comparator	R/W	0. to 10. (%) Lower limit = B066 – B067 / 2	1347h	04935	0 to 10	1 %	
—	(Reserved)	—	—	1348h	04936	—	—	
B070	[O] input disconnect threshold	R/W	0 to 100 (%); 255 = ignore setting	1349h	04937	0 to 100, 255	1 %	
B071	[OI] input disconnect threshold	R/W	0 to 100 (%); 255 = ignore setting	134Ah	04938	0 to 100, 255	1 %	
B072	[O2] input disconnect threshold	R/W	0 to 100 (%); 255 = ignore setting	134Bh	04939	0 to 100, 255	1 %	
—	(Reserved)	—	—	134Ch to 1350h	04940 to 04944	—	—	
B078	Clear cumulative input power data	R/W	00 .No change 01 .Clear the data	1351h	04945	0, 1	—	
B079	Cumulative input power display gain setting	R/W	1. to 1000.	1352h	04946	1 to 1000	1	
—	(Reserved)	—	—	1353h	04947	—	—	
—	(Reserved)	—	—	1354h	04948	—	—	
B082	Start frequency adjustment	R/W	0.10 to 9.99 (Hz)	1355h	04949	10 to 999	0.01 Hz	
B083	Carrier frequency setting	R/W	Sets the PWM carrier (internal switching frequency)	1356h	04950	5 to 150	0.1 kHz	
B084	Initialization mode (parameters or trip history)	R/W	00 .Trip history clear 01 .Parameter initialization 02 .Trip history clear and parameter initialization	1357h	04951	0, 1, 2	—	
B085	Country code for initialization	R/W	00 .Japan version 01 .Europe version 02 .USA version	1358h	04952	0, 1, 2	—	
B086	Frequency scaling conversion factor	R/W	Specify a constant to scale D007 to display in engineering units	1359h	04953	1 to 999	0.1	
B087	STOP key enable	R/W	00 .Enable 01 .Disable 02 .Disable only the STOP function	135Ah	04954	0, 1, 2	—	

Holding Registers, "B" Group Fine Tuning Functions								
Func. Code	Name	R/W	Description	Network Data				
				Register		Range	Res.	
				hex	dec.			
B088	Restart mode after FRS	R/W	00 . Restart from 0Hz 01 . Restart from frequency detected from actual speed of motor 02 . Restart from active matching frequency	135Bh	04955	0, 1, 2	—	
—	(Reserved)	—	—	135Ch	04956	—	—	
B090	Dynamic braking usage ratio	R/W	0.0 to 100.0 (%) Set = 0.0 to disable dynamic braking	135Dh	04957	0 to 1000	0.1 %	
B091	Stop mode selection	R/W	00 . DEC (decelerate and stop) 01 . FRS (free run to stop)	135Eh	04958	0, 1	—	
B092	Cooling fan control	R/W	00 . Fan always ON 01 . Fan ON during RUN, OFF during STOP	135Fh	04959	0, 1	—	
—	(Reserved)	—	—	1360h	04960	—	—	
—	(Reserved)	—	—	1361h	04961	—	—	
B095	Dynamic braking control	R/W	00 . Disable 01 . Enable during RUN only 02 . Enable always	1362h	04962	0, 1, 2	—	
B096	Dynamic braking activation level	R/W	330 to 380 (V) (200V class), 660 to 760 (V) (400V class)	1363h	04963	330 to 380 660 to 760	1 V	
—	(Reserved)	—	—	1364h	04964	—	—	
B098	Thermistor for thermal protection control	R/W	00 . Disable 01 . Enable-PTC thermistor 02 . Enable-NTC thermistor	1365h	04965	0, 1, 2	—	
B099	Thermal protection level setting	R/W	Thermistor resistance threshold at which trip occurs	1366h	04966	0 to 9999	1 Ω	
B100	Free-setting V/f freq. (1)	R/W	0. to Free-setting V/f freq. (2)	1367h	04967	0 to V/f 2	1 Hz	
B101	Free-setting V/f voltage (1)	R/W	0.0 to 800.0 (V)	1368h	04968	0 to 8000	0.1 V	
B102	Free-setting V/f freq. (2)	R/W	0. to Free-setting V/f freq. (3)	1369h	04969	0 to V/f 3	1 Hz	
B103	Free-setting V/f voltage (2)	R/W	0.0 to 800.0 (V)	136Ah	04970	0 to 8000	0.1 V	
B104	Free-setting V/f freq. (3)	R/W	0. to Free-setting V/f freq. (4)	136Bh	04971	0 to V/f 4	1 Hz	
B105	Free-setting V/f voltage (3)	R/W	0.0 to 800.0 (V)	136Ch	04972	0 to 8000	0.1 V	
B106	Free-setting V/f freq. (4)	R/W	0. to Free-setting V/f freq. (5)	136Dh	04973	0 to V/f 5	1 Hz	
B107	Free-setting V/f voltage (4)	R/W	0.0 to 800.0 (V)	136Eh	04974	0 to 8000	0.1 V	
B108	Free-setting V/f freq. (5)	R/W	0. to Free-setting V/f freq. (6)	136Fh	04975	0 to V/f 6	1 Hz	
B109	Free-setting V/f voltage (5)	R/W	0.0 to 800.0 (V)	1370h	04976	0 to 8000	0.1 V	
B110	Free-setting V/f freq. (6)	R/W	0. to Free-setting V/f freq. (7)	1371h	04977	0 to V/f 7	1 Hz	
B111	Free-setting V/f voltage (6)	R/W	0.0 to 800.0 (V)	1372h	04978	0 to 8000	0.1 V	
B112	Free-setting V/f freq. (7)	R/W	0. to 400.0 (V)	1373h	04979	0 to V/f 8	1 Hz	
B113	Free-setting V/f voltage (7)	R/W	0.0 to 800.0 (V)	1374h	04980	0 to 8000	0.1 V	

Holding Registers, "B" Group Fine Tuning Functions							
Func. Code	Name	R/W	Description	Network Data			
				Register		Range	Res.
				hex	dec.		
—	(Reserved)	—	—	1375h to 137Ah	04981 to 04986	—	—
B120	Brake Control Enable	R/W	00 .Disable 01 .Enable	137Bh	04987	0, 1	—
B121	Brake Wait Time for Release	R/W	Sets time delay between arrival at release frequency and the brake release signal	137Ch	04977	0 to 500	0.01 sec.
B122	Brake Wait Time for Acceleration	R/W	Sets time delay from receipt of brake confirmation signal to start of motor acceleration	137Dh	04979	0 to 500	0.01 sec.
B123	Brake Wait Time for Stopping	R/W	Sets time delay from brake confirmation signal turns OFF to inverter deceleration to 0 H	137Eh	04990	0 to 500	0.01 sec.
B124	Brake Wait Time for Confirmation	R/W	Sets the wait time for confirmation after turn ON/OFF of brake release	137Fh	04991	0 to 500	0.01 sec.
B125	Brake Release Frequency Setting	R/W	Sets the frequency of the brake release output signal after delay set by B121	1380h	04992	0 to 40000	0.01 Hz
B126	Brake Release Current Setting	R/W	Sets the minimum inverter current level above which the brake release signal is permitted	1381h	04993	0 to 1800	0.1 %
B127	Braking frequency	R/W	0.00 to 99.99, 100.0 to 400.0 Hz	1382h	04994	0 to 40000	0.01 Hz
—	(Reserved)	—	—	1383h	04995	—	—
—	(Reserved)	—	—	1384h	04996	—	—
B130	Over-voltage LADSTOP enable	R/W	00 .Disable 01 .Enable during deceleration and constant speed 02 .Enable during acceleration	1385h	04997	0, 1, 2	—
B131	Over-voltage LADSTOP level	R/W	330 to 390 (V) for 200V class, 660 to 780 (V) for 400V class	1386h	04998	330 to 390 660 to 780	1 V
B132	Acceleration and deceleration rate at overvoltage suppression	R/W	0.10 to 30.00 (seconds)	1387h	04999	10 to 3000	0.01 sec.
B133	Overvoltage suppression proportional gain	R/W	0.00 to 2.55	1388h	05000	0 to 255	0.01
B134	Overvoltage suppression integral time	R/W	0.000 to 9.999, 10.00 to 63.53 (seconds)	1389h	05001		
—	(Reserved)	—	—	1390h to 1400h	05002 to 05120	—	—

Holding Registers, "C" Group Intelligent Terminal Functions								
Func. Code	Name	R/W	Description	Network Data				
				Register		Range	Res.	
				hex	dec.			
C001	Terminal [1] function	R/W	See "Input Terminal Configuration" on page 3-50	1401h	05121	1 to 9, 11 to 18, 20 to 24, 26 to 29, 31 to 48, no	—	
C002	Terminal [2] function	R/W		1402h	05122			
C003	Terminal [3] function	R/W		1403h	05123			
C004	Terminal [4] function	R/W		1404h	05124			
C005	Terminal [5] function	R/W		1405h	05125			
C006	Terminal [6] function	R/W		1406h	05126			
C007	Terminal [7] function	R/W		1407h	05127			
C008	Terminal [8] function	R/W		1408h	05128			
—	(Reserved)	—	—	1409h	05129	—	—	
—	(Reserved)	—	—	140Ah	05130	—	—	
C011	Terminal [1] active state	R/W	Select logic convention, two option codes: 00..Normally open (N.O.) 01..Normally closed (N.C.)	140Bh	05131	0, 1	—	
C012	Terminal [2] active state	R/W		140Ch	05132			
C013	Terminal [3] active state	R/W		140Dh	05133			
C014	Terminal [4] active state	R/W		140Eh	05134			
C015	Terminal [5] active state	R/W		140Fh	05135			
C016	Terminal [6] active state	R/W		1410h	05136			
C017	Terminal [7] active state	R/W		1411h	05137			
C018	Terminal [8] active state	R/W		1412h	05138			
C019	Terminal [FW] active state	R/W		1413h	05139			
—	(Reserved)	—	—	1414h	05140	—	—	
C021	Terminal [11] function	R/W	See "Output Terminal Configuration" on page 3-55	1415h	05141	0 to 13, 19 to 26	—	
C022	Terminal [12] function	R/W		1416h	05142			
C023	Terminal [13] function	R/W		1417h	05143			
C024	Terminal [14] function	R/W		1418h	05144			
C025	Terminal [15] function	R/W		1419h	05145			
C026	Alarm relay terminal function	R/W		141Ah	05146			
C027	[FM] signal selection	R/W	See "Output Terminal Configuration" on page 3-55	141Bh	05147	0 to 10, 12	—	
C028	[AM] signal selection	R/W		141Ch	05148			
C029	[AMI] signal selection	R/W		141Dh	05149			
C030	Digital current monitor reference value	R/W	Current with digital current monitor output at 1.44 kHz	141Eh	05150	200 to 2000	0.1 %	
C031	Terminal [11] active state	R/W	Select logic convention, two option codes: 00..Normally open (N.O.) 01..Normally closed (N.C.)	141Fh	05151	0, 1	—	
C032	Terminal [12] active state	R/W		1420h	05152			
C033	Terminal [13] active state	R/W		1421h	05153			
C034	Terminal [14] active state	R/W		1422h	05154			
C035	Terminal [15] active state	R/W		1423h	05155			
C036	Alarm relay active state	R/W		1424h	05156			

Holding Registers, "C" Group Intelligent Terminal Functions							
Func. Code	Name	R/W	Description	Network Data			
				Register		Range	Res.
				hex	dec.		
—	(Reserved)	—	—	1425h	05157	—	—
C038	—	R/W	00 . Output during accel/ decel and constant speed 01 . Output only during constant speed	1426h	05158	0, 1	—
C039	—	R/W	0.0 to 2.0 x rated inverter current	1427h	05159	0 to 1800	0.1 %
C040	—	R/W	00 .During accel / decel / constant speed 01 .During constant speed	1428h	05160	0, 1	—
C041	—	R/W	0.00 x rated current to 2.00 x rated current (A)	1429h	05161	0 to 1800	0.1 %
C042	H	R/W	Sets the frequency arrival setting threshold for the output frequency during acceleration	142Ah	05162	0 to 40000	0.01 Hz
C042	L	R/W		142Bh	05163		
C043	H	R/W	Sets the frequency arrival setting threshold for the output frequency during deceleration	142Ch	05164	0 to 40000	0.01 Hz
C043	L	R/W		142Dh	05165		
C044	—	R/W	Sets the PID loop error threshold SP - PV (absolute value) to trigger intelligent output [OD]	142Eh	05166	0 to 1000	0.1 %
C045	H	R/W	0.0 to 99.99, 100.0 to 400.0 (Hz)	142Fh	05167	0 to 40000	0.01 Hz
C045	L	R/W		1430h	05168		
C046	H	R/W	0.0 to 99.99, 100.0 to 400.0 (Hz)	1431h	05169	0 to 40000	0.01 Hz
C046	L	R/W		1432h	05170		
—	(Reserved)	—	—	1433h to 1437h	05171 to 05175	—	—
C052	—	R/W	0.0 to 100.0 (%)	1438h	05176	0 to 1000	0.1 %
C053	—	R/W	0.0 to 100.0 (%)	1439h	05177	0 to 1000	0.1 %
—	(Reserved)	—	—	143Ah	05178		
C055	—	R/W	Threshold for intelligent output terminal [OTQ], quadrant I	143Bh	05179	0 to 180	1 %
C056	—	R/W	Threshold for intelligent output terminal [OTQ], quadrant II	143Ch	05180	0 to 180	1 %
C057	—	R/W	Threshold for intelligent output terminal [OTQ], quadrant III	143Dh	05181	0 to 180	1 %
C058	—	R/W	Threshold for intelligent output terminal [OTQ], quadrant IV	143Eh	05182	0 to 180	1 %

Holding Registers, "C" Group Intelligent Terminal Functions								
Func. Code	Name	R/W	Description	Network Data				
				Register		Range	Res.	
				hex	dec.			
—	(Reserved)	—	—	143Fh	05183	—	—	
—	(Reserved)	—	—	1440h	05184	—	—	
C061	—	Electronic thermal warning level setting	R/W	Sets the threshold for intelligent output [THM]	1441h	05185	0 to 100	1 %
C062	—	Alarm code output	R/W	00..Disable 01..Enable – 3-bit code 02..Enable – 4-bit code	1442h	05186	0, 1, 2	—
C063	—	Zero speed detection level	R/W	0.00 to 99.99 / 100.0 (Hz)	1443h	05187	0 to 10000	0.01 Hz
C064	—	Heatsink overheat warning level	R/W	Alarm temperature threshold for heatsink in inverter	1444h	05188	0 to 200	1 °C
—	(Reserved)	—	—	1445h to 144Ah	05189 to 05194	—	—	
C071	—	Communication speed selection	R/W	02..Test 03..2400 (bps) 04..4800 (bps) 05..9600 (bps) 06..19200 (bps)	144Bh	05195	2 to 6	—
C072	—	Node allocation	R/W	Set the address of the inverter on the network	144Ch	05196	1 to 32	—
C073	—	Communication data length selection	R/W	07..7-bit data 08..8-bit data	144Dh	05197	7, 8	bits
C074	—	Communication parity selection	R/W	00..No parity 01..Even parity 02..Odd parity	144Eh	05198	0, 1, 2	—
C075	—	Communication stop bit selection	R/W	01..1 Stop bit 02..2 Stop bits	144Fh	05199	1, 2	bits
C076	—	Action upon communication error selection	R/W	00..Trip 01..Trip after deceleration and stop 02..No action (ignore errors) 03..Free-run stop 04..Decelerate and stop	1450h	05200	0 to 4	—
C077	—	Communication timeout before trip	R/W	0.00 to 99.99 (seconds)	1451h	05201	0 to 9999	0.01 sec.
C078	—	Communication wait time	R/W	Time the inverter waits after receiving a message before it transmits	1452h	05202	0 to 1000	1 msec.
C079	—	Communication protocol select	R/W	00..ASCII 01..ModBus RTU	1453h	05203	0, 1	—
—	(Reserved)	—	—	1454h	05204	—	—	
C081	—	[O] input span calibration	R/W	0. to 9999., 1000 to 6553 (10000 to 65530)	1455h	05205	0 to 65530	1
C082	—	[OI] input span calibration	R/W	0. to 9999., 1000 to 6553 (10000 to 65530)	1456h	05206	0 to 65530	1
C083	—	[O2] input span calibration	R/W	0. to 9999., 1000 to 6553 (10000 to 65530)	1457h	05207	0 to 65530	1
—	(Reserved)	—	—	1458h	05208	—	—	

Holding Registers, "C" Group Intelligent Terminal Functions								
Func. Code	Name	R/W	Description	Network Data				
				Register		Range	Res.	
				hex	dec.			
C085	—	Thermistor input tuning	R/W	0.0 to 999.9., 1000	1459h	05209		
—	—	(Reserved)	—	—	145Ah to 145Eh	05210 to 05214	—	—
C091	—	Debug mode enable	R	00 . No display 01 . Display	145Fh	05215	0, 1	—
—	—	(Reserved)	—	—	1460h to 1468h	05216 to 05224	—	—
C101	—	Up/Down memory mode selection	R/W	00 . Clear last freq. (return to default freq. F001) 01 . Keep last frequency adjusted by UP/DWN	1469h	05225	0, 1	—
C102	—	Reset mode selection	R/W	00 . Cancel trip state, stop inverter output, reset CPU; clear position counter at ON transition 01 . Cancel trip state, stop inverter output, reset CPU; clear position counter at OFF transition 02 . Cancel trip state and clear position counter; no effect if a trip does not exist 03 . Cancel trip state but does not clear position counter; no effect if a trip does not exist	146Ah	05226	0 to 3	—
C103	—	Restart mode after reset	R/W	00 . Restart at 0 Hz 01 . Resume operation after frequency matching 02 . Restart with active matching frequency	146Bh	05227		
—	—	(Reserved)	—	—	146Ch	05228	—	—
C105	—	FM gain adjustment	R/W	50. to 200. (%)	146Dh	05229	50 to 200	1 %
C106	—	AM gain adjustment	R/W	50. to 200. (%)	146Eh	05230	50 to 200	1 %
C107	—	AMI gain adjustment	R/W	50. to 200. (%)	146Fh	05231	50 to 200	1 %
—	—	(Reserved)	—	—	1470h	05232	—	—
C109	—	AM bias adjustment	R/W	0. to 100. (%)	1471h	05233	0 to 100	1 %
C110	—	AMI bias adjustment	R/W	0. to 100. (%)	1472h	05234	0 to 100	1 %
C111	—	Overload setting (2)	R/W	0.0 x rated current to 2.00 x rated current (A)	1473h	05235	0 to 1800	0.1 %
—	—	(Reserved)	—	—	1474h to 147Ch	05236 to 05244	—	—
C121	—	[O] input zero calibration	R/W	0. to 9999., 1000 to 6553 (10000 to 65530)	147Dh	05245	0 to 65530	1
C122	—	[OI] input zero calibration	R/W	0. to 9999., 1000 to 6553 (10000 to 65530)	147Eh	05246	0 to 65530	1

Holding Registers, "C" Group Intelligent Terminal Functions								
Func. Code	Name	R/W	Description	Network Data				
				Register		Range	Res.	
				hex	dec.			
C123	[O2] input zero calibration	R/W	0. to 9999., 1000 to 6553 (10000 to 65530)	147Fh	05247	0 to 65530	1	
—	(Reserved)	—	—	1480h to 1485h	05248 to 05253	—	—	
C130	Term. [11] ON-delay time	R/W	0.0 to 100.0 (seconds)	1486h	05254	0 to 1000	0.1 sec.	
C131	Term. [11] OFF-delay time	R/W	0.0 to 100.0 (seconds)	1487h	05255	0 to 1000	0.1 sec.	
C132	Term. [12] ON-delay time	R/W	0.0 to 100.0 (seconds)	1488h	05256	0 to 1000	0.1 sec.	
C133	Term. [12] OFF-delay time	R/W	0.0 to 100.0 (seconds)	1489h	05257	0 to 1000	0.1 sec.	
C134	Term. [13] ON-delay time	R/W	0.0 to 100.0 (seconds)	148Ah	05258	0 to 1000	0.1 sec.	
C135	Term. [13] OFF-delay time	R/W	0.0 to 100.0 (seconds)	148Bh	05259	0 to 1000	0.1 sec.	
C136	Term. [14] ON-delay time	R/W	0.0 to 100.0 (seconds)	148Ch	05260	0 to 1000	0.1 sec.	
C137	Term. [14] OFF-delay time	R/W	0.0 to 100.0 (seconds)	148Dh	05261	0 to 1000	0.1 sec.	
C138	Term. [15] ON-delay time	R/W	0.0 to 100.0 (seconds)	148Eh	05262	0 to 1000	0.1 sec.	
C139	Term. [15] OFF-delay time	R/W	0.0 to 100.0 (seconds)	148Fh	05263	0 to 1000	0.1 sec.	
C140	Relay output ON-delay time	R/W	0.0 to 100.0 (seconds)	1490h	05264	0 to 1000	0.1 sec.	
C141	Relay output OFF-delay time	R/W	0.0 to 100.0 (seconds)	1491h	05265	0 to 1000	0.1 sec.	
C142	Logic output 1 function A	R/W	All programmable output functions available (except LOG1 to LOG6)	1492h	05266	—	—	
C143	Logic output 1 function B	R/W		1493h	05267			
C144	Logic output 1 operator	R/W	00..AND 01..OR 02..XOR (exclusive OR)	1494h	05268	0, 1, 2	—	
C145	Logic output 2 function A	R/W	All programmable output functions available (except LOG1 to LOG6)	1495h	05269	—	—	
C146	Logic output 2 function B	R/W		1496h	05270			
C147	Logic output 2 operator	R/W	00..AND 01..OR 02..XOR (exclusive OR)	1497h	05271	0, 1, 2	—	
C148	Logic output 3 function A	R/W	All programmable output functions available (except LOG1 to LOG6)	1498h	05272	—	—	
C149	Logic output 3 function B	R/W		1499h	05273			
C150	Logic output 3 operator	R/W	00..AND 01..OR 02..XOR (exclusive OR)	149Ah	05274	0, 1, 2	—	
C151	Logic output 4 function A	R/W	All programmable output functions available (except LOG1 to LOG6)	149Bh	05275	—	—	
C152	Logic output 4 function B	R/W		149Ch	05276			
C153	Logic output 4 operator	R/W	00..AND 01..OR 02..XOR (exclusive OR)	149Dh	05277	0, 1, 2	—	
C154	Logic output 5 function A	R/W	All programmable output functions available (except LOG1 to LOG6)	149Eh	05278	—	—	
C155	Logic output 5 function B	R/W		149Fh	05279			

Holding Registers, "C" Group Intelligent Terminal Functions								
Func. Code	Name	R/W	Description	Network Data				
				Register		Range	Res.	
				hex	dec.			
C156	—	Logic output 5 operator	R/W	00 . AND 01 . OR 02 . XOR (exclusive OR)	14A0h	05280	0, 1, 2	—
C157	—	Logic output 6 function A	R/W	All programmable output functions available (except LOG1 to LOG6)	14A1h	05281	—	—
C158	—	Logic output 6 function B	R/W		14A2h	05282		
C159	—	Logic output 6 operator	R/W	00 . AND 01 . OR 02 . XOR (exclusive OR)	14A3h	05283	0, 1, 2	—
C160	—	Terminal [1] input response time setting	R/W	0. to 200. (x 2 milliseconds)	14A4h	05284	0 to 200	2 ms
C161	—	Terminal [2] input response time setting	R/W	0. to 200. (x 2 milliseconds)	14A5h	05285	0 to 200	2 ms
C162	—	Terminal [3] input response time setting	R/W	0. to 200. (x 2 milliseconds)	14A6h	05286	0 to 200	2 ms
C163	—	Terminal [4] input response time setting	R/W	0. to 200. (x 2 milliseconds)	14A7h	05287	0 to 200	2 ms
C164	—	Terminal [5] input response time setting	R/W	0. to 200. (x 2 milliseconds)	14A8h	05288	0 to 200	2 ms
C165	—	Terminal [6] input response time setting	R/W	0. to 200. (x 2 milliseconds)	14A9h	05289	0 to 200	2 ms
C166	—	Terminal [7] input response time setting	R/W	0. to 200. (x 2 milliseconds)	14AAh	05290	0 to 200	2 ms
C167	—	Terminal [8] input response time setting	R/W	0. to 200. (x 2 milliseconds)	14ABh	05291	0 to 200	2 ms
C168	—	Terminal [FW] input response time setting	R/W	0. to 200. (x 2 milliseconds)	14ACh	05292	0 to 200	2 ms
C169	—	Multi-speed position determination time	R/W	0. to 200. (x 2 milliseconds)	14ADh	05293	0 to 200	2 ms
—	—	(Reserved)	—	—	14AEh to 1500h	05294 to 05376	—	—

Holding Registers, "H" Group Motor Constants Functions								
Func. Code	Name	R/W	Description	Network Data				
				Register		Range	Res.	
				hex	dec.			
H001	—	Auto-tuning setting	R/W	00..Auto-tuning OFF 01..Auto-tune 02..Auto-tune (rotate motor)	1501h	05377	0, 1, 2	—
H002	—	Motor data selection, 1st motor	R/W	00..Standard motor data 01..Auto-tuning data 02..Adaptive tuning data	1502h	05378	0, 1, 2	—
H202	—	Motor data selection, 2nd motor	R/W	00..Standard motor data 01..Auto-tuning data 02..Adaptive tuning data	2502h	9474	0, 1, 2	—
H003	—	Motor capacity, 1st motor	R/W	0.20 to 75.00 (kW)	153h	05379	00 to 36 (see next table)	—
H203	—	Motor capacity, 2nd setting	R/W	0.20 to 75.00 (kW)	2503h	9475		—
H004	—	Motor poles setting, 1st motor	R/W	00..2 poles 01..4 poles 02..6 poles 03..8 poles 04..10 poles	1504h	05380	0 to 4	—
H204	—	Motor poles setting, 2nd motor	R/W	00..2 poles 01..4 poles 02..6 poles 03..8 poles 04..10 poles	2504h	9476	0 to 4	—
H005	H	Motor speed constant, 1st motor	R/W	Motor proportional gain constant, factory set	1505h	05381	0 to 80000	0.001
H005	L		R/W		1506h	05382		
H205	H	Motor speed constant, 2nd motor	R/W	Motor proportional gain constant, factory set	2505h	9477	0 to 80000	0.001
H205	L		R/W		2506h	9478		
H006	—	Motor stabilization constant	R/W	0. to 255. (factory set)	1507h	05383	0 to 255	1
—		(Reserved)	—	—	1508h to 1514h	05384 to 05396	—	—
H206	—	Motor stabilization constant, 2nd motor	R/W	0. to 255. (factory set)	2507h	09479	0 to 255	1
—		(Reserved)	—	—	2508h to 2514h	09480 to 09292	—	—
H306	—	Motor stabilization constant, 3rd motor	R/W	0. to 255. (factory set)	3507h	13575	0 to 255	1
—		(Reserved)	—	—	3508h to end	13576 to end	—	—
H020	H	Motor constant R1, 1st motor	R/W	0.001 to 9.999, 10.00 to 65.53 (Ohms)	1515h	05397	1 to 65530	0.001 Ω
H020	L		R/W		1516h	05398		
H220	H	Motor constant R1, 2nd motor	R/W	0.001 to 9.999, 10.00 to 65.53 (Ohms)	2515h	09293	1 to 65530	0.001 Ω
H220	L		R/W		2516h	09294		
H021	H	Motor constant R2, 1st motor	R/W	0.001 to 9.999, 10.00 to 65.53 (Ohms)	1517h	05399	1 to 65530	0.001 Ω
H021	L		R/W		1518h	05400		

Holding Registers, "H" Group Motor Constants Functions								
Func. Code		Name	R/W	Description	Network Data			
					Register		Range	Res.
					hex	dec.		
H221	H	Motor constant R2, 2nd motor	R/W	0.001 to 9.999, 10.00 to 65.53 (Ohms)	2517h	09495	1 to 65530	0.001 Ω
H221	L		R/W		2518h	09496		
H022	H	Motor constant L, 1st motor	R/W	0.01 to 99.99, 100.0 - 655.3 (mH)	1519h	05401	1 to 65530	0.01 mH
H022	L		R/W		151Ah	05402		
H222	H	Motor constant L, 2nd motor	R/W	0.01 to 99.99, 100.0 - 655.3 (mH)	2519h	09497	1 to 65530	0.01 mH
H222	L		R/W		251Ah	09498		
H023	H	Motor constant Io	R/W	0.01 to 99.99, 100.0 - 655.3 (A)	151Bh	05403	1 to 65530	0.01 A
H023	L		R/W		151Ch	05404		
H223	H	Motor constant Io, 2nd motor	R/W	0.01 to 99.99, 100.0 - 655.3 (A)	251Bh	09499	1 to 65530	0.01 A
H223	L		R/W		251Ch	09500		
H024	H	Motor Constant J	R/W	0.001 to 9.999, 10.00 to 99.99, 100.0 to 999.9, 1000 to 9999.	151Dh	05405	1 to 9999000	—
H024	L		R/W		151Eh	05406		
—		(Reserved)	—	—	151Fh to 1523h	05407 to 05411	—	—
H224	H	Motor constant J, 2nd motor	R/W	0.001 to 9.999, 10.00 to 99.99, 100.0 to 999.9, 1000 to 9999.	251Dh	09501	1 to 9999000	—
H224	L		R/W		251Eh	09502		
—		(Reserved)	—	—	221Fh to 2523h	09503 to 09507	—	—
H030	H	Auto constant R1, 1st motor	R/W	0.001 to 9.999, 10.00 to 65.53 (Ohms)	1524h	05412	1 to 65530	0.001 Ω
H030	L		R/W		1525h	05413		
H230	H	Auto constant R1, 2nd motor	R/W	0.001 to 9.999, 10.00 to 65.53 (Ohms)	2524h	09508	1 to 65530	0.001 Ω
H230	L		R/W		2525h	09509		
H031	H	Auto constant R2, 1st motor	R/W	0.001 to 9.999, 10.00 to 65.53 (Ohms)	1526h	05414	1 to 65530	0.001 Ω
H031	L		R/W		1527h	05415		
H231	H	Auto constant R2, 2nd motor	R/W	0.001 to 9.999, 10.00 to 65.53 (Ohms)	2526h	09510	1 to 65530	0.001 Ω
H231	L		R/W		2527h	09511		
H032	H	Auto constant L, 1st motor	R/W	0.01 to 99.99, 100.0 to 655.3 (mH)	1528h	05416	1 to 65530	0.01 mH
H032	L		R/W		1529h	05417		
H232	H	Auto constant L, 2nd motor	R/W	0.01 to 99.99, 100.0 to 655.3 (mH)	2528h	09512	1 to 65530	0.01 mH
H232	L		R/W		2529h	09513		
H033	H	Auto constant Io, 1st motor	R/W	0.01 to 99.99, 100.0 to 655.3 (mH)	152Ah	05418	1 to 65530	0.01 mH
H033	L		R/W		152Bh	05419		
H233	H	Auto constant Io, 2nd motor	R/W	0.01 to 99.99, 100.0 to 655.3 (mH)	252Ah	09514	1 to 65530	0.01 mH
H233	L		R/W		252Bh	09515		

Holding Registers, "H" Group Motor Constants Functions								
Func. Code		Name	R/W	Description	Network Data			
					Register		Range	Res.
					hex	dec.		
H034	H	Auto constant J, 1st motor	R/W	0.001 to 9.999, 10.00 to 99.99, 100.0 to 999.9, 1000 to 9999.	152Ch	05420	1 to 9999000	0.001
H034	L		R/W		152Dh	05421		
H234	H	Auto constant J, 1st motor	R/W	0.001 to 9.999, 10.00 to 99.99, 100.0 to 999.9, 1000 to 9999.	252Ch	09516	1 to 9999000	0.001
H234	L		R/W		252Dh	09517		
—		(Reserved)	—	—	152Eh to 153Ch	05422 to 05436	—	—
H050	—	PI proportional gain for 1st motor	R/W	0.0 to 999.9, 1000.	153Dh	05437	0 to 10000	0.1 %
H250	—	PI proportional gain for 2nd motor	R/W	0.0 to 999.9, 1000.	253Dh	09533	0 to 10000	0.1 %
H051	—	PI integral gain for 1st motor	R/W	0.0 to 999.9, 1000.	153Eh	05438	0 to 10000	0.1 %
H251	—	PI integral gain for 2nd motor	R/W	0.0 to 999.9, 1000.	253Eh	09534	0 to 10000	0.1 %
H052	—	P proportional gain setting for 1st motor	R/W	0.01 to 10.00	153Fh	05439	0 to 1000	0.01
—		(Reserved)	—	—	1540h to 1546h	05440 to 05446	—	—
H252	—	P proportional gain setting for 2nd motor	R/W	0.01 to 10.00	253Fh	09535	0 to 1000	0.01
—		(Reserved)	—	—	2540h to 2546h	09536 to 09542	—	—
H060	—	Zero LV limit for 1st motor	R/W	0.0 to 100.0	1547h	05447	0 to 1000	0.1 %
H260	—	Zero LV limit for 2nd motor	R/W	0.0 to 100.0	2547h	09543	0 to 1000	0.1 %
H061	—	Zero LV starting boost current for 1st motor	R/W	0. to 50. (%)	1548h	05448	0 to 50	1 %
—		(Reserved)	—	—	1549h to 1550h	05449 to 05456	—	—
H261	—	Zero LV starting boost current for 2nd motor	R/W	0. to 50. (%)	2548h	09544	0 to 50	1 %
—		(Reserved)	—	—	2549h to 3102h	09545 to 12546	—	—
H070	—	Terminal selection PI proportional gain setting	R/W	0.0 to 999.9, 1000	1551h	05457	0 to 10000	0.1 %
H071	—	Terminal selection PI integral gain setting	R/W	0.0 to 999.9, 1000	1552h	05458	0 to 10000	0.1 %
H072	—	Terminal selection P proportional gain setting	R/W	0.00 to 10.00	1553h	05459	0 to 1000	0.01

Holding Registers, "H" Group Motor Constants Functions								
Func. Code	Name	R/W	Description	Network Data				
				Register		Range	Res.	
				hex	dec.			
H073	Gain switching time	R/W	0. to 999. (milliseconds)	1554h	05460	0 to 9999	1 msec.	
—	(Reserved)	—	—	1555h to 1600h	05461 to 05632	—	—	

Use the codes in the table below to return parameters for H003 and H203 (motor capacity selection).

Code Data	00	01	02	03	04	05	06	07	08	09	10
Japan or U.S.A. mode (B085 = 00 or 02)	0.2 kW	—	0.4	—	0.75	—	1.5	2.2	—	3.7	—
EU mode (B085=01)	0.2 kW	0.37	—	0.55	0.75	1.1	1.5	2.2	3.0	—	4.0
Code Data	11	12	13	14	15	16	17	18	19	20	21
Japan or U.S.A. mode (B085 = 00 or 02)	5.5 kW	7.5	11	15	18.5	22	30	37	45	55	75
EU mode (B085=01)	5.5 kW	7.5	11	15	18.5	22	30	37	45	55	75
Code Data	22	23	24	25	26	27	28	29	30	31	32
Japan or U.S.A. mode (B085 = 00 or 02)	90 kW	110	132	150	160	185	200	220	250	280	300
EU mode (B085=01)	90 kW	110	132	150	160	185	300	220	250	280	300
Code Data	33	34	35	36							
Japan or U.S.A. mode (B085 = 00 or 02)	315 kW	340	355	400							
EU mode (B085=01)	315 kW	340	355	400							

Holding Registers, "P" Group Expansion Card Functions								
Func. Code	Name	R/W	Description	Network Data				
				Register		Range	Res.	
				hex	dec.			
P001	—	Operation mode on expansion card 1 error	R/W	00..Trip (stop motor) 01..Continuous operation	1601h	05633	0, 1	—
P002	—	Operation mode on expansion card 2 error	R/W	00..Trip (stop motor) 01..Continuous operation	1602h	05634	0, 1	—
—	—	(Reserved)	—	—	1603h to 160Ah	05635 to 05642	—	—
P011	—	Encoder pulse-per-revolution (PPR) setting	R/W	128 to 65000 (pulses per revolution)	160Bh	05643	128 to 65000	1
P012	—	Control pulse setting	R/W	00..Automatic Speed Regulation (ASR) mode 01..Automatic Position Regulation (APR) mode 02..Absolute Position Control 03..High-resolution Absolute Position Control	160Ch	05644	0, 1	—
P013	—	Pulse line mode setting	R/W	00..Quadrature mode 01..Count and direction 02..Separate forward and reverse pulse trains	160Dh	05645	0, 1, 2	—
P014	—	Home search stop position setting	R/W	0. to 4095. (pulses)	160Eh	05646	0 to 4095	1 pulse
P015	—	Home search speed setting	R/W	Start frequency to maximum frequency (up to 120.0) (Hz)	160Fh	05647	0 to 12000	0.01 Hz
P016	—	Home search direction setting	R/W	00..Forward 01..Reverse	1610h	05648	0, 1	—
P017	—	Home search completion range setting	R/W	0. to 9999., 1000 (10,000) (pulses)	1611h	05649	0 to 10000	1
P018	—	Home search completion delay time setting	R/W	0.00 to 9.99 (seconds)	1612h	05650	0 to 999	0.01 sec.
P019	—	Electronic gear set position selection	R/W	00..Position feedback side 01..Position command side	1613h	05651	0, 1	—
P020	—	Electronic gear ratio numerator setting	R/W	0. to 9999.	1614h	05652	1 to 9999	—
P021	—	Electronic gear ratio denominator setting	R/W	1 to 9999	1615h	05653	1 to 9999	—
P022	—	Feed-forward gain setting	R/W	0.00 to 99.99, 100.0 to 655.3	1616h	05654	0 to 65535	0.01
P023	—	Position loop gain setting	R/W	0.00 to 99.99, 100.0	1617h	05655	0 to 10000	0.01
P024	—	Position bias setting	R/W	-204 (-2048) / -999. to 2048	1618h	05656	-2048 to 2048	1
P025	—	Temperature compensation thermistor enable	R/W	00..No compensation 01..With compensation	1619h	05657	0, 1	—
P026	—	Over-speed error detection level setting	R/W	0.0 to 150.0 (%)	161Ah	05658	0 to 1500	0.1 %
P027	—	Speed deviation error detection level setting	R/W	0.00 to 99.99, 100.0 to 120.0 (Hz)	161Bh	05659	0 to 12000	0.01 Hz

Holding Registers, "P" Group Expansion Card Functions									
Func. Code	Name	R/W	Description	Network Data					
				Register		Range	Res.		
				hex	dec.				
P028	—		Numerator of motor gear ratio	R/W	0. to 9999.	161Ch	05660	1 to 9999	1
P029	—		Denominator of motor gear ratio	R/W	1 to 9999	161Dh	05661	1 to 9999	1
—			(Reserved)	—	—	161Eh	05662	—	—
P031	—		Accel/decel time input selection	R/W	00 . Inverter 01 . Expansion card 1 02 . Expansion card 2	161Fh	05663	0, 1, 2	—
P032	—		Positioning command input selection	R/W	00 . Inverter 01 . Expansion card 1 02 . Expansion card 2	1620h	05664	0, 1, 2	—
P033	—		Torque command input selection	R/W	00 . [O] terminal 01 . [OI] terminal 02 . [O2] terminal 03 . Inverter keypad (P034)	1621h	05665	0 to 3	—
P034	—		Torque command setting	R/W	0. to 200. (%)	1622h	05666	0 to 180	1 %
P035	—		Torque command polarity selection	R/W	00 . Indicated by signal polarity 01 . Depends on motor direction	1623h	05667	0, 1	—
P036	—		Torque bias mode	R/W	00 . Disable 01 . Inverter keypad (P037) 02 . [O2] terminal input	1624h	05668	0, 1, 2	—
P037	—		Torque bias value	R/W	-200. to 200. (%)	1625h	05669	0 to 180	1
P038	—		Torque bias polarity selection	R/W	00 . Indicated by polarity 01 . Depends on motor direction	1626h	05670	0, 1	—
P039	H		Forward maximum speed for torque-controlled operation	R/W	0.00 to Maximum frequency (Hz)	1627h	05671	0 to max. frequency (up to 40000)	0.01 Hz
P039	L			R/W		1628h	05672		
P040	H		Reverse maximum speed for torque-controlled operation	R/W	0.00 to Maximum frequency (Hz)	1629h	05673	0 to max. frequency (up to 40000)	0.01 Hz
P040	L			R/W		162Ah	05674		
—			(Reserved)	—	—	162Bh	05675	—	—
—			(Reserved)	—	—	162Ch	05676	—	—
—			(Reserved)	—	—	162Dh	05677	—	—
P044	—		DeviceNet comm watchdog timer	R/W	0.00 to 99.99 (seconds)	162Eh	05678	0 to 9999	0.01 sec.
P045	—		Inverter action on DeviceNet comm error	R/W	00 . Trip 01 . Decelerate and trip 02 . Hold last speed 03 . Free run stop 04 . Decelerate and stop	162Fh	05679	0 to 4	—
P046	—		DeviceNet polled I/O: Output instance number	R/W	20, 21, 100	1630h	05680	20, 21, 100	—

Holding Registers, "P" Group Expansion Card Functions								
Func. Code	Name	R/W	Description	Network Data				
				Register		Range	Res.	
				hex	dec.			
P047	—	DeviceNet polled I/O: Input instance number	R/W	70, 71, 101	1631h	05681	70, 71, 101	—
P048	—	Inverter action on DeviceNet idle mode	R/W	00..Trip 01..Decelerate and trip 02..Hold last speed 03..Free run stop 04..Decelerate and stop	1632h	05682	0 to 4	—
P049	—	Motor poles setting for RPM	R/W	00 to 38 (even numbers only)	1633h	05683	0 to 19	1 = 2 poles
—	—	(Reserved)	—	—	1634h to 1638h	05684 to 05688	—	—
P055	—	Pulse train frequency span	R/W	1.0 to 50.0 (kHz)	1639h	05689	10 to 500	0.1 kHz
P056	—	Pulse train frequency time constant	R/W	0.01 to 2.00 (seconds)	163Ah	05690	1 to 200	0.01 sec.
P057	—	Pulse train frequency bias	R/W	-100. to 100. (%)	163Bh	05691	-100 to 100	1 %
P058	—	Pulse train frequency limit	R/W	0. to 100. (%)	163Ch	05692	0 to 100	1 %
—	—	(Reserved)	—	—	163Dh	05693	—	—
P060	H	Multi-stage position setting 0	R/W	Reverse side to forward side (upper four digits including sign “_”)	163Eh	05694	—	—
P060	L		R/W		163Fh	05695		
P061	H	Multi-stage position setting 1	R/W	Reverse side to forward side (upper four digits including sign “_”)	1640h	05696	—	—
P061	L		R/W		1641h	05697		
P062	H	Multi-stage position setting 2	R/W	Reverse side to forward side (upper four digits including sign “_”)	1642h	05698	—	—
P062	L		R/W		1643h	05699		
P063	H	Multi-stage position setting 3	R/W	Reverse side to forward side (upper four digits including sign “_”)	1644h	05700	—	—
P063	L		R/W		1645h	05701		
P064	H	Multi-stage position setting 4	R/W	Reverse side to forward side (upper four digits including sign “_”)	1646h	05702	—	—
P064	L		R/W		1647h	05703		
P065	H	Multi-stage position setting 5	R/W	Reverse side to forward side (upper four digits including sign “_”)	1648h	05704	—	—
P065	L		R/W		1649h	05705		
P066	H	Multi-stage position setting 6	R/W	Reverse side to forward side (upper four digits including sign “_”)	164Ah	05706	—	—
P066	L		R/W		164Bh	05707		
P067	H	Multi-stage position setting 7	R/W	Reverse side to forward side (upper four digits including sign “_”)	164Ch	05708	—	—
P067	L		R/W		164Dh	05709		
P068	—	Home position mode selection	R/W	00..Low 01..High 02..High 2	164Eh	05710	0, 1, 2	—
P069	—	Home position direction selection	R/W	00..Forward 01..Reverse	164Fh	05711	0, 1	—

Holding Registers, "P" Group Expansion Card Functions									
Func. Code	Name	R/W	Description	Network Data					
				Register		Range	Res.		
				hex	dec.				
P070	—		Low speed homing frequency	R/W	0.00 to 10.00 (Hz)	1650h	05712	0 to 1000	0.01 Hz
P071	—		High speed homing frequency	R/W	0.00 to 99.99 / 100.0 to maximum frequency setting, 1st motor (Hz)	1651h	05713	0 to 40000	0.01 Hz
P072	H		Forward position range setting	R/W	0 to 536870912 (when P012 = 02), 0 to 2147483647 (when P013 = 03) (upper four digits)	1652h	05714	See description	1
P072	L	R/W		1653h		05715			
P073	H		Reverse position range	R/W	0 to 536870912 (when P012 = 02), 0 to 2147483647 (when P013 = 03) (upper four digits)	1654h	05716	See description	1
P073	L	R/W		1655h		05717			
—			(Reserved)	—	—	1656h to 1665h	05718 to 05733	—	—
P100	—		Easy sequence parameter (U00)	R/W	0. to 9999., 1000 to 6553 (10000 to 65535)	1666h	05734	0 to 65530	1
P101	—		Easy sequence parameter (U01)	R/W	0. to 9999., 1000 to 6553 (10000 to 65535)	1667h	05735	0 to 65530	1
P102	—		Easy sequence parameter (U02)	R/W	0. to 9999., 1000 to 6553 (10000 to 65535)	1668h	05736	0 to 65530	1
P103	—		Easy sequence parameter (U03)	R/W	0. to 9999., 1000 to 6553 (10000 to 65535)	1669h	05737	0 to 65530	1
P104	—		Easy sequence parameter (U04)	R/W	0. to 9999., 1000 to 6553 (10000 to 65535)	166Ah	05738	0 to 65530	1
P105	—		Easy sequence parameter (U05)	R/W	0. to 9999., 1000 to 6553 (10000 to 65535)	166Bh	05739	0 to 65530	1
P106	—		Easy sequence parameter (U06)	R/W	0. to 9999., 1000 to 6553 (10000 to 65535)	166Ch	05740	0 to 65530	1
P107	—		Easy sequence parameter (U07)	R/W	0. to 9999., 1000 to 6553 (10000 to 65535)	166Dh	05741	0 to 65530	1
P108	—		Easy sequence parameter (U08)	R/W	0. to 9999., 1000 to 6553 (10000 to 65535)	166Eh	05742	0 to 65530	1
P109	—		Easy sequence parameter (U09)	R/W	0. to 9999., 1000 to 6553 (10000 to 65535)	166Fh	05743	0 to 65530	1
P110	—		Easy sequence parameter (U10)	R/W	0. to 9999., 1000 to 6553 (10000 to 65535)	1670h	05744	0 to 65530	1
P111	—		Easy sequence parameter (U11)	R/W	0. to 9999., 1000 to 6553 (10000 to 65535)	1671h	05745	0 to 65530	1
P112	—		Easy sequence parameter (U12)	R/W	0. to 9999., 1000 to 6553 (10000 to 65535)	1672h	05746	0 to 65530	1
P113	—		Easy sequence parameter (U13)	R/W	0. to 9999., 1000 to 6553 (10000 to 65535)	1673h	05747	0 to 65530	1
P114	—		Easy sequence parameter (U14)	R/W	0. to 9999., 1000 to 6553 (10000 to 65535)	1674h	05748	0 to 65530	1
P115	—		Easy sequence parameter (U15)	R/W	0. to 9999., 1000 to 6553 (10000 to 65535)	1675h	05749	0 to 65530	1

Holding Registers, "P" Group Expansion Card Functions								
Func. Code	Name	R/W	Description	Network Data				
				Register		Range	Res.	
				hex	dec.			
P116	— Easy sequence parameter (U16)	R/W	0. to 9999., 1000 to 6553 (10000 to 65535)	1676h	05750	0 to 65530	1	
P117	— Easy sequence parameter (U17)	R/W	0. to 9999., 1000 to 6553 (10000 to 65535)	1677h	05751	0 to 65530	1	
P118	— Easy sequence parameter (U18)	R/W	0. to 9999., 1000 to 6553 (10000 to 65535)	1678h	05752	0 to 65530	1	
P119	— Easy sequence parameter (U19)	R/W	0. to 9999., 1000 to 6553 (10000 to 65535)	1679h	05753	0 to 65530	1	
P120	— Easy sequence parameter (U20)	R/W	0. to 9999., 1000 to 6553 (10000 to 65535)	167Ah	05754	0 to 65530	1	
P121	— Easy sequence parameter (U21)	R/W	0. to 9999., 1000 to 6553 (10000 to 65535)	167Bh	05755	0 to 65530	1	
P122	— Easy sequence parameter (U22)	R/W	0. to 9999., 1000 to 6553 (10000 to 65535)	167Ch	05756	0 to 65530	1	
P123	— Easy sequence parameter (U23)	R/W	0. to 9999., 1000 to 6553 (10000 to 65535)	167Dh	05757	0 to 65530	1	
P124	— Easy sequence parameter (U24)	R/W	0. to 9999., 1000 to 6553 (10000 to 65535)	167Eh	05758	0 to 65530	1	
P125	— Easy sequence parameter (U25)	R/W	0. to 9999., 1000 to 6553 (10000 to 65535)	167Fh	05759	0 to 65530	1	
P126	— Easy sequence parameter (U26)	R/W	0. to 9999., 1000 to 6553 (10000 to 65535)	1680h	05760	0 to 65530	1	
P127	— Easy sequence parameter (U27)	R/W	0. to 9999., 1000 to 6553 (10000 to 65535)	1681h	05761	0 to 65530	1	
P128	— Easy sequence parameter (U28)	R/W	0. to 9999., 1000 to 6553 (10000 to 65535)	1682h	05762	0 to 65530	1	
P129	— Easy sequence parameter (U29)	R/W	0. to 9999., 1000 to 6553 (10000 to 65535)	1683h	05763	0 to 65530	1	
P130	— Easy sequence parameter (U30)	R/W	0. to 9999., 1000 to 6553 (10000 to 65535)	1684h	05764	0 to 65530	1	
P131	— Easy sequence parameter (U31)	R/W	0. to 9999., 1000 to 6553 (10000 to 65535)	1685h	05765	0 to 65530	1	
—	(Reserved)	—	—	1686h to 2102h	05766 to 08450	—	—	

Drive Parameter Settings Tables

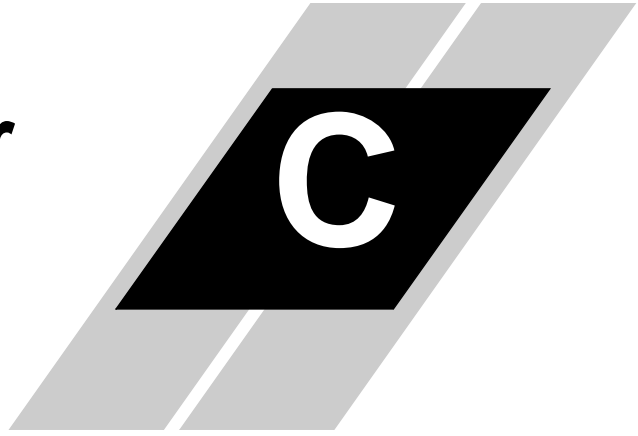

In This Appendix....	page
— Introduction	2
— Parameter Settings for Keypad Entry	2

Introduction

This appendix lists the user-programmable parameters for the SJ7002 series inverters and the default values for European, U.S. and Japanese product types. The right-most column of the tables is blank so you can record values you have changed from the default. This involves just a few parameters for most applications.

Parameter Settings for Keypad Entry

SJ7002 series inverters provide many functions and parameters that can be configured by the user. We recommend that you record all parameters that have been edited, in order to help in troubleshooting or recovery from a loss of parameter data.

Inverter model SJ700

MFG. No.

} This information is printed on the specification label located on the right side of the inverter.

Main Profile Parameters

“F” Group Parameters		Default Setting			User Setting
Func. Code	Name	FEF2, FE2 (Europe)	FU2, FU2 (U.S.A.)	FF2, F2 (Japan)	
F001	Output frequency setting	0.00	0.00	0.00	
F002	Acceleration (1) time setting	30.0	30.0	30.0	
F202	Acceleration (1) time setting, 2nd motor	30.0	30.0	30.0	
F302	Acceleration (1) time setting, 3rd motor	30.0	30.0	30.0	
F003	Deceleration (1) time setting	30.0	30.0	30.0	
F203	Deceleration (1) time setting, 2nd motor	30.0	30.0	30.0	
F303	Deceleration (1) time setting, 3rd motor	30.0	30.0	30.0	
F004	Keypad Run key routing	00	00	00	

Standard Functions

“A” Group Parameters		Default Setting			User Setting
Func. Code	Name	FEF2, FE2 (Europe)	FU2, FU2 (U.S.A.)	FF2, F2 (Japan)	
A001	Frequency source setting	01	01	02	
A002	Run command source setting	01	01	02	
A003	Base frequency setting	50.	60.	60.	
A203	Base frequency setting, 2nd motor	50.	60.	60.	
A303	Base frequency setting, 3rd motor	50.	60.	60.	
A004	Maximum frequency setting	50.	60.	60.	
A204	Maximum frequency setting, 2nd motor	50.	60.	60.	
A304	Maximum frequency setting, 3rd motor	50.	60.	60.	
A005	[AT] selection	00	00	00	
A006	[O2] selection	03	03	03	
A011	[O]-[L] input active range start frequency	0.00	0.00	0.00	
A012	[O]-[L] input active range end frequency	0.00	0.00	0.00	
A013	[O]-[L] input active range start voltage	0.	0.	0.	
A014	[O]-[L] input active range end voltage	100.	100.	100.	
A015	[O]-[L] input start frequency enable	01	01	01	
A016	External frequency filter time const.	8.	8.	8.	
A017	Easy sequence function enable	00	00	00	
A019	Multi-speed operation selection	00	00	00	
A020	Multi-speed frequency setting	0.00	0.00	0.00	
A220	Multi-speed frequency setting, 2nd motor	0.00	0.00	0.00	
A320	Multi-speed frequency setting, 3rd motor	0.00	0.00	0.00	
A021	Multi-speed 1 setting	0.00	0.00	0.00	
A022	Multi-speed 2 setting	0.00	0.00	0.00	
A023	Multi-speed 3 setting	0.00	0.00	0.00	
A024	Multi-speed 4 setting	0.00	0.00	0.00	
A025	Multi-speed 5 setting	0.00	0.00	0.00	
A026	Multi-speed 6 setting	0.00	0.00	0.00	
A027	Multi-speed 7 setting	0.00	0.00	0.00	
A028	Multi-speed 8 setting	0.00	0.00	0.00	
A029	Multi-speed 9 setting	0.00	0.00	0.00	
A030	Multi-speed 10 setting	0.00	0.00	0.00	
A031	Multi-speed 11 setting	0.00	0.00	0.00	
A032	Multi-speed 12 setting	0.00	0.00	0.00	
A033	Multi-speed 13 setting	0.00	0.00	0.00	

“A” Group Parameters		Default Setting			User Setting
Func. Code	Name	FEF2, FE2 (Europe)	FU2, FU2 (U.S.A.)	FF2, F2 (Japan)	
A034	Multi-speed 14 setting	0.00	0.00	0.00	
A035	Multi-speed 15 setting	0.00	0.00	0.00	
A038	Jog frequency setting	1.00	1.00	1.00	
A039	Jog stop mode	00	00	00	
A041	Torque boost method selection	00	00	00	
A241	Torque boost method selection, 2nd motor	00	00	00	
A042	Manual torque boost value	1.0	1.0	1.0	
A242	Manual torque boost value, 2nd motor	1.0	1.0	1.0	
A342	Manual torque boost value, 3rd motor	1.0	1.0	1.0	
A043	Manual torque boost frequency adjustment	5.0	5.0	5.0	
A243	Manual torque boost frequency adjustment, 2nd motor	5.0	5.0	5.0	
A343	Manual torque boost frequency adjustment, 3rd motor	5.0	5.0	5.0	
A044	V/F characteristic curve selection	00	00	00	
A244	V/F characteristic curve selection, 2nd motor	00	00	00	
A344	V/F characteristic curve selection, 3rd motor	00	00	00	
A045	V/f gain setting	100.	100.	100.	
A046	Automatic torque boost voltage gain	100.	100.	100.	
A246	Automatic torque boost voltage gain, 2nd motor	100.	100.	100.	
A047	Automatic torque boost slip gain	100.	100.	100.	
A247	Automatic torque boost slip gain, 2nd motor	100.	100.	100.	
A051	DC braking enable	00	00	00	
A052	DC braking frequency setting	0.50	0.50	0.50	
A053	DC braking wait time	0.0	0.0	0.0	
A054	DC braking force during deceleration	0.	0.	0.	
A055	DC braking time for deceleration	0.0	0.0	0.0	
A056	DC braking / edge or level detection for [DB] input	01	01	01	
A057	DC braking force for starting	0.	0.	0.	
A058	DC braking time for starting	0.0	0.0	0.0	
A059	DC braking carrier frequency setting	5.0	5.0	5.0	
A061	Frequency upper limit setting	0.00	0.00	0.00	
A261	Frequency upper limit setting, 2nd motor	0.00	0.00	0.00	
A062	Frequency lower limit setting	0.00	0.00	0.00	
A262	Frequency lower limit setting, 2nd motor	0.00	0.00	0.00	
A063, A065, A067	Jump (center) frequency setting	0.00	0.00	0.00	

“A” Group Parameters		Default Setting			User Setting
Func. Code	Name	FEF2, FE2 (Europe)	FU2, FU2 (U.S.A.)	FF2, F2 (Japan)	
A064, A066, A068	Jump (hysteresis) frequency width setting	0.50	0.50	0.50	
A069	Acceleration stop frequency setting	0.00	0.00	0.00	
A070	Acceleration stop time frequency setting	0.0	0.0	0.0	
A071	PID Function Enable	00	00	00	
A072	PID proportional gain	1.0	1.0	1.0	
A073	PID integral time constant	1.0	1.0	1.0	
A074	PID derivative gain	0.0	0.0	0.0	
A075	PV scale conversion	1.00	1.00	1.00	
A076	PV source setting	00	00	00	
A077	Reverse PID action	00	00	00	
A078	PID output limit	0.00	0.00	0.00	
A079	PID feed forward select	00	00	00	
A081	AVR function select	00	00	02	
A082	AVR voltage select	230/400	230/460	200/400	
A085	Operation mode selection	00	00	00	
A086	Energy saving mode tuning	50.0	50.0	50.0	
A092	Acceleration (2) time setting	15.0	15.0	15.0	
A292	Acceleration (2) time setting, 2nd motor	15.0	15.0	15.0	
A392	Acceleration (2) time setting, 3rd motor	15.0	15.0	15.0	
A093	Deceleration (2) time setting	15.0	15.0	15.0	
A293	Deceleration (2) time setting, 2nd motor	15.0	15.0	15.0	
A393	Deceleration (2) time setting, 3rd motor	15.0	15.0	15.0	
A094	Select method to switch to Acc2/Dec2 profile	00	00	00	
A294	Select method to switch to Acc2/Dec2, 2nd motor	00	00	00	
A095	Acc1 to Acc2 frequency transition point	0.0	0.0	0.0	
A295	Acc1 to Acc2 frequency transition point, 2nd motor	0.0	0.0	0.0	
A096	Dec1 to Dec2 frequency transition point	0.0	0.0	0.0	
A296	Dec1 to Dec2 frequency transition point, 2nd motor	0.0	0.0	0.0	
A097	Acceleration curve selection	00	00	00	
A098	Deceleration curve setting	00	00	00	
A101	[OI]-[L] input active range start frequency	0.00	0.00	0.00	
A102	[OI]-[L] input active range end frequency	0.00	0.00	0.00	
A103	[OI]-[L] input active range start current	20.	20.	20.	
A104	[OI]-[L] input active range end current	100.	100.	100.	

“A” Group Parameters		Default Setting			User Setting
Func. Code	Name	FEF2, FE2 (Europe)	FU2, FU2 (U.S.A.)	FF2, F2 (Japan)	
A105	[OI]-[L] input start frequency enable	01	01	01	
A111	[O2]-[L] input active range start frequency	0.00	0.00	0.00	
A112	[O2]-[L] input active range end frequency	0.00	0.00	0.00	
A113	[O2]-[L] input active range start voltage	-100.	-100.	-100.	
A114	[O2]-[L] input active range end voltage	100.	100.	100.	
A131	Acceleration curve constants setting	02	02	02	
A132	Deceleration curve constants setting	02	02	02	
A141	A input select for calculate function	02	02	02	
A142	B input select for calculate function	03	03	03	
A143	Calculation symbol	00	00	00	
A145	ADD frequency	0.00	0.00	0.00	
A146	ADD direction select	00	00	00	
A150	EL-S curve acceleration ratio 1	25.	25.	25.	
A151	EL-S curve acceleration ratio 2	25.	25.	25.	
A152	EL-S curve acceleration ratio 3	25.	25.	25.	
A153	EL-S curve acceleration ratio 4	25.	25.	25.	

Fine Tuning Functions

“B” Group Parameters		Default Setting			User Setting
Func. Code	Name	FEF2, FE2 (Europe)	FU2, FU2 (U.S.A.)	FF2, F2 (Japan)	
B001	Selection of restart mode	00	00	00	
B002	Allowable under-voltage power failure time	1.0	1.0	1.0	
B003	Retry wait time before motor restart	1.0	1.0	1.0	
B004	Instantaneous power failure / under-voltage trip alarm enable	00	00	00	
B005	Number of restarts on power failure / under-voltage trip events	00	00	00	
B006	Phase loss detection enable	00	00	00	
B007	Restart frequency threshold	0.00	0.00	0.00	
B008	Retry after trip select	00	00	00	
B009	Retry after undervoltage select	00	00	00	
B010	Retry count select after overvoltage or overcurrent	3	3	3	
B011	Retry wait time after trip	1.0	1.0	1.0	
B012	Electronic thermal setting (calculated within the inverter from current output)	Rated current for each inverter			
B212	Electronic thermal setting (calculated within the inverter from current output), 2nd motor	Rated current for each inverter			
B312	Electronic thermal setting (calculated within the inverter from current output), 3rd motor	Rated current for each inverter			
B013	Electronic thermal characteristic	01	01	00	
B213	Electronic thermal characteristic, 2nd motor	01	01	00	
B313	Electronic thermal characteristic, 3rd motor	01	01	00	
B015	Free setting, electronic thermal frequency (1)	0.	0.	0.	
B016	Free setting, electronic thermal current (1)	0.0	0.0	0.0	
B017	Free setting, electronic thermal frequency (2)	0.	0.	0.	
B018	Free setting, electronic thermal current (2)	0.0	0.0	0.0	
B019	Free setting, electronic thermal frequency (3)	0.	0.	0.	
B020	Free setting, electronic thermal current (3)	0.0	0.0	0.0	
B021	Overload restriction operation mode	01	01	01	
B022	Overload restriction setting	Rated current x 1.50			
B023	Deceleration rate at overload restriction	1.0	1.0	1.0	
B024	Overload restriction operation mode (2)	01	01	01	
B025	Overload restriction setting (2)	Rated current x 1.50			
B026	Deceleration rate at overload restriction (2)	1.00	1.00	1.00	
B027	Overcurrent suppression enable	01	01	01	
B028	Current limit for active frequency-matching restart	Rated current x 1.0			

"B" Group Parameters		Default Setting			User Setting
Func. Code	Name	FEF2, FE2 (Europe)	FU2, FU2 (U.S.A.)	FF2, F2 (Japan)	
B029	Scan time constant for active freq. matching	0.50	0.50	0.50	
B030	Restart freq. select for active freq. matching	00	00	00	
B031	Software lock mode selection	01	01	01	
B034	Run/power-on warning time	0.	0.	0.	
B035	Rotational direction restriction	00	00	00	
B036	Reduced voltage start selection	06	06	06	
B037	Function code display restriction	04	04	04	
B038	Initial display selection	01	01	01	
B039	Automatic user parameter function enable	00	00	00	
B040	Torque limit selection	00	00	00	
B041	Torque limit (1) (forward-driving in 4-quadrant mode)	150.	150.	150.	
B042	Torque limit (2) (reverse-regenerating in 4-quadrant mode)	150.	150.	150.	
B043	Torque limit (3) (reverse-driving in 4-quadrant mode)	150.	150.	150.	
B044	Torque limit (4) (forward-regenerating in 4-quadrant mode)	150.	150.	150.	
B045	Torque limit LADSTOP enable	00	00	00	
B046	Reverse Run protection enable	00	00	00	
B050	Controller deceleration and stop on power loss	00	00	00	
B051	DC bus voltage trigger level during power loss	0.0	0.0	0.0	
B052	Over-voltage threshold during power loss	360.0/720.0	360.0/720.0	360.0/720.0	
B053	Deceleration time setting during power loss	1.00	1.00	1.00	
B054	Initial output frequency decrease during power loss	0.00	0.00	0.00	
B055	Proportional gain setting for non-stop operation at power loss	0.20	0.20	0.20	
B056	Integral time setting for non-stop operation at power loss	.100	.100	.100	
B060	[O] input max. limit level of window comparator	100	100	100	
B061	[O] input min. limit level of window comparator	0	0	0	
B062	[O] input hysteresis width of window comparator	0	0	0	
B063	[OI] input max. limit level of window comparator	100	100	100	
B064	[OI] input min. limit level of window comparator	0	0	0	
B065	[OI] input hysteresis width of window comparator	0	0	0	
B066	[O2] input maximum limit level of window comparator	100	100	100	
B067	[O2] input minimum limit level of window comparator	-100	-100	-100	

“B” Group Parameters		Default Setting			User Setting
Func. Code	Name	FEF2, FE2 (Europe)	FU2, FU2 (U.S.A.)	FF2, F2 (Japan)	
B068	[O2] input hysteresis width of window comparator	0	0	0	
B070	[O] input disconnect threshold	255(no)	255(no)	255(no)	
B071	[OI] input disconnect threshold	255(no)	255(no)	255(no)	
B072	[O2] input disconnect threshold	127(no)	127(no)	127(no)	
B078	Clear cumulative input power data	00	00	00	
B079	Cumulative input power display gain setting	1	1	1	
B082	Start frequency adjustment	0.50	0.50	0.50	
B083	Carrier frequency setting	3.0 2.1 1.9	3.0 2.1 1.9	3.0 2.1 1.9	
B084	Initialization mode (parameters or trip history)	00	00	00	
B085	Country code for initialization	01	02	00	
B086	Frequency scaling conversion factor	1.0	1.0	1.0	
B087	STOP key enable	00	00	00	
B088	Restart mode after FRS	00	00	00	
B089	Automatic carrier frequency reduction				
B090	Dynamic braking usage ratio	0.0	0.0	0.0	
B091	Stop mode selection	00	00	00	
B092	Cooling fan control	00	00	00	
B095	Dynamic braking control	00	00	00	
B096	Dynamic braking activation level	360/720	360/720	360/720	
B098	Thermistor for thermal protection control	00	00	00	
B099	Thermal protection level setting	3000.	3000.	3000.	
B100	Free-setting V/f frequency (1)	0.	0.	0.	
B101	Free-setting V/f voltage (1)	0.0	0.0	0.0	
B102	Free-setting V/f frequency (2)	0.	0.	0.	
B103	Free-setting V/f voltage (2)	0.0	0.0	0.0	
B104	Free-setting V/f frequency (3)	0.	0.	0.	
B105	Free-setting V/f voltage (3)	0.0	0.0	0.0	
B106	Free-setting V/f frequency (4)	0.	0.	0.	
B107	Free-setting V/f voltage (4)	0.0	0.0	0.0	
B108	Free-setting V/f frequency (5)	0.	0.	0.	
B109	Free-setting V/f voltage (5)	0.0	0.0	0.0	
B110	Free-setting V/f frequency (6)	0.	0.	0.	
B111	Free-setting V/f voltage (6)	0.0	0.0	0.0	
B112	Free-setting V/f frequency (7)	0.	0.	0.	
B113	Free-setting V/f voltage (7)	0.0	0.0	0.0	

“B” Group Parameters		Default Setting			User Setting
Func. Code	Name	FEF2, FE2 (Europe)	FU2, FU2 (U.S.A.)	FF2, F2 (Japan)	
B120	Brake Control Enable	00	00	00	
B121	Brake Wait Time for Release	0.00	0.00	0.00	
B122	Brake Wait Time for Acceleration	0.00	0.00	0.00	
B123	Brake Wait Time for Stopping	0.00	0.00	0.00	
B124	Brake Wait Time for Confirmation	0.00	0.00	0.00	
B125	Brake Release Frequency Setting	0.00	0.00	0.00	
B126	Brake Release Current Setting	Rated current for each inverter			
B127	Braking frequency	0.00	0.00	0.00	
B130	Over-voltage LADSTOP enable	00	00	00	
B131	Over-voltage LADSTOP level	380/760	380/760	380/760	
B132	Acceleration and deceleration rate at overvoltage suppression	1.0	1.0	1.0	
B133	Overvoltage suppression proportional gain	0.50	0.50	0.50	
B134	Overvoltage suppression integral time	0.060	0.060	0.060	

Intelligent Terminal Functions

“C” Group Parameters		Default Setting			User Setting
Func. Code	Name	FEF2, FE2 (Europe)	FU2, FU2 (U.S.A.)	FF2, F2 (Japan)	
C001	Terminal [1] function	18	18	18	
C002	Terminal [2] function	16	16	16	
C003	Terminal [3] function	06	06	06	
C004	Terminal [4] function	11	11	11	
C005	Terminal [5] function	09	09	09	
C006	Terminal [6] function	03	13	03	
C007	Terminal [7] function	02	02	02	
C008	Terminal [8] function	01	01	01	
C011	Terminal [1] active state	00	00	00	
C012	Terminal [2] active state	00	00	00	
C013	Terminal [3] active state	00	00	00	
C014	Terminal [4] active state	00	00	00	
C015	Terminal [5] active state	00	00	00	
C016	Terminal [6] active state	00	00	00	
C017	Terminal (7) active state	00	00	00	
C018	Terminal [8] active state	00	00	00	

“C” Group Parameters		Default Setting			User Setting
Func. Code	Name	FEF2, FE2 (Europe)	FU2, FU2 (U.S.A.)	FF2, F2 (Japan)	
C019	Terminal [FW] active state	00	00	00	
C021	Terminal [11] function	01	01	01	
C022	Terminal [12] function	00	00	00	
C023	Terminal [13] function	03	03	03	
C024	Terminal [14] function	07	07	07	
C025	Terminal [15] function	08	08	08	
C026	Alarm relay terminal function	05	05	05	
C027	[FM] signal selection	00	00	00	
C028	[AM] signal selection	00	00	00	
C029	[AMI] signal selection	00	00	00	
C030	Digital current monitor reference value	Rated current x 1.0			
C031	Terminal [11] active state	00	00	00	
C032	Terminal [12] active state	00	00	00	
C033	Terminal [13] active state	00	00	00	
C034	Terminal [14] active state	00	00	00	
C035	Terminal [15] active state	00	00	00	
C036	Alarm relay active state	01	01	01	
C038	Low current indication output mode select	01	01	01	
C039	Low current indication detection level	Rated current x 1.0			
C040	Overload signal output mode	01	01	01	
C041	Overload level setting	Rated current for each inverter			
C042	Frequency arrival setting for accel.	0.00	0.00	0.00	
C043	Arrival frequency setting for decel.	0.00	0.00	0.00	
C044	PID deviation level setting	3.0	3.0	3.0	
C045	Frequency arrival setting for acceleration (2)	0.00	0.00	0.00	
C046	Frequency arrival setting for deceleration (2)	0.00	0.00	0.00	
C052	Maximum PID feedback (PV) data	0.00	0.00	0.00	
C053	Minimum PID feedback (PV) data	100.0	100.0	100.0	
C055	Over-torque (forward-driving) level setting	100.	100.	100.	
C056	Over-torque (reverse regenerating) level setting	100.	100.	100.	
C057	Over-torque (reverse driving) level setting	100.	100.	100.	
C058	Over-torque (forward regenerating) level setting	100.	100.	100.	
C061	Electronic thermal warning level setting	80.	80.	80.	
C062	Alarm code output	00	00	00	
C063	Zero speed detection level	0.00	0.00	0.00	
C064	Heatsink overheat warning level	120	120	120	

“C” Group Parameters		Default Setting			User Setting
Func. Code	Name	FEF2, FE2 (Europe)	FU2, FU2 (U.S.A.)	FF2, F2 (Japan)	
C071	Communication speed selection	04	04	04	
C072	Node allocation	1.	1.	1.	
C073	Communication data length selection	7	7	7	
C074	Communication parity selection	00	00	00	
C075	Communication stop bit selection	1	1	1	
C076	Action upon communication error selection	02	02	02	
C077	Communication timeout before trip	0.00	0.00	0.00	
C078	Communication wait time	0.	0.	0.	
C079	Communication protocol select	00	00	00	
C081	[O] input span calibration	Factory set	Factory set	Factory set	
C082	[OI] input span calibration	Factory set	Factory set	Factory set	
C083	[O2] input span calibration	Factory set	Factory set	Factory set	
C085	Thermistor input tuning	105.0	105.0	105.0	
C086	[AM] terminal offset tuning	0.0	0.0	0.0	
C087	[AMI] terminal meter tuning	80.	80.	80.	
C088	[AMI] terminal offset tuning	Factory set	Factory set	Factory set	
C091	Debug mode enable	00	00	00	Do not edit
C101	Up/Down memory mode selection	00	00	00	
C102	Reset mode selection	00	00	00	
C103	Restart mode after reset	00	00	00	
C105	FM gain adjustment	100.	100.	100.	
C106	AM gain adjustment	100.	100.	100.	
C107	AMI gain adjustment	100.	100.	100.	
C109	AM bias adjustment	0.	0.	0.	
C110	AMI bias adjustment	20.	20.	20.	
C111	Overload setting (2)	Rated current for each inverter model			
C121	[O] input zero calibration	Factory set			
C122	[OI] input zero calibration	Factory set			
C123	[O2] input zero calibration	Factory set			
C130	Terminal [11] ON-delay time	0.0	0.0	0.0	
C131	Terminal [11] OFF-delay time	0.0	0.0	0.0	
C132	Terminal [12] ON-delay time	0.0	0.0	0.0	
C133	Terminal [12] OFF-delay time	0.0	0.0	0.0	
C134	Terminal [13] ON-delay time	0.0	0.0	0.0	
C135	Terminal [13] OFF-delay time	0.0	0.0	0.0	
C136	Terminal [14] ON-delay time	0.0	0.0	0.0	

“C” Group Parameters		Default Setting			User Setting
Func. Code	Name	FEF2, FE2 (Europe)	FU2, FU2 (U.S.A.)	FF2, F2 (Japan)	
C137	Terminal [14] OFF-delay time	0.0	0.0	0.0	
C138	Terminal [15] ON-delay time	0.0	0.0	0.0	
C139	Terminal [15] OFF-delay time	0.0	0.0	0.0	
C140	Relay output ON-delay time	0.0	0.0	0.0	
C141	Relay output OFF-delay time	0.0	0.0	0.0	
C142	Logic output 1 function A	00	00	00	
C143	Logic output 1 function B	00	00	00	
C144	Logic output 1 operator	00	00	00	
C145	Logic output 2 function A	00	00	00	
C146	Logic output 2 function B	00	00	00	
C147	Logic output 2 operator	00	00	00	
C148	Logic output 3 function A	00	00	00	
C149	Logic output 3 function B	00	00	00	
C150	Logic output 3 operator	00	00	00	
C151	Logic output 4 function A	00	00	00	
C152	Logic output 4 function B	00	00	00	
C153	Logic output 4 operator	00	00	00	
C154	Logic output 5 function A	00	00	00	
C155	Logic output 5 function B	00	00	00	
C156	Logic output 5 operator	00	00	00	
C157	Logic output 6 function A	00	00	00	
C158	Logic output 6 function B	00	00	00	
C159	Logic output 6 operator	00	00	00	
C160	Terminal [1] input response time setting	1	1	1	
C161	Terminal [2] input response time setting	1	1	1	
C162	Terminal [3] input response time setting	1	1	1	
C163	Terminal [4] input response time setting	1	1	1	
C164	Terminal [5] input response time setting	1	1	1	
C165	Terminal [6] input response time setting	1	1	1	
C166	Terminal [7] input response time setting	1	1	1	
C167	Terminal [8] input response time setting	1	1	1	
C168	Terminal [FW] input response time setting	1	1	1	
C169	Multi-speed position determination time	0	0	0	

Motor Constants Functions

“H” Group Parameters		Default Setting			User Setting
Func. Code	Name	FEF2, FE2 (Europe)	FU2, FU2 (U.S.A.)	FF2, F2 (Japan)	
H001	Auto-tuning setting	00	00	00	
H002	Motor data selection, 1st motor	00	00	00	
H202	Motor data selection, 2nd motor	00	00	00	
H003	Motor capacity, 1st motor	Factory set			
H203	Motor capacity, 2nd setting	Factory set			
H004	Motor poles setting, 1st motor	4	4	4	
H204	Motor poles setting, 2nd motor	4	4	4	
H005	Motor speed constant, 1st motor	1.590	1.590	1.590	
H205	Motor speed constant, 2nd motor	1.590	1.590	1.590	
H006	Motor stabilization constant, 1st motor	100.	100.	100.	
H206	Motor stabilization constant, 2nd motor	100.	100.	100.	
H306	Motor stabilization constant, 3rd motor	100.	100.	100.	
H020	Motor constant R1, 1st motor	According to inverter rating			
H220	Motor constant R1, 2nd motor	According to inverter rating			
H021	Motor constant R2, 1st motor	According to inverter rating			
H221	Motor constant R2, 2nd motor	According to inverter rating			
H022	Motor constant L, 1st motor	According to inverter rating			
H222	Motor constant L, 2nd motor	According to inverter rating			
H023	Motor constant Io	According to inverter rating			
H223	Motor constant Io, 2nd motor	According to inverter rating			
H024	Motor Constant J	According to inverter rating			
H224	Motor constant J, 2nd motor	According to inverter rating			
H030	Auto constant R1, 1st motor	According to inverter rating			
H230	Auto constant R1, 2nd motor	According to inverter rating			
H031	Auto constant R2, 1st motor	According to inverter rating			
H231	Auto constant R2, 2nd motor	According to inverter rating			
H032	Auto constant L, 1st motor	According to inverter rating			
H232	Auto constant L, 2nd motor	According to inverter rating			
H033	Auto constant Io, 1st motor	According to inverter rating			
H233	Auto constant Io, 2nd motor	According to inverter rating			
H034	Auto constant J, 1st motor	According to inverter rating			
H234	Auto constant J, 2nd motor	According to inverter rating			
H050	PI proportional gain for 1st motor	100.0	100.0	100.0	
H250	PI proportional gain for 2nd motor	100.0	100.0	100.0	

“H” Group Parameters		Default Setting			User Setting
Func. Code	Name	FEF2, FE2 (Europe)	FU2, FU2 (U.S.A.)	FF2, F2 (Japan)	
H051	PI integral gain for 1st motor	100.0	100.0	100.0	
H251	PI integral gain for 2nd motor	100.0	100.0	100.0	
H052	P proportional gain setting for 1st motor	1.00	1.00	1.00	
H252	P proportional gain setting for 2nd motor	1.00	1.00	1.00	
H060	Zero LV limit for 1st motor	100.	100.	100.	
H260	Zero LV limit for 2nd motor	100.	100.	100.	
H061	Zero LV starting boost current for 1st motor	50.	50.	50.	
H261	Zero LV starting boost current for 2nd motor	50.	50.	50.	
H070	Terminal selection PI proportional gain setting	100.0	100.0	100.0	
H071	Terminal selection PI integral gain setting	100.0	100.0	100.0	
H072	Terminal selection P proportional gain setting	1.00	1.00	1.00	
H073	Gain switching time	100.	100.	100.	

Expansion Card Functions

“P” Group Parameters		Default Setting			User Setting
Func. Code	Name	FEF2, FE2 (Europe)	FU2, FU2 (U.S.A.)	FF2, F2 (Japan)	
P001	Operation mode on expansion card 1 error	00	00	00	
P002	Operation mode on expansion card 2 error	00	00	00	
P011	Encoder pulse-per-revolution (PPR) setting	1024	1024	1024	
P012	Control pulse setting	00	00	00	
P013	Pulse line mode setting	00	00	00	
P014	Home search stop position setting	0.	0.	0.	
P015	Home search speed setting	5.00	5.00	5.00	
P016	Home search direction setting	00	00	00	
P017	Home search completion range setting	5	5	5	
P018	Home search completion delay time setting	0.00	0.00	0.00	
P019	Electronic gear set position selection	00	00	00	
P020	Electronic gear ratio numerator setting	1.	1.	1.	
P021	Electronic gear ratio denominator setting	1.	1.	1.	
P022	Feed-forward gain setting	0.00	0.00	0.00	
P023	Position loop gain setting	0.50	0.50	0.50	
P024	Position bias setting	0.	0.	0.	
P025	Temperature compensation thermistor enable	00	00	00	
P026	Over-speed error detection level setting	135.0	135.0	135.0	
P027	Speed deviation error detection level setting	7.50	7.50	7.50	
P028	Numerator of motor gear ratio	1.	1.	1.	
P029	Denominator of motor gear ratio	1.	1.	1.	
P031	Accel/decel time input selection	00	00	00	
P032	Positioning command input selection	00	00	00	
P033	Torque command input selection	00	00	00	
P034	Torque command setting	0.	0.	0.	
P035	Torque command polarity select	00	00	00	
P036	Torque bias mode	00	00	00	
P037	Torque bias value	0.	0.	0.	
P038	Torque bias polarity selection	00	00	00	
P039	Forward maximum speed for torque-controlled operation	0.00	0.00	0.00	
P040	Reverse maximum speed for torque-controlled operation	0.00	0.00	0.00	
P044	DeviceNet comm watchdog timer	01	01	01	

“P” Group Parameters		Default Setting			User Setting
Func. Code	Name	FEF2, FE2 (Europe)	FU2, FU2 (U.S.A.)	FF2, F2 (Japan)	
P045	Inverter action on DeviceNet comm error	21	21	21	
P046	DeviceNet polled I/O: Output instance number	71	71	71	
P047	DeviceNet polled I/O: Input instance number	01	01	01	
P048	Inverter action on DeviceNet idle mode	0	0	0	
P049	Motor poles setting for RPM	01	01	01	
P055	Pulse train frequency span	25.0	25.0	25.0	
P056	Pulse train frequency time constant	0.10	0.10	0.10	
P057	Pulse train frequency bias	0.	0.	0.	
P058	Pulse train frequency limit	100.	100.	100.	
P060	Multi-stage position setting 0	0	0	0	
P061	Multi-stage position setting 1	0	0	0	
P062	Multi-stage position setting 2	0	0	0	
P063	Multi-stage position setting 3	0	0	0	
P064	Multi-stage position setting 4	0	0	0	
P065	Multi-stage position setting 5	0	0	0	
P066	Multi-stage position setting 6	0	0	0	
P067	Multi-stage position setting 7	0	0	0	
P068	Home position mode selection	00	00	00	
P069	Home position direction selection	00	00	00	
P070	Low speed homing frequency	0.00	0.00	0.00	
P071	High speed homing frequency	0.00	0.00	0.00	
P072	Forward position range setting	268435455	268435455	268435455	
P073	Reverse position range setting	– 268435455	– 268435455	– 268435455	
P074	Position teaching selection	00	00	00	
P100	Easy sequence parameter (U00)	0.	0.	0.	
P101	Easy sequence parameter (U01)	0.	0.	0.	
P102	Easy sequence parameter (U02)	0.	0.	0.	
P103	Easy sequence parameter (U03)	0.	0.	0.	
P104	Easy sequence parameter (U04)	0.	0.	0.	
P105	Easy sequence parameter (U05)	0.	0.	0.	
P106	Easy sequence parameter (U06)	0.	0.	0.	
P107	Easy sequence parameter (U07)	0.	0.	0.	
P108	Easy sequence parameter (U08)	0.	0.	0.	
P109	Easy sequence parameter (U09)	0.	0.	0.	
P110	Easy sequence parameter (U10)	0.	0.	0.	
P111	Easy sequence parameter (U11)	0.	0.	0.	

"P" Group Parameters		Default Setting			User Setting
Func. Code	Name	FEF2, FE2 (Europe)	FU2, FU2 (U.S.A.)	FF2, F2 (Japan)	
P112	Easy sequence parameter (U12)	0.	0.	0.	
P113	Easy sequence parameter (U13)	0.	0.	0.	
P114	Easy sequence parameter (U14)	0.	0.	0.	
P115	Easy sequence parameter (U15)	0.	0.	0.	
P116	Easy sequence parameter (U16)	0.	0.	0.	
P117	Easy sequence parameter (U17)	0.	0.	0.	
P118	Easy sequence parameter (U18)	0.	0.	0.	
P119	Easy sequence parameter (U19)	0.	0.	0.	
P120	Easy sequence parameter (U20)	0.	0.	0.	
P121	Easy sequence parameter (U21)	0.	0.	0.	
P122	Easy sequence parameter (U22)	0.	0.	0.	
P123	Easy sequence parameter (U23)	0.	0.	0.	
P124	Easy sequence parameter (U24)	0.	0.	0.	
P125	Easy sequence parameter (U25)	0.	0.	0.	
P126	Easy sequence parameter (U26)	0.	0.	0.	
P127	Easy sequence parameter (U27)	0.	0.	0.	
P128	Easy sequence parameter (U28)	0.	0.	0.	
P129	Easy sequence parameter (U29)	0.	0.	0.	
P130	Easy sequence parameter (U30)	0.	0.	0.	
P131	Easy sequence parameter (U31)	0.	0.	0.	

User-selectable Menu Functions

“P” Group Parameters		Default Setting			User Setting
Func. Code	Name	FEF2, FE2 (Europe)	FU2, FU2 (U.S.A.)	FF2, F2 (Japan)	
U001	User-selected function... “no” = disabled, or use any of the functions D001 to P049	no	no	no	
U002		no	no	no	
U003		no	no	no	
U004		no	no	no	
U005		no	no	no	
U006		no	no	no	
U007		no	no	no	
U008		no	no	no	
U009		no	no	no	
U010		no	no	no	
U011		no	no	no	
U012		no	no	no	



CE-EMC Installation Guidelines

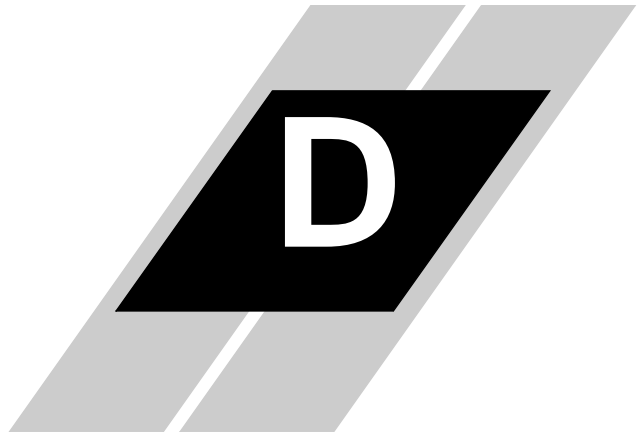

In This Appendix....	page
— CE-EMC Installation Guidelines	2
— Precautions for EMC, Models SJ700-004 to -1500	4
— Precautions for EMC, Models SJ700-1850 to -4000	5

CE-EMC Installation Guidelines

You are required to satisfy the EMC directive (89/336/EEC) when using an SJ7002 inverter in an EU country. To satisfy the EMC directive and to comply with standard, follow the guidelines in this section.

- 1. As user you must ensure that the HF (high frequency) impedance between adjustable frequency inverter, filter, and ground is as small as possible.**
 - Ensure that the connections are metallic and have the largest possible contact areas (zinc-plated mounting plates).
- 2. Avoid conductor loops that act like antennas, especially loops that encompass large areas.**
 - Avoid unnecessary conductor loops.
 - Avoid parallel arrangement of low-level signal wiring and power-carrying or noise-prone conductors.
- 3. Use shielded wiring for the motor cable and all analog and digital control lines.**
 - Allow the effective shield area of these lines to remain as large as possible; i.e., do not strip away the shield (screen) further away from the cable end than absolutely necessary.
 - With integrated systems (for example, when the adjustable frequency inverter is communicating with some type of supervisory controller or host computer in the same control cabinet and they are connected at the same PE-potential), connect the shields of the control lines to ground + PE (protective earth) at both ends. With distributed systems (for example the communicating supervisory controller or host computer is not in the same control cabinet and there is a distance between the systems), we recommend connecting the shield of the control lines only at the end connecting to the adjustable frequency inverter. If possible, route the other end of the control lines directly to the cable entry section of the supervisory controller or host computer. The shield conductor of the motor cables always must be connected to PE at both ends.
 - To achieve a large area contact between shield and PE-potential, use a PG screw with a metallic shell, or use a metallic mounting clip.
 - Use only cable with braided, tinned copper mesh shield (type "CY") with 85% coverage.
 - The shielding continuity should not be broken at any point in the cable. If the use of reactors, contactors, terminals, or safety switches in the motor output is necessary, the unshielded section should be kept as short as possible.
 - Some motors have a rubber gasket between terminal box and motor housing. Very often, the terminal boxes, and particularly the threads for the metal PG screw connections, are painted. Make sure there is always a good metallic connection between the shielding of the motor cable, the metal PG screw connection, the terminal box, and the motor housing. If necessary, carefully remove paint between conducting surfaces.
- 4. Take measures to minimize interference that is frequently coupled in through installation cables.**
 - Separate interfering cables with 0.25m minimum from cables susceptible to interference. A particularly critical point is laying parallel cables over longer distances. If two cables intersect (one crosses over the other), the interference is smallest if they intersect at an angle of 90°. Cables susceptible to interference should therefore only intersect motor cables, intermediate circuit cables, or the wiring of a rheostat at right angles and never be laid parallel to them over longer distances.
- 5. Minimize the distance between an interference source and an interference sink (interference-threatened device), thereby decreasing the effect of the emitted interference on the interference sink.**
 - You should use only interference-free devices and maintain a minimum distance of 0.25 m from the adjustable frequency inverter.

6. Follow safety measures in the filter installation.

- Ensure that the protective earth terminal (PE) of the filter is properly connected to the PE terminal of the adjustable frequency inverter. An **HF ground connection** via metal contact between the housings of the filter and the adjustable frequency inverter, or solely via cable shield, *is not permitted as a protective conductor connection*. The *filter must be solidly and permanently connected with the ground potential* so as to preclude the danger of electric shock upon touching the filter if a fault occurs.

To achieve a protective ground connection for the filter:

- Ground the filter with a conductor of at least 10 mm² cross-sectional area.
- Connect a second grounding conductor, using a separate grounding terminal parallel to the protective conductor. (The cross section of each single protective conductor terminal must be sized for the required nominal load.)

SJ7002 inverter with book-type filter

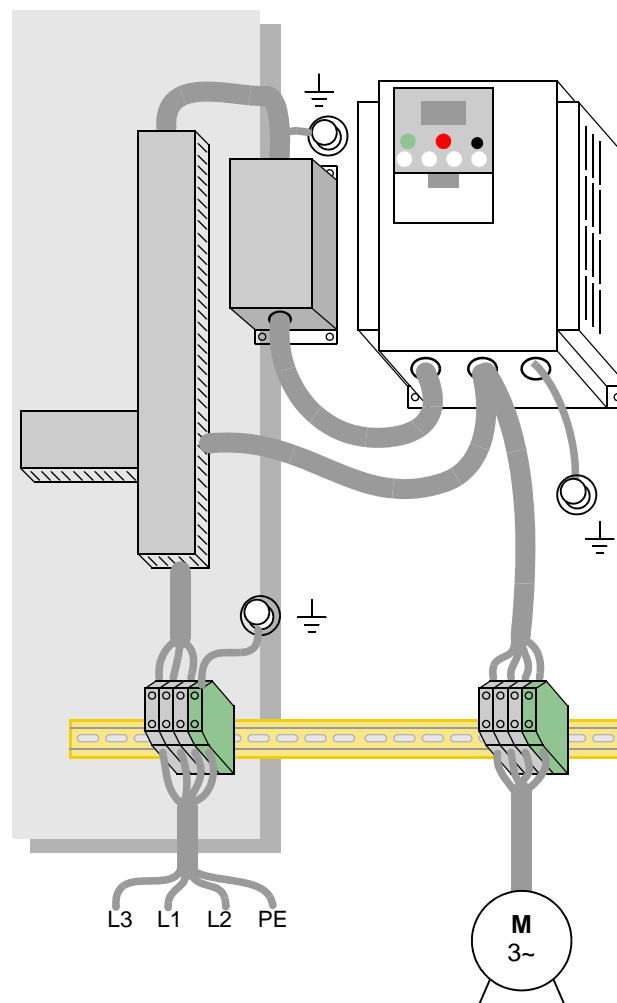

Precautions for EMC, Models SJ700-004 to -1500

The SJ7002 series inverter conforms to the requirements of Electromagnetic Compatibility (EMC) Directive (2004/108/EC). However, when using the inverter in Europe, you must comply with the following specifications and requirements to meet the EMC Directive and other standards in Europe:



WARNING: This equipment must be installed, adjusted, and maintained by qualified engineers who have expert knowledge of electric work, inverter operation, and the hazardous circumstances that can occur. Otherwise, personal injury may result.

Use the following checklist to ensure the inverter is within proper operating ranges and conditions.

1. Power supply requirements
 - a. Voltage fluctuation must be -15% to +10% or less.
 - b. Voltage imbalance must be $\pm 3\%$ or less.
 - c. Frequency variation must be $\pm 4\%$ or less
 - d. Total harmonic distortion (THD) of voltage must be $\pm 10\%$ or less.
2. Installation requirement
 - a. A special filter intended for the SJ7002 series inverter must be installed.
3. Wiring requirements
 - a. A shielded wire (screened cable) must be used for motor wiring, and the length must be according to the following table below.
 - b. The carrier frequency must be set according to the following table to meet an EMC requirement.
 - c. The main circuit wiring must be separated from the control circuit wiring.
4. Environmental requirements (to be met when a filter is used)
 - a. Ambient temperature must be within the range -10°C to 40°C .
 - b. Relative humidity must be within the range 20% to 90% (non-condensing).
 - c. Vibrations must be
 - 5.9 m/sec² (0.6 G) (10 to 55Hz) or less (0.4 to 22kW).
 - 2.94 m/sec² (0.3 G) (10 to 55Hz) or less (30 to 150kW).
 - d. The inverter must be installed indoors (not exposed to corrosive gases and dust) at an altitude of 1,000 m or less.

Models	Cat.	Cable length (m)	Carrier freq. (kHz)	Models	Cat.	Cable length (m)	Carrier freq. (kHz)
SJ700-004L	C3	5	2.5	—	—	—	—
SJ700-007L	C3	5	2.5	SJ700-007H	C3	5	2.5
SJ700-015L	C3	5	2.5	SJ700-015H	C3	5	2.5
SJ700-022L	C3	5	2.5	SJ700-022H	C3	5	2.5
SJ700-037L	C3	5	2.5	SJ700-040H	C3	5	2.5
SJ700-055L	C3	1	1	SJ700-055H	C3	1	2.5
SJ700-075L	C3	1	1	SJ700-075H	C3	1	2.5
SJ700-110L	C3	1	1	SJ700-110H	C3	1	2.5
SJ700-150L	C3	1	1	SJ700-150H	C3	1	2.5
SJ700-185L	C3	1	1	SJ700-185H	C3	1	2.5
SJ700-220L	C3	5	2.5	SJ700-220H	C3	1	2.5

Models	Cat.	Cable length (m)	Carrier freq. (kHz)	Models	Cat.	Cable length (m)	Carrier freq. (kHz)
SJ700-300L	C3	5	2.5	SJ700-300H	C3	1	2.5
SJ700-370L	C3	5	2.5	SJ700-370H	C3	1	2.5
SJ700-450L	C3	5	2.5	SJ700-450H	C3	5	2.5
SJ700-550L	C3	5	2.5	SJ700-550H	C3	5	2.5
				SJ700-750H	C3	10	2.5
				SJ700-900H	C3	10	2.5
				SJ700-1100H	C3	10	2.5
				SJ700-1320H	C3	10	2.5
				SJ700-1500H	C3	10	2.5

Precautions for EMC, Models SJ700-1850 to -4000

The SJ7002 series inverter conforms to the requirements of Electromagnetic Compatibility (EMC) Directive (2004/108/EC). However, when using the inverter in Europe, you must comply with the following specifications and requirements to meet the EMC Directive and other standards in Europe:



WARNING: This equipment must be installed, adjusted, and maintained by qualified engineers who have expert knowledge of electric work, inverter operation, and the hazardous circumstances that can occur. Otherwise, personal injury may result.

Use the following checklist to ensure the inverter is within proper operating ranges and conditions.

1. Power supply requirements
 - a. Voltage fluctuation must be -15% to $+10\%$ or less.
 - b. Voltage imbalance must be $\pm 3\%$ or less.
 - c. Frequency variation must be $\pm 4\%$ or less.
 - d. Total harmonic distortion (THD) of voltage must be $\pm 10\%$ or less.
2. Installation requirements
 - a. A special filter and a ferrite core intended for the SJ7002 large capacity series inverter must be installed, shown in the table below.
 - b. A provided direct reactor with the SJ700 large capacity series inverter must be installed.

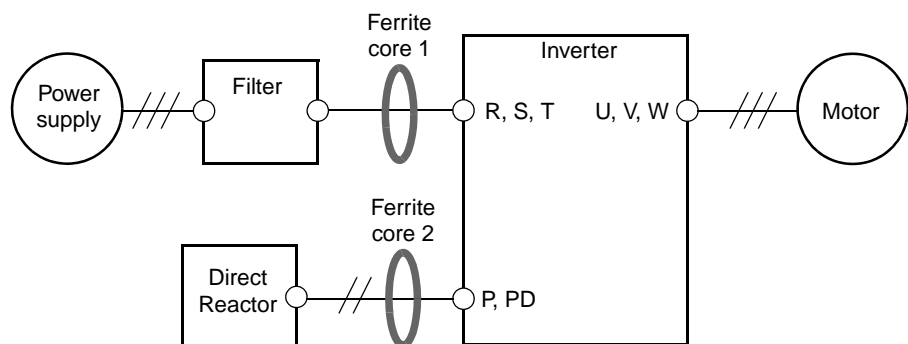

Models	Category C2			Category C3		
	Filter	Ferrite Core 1	Ferrite Core 2	Filter	Ferrite Core 1	Ferrite Core 2
SJ700-1850HFU2/HFE2	✓	✓	✗	✗	✗	✗
SJ700-3150HFU2/HFE2	✓	✗	✗	✗	✗	✗
SJ700-4000HFU2/HFE2	✓	✓	✗	✗	✗	✗

✓ = Installation

✗ = No installation

3. Wiring requirements

- a. Shielded wire (screened cable) is required for motor wiring but is not required for direct reactor wiring. And, the length of the cable must be according to the following table.
- b. The carrier frequency setting must be less than 3 kHz (derated is required) to meet an EMC requirement.
- c. The main circuit wiring must be separated from the control circuit wiring.

4. Environmental requirements (to be met when a filter is used)

- a. Ambient temperature must be within the range -10°C to 40°C.
- b. Relative humidity must be within the range 20% to 90% (non-condensing).
- c. Vibrations must be 1.96 m/sec² (0.2 G) (10 to 55Hz) or less.
- d. The inverter must be installed indoors (not exposed to corrosive gas and dust) at an altitude of 1,000 m or less.

Models	Cable length (m)	
	to motor	to DC reactor
SJ700-1850HFU2/HFE2	5	5
SJ700-3150HFU2/HFE2	10	5
SJ700-4000HFU2/HFE2	10	5

Index

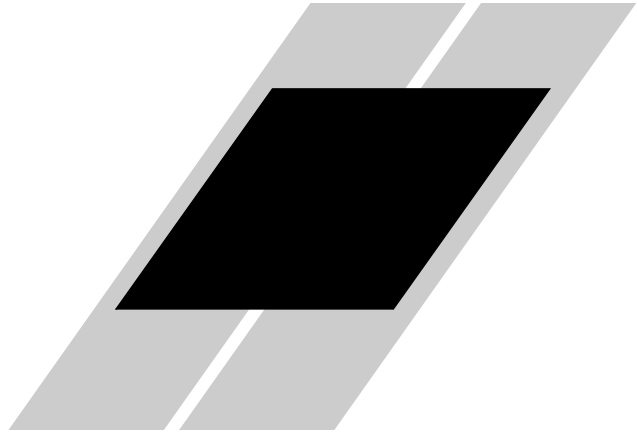

A

A Group functions [3-10](#)
Absolute Position Control Mode [3-72](#)
AC reactors [5-3](#)
Acceleration [1-16](#), [3-9](#)
 characteristic curves [3-26](#)
 second function [3-24](#)
 two-stage [4-20](#)
Acceleration stop function [3-21](#)
Access levels [3-5](#), [3-38](#), [4-23](#)
Access to terminals [2-2](#)
Accessories [5-2](#)
Adaptive auto-tuning [4-73](#)
ADD frequency enable [4-34](#)
Alarm signal [4-47](#)
Algorithms [3-66](#)
Algorithms, torque control [3-5](#)
Ambient temperature [2-8](#), [A-2](#)
Analog disconnect detection [4-55](#)
Analog input settings [3-11](#), [3-27](#)
Analog inputs
 current/voltage select [4-24](#)
 operation [4-63](#)
 sampling filter [4-63](#)
 wiring examples [4-65](#)
Analog outputs
 FM type [4-67](#)
 operation [4-66](#)
 PWM type [4-66](#)
Analog signal calibration [3-62](#)
Anti-windmilling [3-18](#), [3-21](#)
Arrival frequency [A-2](#)
ASCII code table [B-19](#)
ASCII mode communications [B-5](#)
Automatic restart [3-30](#)
Automatic voltage regulation [3-23](#)
Auto-tuning [4-71](#), [A-2](#)
 adaptive [4-73](#)
 procedure [4-72](#)
Auto-tuning constants [3-66](#)
AVR [3-23](#)

B

B Group functions [3-30](#)
Base frequency [2-32](#), [A-2](#)
Bibliography [A-6](#)
Block check code [B-19](#)
Brake control, external [3-48](#), [4-32](#), [4-54](#)
Braking [1-16](#)
 dynamic [5-6](#)
Braking resistor [2-5](#), [A-2](#)
Braking resistor selection [5-7](#)
Braking unit [2-5](#)
Braking, dynamic [1-19](#)
Break-away torque [A-2](#)

C

C Group functions [3-50](#)
Capacitor life curve [6-20](#)
Capacitor life warning [4-58](#)
Capacitor replacement [6-21](#)
Carrier frequency [3-44](#), [A-2](#)
Catching a spinning motor [3-45](#), [3-62](#)
CE approval [A-2](#)
CE-EMC guidelines [D-2](#)
Chassis ground connection [2-26](#)
Choke [2-5](#), [A-2](#)
Choke, DC link [5-4](#)
Chopper frequency [3-44](#)
Circuit breaker sizes [xv](#)
Clear cumulative power value [4-36](#)
Clearance [2-8](#)
Coasting [3-45](#), [3-62](#)
Commercial power source enable [4-22](#)
Communication test mode [B-20](#)
Communications [3-61](#)
Communications protocol, ASCII [B-5](#)
Communications protocol, ModBus [B-21](#)
Communications, serial [B-2](#)
Constant torque [3-15](#)
Constant volts/hertz operation [1-14](#)

Control algorithms [3-14](#)
Control gain switching [4-26](#)
Controlled deceleration [3-42](#)
Controlled deceleration at power loss [4-4](#)
Cooling fan control [3-47](#)
Copy Unit [1-3](#)
Current forcing [4-37](#)
Current overload [3-36](#)
Current overload restriction [4-29](#)

D

D Group parameters [3-6](#)
DC braking [4-18](#), [4-19](#), [A-2](#)
 derating [3-20](#)
 settings [3-18](#)
DC link [A-2](#)
 choke [5-4](#)
Deadband [A-2](#)
Deceleration [1-16](#), [3-9](#), [4-18](#)
 characteristic curves [3-26](#)
 second function [3-24](#)
 two-stage [4-20](#)
Default parameter values [C-2](#)
Default settings
 restoring [6-16](#)
Derating
 DC braking [3-20](#)
Derivative gain [3-22](#)
DeviceNet [5-5](#)
Digital operator [2-29](#), [3-3](#)
 force operation [4-28](#)
 removal [2-4](#)
Digital operator panel [A-2](#)
Digital operators [1-3](#)
Dimensions
 inverter [2-9](#)
 terminals [2-20](#)
Diode [A-3](#)
Display restriction [3-39](#)
Droop control [4-27](#)
Duty cycle [A-3](#)
Dynamic braking [5-6](#), [A-3](#)
 usage ratio [3-47](#), [5-6](#)

E

Easy sequence [4-38](#)
Editing parameters [2-29](#), [2-32](#)
 in Run Mode [3-5](#), [3-38](#), [4-23](#)
Electromagnetic compatibility [D-2](#)
Electronic thermal overload [3-32](#)
Elevator braking [3-48](#)
EMC installation guidelines [D-2](#)
EMC installation precautions [D-4](#)
Emergency Stop function [2-37](#)
EMI [A-3](#)
EMI filter [5-4](#)
Encoder feedback [3-17](#)
Energy savings mode [3-23](#)

Error
 PID loop [4-46](#), [A-3](#)
Error codes
 programming [3-75](#)
 trip events [6-6](#)
Event clearing [4-24](#)
Expansion bay [2-4](#)
Expansion card functions [3-69](#)
Expansion cards
 digital input [5-5](#)
 encoder feedback [5-5](#)
 input signals [4-34](#)
 output signals [4-54](#)
External brake control [4-32](#), [4-54](#)
External trip [4-21](#)

F

F Group functions [3-9](#)
Factory settings, restoring [6-16](#)
Fan default setting [3-47](#)
Fan outlet [2-8](#), [2-26](#)
Fan replacement [6-23](#)
Fan unit, Filler plate [1-4](#)
FAQ [1-18](#)
Features [1-2](#), [2-2](#)
Ferrite core [5-4](#)
Filters
 noise suppression [5-2](#)
Fine-tuning functions [3-30](#)
Force operation from digital operator [4-28](#)
Force terminal mode [4-35](#)
Forward run command [4-15](#)
Forward/reverse drive stop [4-41](#)
Forward/reverse rotation signals [4-61](#)
Four-quadrant operation [A-3](#)
Free-run stop [3-45](#), [3-62](#), [4-18](#), [4-20](#), [A-3](#)
Frequency arrival signals [4-44](#)
Frequency matching [3-45](#), [3-62](#)
Frequency setting [A-3](#)
Frequency-related functions [3-20](#)
Frequently asked questions [1-18](#)
Functions [1-16](#)
Fuse ratings [2-18](#)
Fuse sizes [xv](#)
Fuzzy logic accel/decel [3-23](#)

G

Gain settings [4-26](#)
General output signals [4-60](#)
General purpose inputs [4-38](#)
Glossary of terms [A-2](#)
Grommets [2-17](#)

H

H Group parameters [3-66](#)
 Harmonics [A-3](#)
 Heatsink overheat warning [4-59](#)
 History of trip events [3-8](#)
 Home search [A-4](#)
 Horsepower [A-3](#)

I

IGBT [1-14](#), [A-3](#)
 test method [6-27](#)
 Index of terminal functions [4-11](#)
 Inertia [A-3](#)
 Initialization [6-16](#)
 Input active range [3-27](#)
 Input circuits [4-13](#)
 Input terminals [2-22](#)
 Inspection
 electrical measurements [6-25](#)
 IGBT test method [6-27](#)
 measurement techniques [6-26](#)
 procedures [6-17](#)
 unpacking [2-2](#)
 Installation [2-6](#)
 Instantaneous power failure [4-48](#)
 Insulation test [6-19](#)
 Integral gain [3-22](#)
 Intelligent input terminals [3-50](#), [4-13](#)
 Intelligent input wiring examples [4-13](#)
 Intelligent output terminals [3-55](#), [4-43](#)
 Intelligent terminal functions [3-50](#)
 Intelligent terminal index [4-11](#)
 Intelligent terminals [A-3](#)
 Inverter [1-18](#)
 Inverter definition [A-3](#)
 Inverter ready signal [4-61](#)
 Inverter specifications [1-6](#)
 Isolation transformer [A-4](#)

J

Jog command [4-18](#)
 Jog frequency settings [3-13](#)
 Jogging operation [A-4](#)
 Jump frequency [3-21](#), [A-4](#)

K

Keypad
 features [2-29](#), [3-3](#)
 navigation [2-31](#), [3-4](#)
 navigation, trip events [6-15](#)
 Keypad features [2-29](#)
 Keypads [1-3](#), [3-2](#)

L

LEDs [2-29](#), [3-3](#)
 Line reactor [A-4](#)
 Linear accel/decel [3-26](#)
 Logic connector [4-9](#)
 Logic output signals [4-58](#)
 Logic terminals [3-50](#), [3-55](#)
 input wiring examples [4-13](#)
 Low cooling fan speed [4-59](#)
 Low output current signal [4-60](#)

M

Main profile parameters [3-9](#)
 Maintenance procedures [6-17](#)
 Major failure signal [4-61](#)
 Megger test [6-19](#)
 ModBus mode communications [B-21](#)
 Model number convention [1-5](#)
 Momentum [A-4](#)
 Monitor mode [2-31](#), [2-35](#), [2-36](#), [3-4](#)
 Monitoring functions [3-6](#)
 Motor constants [3-66](#), [4-69](#)
 auto-tuning [4-71](#)
 manual setting of [4-74](#)
 Motor load [A-4](#)
 Motor poles [2-34](#)
 Motor selection [1-19](#)
 Motor wiring [2-26](#)
 Mounting location [2-6](#)
 Multiple motors
 configuration [4-76](#)
 Multi-speed operation [4-15](#), [4-17](#), [A-4](#)
 Multi-speed profiles [1-16](#)
 Multi-speed settings [3-13](#)
 Multi-stage position select [4-39](#)

N

Nameplate [1-5](#)
 Navigational map [2-31](#), [3-4](#)
 trip events [6-15](#)
 NEC [A-4](#)
 NEMA [A-4](#)
 NEMA compliance [2-17](#)
 NEMA rating [2-8](#)
 Network detection signal [4-57](#)
 Noise filters [5-2](#)
 AC reactor [2-5](#)
 Noise suppression [1-19](#)

O

Open-collector outputs [4-43](#), [A-4](#)
 Operational modes [3-5](#)
 Operator interfaces [1-3](#)
 Optimal accel/decel [3-23](#)
 Optional components [2-5](#)
 Options [1-2](#)
 Orientation [A-4](#)
 Output circuits [4-43](#)
 Output deviation for PID control [4-46](#)
 Output frequency [3-9](#)
 Output overload [3-36](#)
 Output terminals [2-26](#)
 Over-current trip [3-30](#)
 Overload advance notice signal [4-46](#)
 Overload restriction [3-36](#), [4-29](#)
 Over-torque signal [4-48](#)

P

P Group functions [3-69](#)
 P/PI selection [4-26](#)
 Parameter editing [2-29](#), [2-32](#)
 Parameter settings tables [C-2](#)
 Parameters [1-16](#)
 Phase loss [3-30](#)
 PID feedback second stage output [4-56](#)
 PID loop [1-19](#), [A-4](#)

- Clear integrator [4-26](#)
- Disable [4-26](#)
- error [A-3](#)
- operation [4-75](#)
- output deviation [4-46](#)
- process variable [A-4](#)
- setpoint [A-5](#)
- settings [3-22](#)

 PLC, connecting to [4-7](#)
 Poles [1-19](#)
 Poles of motor [2-34](#)
 Potentiometer [2-33](#), [4-65](#)
 Power factor [A-4](#)
 Power failure [4-48](#)
 Power failure response [3-30](#)
 Power loss [4-4](#)
 Power loss response [3-42](#)
 Power source switching [4-22](#)
 Power-on time over signal [4-51](#)
 Powerup test [2-27](#)

- observations [2-36](#)

 Powerup, unattended start [4-21](#)
 Process variable [A-4](#)
 Program mode [2-31](#), [2-36](#), [3-4](#)
 Programming device [3-2](#)
 Programming error codes [3-75](#)
 Programming error monitoring [3-8](#)
 Proportional gain [3-22](#)
 Pulse counter signals [4-42](#)
 Pulse-width modulation [4-66](#)
 PWM [A-4](#)

R

Ratings label [1-5](#)
 Reactance [A-5](#)
 Read/write copy unit [1-3](#), [3-2](#)
 Rectifier [A-5](#)
 Reduced torque [3-15](#)
 Regenerative braking [A-5](#)
 Regulation [A-5](#)
 Regulatory agency approvals [1-5](#)
 Relay alarm contacts [4-47](#)
 Remote control [4-28](#)
 Removable components [1-4](#)
 Reset function [4-24](#)
 Reset Mode [3-62](#)
 Restart Mode [3-45](#), [3-62](#)
 Retention screws [2-4](#)
 Reverse run command [4-15](#)
 Reverse torque [A-5](#)
 Reverse U-shape accel/decel [3-26](#)
 Rotor [A-5](#)
 Run command [4-15](#)
 Run mode [2-36](#), [3-5](#)
 Run signal [4-44](#)
 Running the motor [2-35](#)
 Run-time edits [3-5](#), [3-38](#), [4-23](#)
 Run-time signal [4-51](#)

S

Safety messages [i](#)
 Saturation voltage [A-5](#)
 Second motor [4-19](#)
 Second stage output, PID [4-56](#)
 Sensorless vector control [3-14](#), [3-16](#), [A-5](#)
 Serial communications [3-61](#), [B-2](#)
 Set 2nd/3rd motors [4-19](#)
 Setpoint [A-5](#)
 Sigmoid accel/decel [3-26](#)
 Single-phase power [A-5](#)
 Sinking I/O [4-7](#)
 Slip [A-5](#)
 Software lock [3-5](#), [3-38](#), [4-23](#)
 Sourcing I/O [4-7](#)
 Spare parts [6-20](#)
 Specifications

- general [1-10](#)
- logic signals [4-9](#)

 Speed control [1-14](#), [1-16](#), [4-15](#), [4-17](#)
 Speed loop gains [4-26](#)
 Speed pot [2-33](#)
 Speed servo ON [4-37](#)
 Speed/position control select [4-41](#)
 Squirrel cage [A-5](#)
 Standard functions [3-10](#)
 Start frequency [A-5](#)
 Starting contact signal [4-59](#)
 Stator [A-5](#)

Stop command [4-15](#)
 Stop Mode [3-45](#)
 Supply wiring [2-22](#)
 Switching frequency [3-44](#)
 Symbol definitions [i](#)
 System description [2-5](#)

T

Tachometer [A-5](#)
 Teaching (position) function [3-73](#)
 Technical support [1-xx](#)
 Term definitions [A-2](#)
 Terminal block [1-4](#)
 Terminal listing [4-11](#)
 Thermal overload [3-32](#)
 Thermal protection [4-25](#)
 Thermal switch [A-6](#)
 Thermal warning [4-52](#)
 Thermistor [A-6](#)
 Thermistor input [4-25](#)
 Third motor [4-19](#)
 Three-phase power [A-6](#)
 motor phase connections [1-15](#)
 Three-wire interface [4-25](#)
 Torque [1-14](#)
 Torque boost [3-17](#)
 Torque control algorithms [3-5](#), [3-14](#), [3-66](#)
 tuning [4-69](#)
 Torque control enable [4-35](#)
 Torque limit [4-30](#)
 Torque limit signal [4-51](#)
 Torque specs, terminals [2-20](#)
 Torque, definition [A-6](#)
 Transistor [A-6](#)
 Transporting the inverter [2-7](#)
 Trip events [3-8](#)
 clearing [6-5](#)
 definition [A-6](#)
 error codes [6-6](#)
 external [4-21](#)
 history [6-15](#)
 monitoring [6-5](#)
 Trip history [6-15](#)
 Trip mode [4-24](#)
 Troubleshooting tips [6-3](#)
 Two-stage accel/decel [4-20](#)

U

U Group functions [3-74](#)
 UL instructions [xii](#)
 Unattended start protection [4-21](#)
 Under-voltage signal [4-48](#)
 Under-voltage trip [3-30](#)
 Unpacking [2-2](#)
 Up/Down functions [4-28](#)
 User-selectable menu functions [3-74](#)
 U-shape accel/decel [3-26](#)

V

V/f control [3-14](#)
 V/f control setting [3-47](#)
 V/f free-setting [3-16](#)
 Variable torque [3-15](#)
 Variable-frequency drives
 introduction [1-14](#)
 Velocity profile [1-16](#)
 Ventilation [2-8](#), [2-26](#)

W

Warnings
 operating procedures [4-3](#)
 Warranty [6-29](#)
 Watt loss [A-6](#)
 Windmilling [3-18](#), [3-21](#)
 Window comparator signals [4-62](#)
 Wiring
 analog inputs [4-65](#)
 gauge [2-18](#)
 intelligent input wiring examples [4-13](#)
 logic [2-26](#)
 logic connector [4-9](#)
 output [2-26](#)
 power input [2-22](#)
 preparation [2-17](#)
 serial communications [B-3](#)
 system diagram [4-8](#)

Z

Zero-phase reactor [5-4](#)
 Zero-return functions [4-40](#)