

ACOPOSinverter P84

Variable speed drives for
synchronous motors and
asynchronous motors

0.37 (0.5 HP) to 45 KW (60 HP) / 200 - 240V
0.75 (1 HP) to 75 KW (100 HP) / 380 - 480V

User's Manual

Version: 0.20 (February 2011)
Model number: MAxxxxxxx-ENG



All information contained in this manual is current as of its creation/publication. We reserve the right to change the contents of this manual without warning. The information contained herein is believed to be accurate as of the date of publication; however, Bernecker + Rainer Industrie-Elektronik Ges.m.b.H. makes no warranty, expressed or implied, with regard to the products or the documentation contained within this book. In addition, Bernecker + Rainer Industrie-Elektronik Ges.m.b.H. shall not be liable in the event of incidental or consequential damages in connection with or resulting from the furnishing, performance, or use of these products. The software names, hardware names, and trademarks used in this document are registered by the respective companies.

Table of Contents

Manual history	4
Important information	5
Before you begin	6
Steps for setting up the drive	8
Preliminary recommendations	9
Drive ratings	11
Dimensions and weights	13
Mounting and temperature conditions	14
Mounting in a wall-mounted or floor-standing enclosure	16
Installing the graphic display terminal	18
Position of the charging LED	19
Installing option cards	20
Installing the EMC plates	22
Wiring recommendations	23
Power terminals	25
Control terminals	27
Connection diagrams	33
Safety integrated function - Connection diagrams	35
Connection diagrams	37
Use on IT system and corner grounded system	40
Electromagnetic compatibility, wiring	41
Safety integrated function - Before you begin	43
Safety integrated function - Overview	44
Safety integrated function - Description	48

Manual history

Version	Date	Comment
0.20	February 2011	Added hazard notes (chapter "Before you begin") Added section "EMC conditions for ACOPOSinverter P84" (chapter "Electromagnetic compatibility, wiring") Added chapter: "Safety integrated function - Connection diagrams" "Safety integrated function - Before you begin" "Safety integrated function - Overview" "Safety integrated function - Description"
0.12	November 2010	Adaption model numbers Status LED description added
0.11	August 2010	First edition

Important information

PLEASE NOTE

Please read these instructions carefully and examine the equipment in order to familiarize yourself with the device before installing, operating or carrying out any maintenance work on it.

The following special messages that you will come across in this document or on the device are designed to warn you about potential risks or draw your attention to information that will clarify or simplify a procedure.



The addition of this symbol to a “Danger” or “Warning” safety label indicates that there is an electrical risk that will result in injury if the instructions are not followed.



This is a safety warning symbol. It warns you of the potential risk of injury. You must comply with all safety messages that follow this symbol in order to avoid the risk of injury or death.

DANGER

DANGER indicates an imminently hazardous situation which, if not avoided, **will result in** death, serious injury or equipment damage.

WARNING

WARNING indicates a potentially hazardous situation which, if not avoided, **can result in** death, serious injury or equipment damage.

CAUTION

CAUTION indicates a potentially hazardous situation which, if not avoided, **can result in** injury or equipment damage.

PLEASE NOTE:

Only qualified personnel are authorized to carry out maintenance work on electrical equipment. B&R accepts no responsibility for the consequences of using this device. This document does not constitute an instruction manual for inexperienced personnel.

Before you begin

Read and understand these instructions before performing any procedure with this drive.

DANGER

HAZARD OF ELECTRIC SHOCK, EXPLOSION, OR ARC FLASH

- Read and understand this manual before installing or operating the ACOPOSinverter P84 drive. Installation, adjustment, repair, and maintenance must be performed by qualified personnel.
- The user is responsible for compliance with all international and national electrical code requirements with respect to grounding of all equipment.
- Many parts of this drive, including the printed circuit boards, operate at the line voltage. DO NOT TOUCH. Use only electrically insulated tools.
- DO NOT touch unshielded components or terminal strip screw connections with voltage present.
- DO NOT short across terminals PA/+ and PC/- or across the DC bus capacitors.
- Before servicing the drive:
 - Disconnect all power, including external control power that may be present.
 - Place a "DO NOT TURN ON" label on all power disconnects.
 - Lock all power disconnects in the open position.
 - WAIT 15 MINUTES to allow the DC bus capacitors to discharge. Then follow the "Bus Voltage Measurement Procedure", page 19 to verify that the DC voltage is less than 42 V. The drive LEDs are not indicators of the absence of DC bus voltage.
 - If the DC bus capacitors do not discharge completely, contact your local B&R office. Do not repair or operate the drive.
- Install and close all covers before applying power or starting and stopping the drive.

Failure to follow these instructions will result in death or serious injury.

DANGER

UNINTENDED EQUIPMENT OPERATION

- Read and understand this manual before installing or operating the ACOPOSinverter P84 drive.
- Any changes made to the parameter settings must be performed by qualified personnel.

Failure to follow these instructions will result in death or serious injury.

WARNING

DAMAGED DRIVE EQUIPMENT

Do not operate or install any drive or drive accessory that appears damaged.

Failure to follow these instructions can result in death, serious injury, or equipment damage.

Before you begin

WARNING

LOSS OF CONTROL

- The designer of any control scheme must
 - consider the potential failure modes of control paths and, for certain critical control functions,
 - provide a means to achieve a safe state during and after a path failure.Examples of critical control functions are emergency stop and overtravel stop.
- Separate or redundant control paths must be provided for critical control functions.
- System control paths may include communication links. Consideration must be given to the implications of unanticipated transmission delays or failures of the link.¹

Failure to follow these instructions can result in death, serious injury, or equipment damage.

1. For additional information, refer to NEMA ICS 1.1 (latest edition), "Safety Guidelines for the Application, Installation, and Maintenance of Solid State Control" and to NEMA ICS 7.1 (latest edition), "Safety Standards for Construction and Guide for Selection, Installation and Operation of Adjustable-Speed Drive Systems."

CAUTION

INCOMPATIBLE LINE VOLTAGE

Before turning on and configuring the drive, ensure that the line voltage is compatible with the supply voltage range shown on the drive nameplate. The drive may be damaged if the line voltage is not compatible.

Failure to follow these instructions can result in injury or equipment damage.

CAUTION

IMPROPER DRIVE OPERATION

- If the drive is not turned on for a long period, the performance of its electrolytic capacitors will be reduced.
- If it is stopped for a prolonged period, turn the drive on every two years for at least 5 hours to restore the performance of the capacitors, then check its operation. It is recommended that the drive is not connected directly to the line voltage. The voltage should be increased gradually using an adjustable AC source.

Failure to follow these instructions can result in injury and/or equipment damage.

INSTALLATION

1 Receive and inspect the drive controller

- Check that the catalog number printed on the label is the same as that on the purchase order
- Remove the ACOPOSinverter from its packaging and check that it has not been damaged in transit

2 Check the line voltage

- Check that the line voltage is compatible with the voltage range of the drive (see pages [11](#) and [12](#))

3 Mount the drive

- Mount the drive in accordance with the instructions in this document
- Install any internal and external options

4 Wire the drive

- Connect the motor, ensuring that its connections correspond to the voltage
- Connect the line supply, after making sure that the power is off
- Connect the control
- Connect the speed reference

Steps 1 to 4 must be performed with the power off.



PROGRAMMING

5 Please refer to the Programming Manual

Preliminary recommendations

Handling and storage

To protect the drive prior to installation, handle and store the device in its packaging. Ensure that the ambient conditions are acceptable.

WARNING

DAMAGED PACKAGING

If the packaging appears damaged, it can be dangerous to open it or handle it.
Take precautions against all risks when performing this operation.
Failure to follow these instructions can result in death, serious injury or equipment damage.

WARNING

DAMAGED EQUIPMENT

Do not install or operate any drive that appears damaged.
Failure to follow this instruction can result in death, serious injury or equipment damage.

Handling on installation

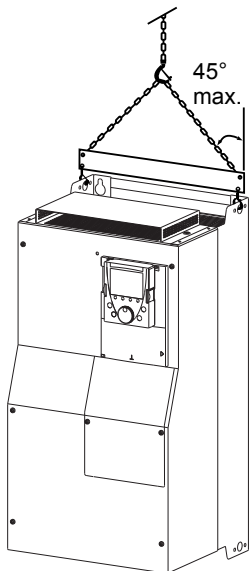

ACOPOS inverter P84 drives up to ratings 8I84T201500.01P-1 and 8I84T401850.01P-1 can be removed from their packaging and installed without a handling device.

A hoist must be used for higher ratings; for this reason, these drives all have lifting lugs. Follow the recommendations on the next page.

Preliminary recommendations

Recommendations

Read and understand the instructions in the "Programming Manual".

CAUTION

INCOMPATIBLE LINE VOLTAGE

Before turning on and configuring the drive, ensure that the line voltage is compatible with the supply voltage range shown on the drive nameplate. The drive may be damaged if the line voltage is not compatible.

Failure to follow this instruction can result in injury and/or equipment damage.

DANGER

UNINTENDED EQUIPMENT OPERATION

- Before turning on and configuring the ACOPOSinverter P84, check that the PWR (POWER REMOVAL) input is deactivated (at state 0) in order to prevent unintended operation.
- Before turning on the drive, or when exiting the configuration menus, check that the inputs assigned to the run command are deactivated (at state 0) since they can cause the motor to start immediately.

Failure to follow these instructions will result in death or serious injury.

 If the safety of personnel requires the prohibition of unwanted or unintended operation, electronic locking is performed by the ACOPOSinverter P84's Power Removal function. This function requires the use of connection diagrams conforming to standards IEC/EN 61508 capacity SIL2 and ISO 13849 PL "d". The Power Removal function takes priority over any run command.

Drive ratings

Single-phase supply voltage: 200 to 240 V 50/60 Hz

Three-phase motor 200 to 240 V

Motor		Line supply (input)					Drive (output)			ACOPOSinverter P84	
Power indicated on plate (1)		Max. line current (2)		Max. prospective line Isc	Apparent power	Max. inrush current (3)	Nominal current In (1)	Max. transient current (1) for		Catalog number	Size
		at 200 V	at 240 V					at 230 V	60 s (5) 2 s (5)		
kW	HP	A	A	kA	kVA	A	A	A	A		
0.37	0.5	6.9	5.8	5	1.4	9.6	3	4.5	4.9	8184T200075.01P-1	2
0.75	1	12	9.9	5	2.4	9.6	4.8	7.2	7.9	8184T200150.01P-1	2
1.5	2	18.2	15.7	5	3.7	9.6	8	12	13.2	8184T200220.01P-1	3
2.2	3	25.9	22.1	5	5.3	9.6	11.0	16.5	18.1	8184T200300.01P-1	3
3	-	25.9	22	5	5.3	9.6	13.7	20.6	22.6	8184T200400.01P-1(4)	3
4	5	34.9	29.9	22	7	9.6	17.5	26.3	28.8	8184T200550.01P-1(4)	4
5.5	7.5	47.3	40.1	22	9.5	23.4	27.5	41.3	45.3	8184T200750.01P-1(4)	5a

Three-phase supply voltage: 200 to 240 V 50/60 Hz

Three-phase motor 200 to 240 V

Motor		Line supply (input)					Drive (output)			ACOPOSinverter P84	
Power indicated on plate (1)		Max. line current (2)		Max. prospective line Isc	Apparent power	Max. inrush current (3)	Nominal current In (1)	Max. transient current (1) for		Catalog number	Size
		at 200 V	at 240 V					at 230 V	60 s (5) 2 s (5)		
kW	HP	A	A	kA	kVA	A	A	A	A		
0.37	0.5	3.5	3.1	5	1.3	9.6	3	4.5	4.9	8184T200037.01P-1	2
0.75	1	6.1	5.3	5	2.2	9.6	4.8	7.2	7.9	8184T200075.01P-1	2
1.5	2	11.3	9.6	5	4	9.6	8	12	13.2	8184T200150.01P-1	2
2.2	3	15	12.8	5	5.3	9.6	11	16.5	18.1	8184T200220.01P-1	3
3	-	19.3	16.4	5	6.8	9.6	13.7	20.6	22.6	8184T200300.01P-1	3
4	5	25.8	22.9	5	9.2	9.6	17.5	26.3	28.8	8184T200400.01P-1	3
5.5	7.5	35	30.8	22	12.4	23.4	27.5	41.3	45.3	8184T200550.01P-1	4
7.5	10	45	39.4	22	15.9	23.4	33	49.5	54.5	8184T200750.01P-1	5a
11	15	53.3	45.8	22	18.8	93.6	54	81	89.1	8184T201100.01P-1	5b
15	20	71.7	61.6	22	25.1	93.6	66	99	109	8184T201500.01P-1	5b
18.5	25	77	69	22	27.7	100	75	112	124	8184T201850.01P-1	6
22	30	88	80	22	32	100	88	132	145	8184T202200.01P-1	6
30	40	124	110	22	42.4	250	120	180	198	8184T203000.01P-1	7b
37	50	141	127	22	51	250	144	216	238	8184T203700.01P-1	7b
45	60	167	147	22	65	250	176	264	290	8184T204500.01P-1	7b

- (1) These power ratings and currents are given for an ambient temperature of 50°C (122°F) at the factory-set switching frequency, used in continuous operation (factory-set switching frequency of 4 kHz for 8184T200037.01P-1 to 8184T201500.01P-1 and 2.5 kHz for 8184T201850.01P-1 to 8184T204500.01P-1).
Above this factory setting, the drive will reduce the switching frequency automatically in the event of excessive temperature rise.
For continuous operation above the factory setting, derating must be applied to the nominal drive current in accordance with the curves on page 15.
- (2) Current on a line supply with the “Max. prospective line Isc” indicated and for a drive without any external options.
- (3) Peak current on power-up for the max. voltage (240 V +10%).
- (4) A line choke must be used (please refer to the catalog).
- (5) The maximum transient current for 60 s corresponds to 150% of the maximum nominal current In, followed by at most nominal current for 9 min.
The maximum transient current for 2 s corresponds to 165% of the maximum nominal current In, followed by at most nominal current for 58 sec.

 Inhibit the input phase loss fault (IPL) so that 8184T200075.01P-1 to 8184T200750.01P-1 drives can operate on a single-phase supply (see Programming Manual). If this fault is set to its factory configuration, the drive will stay locked in fault mode.

Drive ratings

Three-phase supply voltage: 380 to 480 V 50/60 Hz

Three-phase motor 380 to 480 V

Motor		Line supply (input)					Drive (output)			ACOPOSinverter P84	
Power indicated on plate (1)		Max. line current (2)		Max. prospective line Isc	Apparent power	Max. inrush current (3)	Nominal current In (1)	Max. transient current (1) for		Catalog number	Size
		at 380 V	at 480 V					60 s (4)	2 s (4)		
kW	HP	A	A	kA	kVA	A	A	A	A		
0.75	1	3.7	3	5	2.4	19.2	2.3	3.5	3.8	8I84T400075.01P-1	2
1.5	2	5.8	5.3	5	4.1	19.2	4.1	6.2	6.8	8I84T400150.01P-1	2
2.2	3	8.2	7.1	5	5.6	19.2	5.8	8.7	9.6	8I84T400220.01P-1	2
3	-	10.7	9	5	7.2	19.2	7.8	11.7	12.9	8I84T400300.01P-1	3
4	5	14.1	11.5	5	9.4	19.2	10.5	15.8	17.3	8I84T400400.01P-1	3
5.5	7.5	20.3	17	22	13.7	46.7	14.3	21.5	23.6	8I84T400550.01P-1	4
7.5	10	27	22.2	22	18.1	46.7	17.6	26.4	29	8I84T400750.01P-1	4
11	15	36.6	30	22	24.5	93.4	27.7	41.6	45.7	8I84T401100.01P-1	5a
15	20	48	39	22	32	93.4	33	49.5	54.5	8I84T401500.01P-1	5b
18.5	25	45.5	37.5	22	30.5	93.4	41	61.5	67.7	8I84T401850.01P-1	5b
22	30	50	42	22	33	75	48	72	79.2	8I84T402200.01P-1	6
30	40	66	56	22	44.7	90	66	99	109	8I84T403000.01P-1	7a
37	50	84	69	22	55.7	90	79	118.5	130	8I84T403700.01P-1	7a
45	60	104	85	22	62.7	200	94	141	155	8I84T404500.01P-1	8
55	75	120	101	22	81.8	200	116	174	191	8I84T405500.01P-1	8
75	100	167	137	22	110	200	160	240	264	8I84T407500.01P-1	8

(1) These power ratings and currents are given for an ambient temperature of 50°C (122°F) at the factory-set switching frequency, used in continuous operation (factory-set switching frequency of 4 kHz for 8I84T400075.01P-1 to 8I84T403000.01P-1 and 2.5 kHz for 8I84T403700.01P-1 to 8I84T407500.01P-1).

Above this factory setting, the drive will reduce the switching frequency automatically in the event of excessive temperature rise.

For continuous operation above the factory setting, derating must be applied to the nominal drive current in accordance with the curves on page 15.

(2) Current on a line supply with the "Max. prospective line Isc" indicated and for a drive without any external options.

(3) Peak current on power-up for the max. voltage (480 V +10%).

(4) The maximum transient current for 60 s corresponds to 150% of the maximum nominal current In, followed by at most nominal current for 9 min.

The maximum transient current for 2 s corresponds to 165% of the maximum nominal current In, followed by at most nominal current for 58 sec.

Dimensions and weights

With graphic display terminal

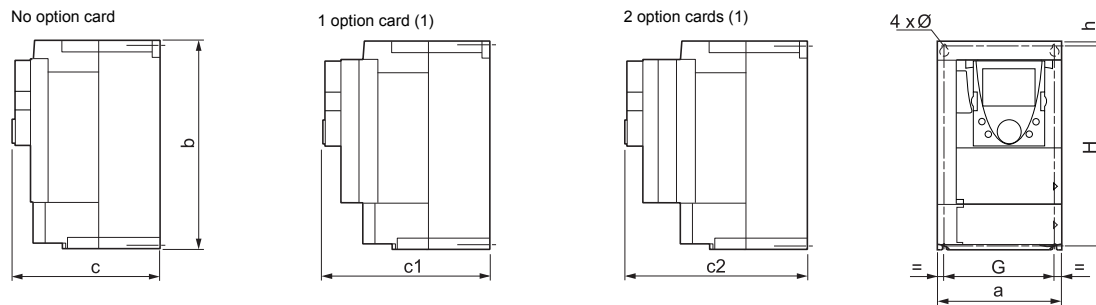

	a	b	c	c1	c2	G	H	h	Ø	For screws	Weight kg (lb.)
	mm (in.)	mm (in.)	mm (in.)	mm (in.)	mm (in.)	mm (in.)	mm (in.)	mm (in.)	mm (in.)		
8184T200037.01P-1											
8184T200075.01P-1											
8184T200150.01P-1	130	230	175	198	221	113.5	220	5	5	M4	3 (6.61)
8184T400075.01P-1	(5.12)	(9.05)	(6.89)	(7.80)	(8.70)	(4.47)	(8.66)	(0.20)	(0.20)		
8184T400150.01P-1											
8184T400220.01P-1											
8184T200220.01P-1											
8184T200300.01P-1	155	260	187	210	233	138	249	4	5	M4	4 (8.82)
8184T200400.01P-1	(6.10)	(10.23)	(7.36)	(8.27)	(9.17)	(5.43)	(9.80)	(0.16)	(0.20)		
8184T400300.01P-1											
8184T400400.01P-1											
8184T200550.01P-1	175	295	187	210	233	158	283	6	5	M4	5.5 (12.13)
8184T400550.01P-1	(6.89)	(11.61)	(7.36)	(8.27)	(9.17)	(6.22)	(11.14)	(0.24)	(0.20)		
8184T400750.01P-1											
8184T200750.01P-1	210	295	213	236	259	190	283	6	6	M5	7 (15.43)
8184T401100.01P-1	(8.27)	(11.61)	(8.39)	(9.29)	(10.20)	(7.48)	(11.14)	(0.24)	(0.24)		
8184T201100.01P-1											
8184T201500.01P-1	230	400	213	236	259	210	386	8	6	M5	9 (19.84)
8184T401500.01P-1	(9.05)	(15.75)	(8.39)	(9.29)	(10.20)	(8.26)	(15.20)	(0.31)	(0.24)		
8184T401850.01P-1											
8184T201850.01P-1	240	420	236	259	282	206	403	11	6	M5	30 (66.14)
8184T202200.01P-1	(9.45)	(16.54)	(9.29)	(10.20)	(11.10)	(8.11)	(15.87)	(0.45)	(0.24)		
8184T402200.01P-1											
8184T403000.01P-1	240	550	266	289	312	206	531.5	11	6	M5	37 (81.57)
8184T403700.01P-1	(9.45)	(21.65)	(10.47)	(11.38)	(12.28)	(8.11)	(20.93)	(0.45)	(0.24)		
8184T203000.01P-1	320	550	266	289	312	280	524	20	9	M8	37 (81.57)
8184T203700.01P-1	(12.60)	(21.65)	(10.47)	(11.38)	(12.28)	(11.02)	(20.93)	(0.79)	(0.35)		
8184T204500.01P-1											
8184T404500.01P-1	320	630	290	313	334	280	604.5	15	9	M8	45 (99.21)
8184T405500.01P-1	(12.60)	(24.80)	(11.42)	(12.32)	(13.15)	(11.02)	(23.80)	(0.59)	(0.35)		
8184T407500.01P-1											

Without graphic display terminal

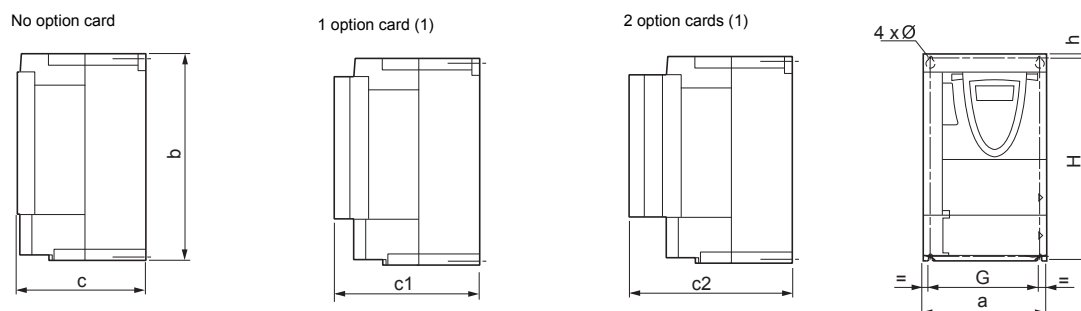

For a drive without a graphic display terminal, dimensions c, c1 and c2 in the table above are reduced by 26 mm (1.01 in.). The other dimensions are unchanged.

(1) For the addition of communication cards.

Mounting and temperature conditions

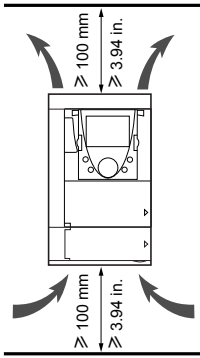

Install the drive vertically at $\pm 10^\circ$.
 Do not place it close to heating elements.
 Leave sufficient free space to ensure that the air required for cooling purposes can circulate from the bottom to the top of the unit.

Free space in front of the drive: 10 mm (0.39 in.) minimum

When IP20 protection is adequate, it is recommended that the protective cover on the top of the drive is removed as shown below.

Removing the protective cover

8184T200037.01P-1 to 8184T201500.01P-1 and
 8184T400075.01P-1 to 8184T401850.01P-1

8184T201850.01P-1 to 8184T204500.01P-1 and
 8184T402200.01P-1 to 8184T407500.01P-1

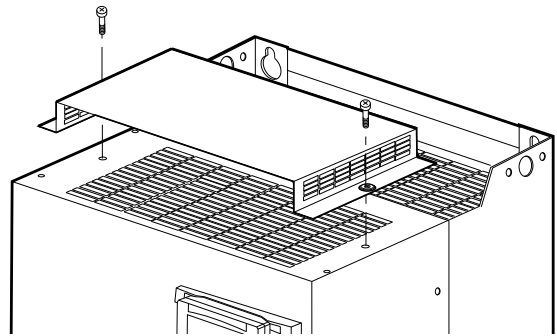
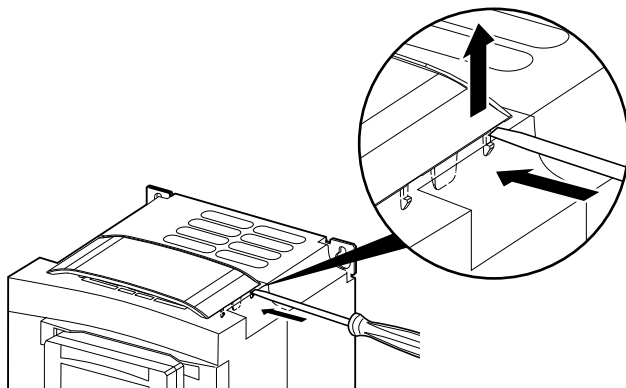

Two types of mounting are possible:

Type A mounting Free space ≥ 50 mm (≥ 1.97 in.) on each side, with protective cover fitted

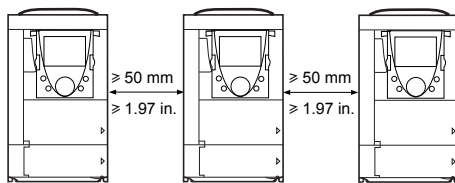

Type B mounting Drives mounted side by side, with the protective cover removed (the degree of protection becomes IP20)

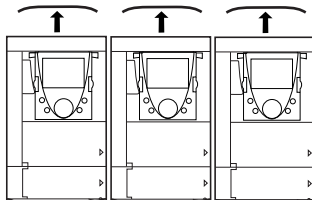

Mounting and temperature conditions

Derating curves

Derating curves for the drive current I_n as a function of the temperature, switching frequency and type of mounting.

8I84T200037.01P-1 to 8I84T201500.01P-1 and 8I84T400075.01P-1 to 8I84T401850.01P-1

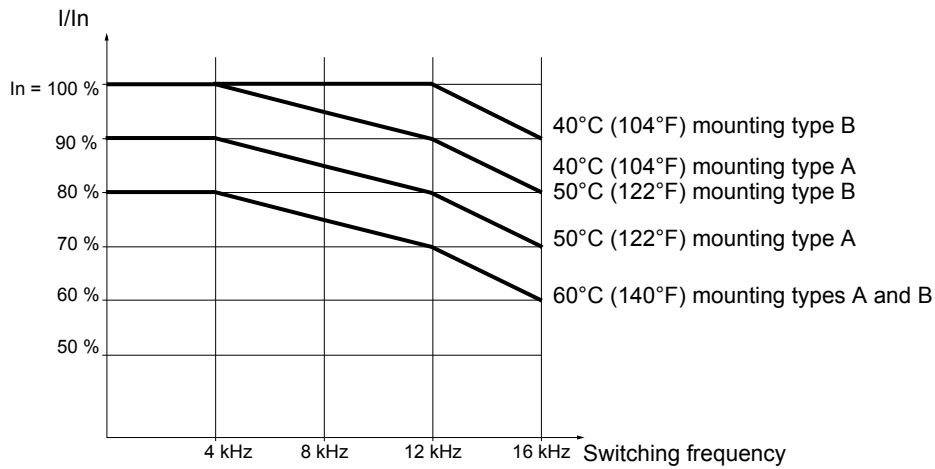

8I84T402200.01P-1 and 8I84T403000.01P-1 (1)

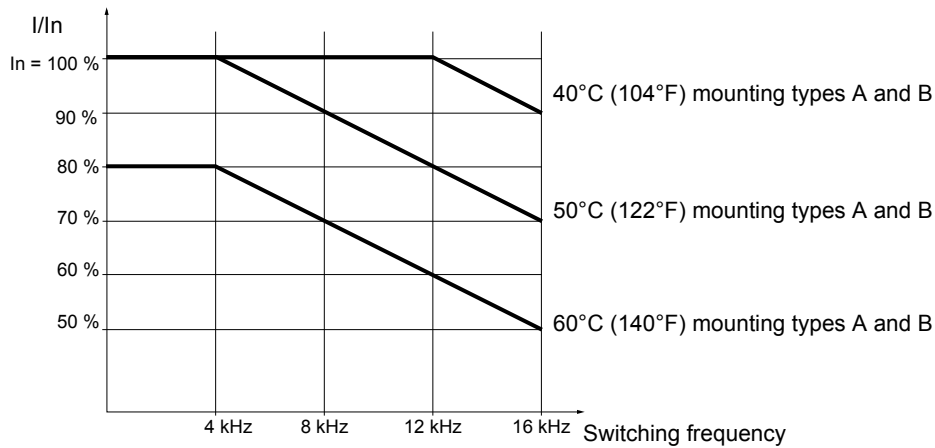

8I84T201850.01P-1 to 8I84T204500.01P-1 and 8I84T403700.01P-1 to 8I84T407500.01P-1 (1)

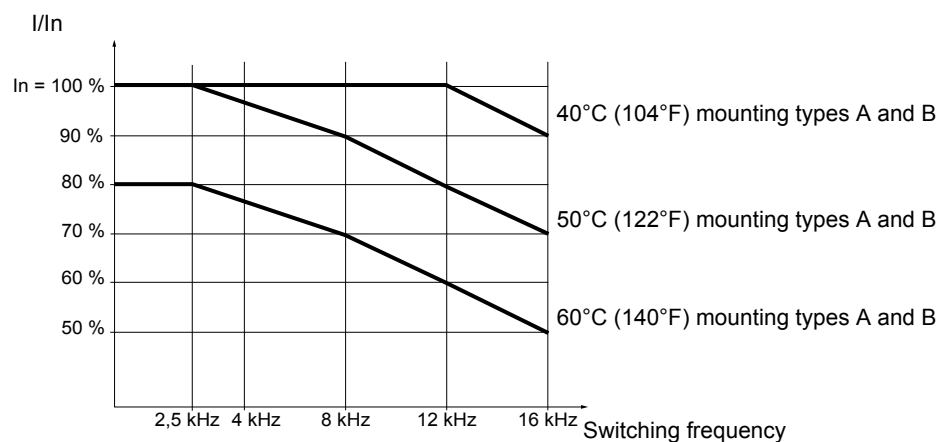

For intermediate temperatures (e.g. 55°C (131°F)), interpolate between two curves.

(1) Above 50°C (122°F), these drives must be equipped with a control card fan kit. Please refer to the catalog.

Mounting in a wall-mounted or floor-standing enclosure

Follow the mounting recommendations on the previous pages.
To ensure proper air circulation in the drive:

- Fit ventilation grilles.
- Ensure that the ventilation is adequate: if not, install a forced ventilation unit with a filter.
- Use special IP54 filters.

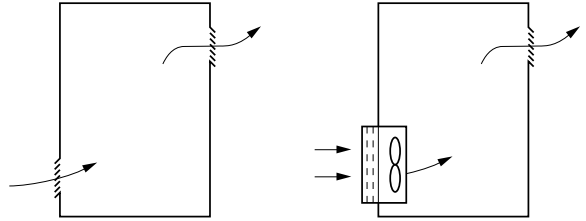

Dust and damp proof metal wall-mounted or floor-standing enclosure (IP 54 degree of protection)

The drive must be mounted in a dust and damp proof enclosure in certain environmental conditions: dust, corrosive gases, high humidity with risk of condensation and dripping water, splashing liquid, etc.

To avoid hot spots in the drive, add a fan to circulate the air inside the enclosure, catalog number 8I0XF***.300-1 (see catalog).

Mounting the drive in the enclosure

Dissipated power

These levels of power dissipation are given for operation at nominal load and for the factory-set switching frequency.

	Dissipated power (1) [W]
8I84T200037.01P-1	46
8I84T200075.01P-1	66
8I84T200150.01P-1	101
8I84T200220.01P-1	122
8I84T200300.01P-1	154
8I84T200400.01P-1	191
8I84T200550.01P-1	293
8I84T200750.01P-1	363
8I84T201100.01P-1	566
8I84T201500.01P-1	620
8I84T201850.01P-1	657
8I84T202200.01P-1	766
8I84T203000.01P-1	980
8I84T203700.01P-1	1154
8I84T204500.01P-1	1366

	Dissipated power (1) [W]
8I84T400075.01P-1	44
8I84T400150.01P-1	64
8I84T400220.01P-1	87
8I84T400300.01P-1	114
8I84T400400.01P-1	144
8I84T400550.01P-1	185
8I84T400750.01P-1	217
8I84T401100.01P-1	320
8I84T401500.01P-1	392
8I84T401850.01P-1	486
8I84T402200.01P-1	574
8I84T403000.01P-1	799
8I84T403700.01P-1	861
8I84T404500.01P-1	1060
8I84T405500.01P-1	1210
8I84T407500.01P-1	1720

(1) Add 7 W to this value for each option card added

Ensure that the flow of air in the enclosure is at least equal to the value given in the table below for each drive.

	Flow rate	
	m ³ /hour	ft ³ /min
8I84T200037.01P-1 8I84T200075.01P-1 8I84T200150.01P-1 8I84T400075.01P-1 8I84T400150.01P-1 8I84T400220.01P-1	17	10
8I84T200220.01P-1 8I84T200300.01P-1 8I84T200400.01P-1 8I84T400300.01P-1 8I84T400400.01P-1	56	33
8I84T200550.01P-1 8I84T400550.01P-1 8I84T400750.01P-1	112	66
8I84T200750.01P-1 8I84T401100.01P-1	163	96

	Flow rate	
	m ³ /hour	ft ³ /min
8I84T201100.01P-1 8I84T201500.01P-1 8I84T401500.01P-1 8I84T401850.01P-1	252	148
8I84T201850.01P-1 8I84T202200.01P-1 8I84T402200.01P-1	203	119
8I84T403000.01P-1 8I84T403700.01P-1	203	119
8I84T203000.01P-1 8I84T203700.01P-1 8I84T204500.01P-1	406	239
8I84T404500.01P-1 8I84T405500.01P-1 8I84T407500.01P-1	406	239

Mounting in a wall-mounted or floor-standing enclosure

Dust and damp proof flange mounting

This mounting is used to reduce the power dissipated in the enclosure by locating the power section outside the enclosure. This requires the use of a dust and damp proof flange-mounting kit 810MF***.300-1 (please refer to the catalog). The degree of protection for the drives mounted in this way becomes IP54.

To install the kit on the drive, please refer to the manual supplied with the kit.

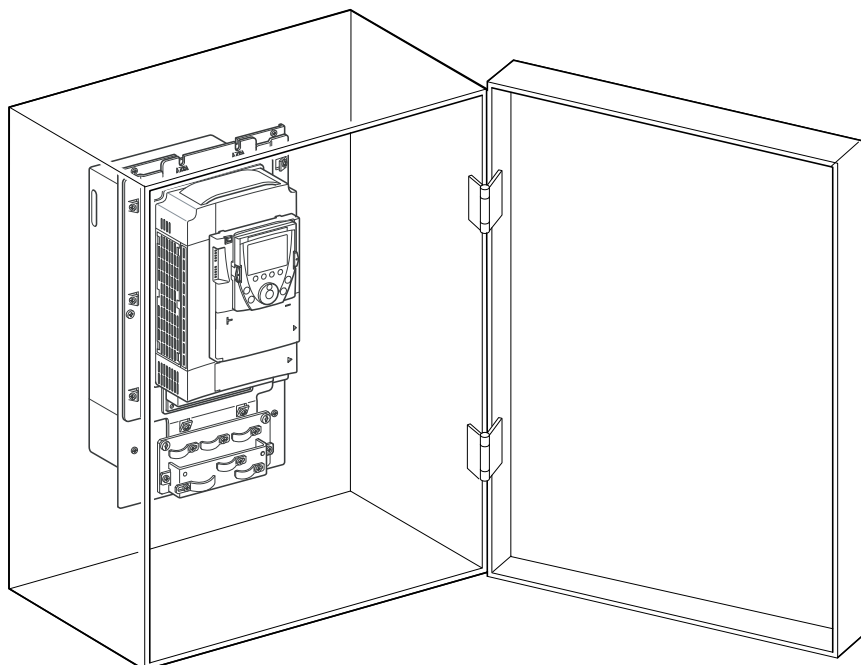

Example: 8184T400550.01P-1

Power dissipated inside the enclosure for dust and damp proof flange mounting

These levels of power dissipation are given for operation at nominal load and for the factory-set switching frequency.

	Dissipated power (1)
	W
8184T200037.01P-1	25
8184T200075.01P-1	27
8184T200150.01P-1	30
8184T200220.01P-1	38
8184T200300.01P-1	38
8184T200400.01P-1	41
8184T200550.01P-1	59
8184T200750.01P-1	67
8184T201100.01P-1	80
8184T201500.01P-1	84
8184T201850.01P-1	114
8184T202200.01P-1	124
8184T203000.01P-1	144
8184T203700.01P-1	161
8184T204500.01P-1	180

	Dissipated power (1)
	W
8184T400075.01P-1	26
8184T400150.01P-1	28
8184T400220.01P-1	30
8184T400300.01P-1	35
8184T400400.01P-1	40
8184T400550.01P-1	50
8184T400750.01P-1	55
8184T401100.01P-1	65
8184T401500.01P-1	85
8184T401850.01P-1	86
8184T402200.01P-1	110
8184T403000.01P-1	133
8184T403700.01P-1	137
8184T404500.01P-1	165
8184T405500.01P-1	178
8184T407500.01P-1	225

(1) Add 7 W to this value for each option card added

Installing the graphic display terminal

Installing the graphic display terminal on the drive

ACOPOSinverter P84 are supplied without a graphic display terminal (810XD301.300-1). This can be ordered separately. It is installed on the drive as shown below.

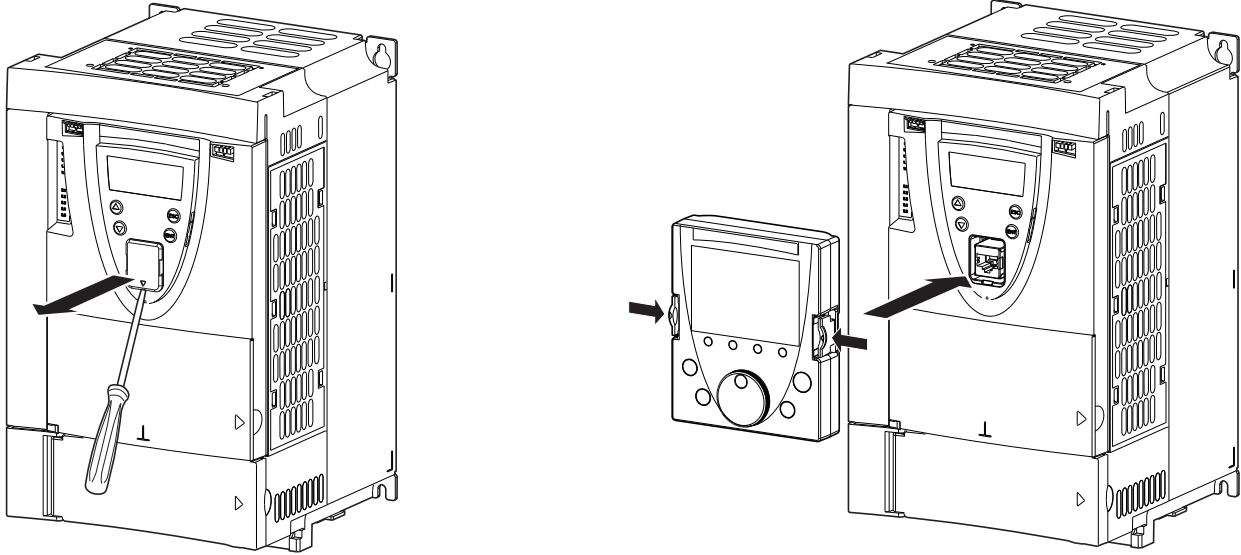

The graphic display terminal can be connected or disconnected with the power on. Before disconnecting it, drive control via the display terminal must be disabled (refer to the Programming Manual).

Position of the charging LED

Before working on the drive, turn it off, wait until the red capacitor charging LED has gone out, then measure the DC bus voltage.

Position of the capacitor charging LED

8184T200037.01P-1 to 8184T201500.01P-1 and
8184T400075.01P-1 to 8184T401850.01P-1

8184T201850.01P-1 to 8184T204500.01P-1 and
8184T402200.01P-1 to 8184T407500.01P-1

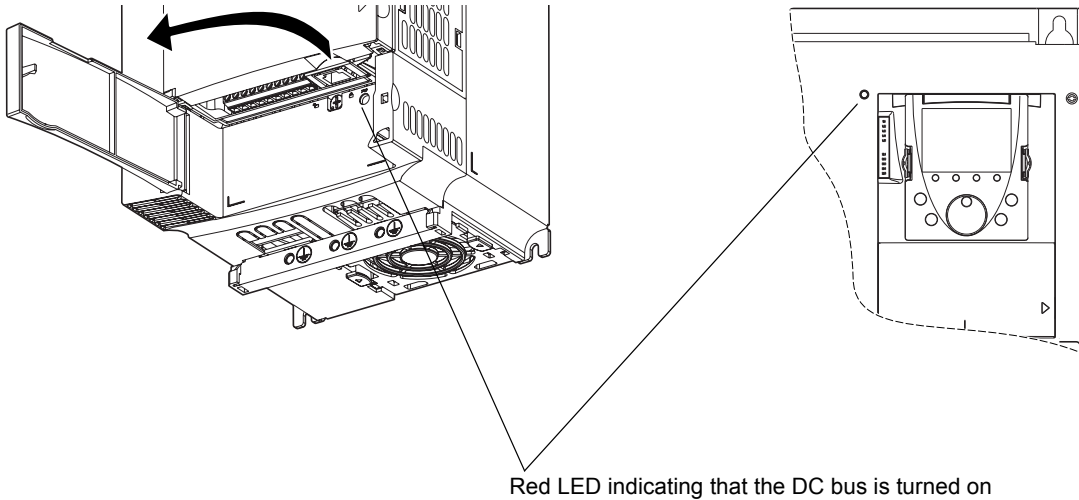

Procedure for measuring the DC bus voltage

DANGER

RISK OF ELECTRIC SHOCK

Read and understand the instructions on page 6 before performing this procedure.
Failure to follow this instruction will result in death or serious injury.

The DC bus voltage can exceed 1,000 V $\overline{\text{---}}$. Use a properly rated voltage sensing device when performing this procedure. To measure the DC bus voltage:

- 1 Disconnect the drive power supply.
- 2 Wait 15 minutes to allow the DC bus capacitors to discharge.
- 3 Measure the voltage of the DC bus between the PA/+ and PC/- terminals to check whether the voltage is less than 42 V $\overline{\text{---}}$. See page 26 for the arrangement of the power terminals.
- 4 If the DC bus capacitors have not discharged completely, contact your local B&R office (do not repair or operate the drive).

Installing option cards

These should ideally be installed once the drive is mounted and before wiring it.

Check that the red capacitor charging LED has gone out. Measure the DC bus voltage in accordance with the procedure indicated on page 19.

The option cards are installed under the drive control front panel. If the drive has a graphic display terminal, remove it, then remove the control front panel as shown below.

Removing the control front panel

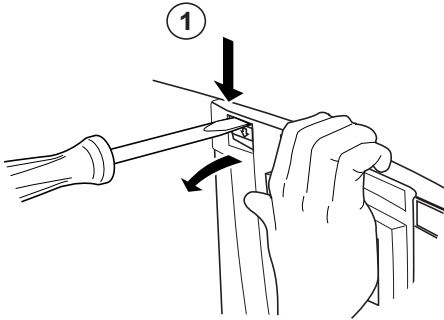

- Using a screwdriver, press down on the catch and pull to release the left-hand part of the control front panel

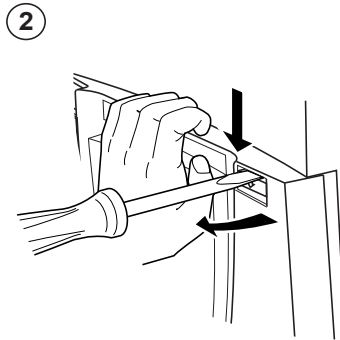

- Do the same on the right-hand side

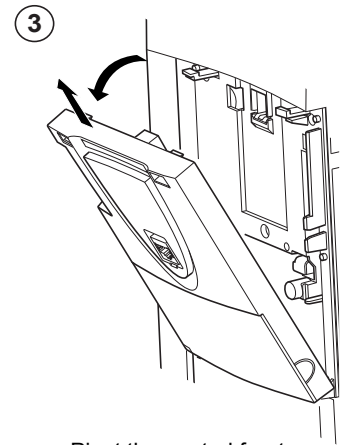

- Pivot the control front panel and remove it

Installing an encoder interface card

There is a special slot on the drive for adding an encoder interface card.

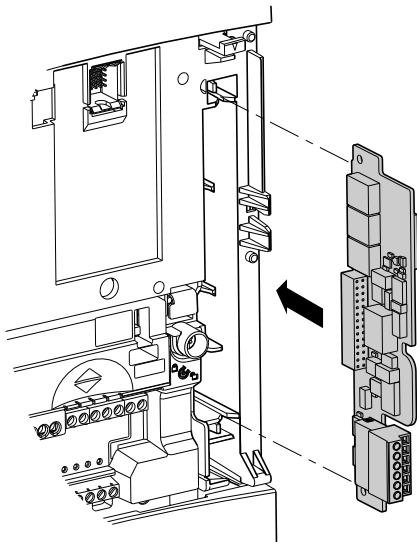

- If a communication option card has already been installed, remove it so you can access the slot for the encoder interface card.

Installing option cards

Installing a communication card

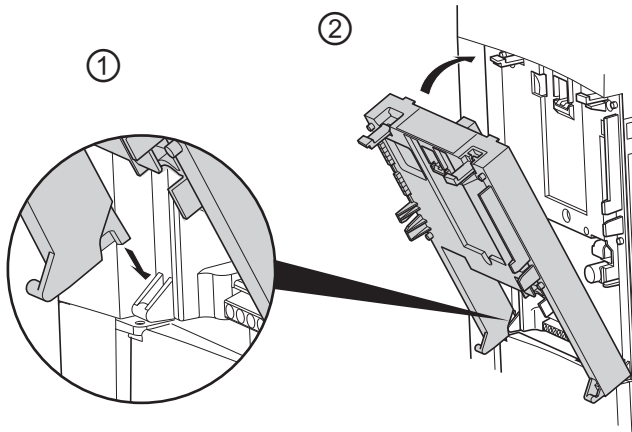

- ① Position the option card on the clasps
- ② Then pivot it until it clicks into place

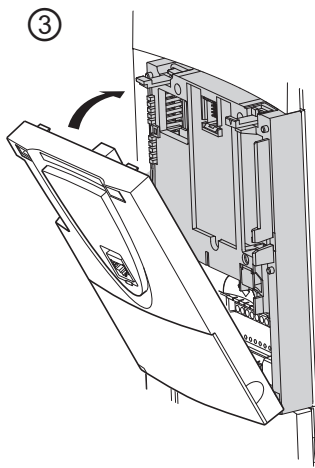

- ③ Replace the control front panel on the the option card (same procedure as for installing the option card, see ① and ②)

Installing the EMC plates

8184T200037.01P-1 to 8184T201500.01P-1 and
8184T400075.01P-1 to 8184T401850.01P-1

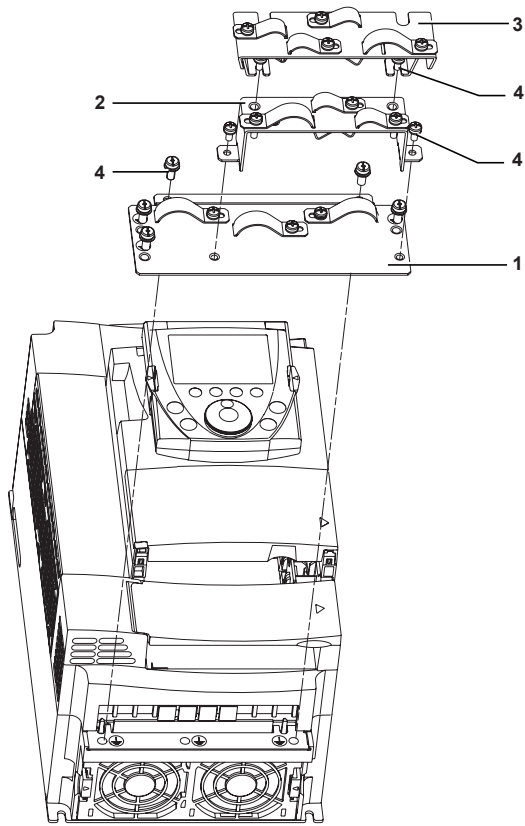

8184T201850.01P-1 to 8184T204500.01P-1 and
8184T402200.01P-1 to 8184T407500.01P-1

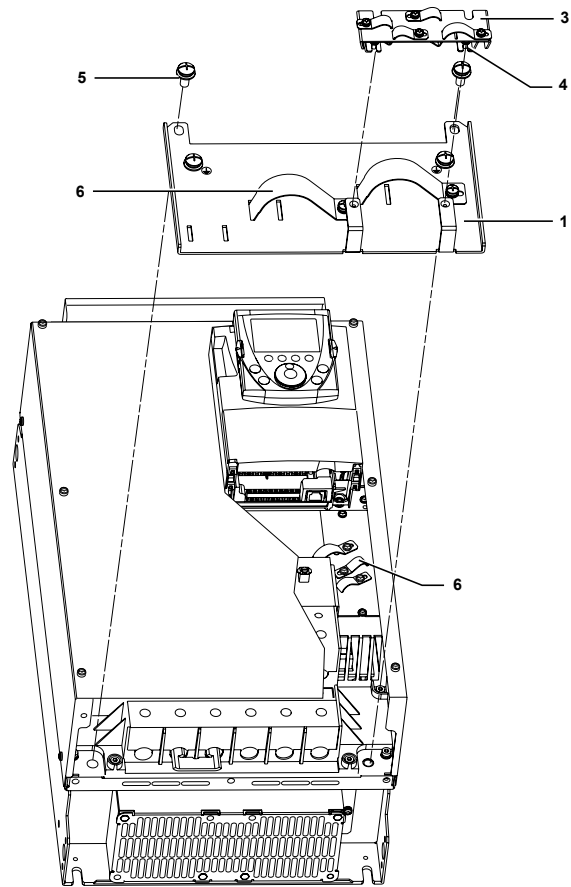

Installing the EMC clamps

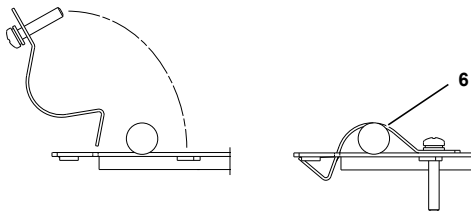

- 1 - EMC plate for connecting the power cables
- 2 - EMC plate for connecting the control cables (for 8184T200037.01P-1 to 8184T201500.01P-1 and 8184T400075.01P-1 to 8184T401850.01P-1 only)
- 3 - M4 screws (supplied)
- 4 - M8 screws (supplied)
- 5 - EMC clamps with captive screws (supplied)

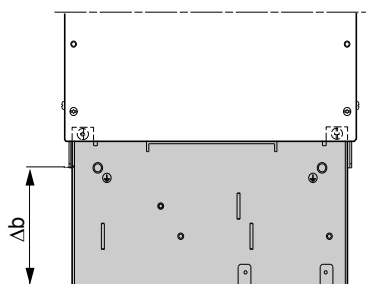

	Δb	
	mm	in.
8184T200037.01P-1 to 8184T200400.01P-1 8184T400075.01P-1 to 8184T400400.01P-1	55	2.17
8184T200550.01P-1 to 8184T201500.01P-1 8184T400550.01P-1 to 8184T401850.01P-1	65	2.56
8184T201850.01P-1 to 8184T204500.01P-1 8184T402200.01P-1 to 8184T407500.01P-1	120	4.72

Wiring recommendations

Power section

The drive must be connected to the protective ground. To comply with current regulations concerning high leakage currents (above 3.5 mA), use at least a 10 mm² (AWG 6) protective conductor or 2 protective conductors with the same cross-section as the power section AC supply conductors.

DANGER

RISK OF ELECTRIC SHOCK

Connect the device to the protective ground using the grounding point provided, as shown in the figure below. The drive panel must be connected to the protective ground before power is applied.

Failure to follow this instruction will result in death or serious injury.

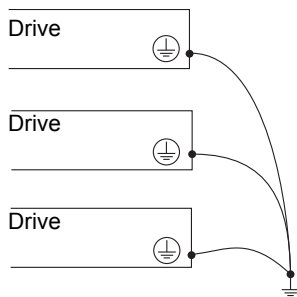

- Check whether the resistance to the protective ground is one ohm or less.
- Connect a number of drives to the protective ground, as shown in the diagram (see left). Do not wire protective grounding cables in a loop or in series.

WARNING

IMPROPER WIRING PRACTICES

- The ACOPOSinverter P84 drive will be damaged if input line voltage is applied to the output terminals (U/T1, V/T2, W/T3).
- Check the power connections before powering up the ACOPOSinverter P84 drive.
- If replacing another drive, verify that all wiring connections to the ACOPOSinverter P84 drive comply with all wiring instructions in this manual.

Failure to follow these instructions can result in death, serious injury or equipment damage.

When upstream protection by means of a “residual current device” is required by the installation standards, a type A device should be used for single-phase drives and type B for three-phase drives. Choose a suitable model integrating:

- HF current filtering
- A time delay to prevent tripping caused by the load from stray capacitance on power-up. The time delay is not possible for 30 mA devices. In this case, choose devices with immunity against nuisance tripping.

If the installation includes several drives, provide one residual current device per drive.

WARNING

INADEQUATE OVERCURRENT PROTECTION

- Overcurrent protective devices must be properly coordinated.
- The Canadian Electricity Code and the National Electrical Code require branch circuit protection. Use the fuses recommended on the drive nameplate to achieve published short-circuit current ratings.
- Do not connect the drive to a line supply whose short-circuit capacity exceeds the maximum prospective short-circuit current listed on the drive nameplate or in the tables on pages 11 and 12.

Failure to follow these instructions can result in death, serious injury or equipment damage.

Wiring recommendations

Keep the power cables separate from circuits in the installation with low-level signals (sensors, PLCs, measuring apparatus, video, telephone).

The motor cables must be at least 0.5 m (20 in.) long.

In certain situations where the motor cables have to be submerged in water, earth leakage currents can cause tripping, requiring the addition of output filters.

Do not use surge arresters or power factor correction capacitors on the variable speed drive output.

⚠ CAUTION

IMPROPER USE OF A BRAKING RESISTOR

- Only use the braking resistors recommended in our catalogs.
- Wire the thermal protection contact on the resistor so that the drive power supply is disconnected immediately in the event of a fault (refer to the manual supplied with the resistor).

Failure to follow these instructions can result in injury and/or equipment damage.

Control section

Keep the control circuits away from the power circuits. For control and speed reference circuits, we recommend using shielded twisted cables with a pitch of between 25 and 50 mm (0.98 and 1.97 in.) and connecting the shielding to ground at each end.

If using conduit, do not lay the motor, power supply and control cables in the same conduit. Keep the metal conduit containing the power supply cables at least 8 cm (3 in.) away from the metal conduit containing the control cables. Keep the non-metal conduits or cable ducts containing the power supply cables at least 31 cm (12 in.) away from the metal conduits containing the control cables. If it is necessary for control and power supply cables to cross each other, be sure they cross at right angles.

Length of motor cables

	0 m (0 ft)	10 m (32.8ft)	50 m (164 ft)	100 m (328 ft)	150 m (492 ft)	300 m (984 ft)	1000 m (3280 ft)
8I84T200037.01P-1 to 8I84T200750.01P-1 Shielded cable							
8I84T400075.01P-1 to 8I84T401500.01P-1 Unshielded cable							
8I84T201100.01P-1 to 8I84T204500.01P-1 Shielded cable							
8I84T401850.01P-1 to 8I84T407500.01P-1 Unshielded cable							

 With dv/dt filters

 With sinus filters

Note: On old-generation motors or those with poor insulation we recommend using a motor choke when the cable is more than 5 m (16.4 ft) long.

Choice of associated components:

Please refer to the catalog.

Power terminals

Access to the power terminals

8184T200037.01P-1 to 8184T201500.01P-1 and 8184T400075.01P-1 to 8184T401850.01P-1
Unlock the power part access flap and remove it as shown below.

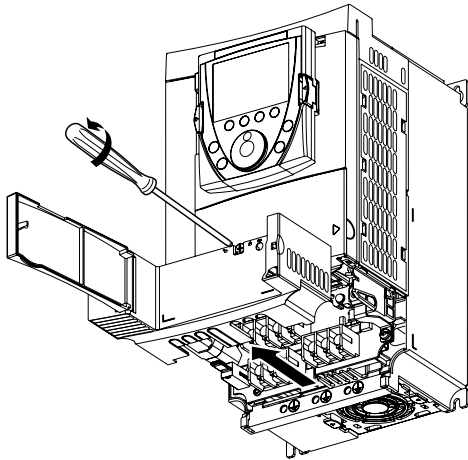

Example of 8184T200220.01P-1

8184T201850.01P-1 to 8184T204500.01P-1 and 8184T402200.01P-1 to 8184T407500.01P-1
To access the power terminals, remove the front panel as shown below.

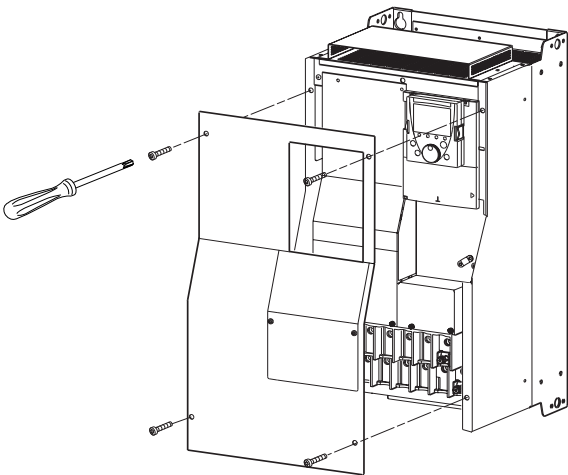

Example of 8184T407500.01P-1

Characteristics and functions of the power terminals

Terminal	Function
\perp	Protective ground connection terminal
R/L1 S/L2 T/L3	Power section AC supply
PO	DC bus + polarity
PA/+	Output to braking resistor (+ polarity)
PB	Output to braking resistor
PC/-	DC bus - polarity
U/T1 V/T2 W/T3	Outputs to the motor

 Only remove the link between PO and PA/+ if a DC choke has been added. The screws on the PO and PA/+ terminals must always be fully tightened as there is a high current flowing in the commoning link.

Power terminals

Arrangement of the power terminals

8184T200037.01P-1, 8184T200075.01P-1, 8184T200150.01P-1, 8184T200220.01P-1,
8184T200300.01P-1, 8184T200400.01P-1, 8184T400075.01P-1, 8184T400150.01P-1,
8184T400220.01P-1, 8184T400300.01P-1 and 8184T400400.01P-1

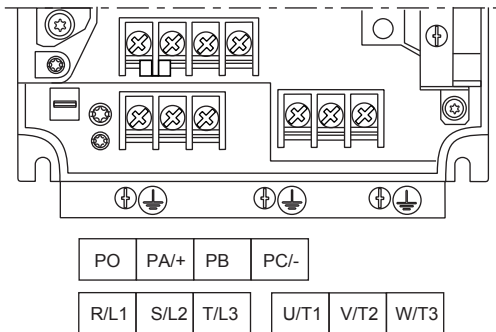

	Maximum wire size		Tightening torque
	mm ²	AWG	Nm (lb.in)
8184T200037.01P-1 8184T200075.01P-1 8184T200150.01P-1 8184T200220.01P-1 8184T200300.01P-1 8184T200400.01P-1 8184T400075.01P-1 8184T400150.01P-1 8184T400220.01P-1 8184T400300.01P-1 8184T400400.01P-1	4	10	1.4 (12.3)

8184T200550.01P-1, 8184T200750.01P-1, 8184T201100.01P-1, 8184T201500.01P-1,
8184T400550.01P-1, 8184T400750.01P-1, 8184T401100.01P-1, 8184T401500.01P-1 and
8184T401850.01P-1

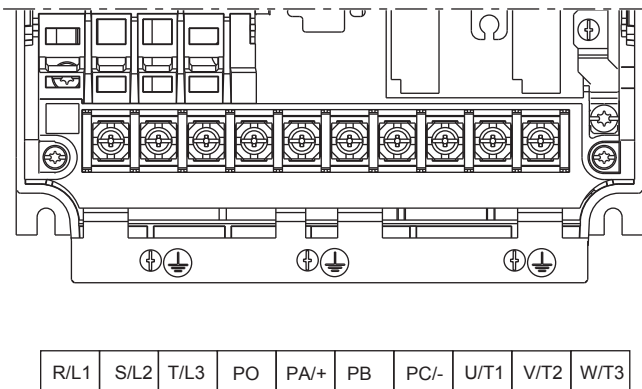

	Maximum wire size		Tightening torque
	mm ²	AWG	Nm (lb.in)
8184T200550.01P-1 8184T400550.01P-1 8184T400750.01P-1	6	8	3 (26.5)
8184T200750.01P-1 8184T401100.01P-1	16	4	3 (26.5)
8184T201100.01P-1 8184T201500.01P-1 8184T401500.01P-1 8184T401850.01P-1	35	2	5.4 (47.7)

8184T201850.01P-1, 8184T202200.01P-1, 8184T203000.01P-1, 8184T203700.01P-1,
8184T204500.01P-1, 8184T402200.01P-1, 8184T403000.01P-1, 8184T403700.01P-1,
8184T404500.01P-1, 8184T405500.01P-1 and 8184T407500.01P-1

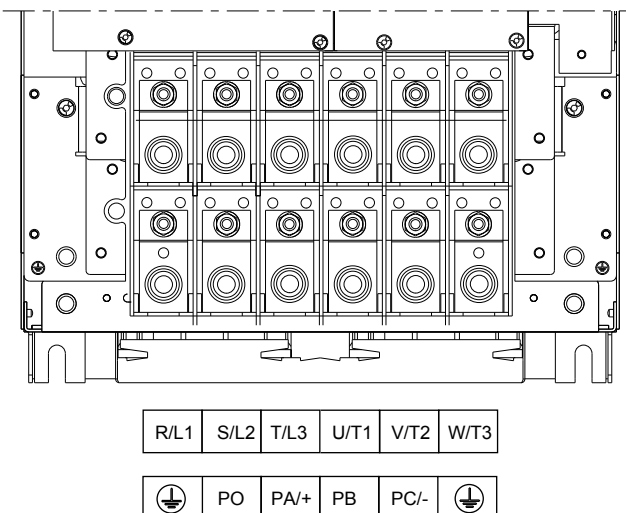

	Maximum wire size		Tightening torque
	mm ²	AWG	Nm (lb.in)
8184T201850.01P-1 8184T202200.01P-1 8184T402200.01P-1 8184T403000.01P-1 8184T403700.01P-1	50	1/0	12 (102)
8184T203000.01P-1 8184T203700.01P-1 8184T204500.01P-1 8184T404500.01P-1 8184T405500.01P-1 8184T407500.01P-1	150	300	41 (360)

Control terminals

Access to the control terminals

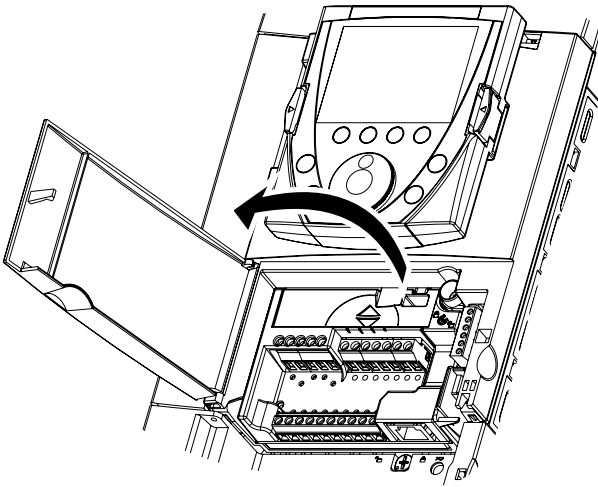

To access the control terminals, open the cover on the control front panel.

Removing the terminal card

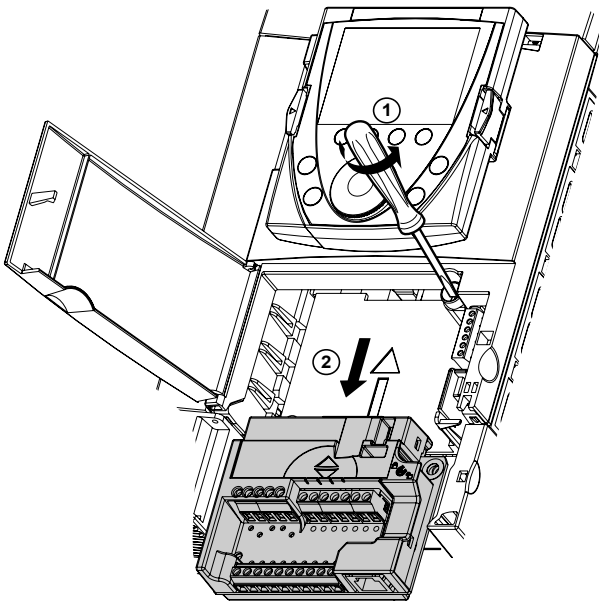

To make it easier to wire the drive control section, the control terminal card can be removed.

- ① Undo the screw until the spring is fully extended
- ② Remove the card by sliding it downwards

⚠ CAUTION

IMPROPERLY SECURED TERMINAL CARD

When replacing the control terminal card, it is essential to fully tighten the captive screw.

Failure to follow this instruction can result in injury and/or equipment damage.

Arrangement of the control terminals

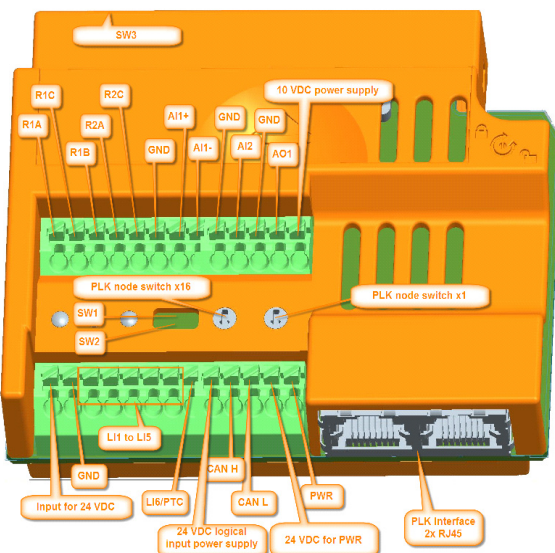

Maximum wire size:
1.5 mm² - AWG 16

Control terminals

Characteristics and functions of the control terminals

Terminal	Function	Electrical characteristics									
R1A R1C R1B	Common point C/O contact (R1C) of programmable relay R1	<ul style="list-style-type: none"> Minimum switching capacity: 3 mA for 24 V $\overline{\text{---}}$ Maximum switching capacity on resistive load: 2 A for 250 V \sim or 30 V $\overline{\text{---}}$ 									
R2A R2C	N/O contact of R2 programmable relay	<ul style="list-style-type: none"> Maximum switching current on inductive load ($\cos \varphi = 0.4$ L/R = 7 ms): 1.5 A for 250 V \sim or 30 V $\overline{\text{---}}$ Reaction time: 7 ms \pm 0.5 ms Service life: 100,000 operations at max. switching power 									
GND	Analog I/O common	0V									
AI1+ AI1 -	Differential analog input AI1	<ul style="list-style-type: none"> -10 to +10 V $\overline{\text{---}}$ (max. safe voltage 24 V) Reaction time: 2 ms \pm 0.5 ms, 11-bit resolution + 1 sign bit Accuracy TBD for $\Delta\theta = 60^\circ\text{C}$ (140°F), linearity \pm 0.15% of max. value 									
GND	Analog I/O common	0V									
AI2	Depending on software configuration: Analog voltage input or Analog current input	<ul style="list-style-type: none"> Analog input 0 to +10 V $\overline{\text{---}}$ (max. safe voltage 24 V), impedance 30 kΩ or <ul style="list-style-type: none"> Analog input X - Y mA, X and Y can be programmed from 0 to 20 mA Impedance 250 Ω Reaction time: 2 ms \pm 0.5 ms 11-bit resolution, accuracy TBD for $\Delta\theta = 60^\circ\text{C}$ (140°F), linearity \pm 0.15% of max. value 									
GND	Analog I/O common	0V									
AO1	Depending on software configuration: Analog voltage output or Analog current output or Logic output	<ul style="list-style-type: none"> Analog output 0 to +10 V $\overline{\text{---}}$, load impedance greater than 50 kΩ or <ul style="list-style-type: none"> Analog output X - Y mA, X and Y can be programmed from 0 to 20 mA Max. load impedance 500 Ω 10-bit resolution, reaction time: 2 ms \pm 0.5 ms Accuracy TBD for $\Delta\theta = 60^\circ\text{C}$ (140°F), linearity \pm 0.2% of max. value or <ul style="list-style-type: none"> logic output : 0 to +10 V or 0 to 20 mA. 									
10 VDC power supply	+ 10 V $\overline{\text{---}}$ power supply for reference potentiometer 1 to 10 k Ω	<ul style="list-style-type: none"> +10 V $\overline{\text{---}}$ (10.5 V \pm 0.5V) 10 mA max. 									
Input for 24 VDC	Input for external +24V $\overline{\text{---}}$ control power supply	<ul style="list-style-type: none"> +24 V $\overline{\text{---}}$ (min. 19 V, max. 30 V) Power 30 Watts 									
GND	Logic input common and 0V of P24 external power supply	0V									
L11 L12 L13 L14 L15	Programmable logic inputs	<ul style="list-style-type: none"> +24 V $\overline{\text{---}}$ (max. 30 V) Impedance TBD kΩ Reaction time: 2 ms \pm 0.5 ms <table border="1" style="margin-left: auto; margin-right: auto;"> <thead> <tr> <th></th> <th>State 0</th> <th>State 1</th> </tr> </thead> <tbody> <tr> <td>Sink (factory setting)</td> <td>< 5 V $\overline{\text{---}}$</td> <td>> 11 V $\overline{\text{---}}$</td> </tr> <tr> <td>Source Int or Ext</td> <td>> 16 V $\overline{\text{---}}$</td> <td>< 10 V $\overline{\text{---}}$</td> </tr> </tbody> </table>		State 0	State 1	Sink (factory setting)	< 5 V $\overline{\text{---}}$	> 11 V $\overline{\text{---}}$	Source Int or Ext	> 16 V $\overline{\text{---}}$	< 10 V $\overline{\text{---}}$
	State 0	State 1									
Sink (factory setting)	< 5 V $\overline{\text{---}}$	> 11 V $\overline{\text{---}}$									
Source Int or Ext	> 16 V $\overline{\text{---}}$	< 10 V $\overline{\text{---}}$									
L16	Depending on the position of switch SW1: - Programmable logic input or - Input for PTC probes	SW1 in right position \rightarrow LI: (factory setting) <ul style="list-style-type: none"> Same characteristics as logic inputs L11 to L15 or SW1 in left position \rightarrow PTC: <ul style="list-style-type: none"> Trip threshold 3 kΩ, reset threshold 1.8 kΩ Short-circuit detection threshold < 50Ω 									
24 VDC logical input power supply	Logic input power supply Attention: Only switch SW3 with the power off.	SW3 in right position (Sink) or left position (Source Int) <ul style="list-style-type: none"> +24 V $\overline{\text{---}}$ power supply (min. 21 V, max. 27 V), protected against short-circuits and overloads Max. current available for customers TBD mA SW3 in middle position (Source Ext) <ul style="list-style-type: none"> Input for external +24 V $\overline{\text{---}}$ power supply for the logic inputs 									
24 VDC for PWR	24 VDC power supply for Power Removal safety function input										
PWR	Power Removal safety function input When PWR is not connected to the 24V, the motor cannot be started (compliance with functional safety standards IEC/EN 61508 capacity SIL2 and ISO 13849 PL "d".)	<ul style="list-style-type: none"> 24 V $\overline{\text{---}}$ power supply (max. 30 V) Impedance TBD kΩ State 0 if < 2 V, state 1 if > 17 V Reaction time: 10 ms 									

Control terminals

LED status

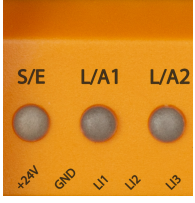
Figure	LED	Color	Status	Description
	S/E ¹	Green / red		Status/Error LED.
	L/A1	Green	On	A link to the remote station has been established.
			Blinking	A link to the remote station has been established. The LED blinks when Ethernet activity is present on the bus.
	L/A2	Green	On	A link to the remote station has been established.
			Blinking	A link to the remote station has been established. The LED blinks when Ethernet activity is present on the bus.

1. The Status/Error LED is a green/red dual LED.

The status/error LED is a green/red dual LED. The color green (status) is superimposed on the color red (error).

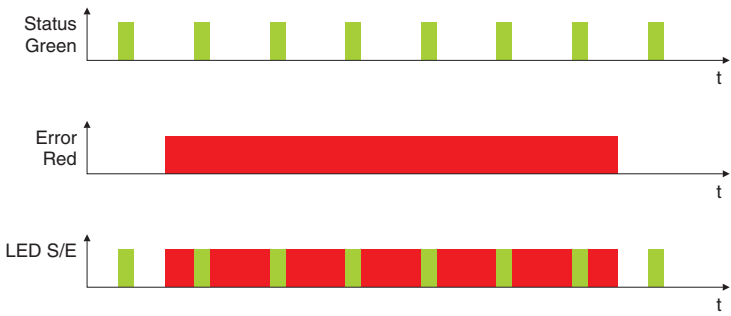
Red - error	Description
On	<p>The POWERLINK interface has encountered an error (failed Ethernet frames, increased number of collisions on the network, etc.). If an error occurs in the following states, then the green LED blinks over the red LED:</p> <ul style="list-style-type: none"> • BASIC_ETHERNET • PRE_OPERATIONAL_1 • PRE_OPERATIONAL_2 • READY_TO_OPERATE 

Green - status	Description
Off NOT_ACTIVE	The bus is monitored for POWERLINK frames. If a frame is not received within the configured time window (timeout), the ACOPOSinverter P84 goes directly into BASIC_ETHERNET status (flickering). If, however, POWERLINK communication is detected during this time, the CN goes directly into the PRE_OPERATIONAL_1 status (single flash).
Flickering green (approx. 10 Hz) BASIC_ETHERNET	The ACOPOSinverter P84 is in BASIC_ETHERNET status, and is operated purely as an Ethernet TCP/IP device. If POWERLINK communication is detected while in this status, the CN goes into the PRE_OPERATIONAL_1 state (single flash). A lit red LED in this state indicates manager failure.
Single flash (approx. 1 Hz) PRE_OPERATIONAL_1	The ACOPOSinverter P84 status is PRE_OPERATIONAL_1. The CN waits until it receives an SoC frame and then switches to PRE_OPERATIONAL_2 status (double flash). A lit red LED in this state indicates manager failure.
Double flash (approx. 1 Hz) PRE_OPERATIONAL_2	The ACOPOSinverter P84 status is PRE_OPERATIONAL_2. In this status the CN is normally configured by the manager. After this, a command changes the status to READY_TO_OPERATE (triple flash). A lit red LED in this state indicates manager failure.
Triple flash (approx. 1 Hz) READY_TO_OPERATE	The ACOPOSinverter P84 status is READY_TO_OPERATE. The configuration of the CN is complete. Normal cyclic and asynchronous communication. The PDO data sent corresponds to the PDO mapping used. However, cyclic data is not yet evaluated. A lit red LED in this state indicates manager failure.
On - OPERATIONAL	The ACOPOSinverter P84 status is OPERATIONAL.
Blinking (approx. 2.5 Hz) STOPPED	The ACOPOSinverter P84 status is STOPPED. No output data is produced and no input data is received. Only the appropriate command from the manager can enter or leave this state.

Control terminals

Station number

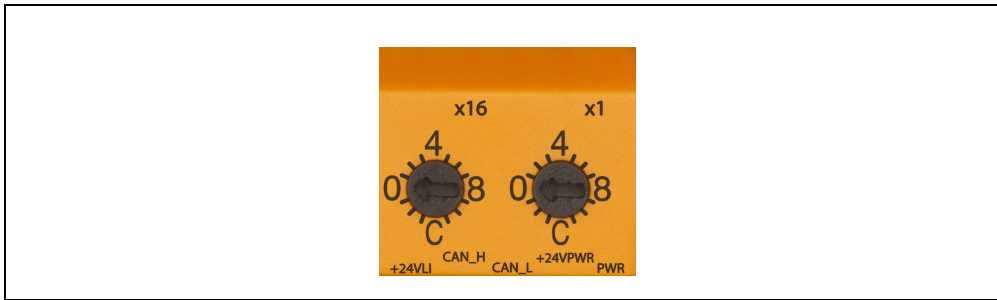

The station number for the POWERLINK station is set using the two number switches. Station numbers are permitted between \$01 and \$EF.

Switch position	Description
\$00	Reserved, switch position is not permitted.
\$01 - \$EF	Station number for POWERLINK station. Operation as controlled node.
\$F0 - \$FF	Reserved, switch position is not permitted.

System failure error codes

Incorrect configuration or defective hardware can cause a system failure error. The error is displayed via the red error LED using four switch-on phases. The switch-on phases are either 150 ms or 600 ms long. Error code outputs are repeated cyclically after 2 seconds.

Legend: • ... 150 ms
 - ... 600 ms
 brake ... 2 s delay

Error description	Error code displayed by red status LED
RAM Error	• • • - brake • • • - brake
Bus Error (internal interface defect)	- • • • brake - • • • brake

POWERLINK interface

POWERLINK 1 and POWERLINK 2

Interface	Pin assignments	
	Pin	Ethernet
Application interface POWERLINK  Shielded RJ45 port	1	RxD Receive Data
	2	RxD\ Receive Data\ Termination
	3	TxD Transmit Data
	4	Termination
	5	Termination
	6	TxD\ Transmit Data\ Termination
	7	Termination
	8	Termination

Option terminals

Encoder interface card terminals

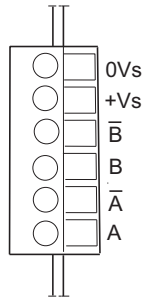

Maximum wire size:
1.5 mm² - AWG 16

Max. tightening torque:
0.25 Nm - 2.21 lb.in

Characteristics and functions of the terminals

Encoder interface cards with RS422-compatible differential outputs

Terminals	Function	Electrical characteristics	
		8I0AC123.300-1	8I0AC123.301-1
+Vs 0Vs	Power supply for encoder	<ul style="list-style-type: none"> 5 V \pm (max. 5.5 V) protected against short-circuits and overloads Max. current 200 mA 	<ul style="list-style-type: none"> 15 V \pm (max. 16 V) protected against short-circuits and overloads Max. current 175 mA
A, /A B, /B	Incremental logic inputs	<ul style="list-style-type: none"> Max. resolution: 5,000 points/rev Max. frequency: 300 kHz 	

Encoder interface cards with open collector outputs

Terminals	Function	Electrical characteristics	
		8I0AC123.302-1	8I0AC123.303-1
+Vs 0Vs	Power supply for encoder	<ul style="list-style-type: none"> 12 V \pm (max. 13 V) protected against short-circuits and overloads Max. current 175 mA 	<ul style="list-style-type: none"> 15 V \pm (max. 16 V) protected against short-circuits and overloads Max. current 175 mA
A, /A B, /B	Incremental logic inputs	<ul style="list-style-type: none"> Max. resolution: 5,000 points/rev Max. frequency: 300 kHz 	

Encoder interface cards with push-pull outputs

Terminals	Function	Electrical characteristics		
		8I0AC123.304-1	8I0AC123.305-1	8I0AC123.306-1
+Vs 0Vs	Power supply for encoder	<ul style="list-style-type: none"> 12 V \pm (max. 13 V) protected against short-circuits and overloads Max. current 175 mA 	<ul style="list-style-type: none"> 15 V \pm (max. 16 V) protected against short-circuits and overloads Max. current 175 mA 	<ul style="list-style-type: none"> 24V \pm (min. 20V, max. 30V) protected against short-circuits and overloads Max. current 100 mA
A, /A B, /B	Incremental logic inputs	<ul style="list-style-type: none"> Max. resolution: 5,000 points/rev Max. frequency: 300 kHz 		

Option terminals

Wiring the encoder

Use a shielded cable containing 3 twisted pairs with a pitch of between 25 and 50 mm (0.98 in. and 1.97 in.). Connect the shielding to ground at both ends.

The minimum cross-section of the conductors must comply with the data in the tables below, in order to limit line voltage drop:

Max. encoder cable length	8I0AC123.300-1, 8I0AC123.301-1			8I0AC123.302-1 to 8I0AC123.306-1		
	Max. consumption current of encoder	Minimum cross-section of conductors		Max. consumption current of encoder	Minimum cross-section of conductors	
10 m 32.8 ft	100 mA	0.2 mm ²	AWG 24	100 mA	0.2 mm ²	AWG 24
	200 mA	0.2 mm ²	AWG 24	200 mA	0.2 mm ²	AWG 24
50 m 164 ft	100 mA	0.5 mm ²	AWG 20	100 mA	0.5 mm ²	AWG 20
	200 mA	0.75 mm ²	AWG 18	200 mA	0.75 mm ²	AWG 18
100 m 328 ft	100 mA	0.75 mm ²	AWG 18	100 mA	0.75 mm ²	AWG 18
	200 mA	1.5 mm ²	AWG 15	200 mA	1.5 mm ²	AWG 15
200 m 656 ft	-	-	-	100 mA	0.5 mm ²	AWG 20
	-	-	-	200 mA	1.5 mm ²	AWG 15
300 m 984 ft	-	-	-	100 mA	0.75 mm ²	AWG 18
	-	-	-	200 mA	1.5 mm ²	AWG 15

Connection diagrams

Connection diagrams conforming to standards IEC/EN 61508 capacity SIL1, stopping category 0 in accordance with standard IEC/EN 60204-1

Single-phase power supply (8I84T200075.01P-1 to 8I84T200750.01P-1)

Diagram with line contactor

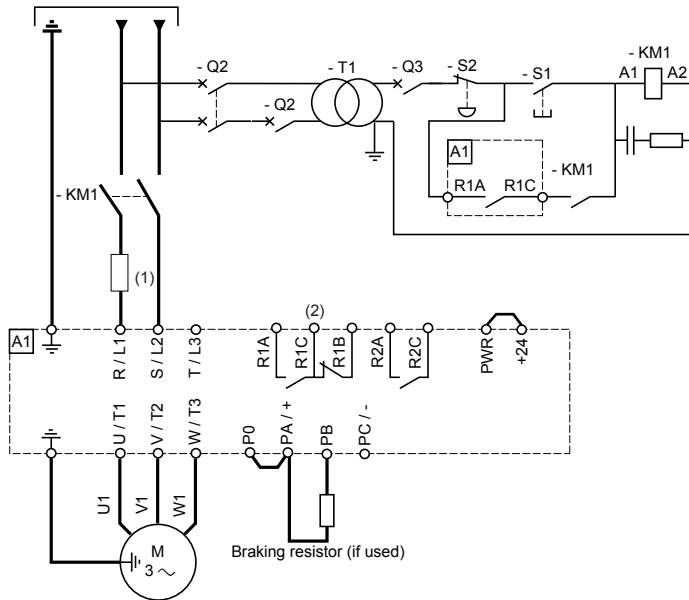
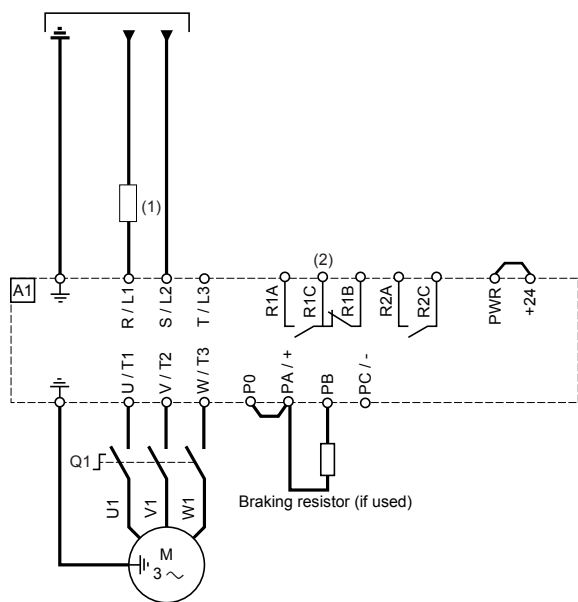



Diagram with switch disconnect



- (1) Line choke, if required (compulsory for 8I84T200400.01P-1 to 8I84T200750.01P-1 drives)
- (2) Fault relay contacts for remote signaling of drive status

 Inhibit the input phase loss fault (IPL) so that 8I84T200075.01P-1 to 8I84T200750.01P-1 drives can operate on a single-phase supply (see Programming Manual). If this fault is set to its factory configuration, the drive will stay locked in fault mode.

Note: Install interference suppressors on all inductive circuits near the drive or connected to the same circuit (relays, contactors, solenoid valves, etc).

Choice of associated components:
Please refer to the catalog.

Connection diagrams

Connection diagrams conforming to standards IEC/EN 61508 capacity SIL1, stopping category 0 in accordance with standard IEC/EN 60204-1

Three-phase power supply

Diagram with line contactor

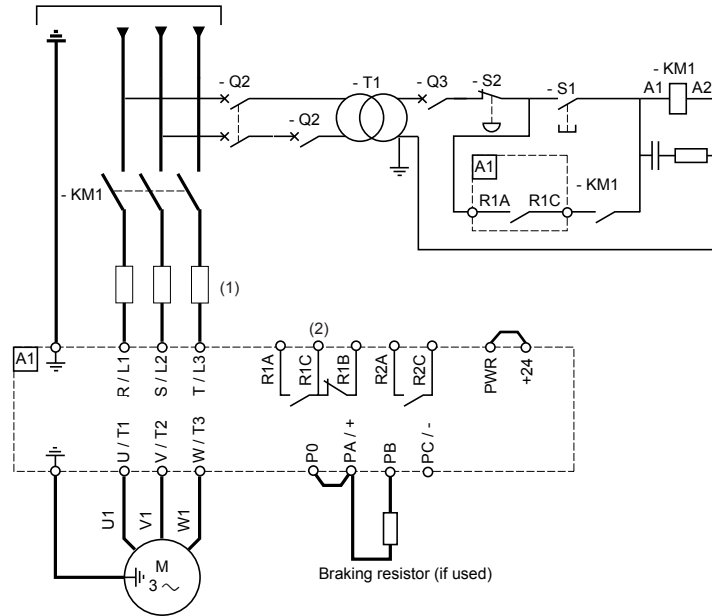
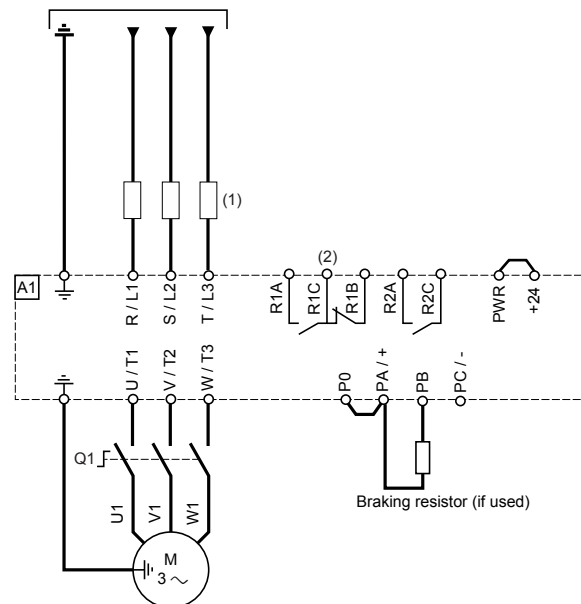

Diagram with switch disconnect



(1) Line choke (if required)

(2) Fault relay contacts for remote signaling of drive status

Note: Install interference suppressors on all inductive circuits near the drive or coupled to the same circuit (relays, contactors, solenoid valves, etc).

Choice of associated components:

Please refer to the catalog.

Safety integrated function - Connection diagrams

Connection diagram conforming to standards IEC/EN 61508 capacity SIL2 and ISO 13849 PL "d", stopping category 0 in accordance with standard IEC/EN 60204-1

Functional safety certification pending

This connection diagram is suitable for use with machines with a short freewheel stop time (machines with low inertia or high resistive torque). When the stop request is activated, the motor power supply is cut immediately and it stops in accordance with category 0 of standard IEC/EN 60204-1.

 **This diagram must be used for hoisting applications if a mechanical brake is controlled by the ACOPOSinverter P84.**

A contact on the Preventa XPS AC module must be inserted in the brake control circuit to engage it safely when the Power Removal safety function is activated.

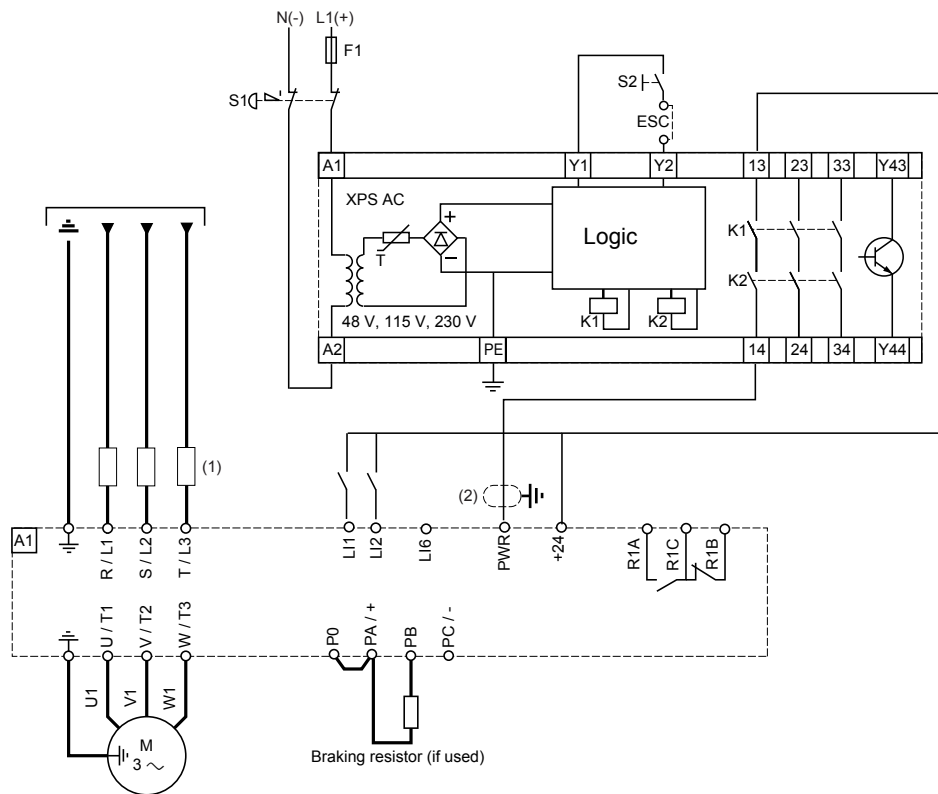

(1) Line choke (if used)

(2) Standardized coaxial cable, type RG174/U according to MIL-C17 or KX3B according to NF C 93-550, external diameter 2.54 mm, maximum length 15 m. The cable shielding must be earthed.

- Standard IEC/EN 61508 capacity SIL2 and ISO 13849 PL "d" requires the use of a dual-contact stop button (S1).
- S1 is used to activate the Power Removal safety function.
- S2 is used to initialize the Preventa module when powering up or after an emergency stop. ESC enables the use of other initialization conditions for the module.
- One Preventa module can be used for the Power Removal safety function on several ACOPOSinverter P84 drives.
- A logic output on the Preventa module can be used to indicate reliably that the drive is operating in safe conditions.

Note:

For preventive maintenance, the Power Removal function must be activated at least once a year.

The drive power supply must be turned off and then on again before carrying out this preventive maintenance.

The drive logic output signals cannot be considered as safety-type signals.

Install interference suppressors on all inductive circuits near the drive or coupled to the same circuit (relays, contactors, solenoid valves, etc).

Safety integrated function - Connection diagrams

Connection diagram conforming to standards IEC/EN 61508 capacity SIL2 and ISO 13849 PL "d", stopping category 1 in accordance with standard IEC/EN 60204-1

Functional safety certification pending

This connection diagram is suitable for use with machines with a long freewheel stop time (machines with high inertia or low resistive torque).

 **This diagram must not be used for hoisting applications.**

When the stop request is activated, deceleration of the motor, controlled by the drive, is requested first. Then, after a time delay corresponding to the deceleration time, the Power Removal safety function is activated.

Example:

- 2-wire control
- LI1 assigned to forward
- LI2 assigned to reverse

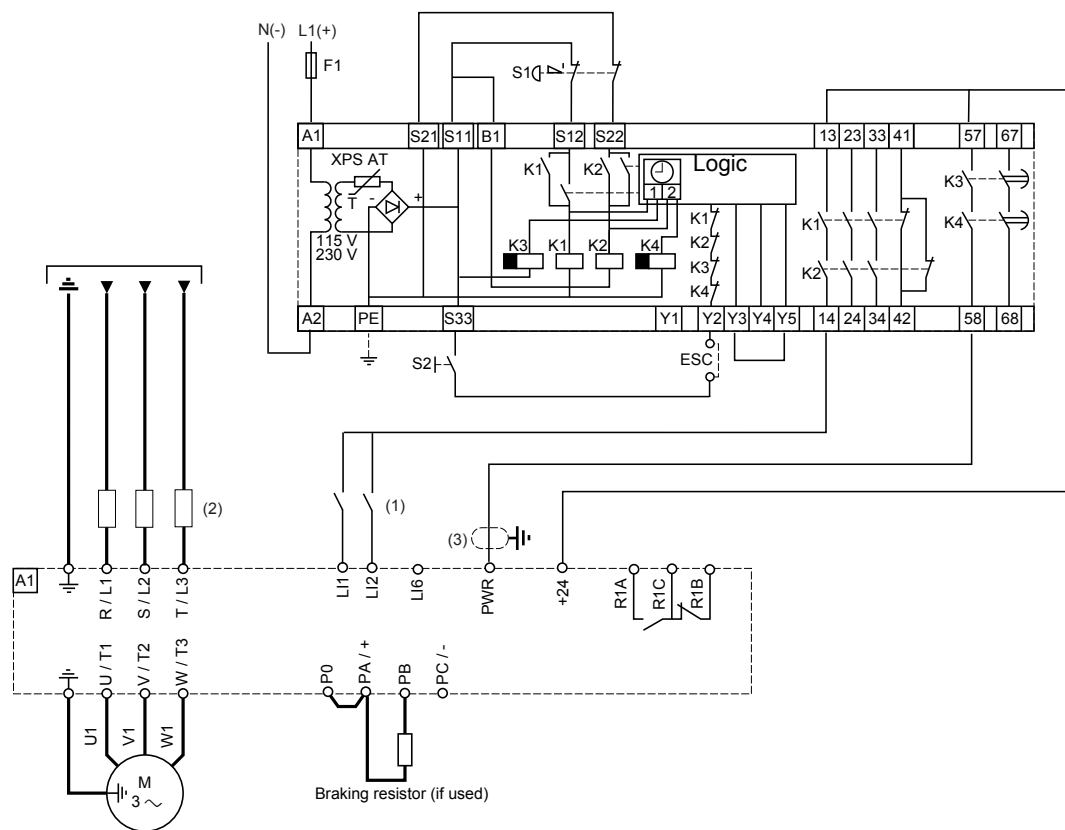

(1) In this example, the logic inputs LIx are wired as "Sink" but can be wired as "Source Int" or "Source Ext".

(2) Line choke (if used)

(3) Standardized coaxial cable, type RG174/U according to MIL-C17 or KX3B according to NF C 93-550, external diameter 2.54 mm, maximum length 15 m. The cable shielding must be earthed.

- Standard IEC/EN 61508 capacity SIL2 and ISO 13849 PL "d" requires the use of a dual-contact stop button (S1).
- S1 is used to activate the Power Removal safety function.
- S2 is used to initialize the Preventa module when powering up or after an emergency stop. ESC enables the use of other initialization conditions for the module.
- One Preventa module can be used for the Power Removal safety function on several ACOPOSinverter P84 drives. In this case the time delay must be set to the longest stopping time.
- A logic output on the Preventa module can be used to indicate reliably that the drive is operating in safe conditions.

Note:

For preventive maintenance, the Power Removal function must be activated at least once a year.

The drive power supply must be turned off and then on again before carrying out this preventive maintenance.

The drive logic output signals cannot be considered as safety-type signals.

Install interference suppressors on all inductive circuits near the drive or coupled to the same circuit (relays, contactors, solenoid valves, etc).

Connection diagrams

Control connection diagrams

Control card connection diagram

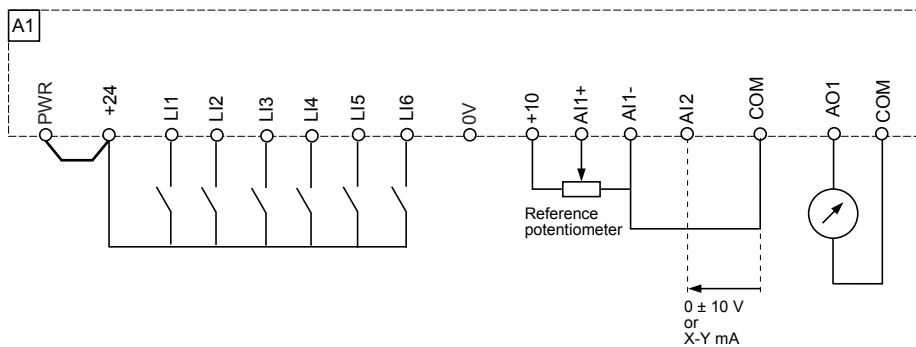

Logic input switch (SW3)

The logic input switch (SW3) is used to adapt the operation of the logic inputs to the technology of the programmable controller outputs.

- If using PLC outputs with PNP transistors set the switches to right position (Sink).
- If using PLC outputs with NPN transistors set the switches to left position (Source Int) or middle position (Source Ext).

Attention: Only switch SW3 with the power off.

- Set SW3 to right position (Sink)

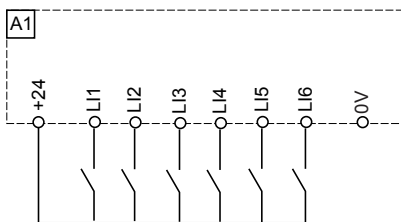

- Set SW3 to right position (Sink) and use of an external power supply for the LIs

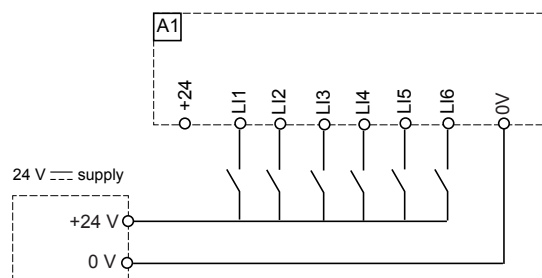

- Set SW3 to left position (Source Int)

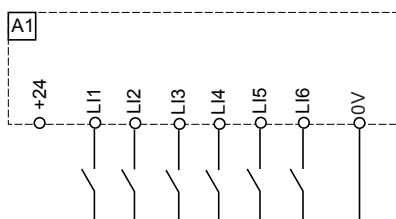

- Set SW3 to middle position (Source Ext)

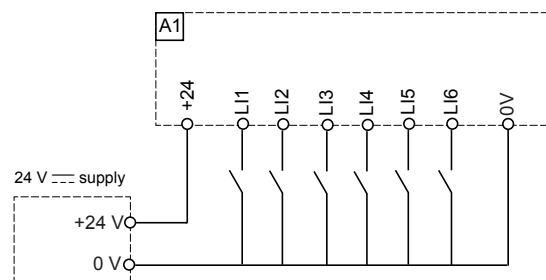

⚠ WARNING

UNINTENDED EQUIPMENT OPERATION

When switch SW3 is set to "Source Int" or "Source Ext", the common must never be connected to ground or the protective ground, as there is then a risk of unintended equipment operation on the first insulation fault.

Failure to follow this instruction can result in death, serious injury or equipment damage.

Connection diagrams

Bipolar speed reference

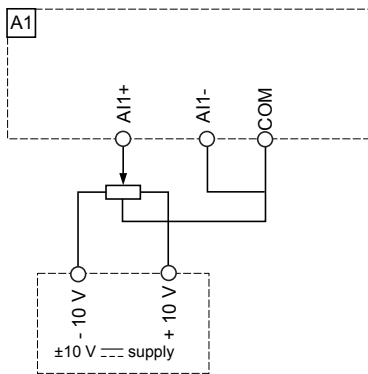

Speed reference using axis control

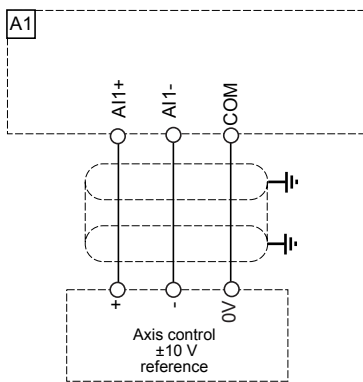

Switch SW1

The LI6 logic input switch (SW1) makes it possible to use the LI6 input:

- Either as a logic input by setting the switch to the right position (factory setting)
- Or for motor protection via PTC probes by setting the switch to the left position

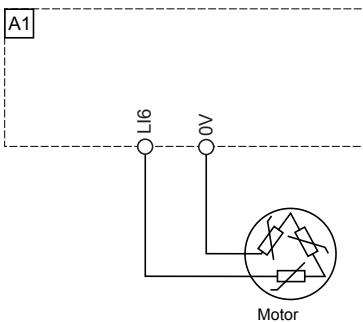

Control power supply via an external source

The control card can be supplied via an external +24 V supply source

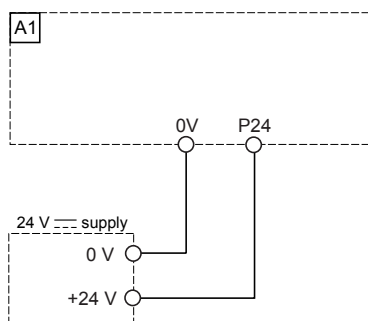

Connection diagrams

Connection of several drives in parallel on the DC bus

It is essential that these drives all have the same voltage rating.

Connection on DC bus between drives with equivalent ratings

Each drive uses its own charging circuit

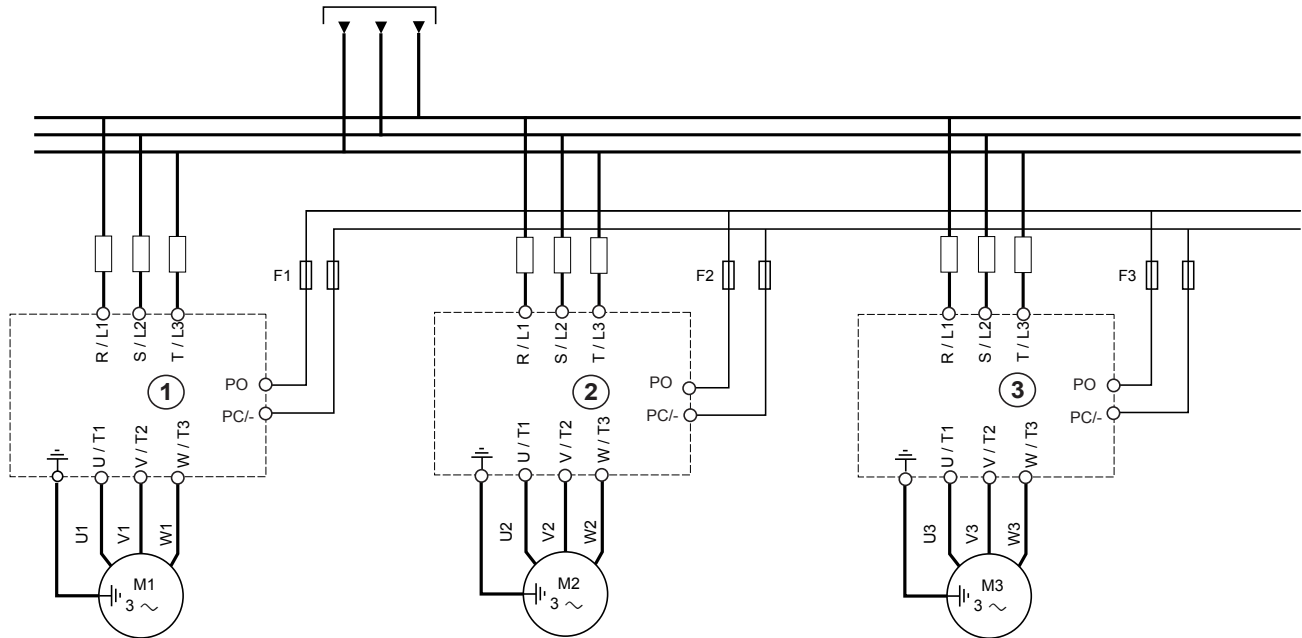

Drives ①, ② and ③ must not be more than one size apart when they are connected in this way.

F1, F2, F3: Fast-acting semiconductor fuses for protection on the DC bus side.

Use on IT system and corner grounded system

IT system: Isolated or impedance grounded neutral. Use a permanent insulation monitor compatible with non-linear loads.

Corner grounded system: System with one phase connected to ground

All 8I84T4*****.01P-1 and 8I84T200037.01P-1 to 8I84T200750.01P-1 drives feature built-in RFI filters. When using drives on an IT system, the link between these filters and ground can be removed as shown in the following diagrams. Removal of this link is possible but not mandatory.

Remove the jumper located to the left of the power terminals (two jumpers for 8I84T402200.01P-1)

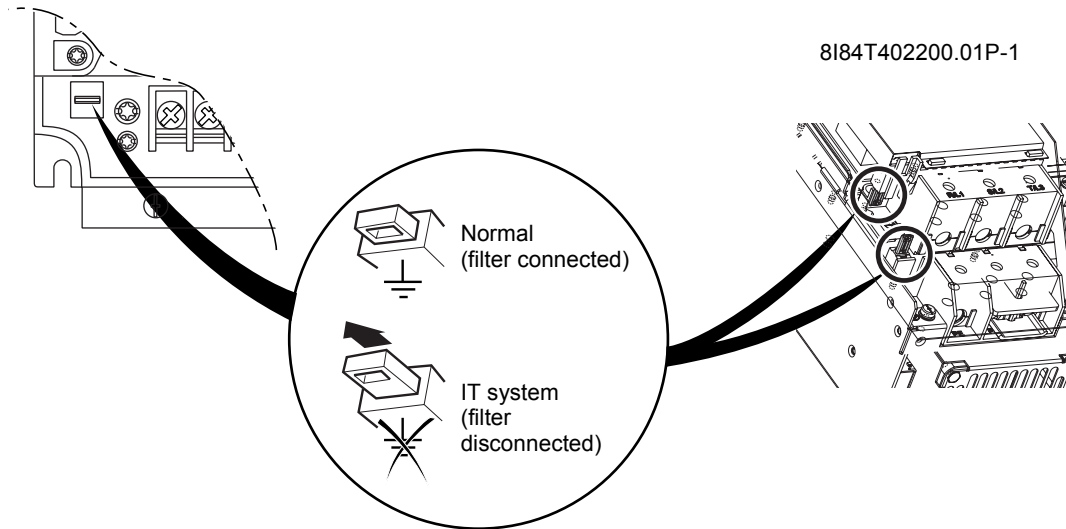

⚠ CAUTION

RISK OF DAMAGE TO THE DRIVE

On 8I84T400075.01P-1 to 8I84T400400.01P-1 ratings, if the filters are disconnected, the drive's switching frequency must not exceed 4 kHz. Refer to the Programming Manual for the corresponding parameter setting.

Failure to follow this instruction can result in injury and/or equipment damage.

Electromagnetic compatibility, wiring

Electromagnetic compatibility

Principle

- Grounds between drive, motor and cable shielding must have “high-frequency” equipotentiality.
- Use of shielded cables with shielding connected to ground at both ends for the motor cables, braking resistor (if used) and control-signal wiring. Metal ducting or conduit can be used for part of the shielding length provided that there is no break in continuity.
- Ensure maximum separation between the power supply cable (line supply) and the motor cable.

Installation diagram

8I84T200037.01P-1 to 8I84T201500.01P-1 and 8I84T400075.01P-1 to 8I84T401850.01P-1

- Attach and ground the shielding of cables **4** and **5** as close as possible to the drive:
 - Strip the shielding.
 - Use stainless steel metal clamps on the parts from which the shielding has been stripped, to attach them to the metal plate **2**. The shielding must be clamped tightly enough to the metal plate to ensure correct contact.
- Install the control EMC plate **11** on the EMC plate **2**, as shown in the diagram.
- Attach and ground the shielding of cables **7**, **12** and **13** as close as possible to the drive:
 - Strip the shielding.
 - Use stainless steel metal clamps on the parts from which the shielding has been stripped, to attach them to the control EMC flange **9**. The shielding must be clamped tightly enough to the metal plate to ensure correct contact.

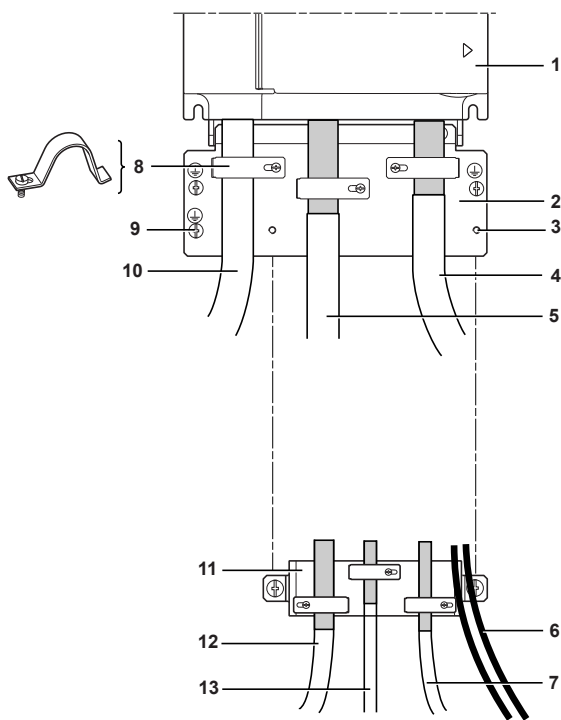

1 ACOPOSinverter P84

2 EMC plate supplied with the drive

3 Tapped holes for installing the control EMC plate

4 Shielded cable for motor connection, with shielding connected to ground at both ends. The shielding must be continuous and intermediate terminals must be in EMC shielded metal boxes.

5 Shielded cable for connecting the braking resistor (if used). The shielding must be continuous and intermediate terminals must be in EMC shielded metal boxes.

6 Non-shielded wires for relay contact output

7 Shielded cables for connecting the Power Removal safety function input. The shielding must be continuous and intermediate terminals must be in EMC shielded metal boxes.

8 Metal clamps

9 Protective ground connection

10 Unshielded power supply cable or wires

11 Control EMC plate

12 Shielded cables for connecting the control-signal section. For applications requiring several conductors, use cables with a small cross-section (0.5 mm² - AWG 20).

13 Shielded cables for connecting the encoder or POWERLINK. The shielding must be continuous and intermediate terminals must be in EMC shielded metal boxes.

Note:

- If using an additional input filter, it should be installed under the drive and connected directly to the line supply via an unshielded cable. Link **10** on the drive is then established via the filter output cable.
- The HF equipotential ground connection between the drive, motor and cable shielding does not remove the need to connect the PE protective conductors (green-yellow) to the appropriate terminals on each unit.

Electromagnetic compatibility, wiring

Installation diagram

8I84T201850.01P-1 to 8I84T204500.01P-1, 8I84T402200.01P-1 to 8I84T407500.01P-1

Attach and ground the shielding of cables **4** and **5** as close as possible to the drive:

- Strip the shielding.
- Use stainless steel metal clamps on the parts from which the shielding has been stripped, to attach them to the metal plate **2**. The shielding must be clamped tightly enough to the metal plate to ensure correct contact.

• Attach and ground the shielding of cables **6**, **7** and **8** as close as possible to the drive:

- Strip the shielding.
- Use stainless steel metal clamps on the parts from which the shielding has been stripped, to attach them to the drive. The shielding must be clamped tightly enough to the metal plate to ensure correct contact.

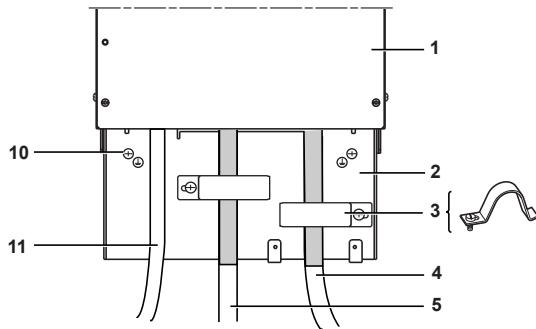

- 1 ACOPOSinverter P84
- 2 EMC plate supplied with the drive
- 3 Metal clamps
- 4 Shielded cable for motor connection, with shielding connected to ground at both ends. The shielding must be continuous and intermediate terminals must be in EMC shielded metal boxes.
- 5 Shielded cable for connecting the braking resistor (if used). The shielding must be continuous and intermediate terminals must be in EMC shielded metal boxes.
- 6 Shielded cables for connecting the control-signal section. For applications requiring several conductors, use cables with a small cross-section (0.5 mm^2 - AWG 20).
- 7 Shielded cables for connecting the Power Removal safety function input. The shielding must be continuous and intermediate terminals must be in EMC shielded metal boxes.
- 8 Shielded cables for connecting the encoder or POWERLINK. The shielding must be continuous and intermediate terminals must be in EMC shielded metal boxes.
- 9 Non-shielded wires for relay contact output
- 10 Protective ground connection
- 11 Unshielded power supply cable or wires

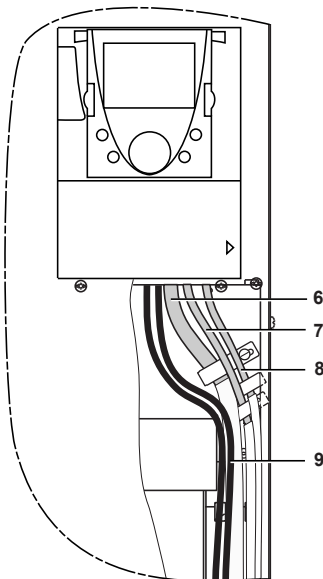

Note:

- If using an additional input filter, it should be installed under the drive and connected directly to the line supply via an unshielded cable. Link **11** on the drive is then established via the filter output cable.
- The HF equipotential ground connection between the drive, motor and cable shielding does not remove the need to connect the PE protective conductors (green-yellow) to the appropriate terminals on each unit.

EMC conditions for ACOPOSinverter P84

For details of permitted length of shielded cable for motor connection please refer to the catalog.

Safety integrated function - Before you begin

Qualification of personnel and use

Qualification of personnel

Only appropriately trained persons who are familiar with and understand the contents of this manual and all other pertinent product documentation are authorized to work on and with this product. In addition, these persons must have received safety training to recognize and avoid hazards involved. These persons must have sufficient technical training, knowledge and experience and be able to foresee and detect potential hazards that may be caused by using the product, by changing the settings and by the mechanical, electrical and electronic equipment of the entire system in which the product is used.

All persons working on and with the product must be fully familiar with all applicable standards, directives, and accident prevention regulations when performing such work.

Intended use

The functions described in this manual are only intended for use with the basic product; you must read and understand the appropriate product manual.

The product may only be used in compliance with all applicable safety regulations and directives, the specified requirements and the technical data.

Prior to using the product, you must perform a risk assessment in view of the planned application. Based on the results, the appropriate safety measures must be implemented.

Since the product is used as a component in an entire system, you must ensure the safety of persons by means of the design of this entire system (for example, machine design).

Operate the product only with the specified cables and accessories. Use only genuine accessories and spare parts.

Any use other than the use explicitly permitted is prohibited and can result in hazards.

Electrical equipment should be installed, operated, serviced, and maintained only by qualified personnel.

The product must NEVER be operated in explosive atmospheres (hazardous locations, Ex areas).

Safety integrated function - Overview

Introduction

The safety function incorporated in ACOPOSinverter P84, allows you to develop applications oriented in the protection of man and machine.

Safety integrated function provides the following benefits:

- Additional standards-compliant safety function
- Replacement of external safety equipment
- Reduced wiring efforts and space requirements
- Reduced costs

The ACOPOSinverter P84 drives are compliant with normative requirements to implement the safety function.

Safety function as per IEC 61800-5-2

PWR (STO)	Power Removal (Safe Torque Off) The function purpose is to bring the motor into a no torque condition so it is relevant in terms of safety since no torque is available at the motor level. Power modules are inhibited and the motor coasts down or prohibits the motor from starting.
-----------	--

Safety integrated function - Overview

Standards and Terminology

Technical terms, terminology and the corresponding descriptions in this manual are intended to use the terms or definitions of the pertinent standards.

In the area of drive systems, this includes, but is not limited to, terms such as "safety function", "safe state", "fault", "fault reset", "failure", "error", "error message", "warning", "warning message", etc.

Among others, these standards include:

- IEC 61800 series: "Adjustable speed electrical power drive systems"
- IEC 61508 series Ed.2: "Functional safety of electrical/electronic/programmable electronic safetyrelated systems"
- EN ISO 13849-1 & 2 Safety of machinery - Safety related parts of control systems

EC Declaration of Conformity

The EC Declaration of Conformity for the EMC Directive can be obtained through your local B&R office.

Certification for functional safety

The integrated safety function is compatible and certified following IEC 61800-5-2 Ed.1 Adjustable speed electrical power drive systems – Part 5-2 : Safety requirements – Functional

IEC 61800-5-2 as a product standard, sets out safety-related considerations of Power Drive Systems Safety Related "PDS (SR) s" in terms of the framework of IEC 61508 series Ed.2 of standards.

Compliance with IEC 61800-5-2 standard, for the following described safety function, will facilitate the incorporation of a PDS(SR) (Power Drive System with safety-related function) into a safety-related control system using the principles of IEC 61508, or the ISO 13849-1, as well as the IEC 62061 for process-systems and machinery.

The defined safety function is:

- SIL 2 capability in compliance with IEC 61800-5-2 and IEC 61508 series Ed.2.
- Performance Level "d" in compliance with ISO 13849-1.

The safety demand mode of operation is considered in high demand or continuous mode of operation according to the IEC 61800-5-2 standard.

The certificate for functional safety is accessible on www.br-automation.com

Safety integrated function - Overview

Basics

Functional Safety

Automation and safety engineering are two areas that were completely separated in the past but recently have become more and more integrated.

Engineering and installation of complex automation solutions are greatly simplified by integrated safety function.

Usually, the safety engineering requirements depend on the application.

The level of the requirements results from the risk and the hazard potential arising from the specific application.

IEC 61508 standard

The standard IEC 61508 "Functional safety of electrical/electronic/programmable electronic safety-related systems" covers the safety-related function. Instead of a single component, an entire function chain (for example, from a sensor through the logical processing units to the actuator) is considered as a unit. This function chain must meet the requirements of the specific safety integrity level as a whole. Systems and components that can be used in various applications for safety tasks with comparable risk levels can be developed on this basis.

SIL - Safety Integrity Level

The standard IEC 61508 defines 4 safety integrity levels (SIL) for safety function. SIL1 is the lowest level and SIL4 is the highest level. A hazard and risk analysis serves as a basis for determining the required safety integrity level. This is used to decide whether the relevant function chain is to be considered as a safety function and which hazard potential it must cover.

PFH - Probability of a dangerous hardware Failure per Hour

To maintain the safety function, the IEC 61508 standard requires various levels of measures for avoiding and controlling detected faults, depending on the required SIL. All components of a safety function must be subjected to a probability assessment to evaluate the effectiveness of the measures implemented for controlling detected faults. This assessment determines the PFH (Probability of a dangerous hardware Failure per Hour) for a safety system. This is the probability per hour that a safety system fails in a hazardous manner and the safety function cannot be correctly executed. Depending on the SIL, the PFH must not exceed certain values for the entire safety system. The individual PFH values of a function chain are added. The result must not exceed the maximum value specified in the standard.

SIL Safety Integrity Level	Probability of a dangerous hardware Failure per Hour (PFH) at high demand or continuous demand
4	$\geq 10^{-9}$... $< 10^{-8}$
3	$\geq 10^{-8}$... $< 10^{-7}$
2	$\geq 10^{-7}$... $< 10^{-6}$
1	$\geq 10^{-6}$... $< 10^{-5}$

PL - Performance Level

The standard IEC 13849-1 defines 5 Performance Levels (PL) for safety function. "a" is the lowest level and "e" is the highest level. Five levels (a, b, c, d, e) correspond to different values of average Probability of dangerous hardware Failure per Hour.

Performance Level	Probability of a dangerous hardware Failure per Hour (PFH)
e	$\geq 10^{-8}$... $< 10^{-7}$
d	$\geq 10^{-7}$... $< 10^{-6}$
c	$\geq 10^{-6}$... $< 3 \cdot 10^{-6}$
b	$\geq 3 \cdot 10^{-6}$... $< 10^{-5}$
a	$\geq 10^{-5}$... $< 10^{-4}$

Safety integrated function - Overview

HFT - hardware detected fault tolerance and SFF - Safe Failure Fraction

Depending on the SIL for the safety system, the IEC 61508 standard and SFF, Safe Failure Fraction requires a specific hardware detected fault tolerance HFT in connection with a specific proportion of safe failures SFF (safe failure fraction).

The hardware detected fault tolerance is the ability of a system to execute the required safety function in spite of the presence of one or more hardware detected faults.

The SFF of a system is defined as the ratio of the rate of safe failures to the total failure rate of the system. According to IEC 61508, the maximum achievable SIL of a system is partly determined by the hardware detected fault tolerance HFT and the safe failure fraction SFF of the system.

IEC 61508 distinguishes two types of subsystems (type A subsystem, type B subsystem). These types are specified on the basis of criteria which the standard defines for the safety-relevant components.

SFF	HFT type A subsystem			HFT type B subsystem		
	0	1	2	0	1	2
< 60%	SIL1	SIL2	SIL3	---	SIL1	SIL2
60% ... < 90%	SIL2	SIL3	SIL4	SIL1	SIL2	SIL3
60% ... < 99%	SIL3	SIL4	SIL4	SIL2	SIL3	SIL4
≥ 99%	SIL3	SIL4	SIL4	SIL3	SIL4	SIL4

Detected fault avoidance measures

Systematic errors in the specifications, in the hardware and the software, usage detected faults and maintenance detected faults of the safety system must be avoided to the maximum degree possible. To meet these requirements, IEC 61508 specifies a number of measures for detected fault avoidance that must be implemented depending on the required SIL. These measures for detected fault avoidance must cover the entire life cycle of the safety system, i.e. from design to decommissioning of the system.

Safety integrated function - Description

(PWR) Power Removal (STO Safe Torque Off)

The purpose of this function is to bring the motor into a no torque condition with motor coasts down or prohibits the motor from starting. So it is relevant in terms of safety since no torque is available at the motor level.

The logic input "PWR" is always assigned to this function.

The PWR (STO) status is accessible with the drive or with Automation Studio.

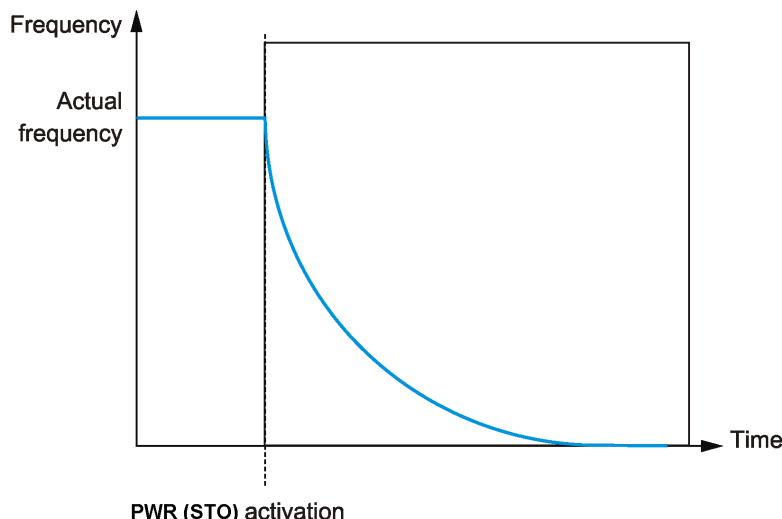

PWR (STO) normative reference

The normative definition of PWR (STO) function is in §4.2.2.2 of the IEC 61800-5-2:

"Power, that can cause rotation (or motion in the case of a linear motor), is not applied to the motor. The PDS(SR)(Power Drive System with safety-related function) will not provide energy to the motor which can generate torque (or force in the case of a linear motor).

- NOTE 1: This safety function corresponds to an uncontrolled stop in accordance with stop category 0 of IEC 60204-1.
- NOTE 2: This safety function may be used where power removal is required to help prevent an unexpected start-up.
- NOTE 3: In circumstances where external influences (for example, falling of suspended loads) are present, additional measures (for example, mechanical brakes) may be necessary to help prevent any hazard.
- NOTE 4: Electronic means and contactors are not adequate for protection against electric shock, and additional measures for isolation may be necessary.

Safety function (SF) level required for PWR (STO) function

Configuration	SIL (Safety Integrity Level) according to IEC 61-508	PL (Performance Level) according to ISO-13849
PWR (STO) with or without Preventa module	SIL 2	PL "d"

The Preventa module (or equivalent) is required for the machine environment because:

- For the machine environment (IEC60204-1 & Machine Directive), reset shall not initiate a restart in any cases. One of the most stringent case is when PWR (STO) is activated, then the power supply is switched off. In this case, if PWR (STO) is deactivated during the loss of supply, the motor does not have to restart automatically. The Preventa module can prevent a spurious restart in the previous condition. So the Preventa module is mandatory for machine applications.
- E_stop of several BDM in a PDS: the Preventa module has some safety outputs for application which requires one or several safety outputs.

For other environments, the Preventa module is not required, except if the application requires it: System fallback position.