

Altistart® 01 Soft Starts

Catalog
04

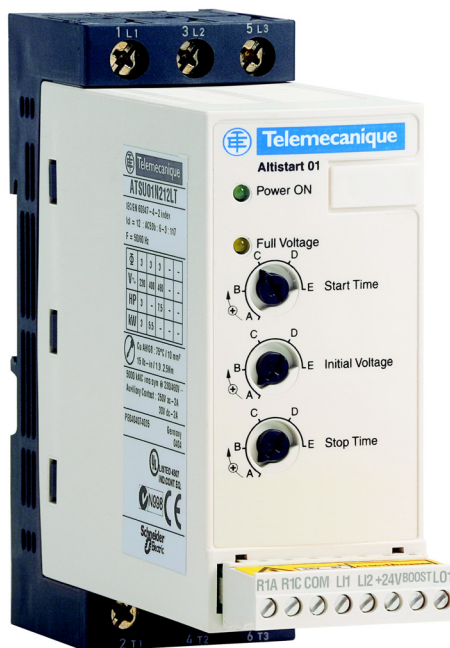

Soft Starts for Single-Phase and Three-Phase Asynchronous Motors

Low Power Mini Soft Starts	3
6 to 32 A	
208 to 480 V (3-phase)	
1/2–20 hp (0.75 to 15 kW)	
High Power Mini Soft Starts	33
32 to 85 A	
208 to 690 V (3-phase)	
10 to 75 hp (7.5 to 75 kW)	
Torque Limiting Soft Starts	49
3 to 12 A	
120 to 480 V (single or 3-phase)	
1/4–7.5 hp (0.37 to 5.5 kW)	

Product Support and Special Symbols

Product Support

For support and assistance, contact the Product Support Group. The Product Support Group is staffed from 8:00 am until 6:00 pm Eastern time to assist with product selection, start-up, and diagnosis of product or application problems. Emergency phone support is available 24 hours a day, 365 days a year.

Telephone	919-266-8600
Toll Free	888-Square D (888-778-2733)
E-mail	drive.products.support@us.schneider-electric.com
Fax	919-217-6508

Special Symbols

Throughout this catalog, the symbol “•” in a catalog number, for example ATSU01N2•LT, designates a character in the number that varies with the product rating.

Overview

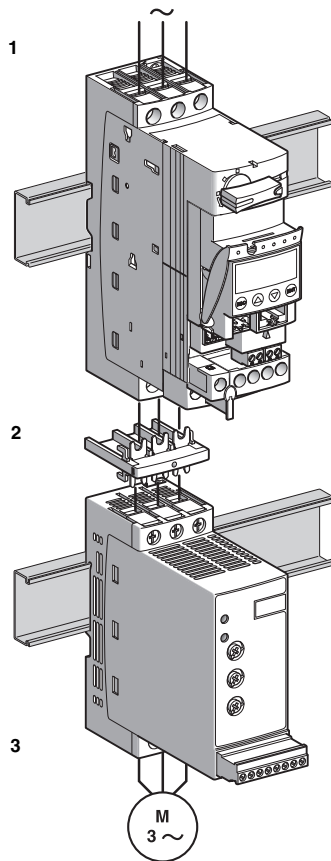

While Altistart® 01 (ATS01) soft starts can be used with almost any motor starter, they now add soft start and soft stop motor control to the TeSys® U-Line family of motor starters.

When an ATS01N2••LU/QN/RT or an ATSU01N2••LT model (3) is combined with the TeSys U-Line motor starter (1) by means of a power connector (2), the result is a unique, innovative motor starting solution. A low power soft start installation now has access to all of the benefits of the TeSys U-Line motor starter, including:

- modular design with a standard 45 mm width
- short-circuit and multi-class overload protection
- phase loss, phase imbalance, ground fault, jam, underload, and long-start protection
- fault history
- PC and PDA based programming software
- optional LCD display
- networking capabilities: Modbus, AS-I, DeviceNet, Ethernet TCP/IP, Profibus DP
 - monitoring of motor status
 - remote starting and fault reset
- electronic reversing

The ATSU01N2••LT soft start is optimized for installations offering 24 Vdc control power.

The ATS01N2••LU/QN/RT soft start is self-powered from the AC line supply and is compatible with all other control power schemes.

The panel space required to install the ATS01 soft start and the TeSys U-Line motor starter is minimal, with a standard 45 mm product width and side-by-side mounting. Please consult the TeSys U-Line motor starter catalog (8502CT0201) for TeSys U-Line mounting information. The catalog is available at www.us.squared.com.

The ATS01 soft start enhances the starting performance of asynchronous motors by allowing them to start gradually, smoothly, and in a controlled manner. It is ideal for applications that do not require high starting torque. It limits starting torque and reduces the current inrush experienced with other motor starting methods.

The transitionless starting method of the ATS01 soft start avoids the torque surges associated with other reduced voltage starting methods.

Using the ATS01 soft start avoids the damage and expense associated with full voltage starting, such as:

- wear and tear to motors, shafts, bearings, clutches, belts, and other attached machinery
- damage to product due to sudden starts and stops
- production downtime and material waste
- maintenance labor and replacement equipment cost

The ATS01 soft start is designed for the following simple applications:

- material handling conveyors
- belt-driven machinery
- fans and pumps
- small compressors
- automatic doors and gates
- process machinery (such as grinders, mixers, and agitators)
- filling lines
- people movers
- any other application that can benefit from stepless reduced voltage starting

The ATS01 low power mini soft start is compact and easy to install. It was designed to meet IEC 60947-4-2, the internationally accepted standard defining soft starts, and carries the following agency approvals: UL, CSA, CCC, C-Tick, and CE.

Low Power Mini Soft Starts

Description

Description

The Altistart® 01 low power mini soft starts:

- control two phases of the AC voltage supplying the motor to limit starting torque and current
- have motor power ratings of 1/2 to 20 hp (0.75 to 15 kW), three-phase only have a motor voltage range of 208 to 460 V

They are equipped with:

- a potentiometer to set the starting time (3)
- a potentiometer to set the stopping time (5)
- a potentiometer to set the initial voltage applied to the motor when starting begins (4)
- 1 green LED (1) to indicate that soft start power is on
- 1 yellow LED (2) that illuminates 10 seconds after a start command is given indicating that the soft start's voltage ramp is complete, the internal shorting contactor is closed, and the motor is up to speed
- a removable I/O terminal block (6) that includes:
 - 2 logic or control inputs for Run and Stop commands
 - 1 logic or control input for the Boost or Kickstart function
 - 1 open collector logic or signal output to indicate that the soft start ramp is complete and the motor is up to speed
 - 1 normally-open relay contact that is closed when the soft start is running the motor and open if the soft start is faulted or if the motor has stopped

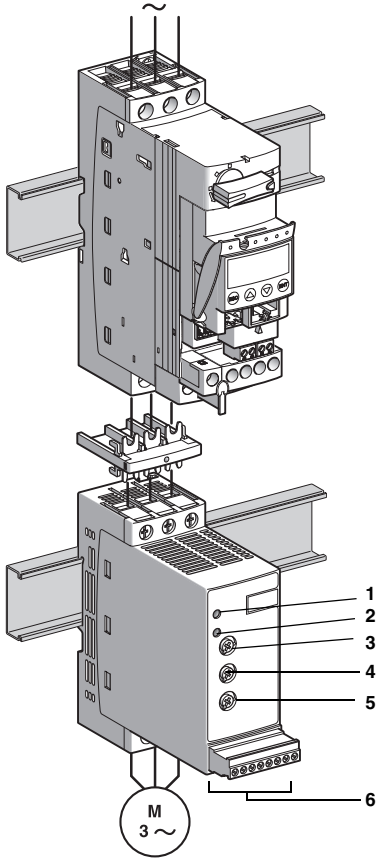

Altistart® 01 soft start functions

■ 2-wire control

The start and stop commands are provided by a single logic or control input. As soon as the state of logic input 2 (LI2) goes high (connected to the LI+ or +24 V terminal), the starting process begins. As soon as the state of LI2 goes low (the connection to LI+ or +24 V is removed), the stopping process begins. No connection to LI1 is required.

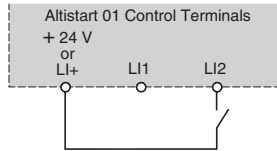

Wiring diagram for 2-wire control

■ 3-wire control

The start and stop commands are provided by two different logic or control inputs. While logic input 1 (LI1) is continuously held high (connected to LI+ or +24 V), a momentary high on LI2 will provide a start command. A stop command is issued as soon as LI1 goes low (the connection to LI+ or +24 V is removed). To issue a second start command, reconnect LI1 to LI+ or +24 V and momentarily pull LI2 high.

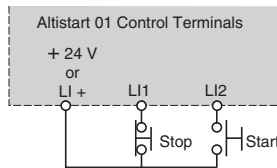

Wiring diagram for 3-wire control

■ Starting and stopping times

The ATS01 soft start controls the starting and stopping time of the motor by ramping the applied motor voltage up and down. The starting and stopping voltage ramp times can be adjusted from 1 to 10 seconds by means of two potentiometers on the front of the soft start. Since the actual motor starting and stopping times are dependent on the level of the applied load, the scale on the front of the soft start is calibrated from A to E rather than from 1 to 10 seconds, with A being the shortest time and E being the longest time. The starting voltage ramp begins at the AC voltage level set by the Initial Voltage adjustment. See the diagram below for more detail. See page 6 for more information about Initial Voltage.

Note: The ATS01 soft start is internally bypassed at the end of the time set by the start time adjustment. If the motor is not up to speed by that time (due to a heavy load), the internal contactor can be damaged, requiring replacement of the soft start.
SET THE START TIME AT A LEVEL ACHIEVABLE WITH THE MOTOR AT ITS HIGHEST LOAD LEVEL.

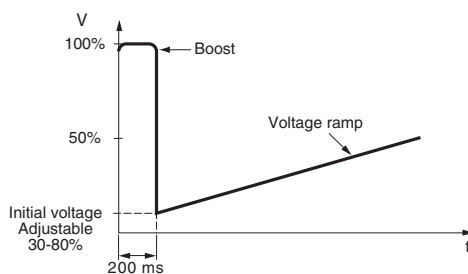

Voltage ramp, initial voltage, and boost

Low Power Mini Soft Starts Functions

■ Initial (or starting) voltage

The initial voltage applied to the motor (the level at which the voltage ramp begins) can be adjusted by a potentiometer on the face of the Altistart® 01 (ATS01) soft start. The initial voltage level can be adjusted from approximately 30 to 80% of the AC line voltage. Since the resultant motor torque varies in proportion to the square of the applied voltage (see the diagram below), the scale on the front of the ATS01 is calibrated from A to E rather than from 30 to 80%, with A being the lowest level and E being the highest level. A lower setting will reduce motor current and torque during starting. Set this level to the minimum required that will result in motor rotation immediately after a start command. If no level of adjustment here starts immediate motor rotation, use the Boost function. See the diagram on page 5 for more detail.

Torque characteristics (typical curves)

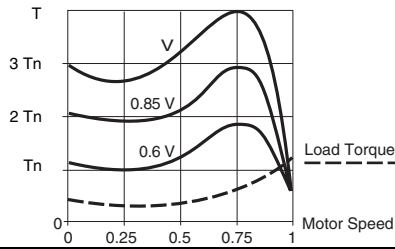

This diagram shows the torque/speed characteristic of a squirrel cage motor in relation to the applied voltage. The torque varies in proportion to the squared ratio of the applied voltage to the motor's rated voltage at a fixed frequency. For example, 1/2 voltage results in approximately 1/4 torque. The gradual increase in the voltage prevents the instantaneous current peak on start up.

■ Boost (kickstart) function

If the Boost control input is active (connected to LI+ or +24 V) when a start command is given, full line voltage will be applied to the motor for the first 200 mS of soft start operation. Thereafter, the normal voltage ramp will resume. Use this function to start high inertia loads or applications with a high level of starting friction. See the diagram on page 5 for more detail.

■ Motor up to speed

The ATS01 soft start provides a logic signal to indicate that the starting voltage ramp is complete and the motor is up to speed. This signal is provided by an open collector output illustrated in the diagrams below. An external power supply is required to complete this circuit.

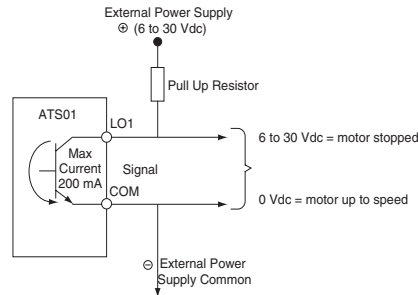

OR -----

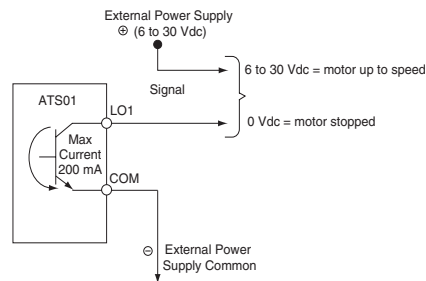

■ The ATS01 soft start provides a relay contact to indicate either that it has faulted or that it has stopped running the motor. The normally-open contact between terminals R1A and R1C closes when a run command is provided at LI2. The relay contact opens under either one of the following two conditions:

- the contact opens instantly when the soft start experiences a fault condition.
- the contact opens when the motor voltage reaches zero after a stop command.

This information can be used to sequence a contactor if both line isolation and soft stop are needed in the same application.

Low Power Mini Soft Starts Characteristics

Environment

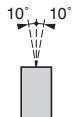
Type of starter	ATS	U01N2●●LT	01N2●●LU	01N2●●QN	01N2●●RT
Conformity to standards		Altistart® 01 soft starts conform to the strictest international standards and recommendations relating to electrical industrial control devices, in particular the standard IEC 60947-4-2.			
Electromagnetic compatibility EMC					
	Conducted and radiated emissions	CISPR 11 level B, IEC 60947-4-2, level B			
	Harmonics	IEC 61000-3-2, IEC 61000-3-4			
	EMC immunity	EN 50082-2, EN 50082-1			
	Electrostatic discharge	IEC 61000-4-2 level 3			
	Immunity to radiated radio-frequency electromagnetic field	IEC 61000-4-3 level 3			
	Immunity to electrical transients	IEC 61000-4-4 level 4			
	Surge immunity	IEC 61000-4-5 level 3			
	Immunity to conducted interference caused by radio-electrical fields	IEC 61000-4-11			
	Immunity to voltage disturbances	IEC 61000-4-6 level 3			
	Damped oscillating waves	IEC 61000-4-12 level 3			
CE marking		The soft starts are CE marked on the basis of European directives governing low voltage (72/73/EEC) and EMC (89/336/EEC).			
Product certification		UL, CSA, CCC, and C-Tick			
Degree of protection		IP20			
Degree of pollution		2 (conforming to IEC 60947-4-2)			
Vibration resistance		1.5 mm peak to peak from 3 to 13 Hz, 1 gn from 13 to 150 Hz conforming to IEC 60068-2-6			
Shock resistance		15 gn for 11 ms conforming to IEC 60068-2-27			
Relative humidity		5-95% without condensation or dripping water, conforming to IEC 60068-2-3			
Ambient temperature around the unit	Storage	- 25 to + 70 °C (-13 to +158 °F) conforming to IEC 60947-4-2			
	Operation	- 10 to + 40 °C (+14 to +104 °F) without derating, up to 50 °C (122 °F) with current derating of 2% per °C above 40 °C (1.1% per °F above 104 °F)			
Maximum operating altitude		1000 m (3300 ft) without derating Above this, derate the current by 2.2% per additional 100 m (330ft).			
Side-by-side mounting		No gap between soft starts is required			
Operating position Maximum permanent angle in relation to a vertical mounting position					

Low Power Mini Soft Starts Characteristics

Electrical characteristics

Type of starter	ATS	U01N2●●LT	01N2●●LU	01N2●●QN	01N2●●RT	
Category of use	Conforming to IEC 60947-4-2	AC-53b				
Rated AC supply voltage	3-phase only	200–480 Vac	200–240 Vac	380–415 Vac	440–480 Vac	
AC line voltage tolerance		-15% to +10%				
Frequency		50 or 60 Hz ± 5%				
Output voltage		Maximum 3-phase voltage equal to AC supply voltage.				
Control supply voltage		24 Vac/dc ± 10%	No external control power needed.			
Rated operating current		6, 9, 12, 22, and 32 A				
Adjustable starting time		1–10 s				
Adjustable deceleration time		1–10 s				
Starting voltage		30–80% of motor's rated voltage				
Type of starter	ATSU01N2	06LT	09LT	12LT	22LT	32LT
Control power supply consumption		24 Vac/dc, 65 mA			24 Vac/dc, 100 mA	
Power dissipated	At full load at the end of starting	1.5 W	1.5 W	1.5 W	2.5 W	2.5 W
	During starting and stopping at 5 times the rated operating current	61.5 W	91.5 W	121.5 W	222.5 W	322.5 W
Type of starter	ATS01N2	06LU/QN/RT	09LU/QN/RT	12LU/QN/RT	22LU/QN/RT	32LU/QN/RT
Power dissipated	At full load at the end of starting	4 W	4 W	4 W	4.5 W	4.5 W
	During starting and stopping at 5 times the rated operating current	64 W	94 W	124 W	224.5 W	324.5 W
Type of starter	ATSU01N206LT to ATSU01N222LT ATS01N206●● to ATS01N222●●			ATSU01N232LT ATS01N232●●		
Starting time at 5 times the rated operating current	1 s	5 s	1 s	5 s		
Max. number of cycles per hour	310	20	180	10		

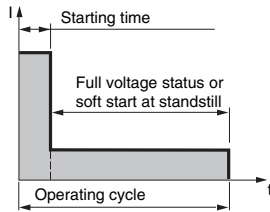

ATS01 Control Terminals

ATSU01N2●●LT

R1A	R1C	COM	LI1	LI2	24V	BOOST	LO1
-----	-----	-----	-----	-----	-----	-------	-----

ATS01N2 ●●LU/QN/RT

R1A	R1C	COM	LI1	LI2	LI+	BOOST	LO1
-----	-----	-----	-----	-----	-----	-------	-----

Control Terminal Description	ATSU01N2●●LT	ATS01N2●●LU/QN/RT
24 V and COM or LI+ and COM Control power (electrical isolation between line power and control power)	24 V ±10% from external power supply Connect to terminals +24 V and COM Max. required current 100 mA	24 V from ATS01 internal power supply LI+ and COM Max. available current 10 mA No short-circuit or overload protection.
LI1, LI2, Boost Logic inputs Stop, Run and Boost (Kickstart) functions	27 kohms input impedance 40 Vdc maximum input signal Max. current 8 mA State 0 if signal < 5 V State 1 if signal > 13 V	
LO1 End of starting signal	Open collector logic output External power supply (minimum 6 Vdc, maximum 30 Vdc) Max current 200 mA	
R1A R1C Relay output Fault signal and isolation contactor control Relay contact is open when soft start is not running or when it is faulted.	Normally-open (N.O.) contact Minimum switching capacity: 10 mA at 6 Vdc Max. switching capacity on inductive load (cos φ = 0.5 and L/R = 20 ms): 2 A at 250 Vac or 30 Vdc (AC-15) Max. operating voltage 440 Vac	
LED signalling		
Green LED	Soft start power on	
Yellow LED	Voltage ramp complete, motor up to speed	

Overview:
pages 3–6

Dimensions:
page 10

Selection:
pages 11–12

Wiring Diagrams:
pages 13–31

Low Power Mini Soft Starts Characteristics

Connections (Maximum connection capacity and tightening torque)

A customized power connector is supplied with the ATSU01N2●●LT soft starts. It eliminates the need for power wiring between the soft start and the TeSys® U-Line motor starter and minimizes the height of the assembly when the two units are mounted one above the other. For ATSO1N2●●LU/QN/RT soft starts, the power connector is available as an option (part number VW3G4104).

Power circuit		Connection onto Ø 4 mm screw terminals
Stranded wire without cable end	1 conductor	1.5–10 mm ² (16–8 AWG)
	2 conductors	1.5–6 mm ² (16–10 AWG)
Stranded wire with cable end	1 conductor	1–6 mm ² (16–10 AWG)
	2 conductors	1–6 mm ² (16–10 AWG)
Solid wire	1 conductor	1–10 mm ² (16–8 AWG)
	2 conductors	1–6 mm ² (16–10 AWG)
Tightening torque		1.9–2.5 N•m (16.9–22.1 in-lb)
Control circuit		Screw connector
Stranded wire without cable end	1 conductor	0.5–2.5 mm ² (20–14 AWG)
	2 conductors	0.5–1.5 mm ² (20–16 AWG)
Stranded wire with cable end	1 conductor	0.5–1.5 mm ² (20–16 AWG)
	2 conductors	0.5–1.5 mm ² (20–16 AWG)
Solid wire	1 conductor	0.5–2.5 mm ² (20–14 AWG)
	2 conductors	0.5–1 mm ² (20–18 AWG)
Tightening torque		0.5 N•m (4.4 in-lb)

Low Power Mini Soft Starts Dimensions

TeSys® U-Line combination (non-reversing power base) and
ATSU01N206LT to ATSU01N212LT or
ATS01206LU/QN/RT to ATSO1N212LU/QN/RT

Mounting on  (35 mm) DIN rail with VW3G4104 connector

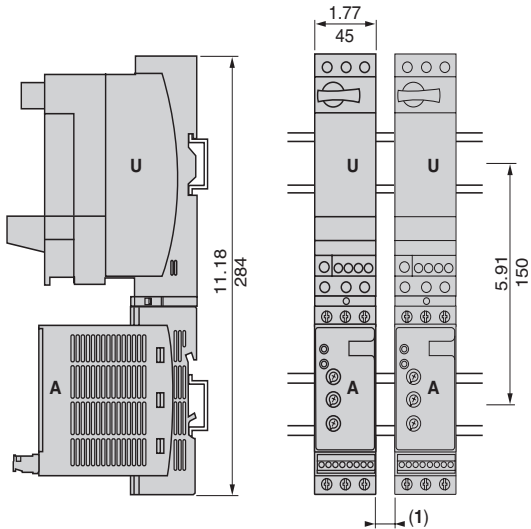

TeSys U-Line combination (non-reversing power base) and
ATSU01N222LT to ATSU01N232LT or
ATS01N222LU/QN/RT to ATSO1N232LU/QN/RT

Mounting on  (35 mm) DIN rail with VW3G4104 connector

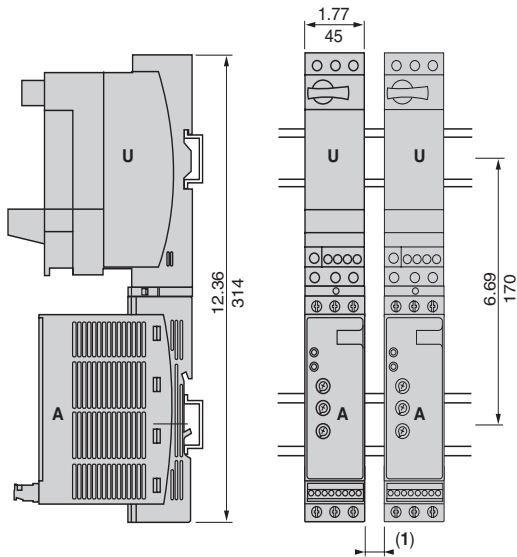

VW3G4104 connector

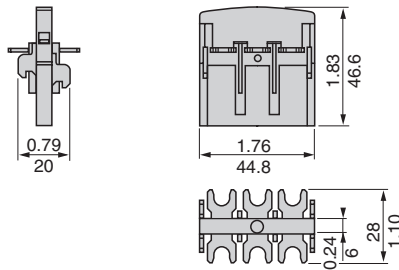

TeSys U-Line combination (non-reversing or reversing power base) and
ATSU01N206LT to ATSU01N212LT or ATS01206LU/QN/RT to ATSO1N212LU/QN/RT

Side-by-side mounting

Panel mounting

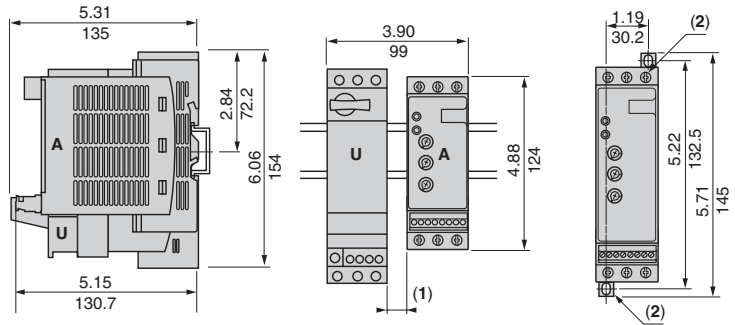

Dimensions: $\frac{\text{in.}}{\text{mm}}$

TeSys U-Line combination (non-reversing or reversing power base) and
ATSU01N222LT to ATSU01N232LT or
ATS01N222LU/QN/RT to ATSO1N232LU/QN/RT

Side-by-side mounting

Panel mounting

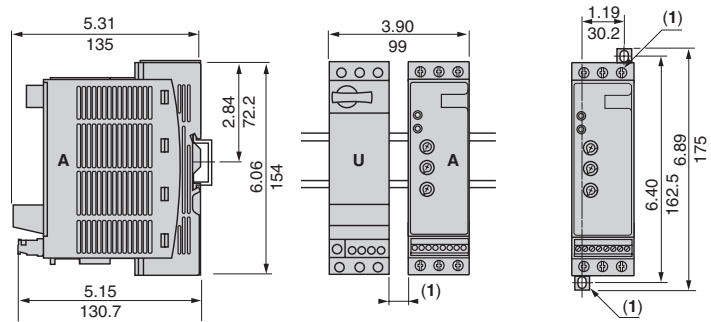

Dimensions: $\frac{\text{in.}}{\text{mm}}$

(1) Gap only required when using a TeSys U type LUCM multifunction control unit in an ambient temperature above 113 °F (45 °C). See TeSys U-Line motor starter catalog number 8502CT0201 for more information.

(2) Retractable screw tabs.

A – ATS01 soft start.

U – TeSys U-Line motor starter.

Overview:
pages 3–6

Characteristics:
pages 7–9

Selection:
pages 11–12

Wiring Diagrams:
pages 13–31

Low Power Mini Soft Starts Selection

Altistart® 01 soft start and TeSys® U-Line motor starter combinations

Numerous combination possibilities exist. Consult the TeSys U-Line Motor Starter catalog, number 8502CT0201, for more information.

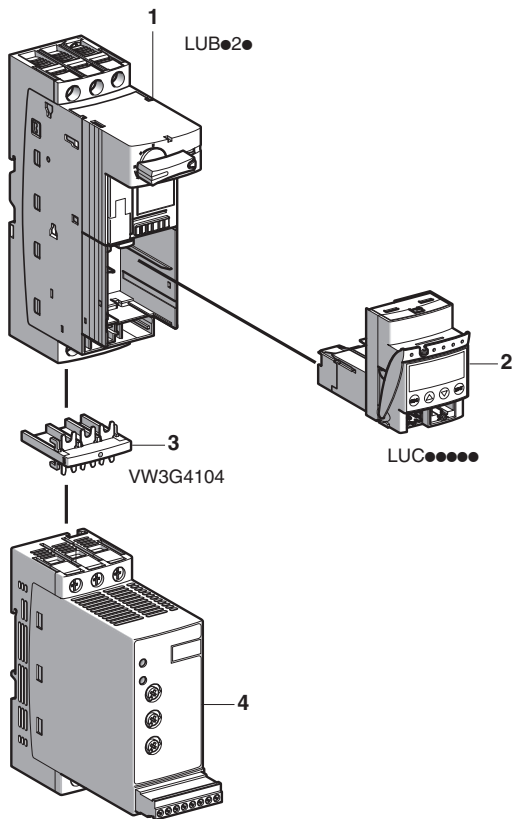

ATS●01N2●●●●

Example of motor starter/soft start combination:

- 1 TeSys U-Line non-reversing power base
- 2 TeSys U-Line control unit
- 3 Power connector – supplied with ATSU01 soft start
- 4 Altistart 01 soft start

Motor Power (1)				24 Vdc Control Power		
Voltage	kW	hp	ATS01 Rated Current A	ATSU01 Soft Start	TeSys U-Line	
					Power Base	Control Module (2)
230 V	0.75	1	6	ATSU01N206LT	LUB12	LUC●05BL
	1.1	1.5	6	ATSU01N206LT	LUB12	LUC●12BL
	1.5	2	9	ATSU01N209LT	LUB12	LUC●12BL
	2.2	3	12	ATSU01N212LT	LUB12	LUC●12BL
	3	–	12	ATSU01N212LT	LUB32	LUC●18BL
	4	5	22	ATSU01N222LT	LUB32	LUC●18BL
	5.5	7.5	22	ATSU01N222LT	LUB32	LUC●32BL
400 V	7.5	10	32	ATSU01N232LT	LUB32	LUC●32BL
	1.5	–	6	ATSU01N206LT	LUB12	LUC●05BL
	2.2	–	6	ATSU01N206LT	LUB12	LUC●12BL
	3	–	9	ATSU01N209LT	LUB12	LUC●12BL
	4	–	9	ATSU01N209LT	LUB12	LUC●12BL
	5.5	–	12	ATSU01N212LT	LUB32	LUC●32BL
	7.5	–	22	ATSU01N222LT	LUB32	LUC●32BL
460 V	11	–	22	ATSU01N222LT	LUB32	LUC●32BL
	15	–	32	ATSU01N232LT	LUB32	LUC●32BL
	2	6	6	ATSU01N206LT	LUB12	LUC●05BL
	3	6	6	ATSU01N206LT	LUB12	LUC●12BL
	5	9	9	ATSU01N209LT	LUB12	LUC●12BL
	7.5	12	12	ATSU01N212LT	LUB32	LUC●18BL

Motor Power (1)				120 Vac Control Power		
Voltage	kW	hp	ATS01 Rated Current A	ATS01 Soft Start	TeSys U-Line	
					Power Base	Control Module (2)
230 V	0.75	1	6	ATS01N206LU	LUB12	LUC●05FU
	1.1	1.5	6	ATS01N206LU	LUB12	LUC●12FU
	1.5	2	9	ATS01N209LU	LUB12	LUC●12FU
	2.2	3	12	ATS01N212LU	LUB12	LUC●12FU
	3	–	12	ATS01N212LU	LUB32	LUC●18FU
	4	5	22	ATS01N222LU	LUB32	LUC●18FU
	5.5	7.5	22	ATS01N222LU	LUB32	LUC●32FU
400 V	7.5	10	32	ATS01N232LU	LUB32	LUC●32FU
	1.5	–	6	ATS01N206QN	LUB12	LUC●05FU
	2.2	–	6	ATS01N206QN	LUB12	LUC●12FU
	3	–	9	ATS01N209QN	LUB12	LUC●12FU
	4	–	9	ATS01N209QN	LUB12	LUC●12FU
	5.5	–	12	ATS01N212QN	LUB32	LUC●32FU
	7.5	–	22	ATS01N222QN	LUB32	LUC●32FU
460 V	11	–	22	ATS01N222QN	LUB32	LUC●32FU
	15	–	32	ATS01N232QN	LUB32	LUC●32FU
	2	6	6	ATS01N206RT	LUB12	LUC●05FU
	3	6	6	ATS01N206RT	LUB12	LUC●12FU
	5	9	9	ATS01N209RT	LUB12	LUC●12FU
	7.5	12	12	ATS01N212RT	LUB32	LUC●18FU

(1) Standard power rating according to UL508.

(2) Depending on the configuration of the selected TeSys U-Line motor starter, replace the ● with A for standard, B for advanced, and M for multifunction.

Accessory for ATS01N2●●LU/QN/RT models

Description	Catalog Number
Power connector between ATS01 soft start and TeSys U-Line motor starter (included with ATSU01 soft start)	VW3G4104

See page 12 for equipment selection tables when combining the ATS01 soft start with other motor starting equipment.

Low Power Mini Soft Starts Selection

Altistart® 01 soft start combinations with other Telemecanique motor starting equipment

Motor hp		ATS01 Soft Start	GV Manual Starter	KM1 Isolation Contactor	Fast-acting Class J Fuses (1)	Overload Relay (2)
200/208 V	230/240 V					
1/2	1/2	ATS01N206LU	GV2ME07	LC1D09 or LC1K06	10 A	LRD07 or LR2K0308
	3/4	ATS01N206LU	GV2ME08	LC1D09 or LC1K06	10 A	LRD08 or LR2K0310
3/4		ATS01N206LU	GV2ME08	LC1D09 or LC1K06	15 A	LRD08 or LR2K0310
1	1	ATS01N206LU	GV2ME10	LC1D09 or LC1K06	15 A	LRD10 or LR2K0312
	1.5	ATS01N206LU	GV2ME10	LC1D09 or LC1K06	20 A	LRD12 or LR2K0314
	2	ATS01N209LU	GV2ME14	LC1D09 or LC1K09	20 A	LRD12 or LR2K0314
1.5-2		ATS01N209LU	GV2ME14	LC1D09 or LC1K09	25 A	LRD12 or LR2K0314
	3	ATS01N212LU	GV2ME16	LC1D12 or LC1K12	30 A	LRD16 or LR2K0316
3		ATS01N212LU	GV2ME16	LC1D12 or LC1K12	35 A	LRD16 or LR2K0316
	5	ATS01N222LU	GV2ME20	LC1D18	50 A	LRD21
5		ATS01N222LU	GV2ME20	LC1D18	60 A	LRD22
	7.5	ATS01N222LU	GV2ME21	LC1D25	70 A	LRD22
7.5		ATS01N232LU	GV2ME32	LC1D25	80 A	LRD32
	10	ATS01N232LU	GV2ME32	LC1D32	90 A	LRD32
10		ATS01N232LU	GV2ME32	LC1D32	100 A	LRD35

Motor		ATS01 Soft Start	GV Manual Starter	KM1 Isolation Contactor	Fast-acting Class J Fuses (1)	Overload Relay (2)
kW	400 V					
1.1		ATS01N206QN	GV2ME07	LC1D09 or LC1K06	10 A	LRD07 or LR2K0308
1.5		ATS01N206QN	GV2ME08	LC1D09 or LC1K06	15 A	LRD08 or LR2K0310
2.2		ATS01N206QN	GV2ME10	LC1D09 or LC1K06	15 A	LRD10 or LR2K0312
3		ATS01N209QN	GV2ME14	LC1D09 or LC1K09	20 A	LRD12 or LR2K0314
4		ATS01N209QN	GV2ME14	LC1D09 or LC1K09	25 A	LRD14 or LR2K0316
5.5		ATS01N212QN	GV2ME16	LC1D12 or LC1K12	35 A	LRD16 or LR2K0316
7.5		ATS01N222QN	GV2ME20	LC1D18	45 A	LRD21
9		ATS01N222QN	GV2ME21	LC1D25	60 A	LRD22
11		ATS01N222QN	GV2ME21	LC1D25	70 A	LRD22
15		ATS01N232QN	GV2ME32	LC1D32	90 A	LRD32

Motor		ATS01 Soft Start	GV Manual Starter	KM1 Isolation Contactor	Fast-acting Class J Fuses (1)	Overload Relay (2)
hp	460 V					
1/2		ATS01N206RT	GV2ME06	LC1D09 or LC1K06	3 A	LRD06 or LR2K0306
3/4		ATS01N206RT	GV2ME06	LC1D09 or LC1K06	6 A	LRD06 or LR2K0307
1		ATS01N206RT	GV2ME07	LC1D09 or LC1K06	6 A	LRD07 or LR2K0308
1.5-2		ATS01N206RT	GV2ME08	LC1D09 or LC1K06	10 A	LRD08 or LR2K0310
3		ATS01N206RT	GV2ME10	LC1D09 or LC1K06	15 A	LRD10 or LR2K0312
5		ATS01N209RT	GV2ME14	LC1D09 or LC1K09	25 A	LRD12 or LR2K0314
7.5		ATS01N212RT	GV2ME16	LC1D12 or LC1K12	35 A	LRD16 or LR2K0316
10		ATS01N222RT	GV2ME20	LC1D18	45 A	LRD21
15		ATS01N222RT	GV2ME21	LC1D25	70 A	LRD22
20		ATS01N232RT	GV2ME32	LC1D32	90 A	LRD32

- (1) Fuses are not required when using the GV manual starter with motor branch-circuit protection installed per NEC article 430.
 (2) The overload relay is not required when using the GV manual starter.

Altistart® 01 soft start and TeSys® U-Line motor starter combinations

ATSU01N2●●LT

ATS01N2●●LU/QN/RT

Automatic 2-wire control without soft stop

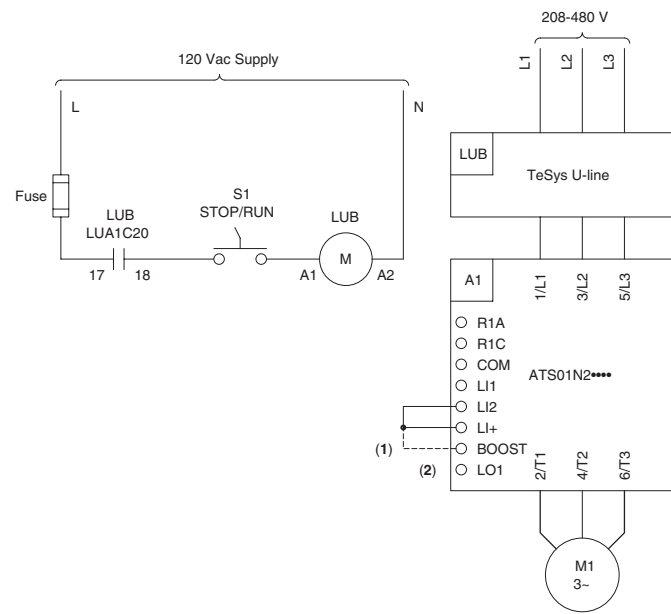
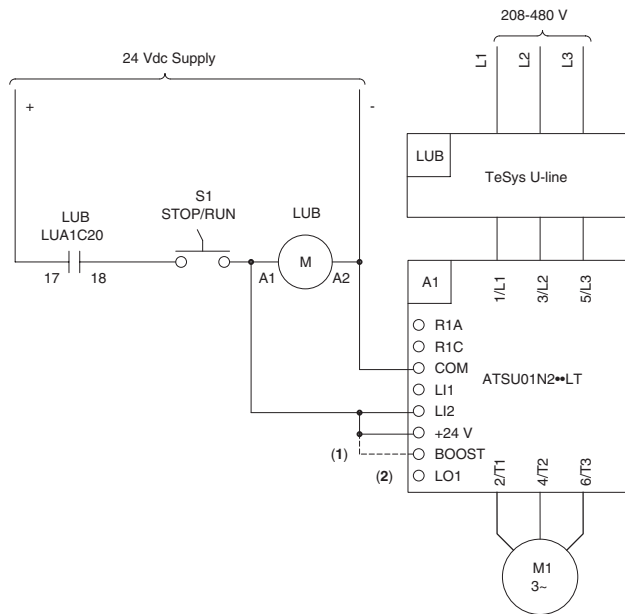

Timing diagram

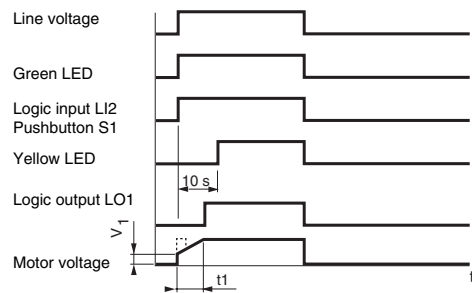

Notes:

- A1:** ATS01 soft start
- LUB:** TeSys U-Line motor starter
- LUA1C20:** Control circuit contact block for TeSys U-Line motor starter
- S1:** Selector switch or maintained pushbutton
- t1:** 1–10 second adjustable starting time
- V1:** Initial motor voltage – adjustable from 30 to 80% of the motor's rated voltage
- (1)** Optional jumper to select boost.
- (2)** See page 6 for L01 wiring recommendations.

Low Power Mini Soft Starts Wiring Diagrams

Altistart® 01 soft start and TeSys® U-Line motor starter combinations

ATSU01N2●●LT

ATS01N2●●LU/QN/RT

Automatic 2-wire control with or without soft stop

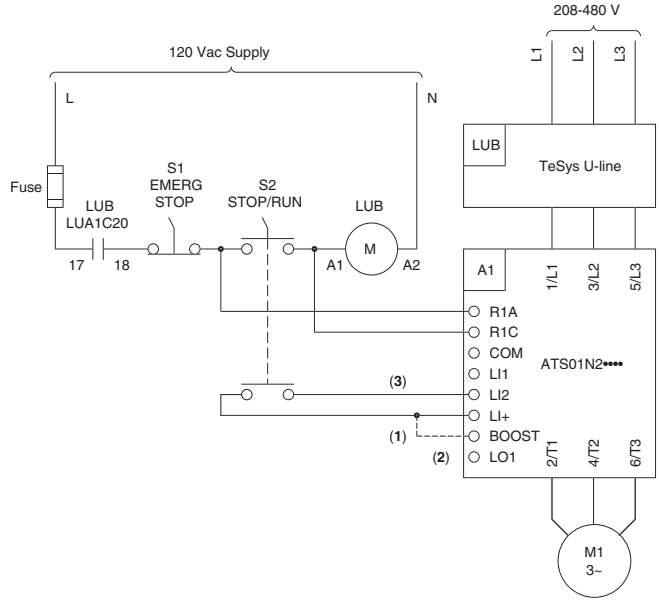
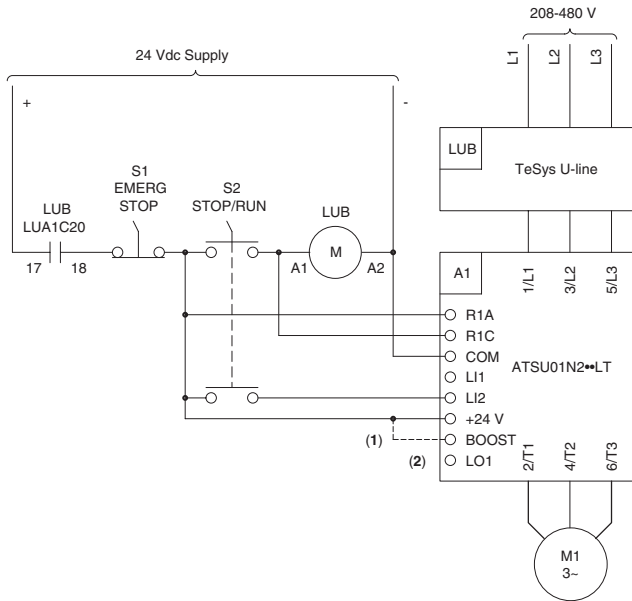

Timing diagram

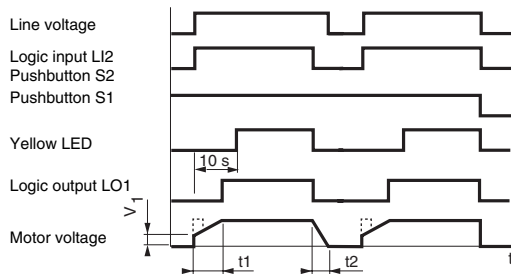

Notes:

- A1:** ATSU01 soft start
- LUB:** TeSys U-Line motor starter
- LUA1C20:** Control circuit contact block for TeSys U-Line motor starter
- S1, S2:** Selector switches or maintained pushbuttons
- t1:** 1–10 second adjustable starting time
- t2:** 1–10 second adjustable stopping time
- V1:** Initial motor voltage – adjustable from 30 to 80% of the motor's rated voltage
- (1)** Optional jumper to select boost.
- (2)** See page 6 for LO1 wiring recommendations.
- (3)** Use shielded cable if control wiring is longer than 3 feet.

Altistart® 01 soft start and TeSys® U-Line motor starter combinations

ATSU01N2●●LT

ATS01N2●●LU/QN/RT

Automatic 3-wire control without soft stop

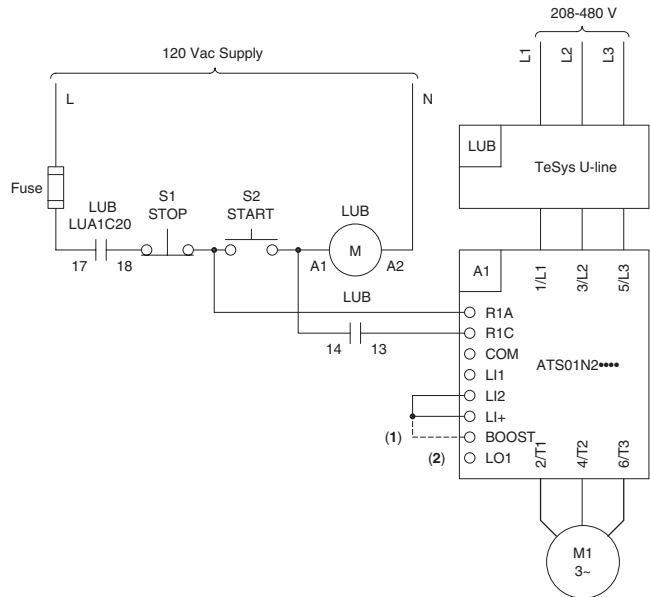
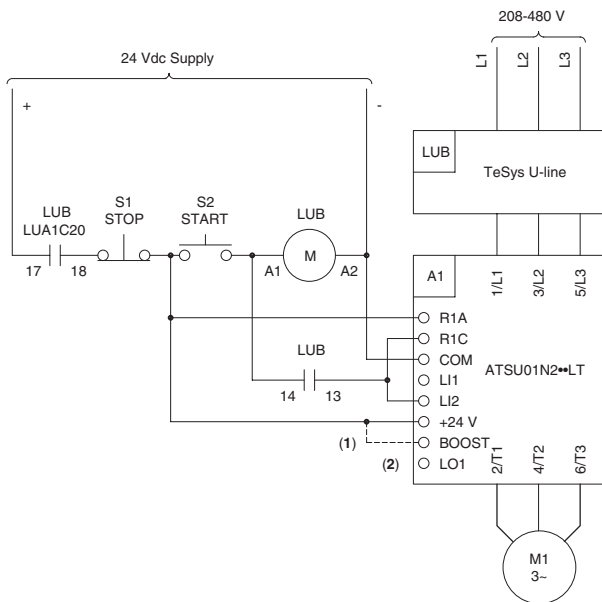

Timing diagram

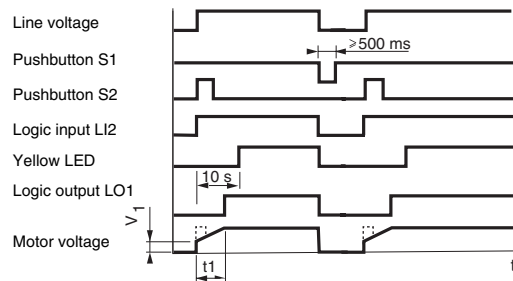

Notes:

- A1:** ATSO1 soft start
- LUB:** TeSys U-Line motor starter
- LUA1C20:** Control circuit contact block for TeSys U-Line motor starter
- S1, S2:** Momentary pushbuttons
- t1:** 1–10 second adjustable starting time
- V1:** Initial motor voltage – adjustable from 30 to 80% of the motor's rated voltage
- (1)** Optional jumper to select boost.
- (2)** See page 6 for LO1 wiring recommendations.

Low Power Mini Soft Starts Wiring Diagrams

Altistart® 01 soft start and TeSys® U-Line motor starter combinations

ATSU01N2●●LT

ATS01N2●●LU/QN/RT

Automatic 3-wire control with soft stop

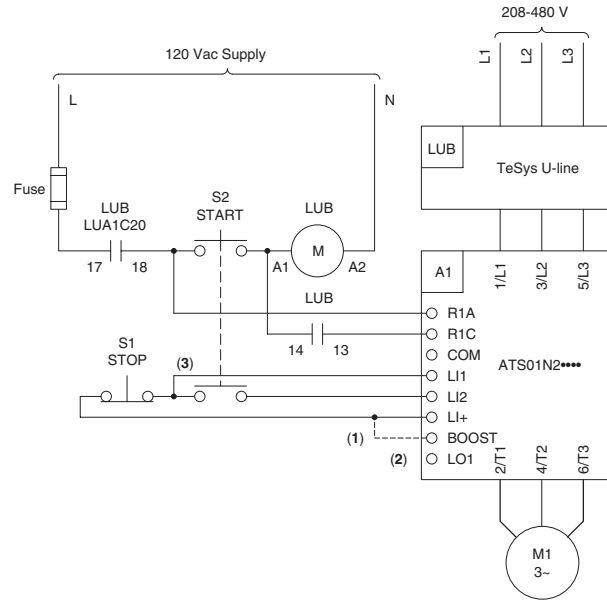
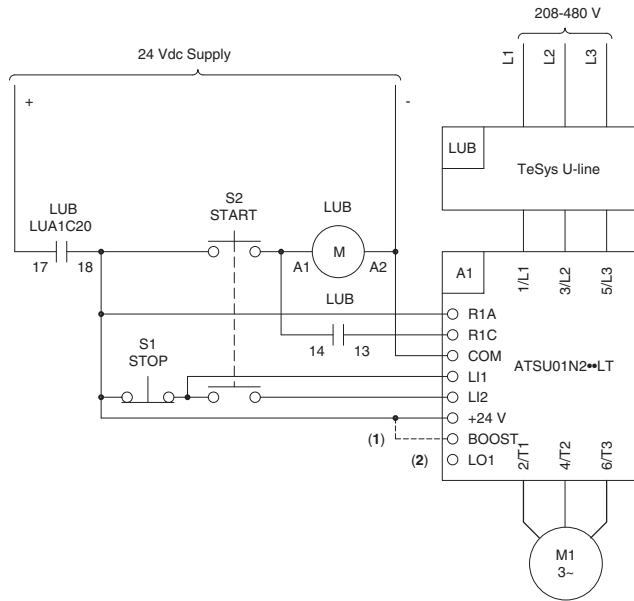

Timing diagram

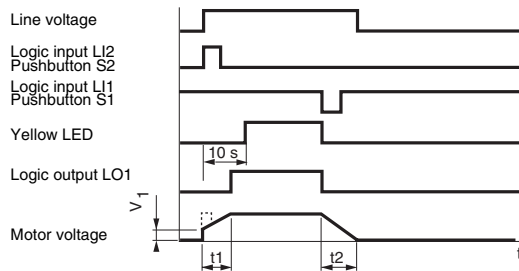

Notes:

- A1:** ATS01 soft start
- LUB:** TeSys U-Line motor starter
- LUA1C20:** Control circuit contact block for TeSys U-Line motor starter
- S1, S2:** Momentary pushbuttons
- t1:** 1–10 second adjustable starting time
- t2:** 1–10 second adjustable stopping time
- V1:** Initial motor voltage – adjustable from 30 to 80% of the motor's rated voltage
- (1)** Optional jumper to select boost.
- (2)** See page 6 for L01 wiring recommendations.
- (3)** Use shielded cable if control wiring is longer than 3 feet.

Altistart® 01 soft start and TeSys® U-Line motor starter combinations

ATSU01N2●●LT

ATS01N2●●LU/QN/RT

Hand-Off-Auto Control with soft stop

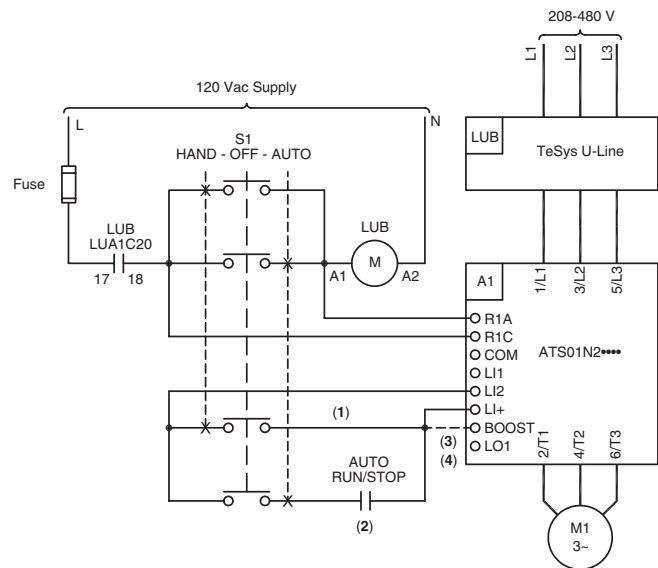
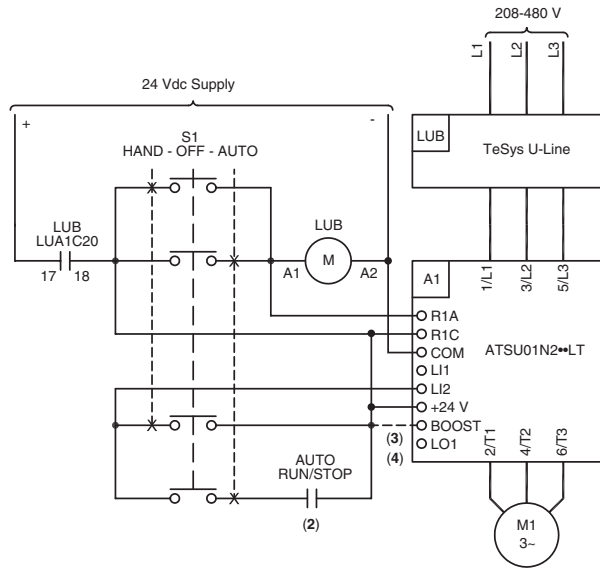

Timing diagram

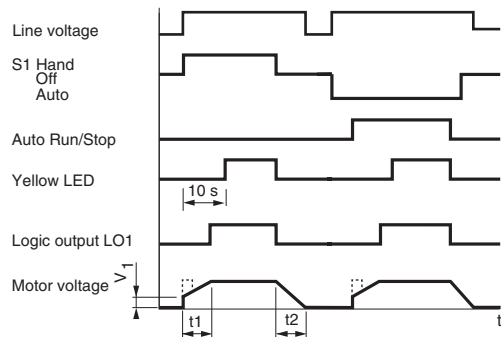

Notes:

- A1:** ATS01 soft start
- LUB:** TeSys U-Line motor starter
- LUA1C20:** Control circuit contact block for TeSys U-Line motor starter
- S1:** Selector switch
- t1:** 1–10 second adjustable starting time
- t2:** 1–10 second adjustable stopping time
- V1:** Initial motor voltage – adjustable from 30 to 80% of the motor's rated voltage
- (1) Use shielded cable if control wiring is longer than 3 feet.
- (2) From automated control system.
- (3) Optional jumper to select boost.
- (4) See page 6 for LO1 wiring recommendations.

Low Power Mini Soft Starts Wiring Diagrams

Altistart® 01 soft start and TeSys® U-Line motor starter combinations

ATSU01N2●●LT

ATS01N2●●LU/QN/RT

Automatic 3-wire control with reversing without soft stop

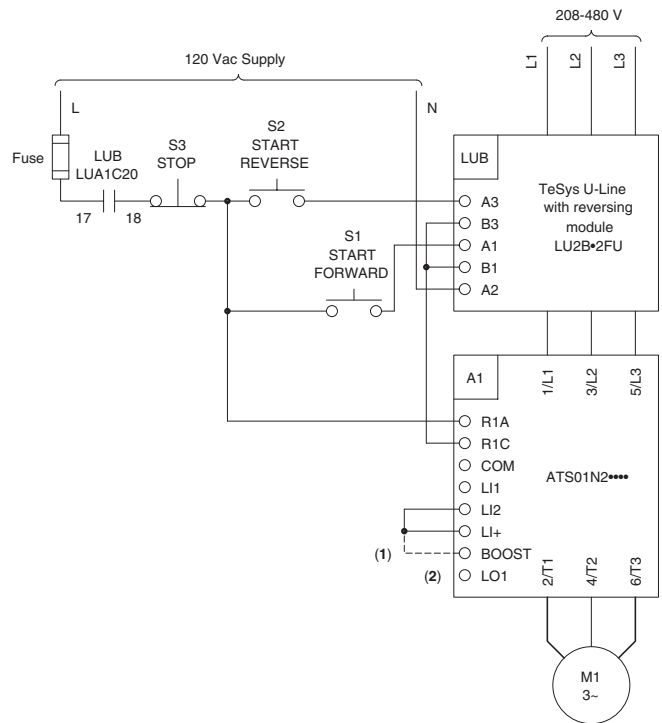
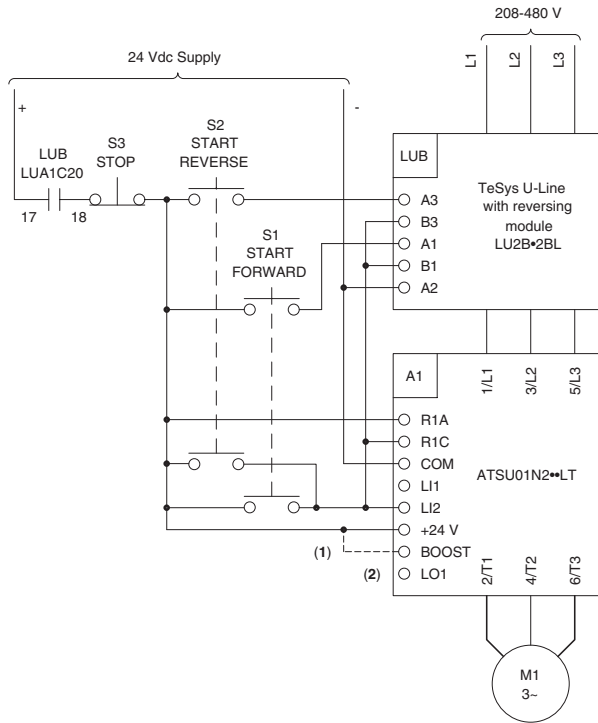

Timing diagram

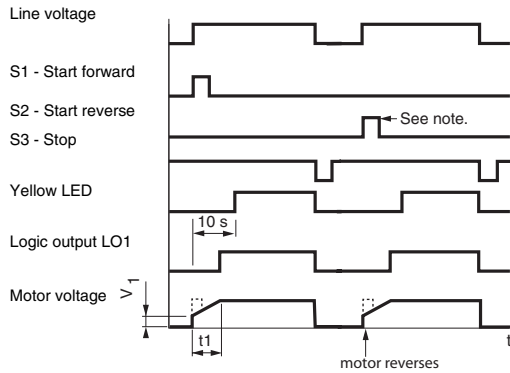

Note: To prevent possible internal damage to the soft start, wait for the motor to stop before changing motor direction.

Notes:

- A1:** ATS01 soft start
- LUB:** TeSys U-Line motor starter
- LUA1C20:** Control circuit contact block for TeSys U-Line motor starter
- S1, S2:** Momentary pushbuttons
- S3:** Momentary pushbutton – must be held for a minimum of 1/2 second
- t1:** 1–10 second adjustable starting time
- V1:** Initial motor voltage – adjustable from 30 to 80% of the motor's rated voltage
- (1)** Optional jumper to select boost.
- (2)** See page 6 for L01 wiring recommendations.

Altistart® 01 soft start and TeSys® U-Line motor starter combinations

ATSU01N2●●LT

ATS01N2●●LU/QN/RT

Automatic 3-wire control with reversing with soft stop

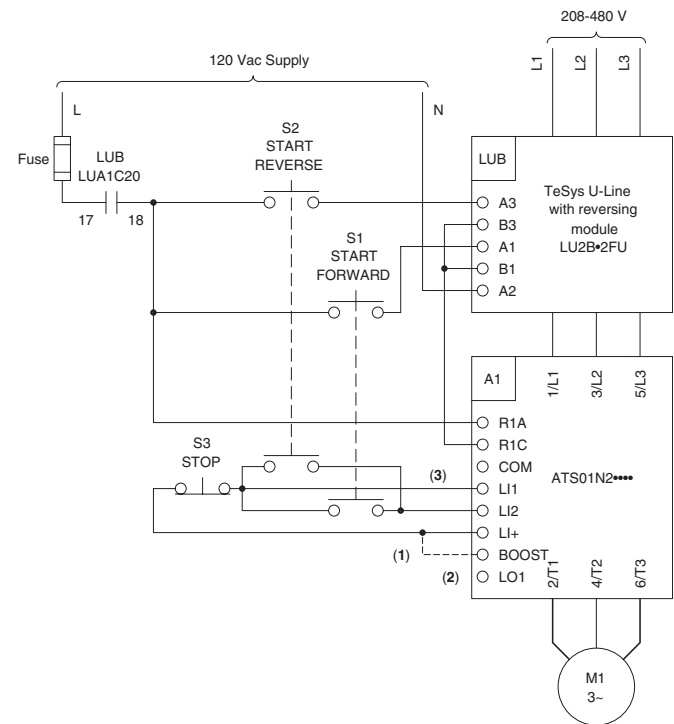
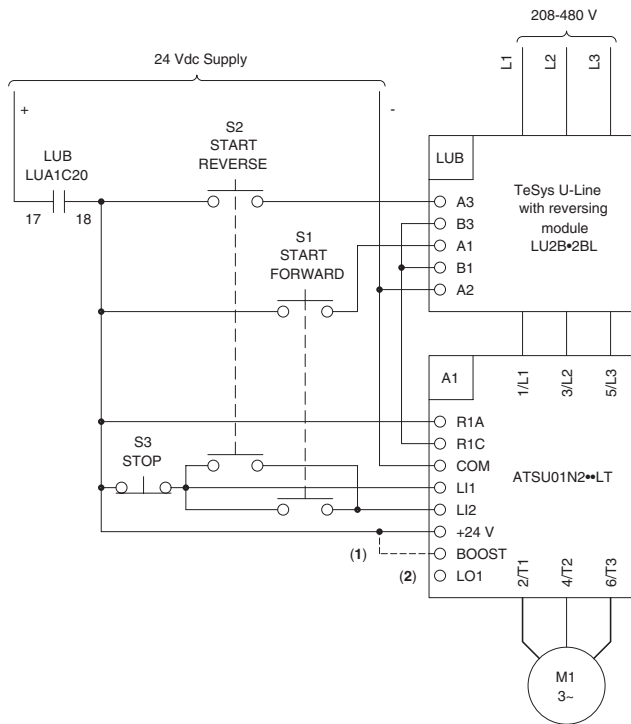

Timing diagram

Line voltage

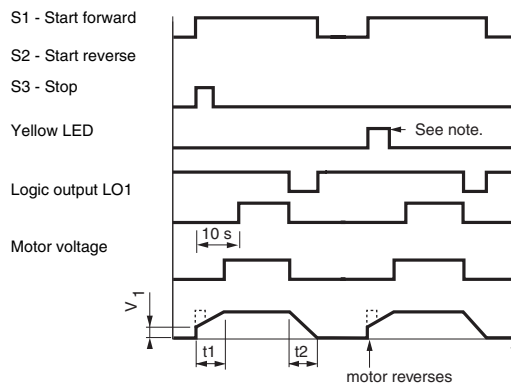

Note: To prevent possible internal damage to the soft start, wait for the motor to stop before changing motor direction.

Notes:

- A1:** ATS01 soft start
- LUB:** TeSys U-Line motor starter
- LUA1C20:** Control circuit contact block for TeSys U-Line motor starter
- S1, S2, S3:** Momentary pushbuttons
- t1:** 1–10 second adjustable starting time
- t2:** 1–10 second adjustable stopping time
- V1:** Initial motor voltage – adjustable from 30 to 80% of the motor's rated voltage
- (1)** Optional jumper to select boost.
- (2)** See page 6 for LO1 wiring recommendations.
- (3)** Use shielded cable if control wiring is longer than 3 feet.

Low Power Mini Soft Starts Wiring Diagrams

Altistart® 01 soft start and TeSys® U-Line motor starter combinations

ATSU01N2●●LT

ATS01N2●●LU/QN/RT

Automatic control with Modbus module with or without soft stop

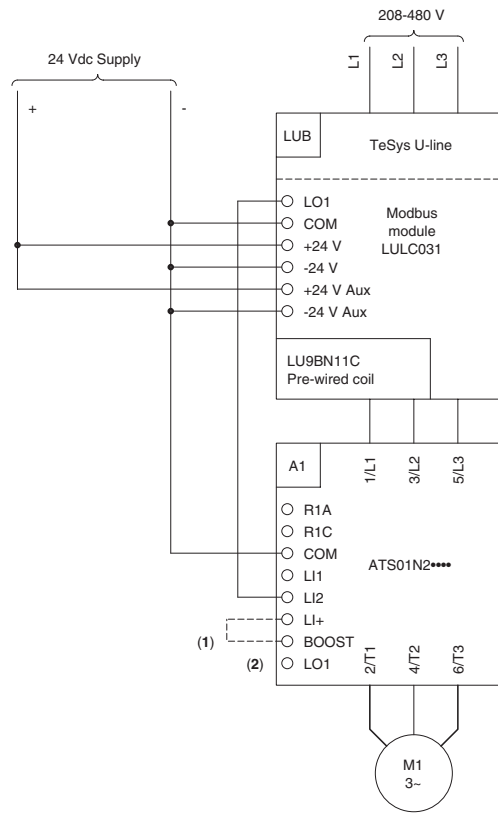
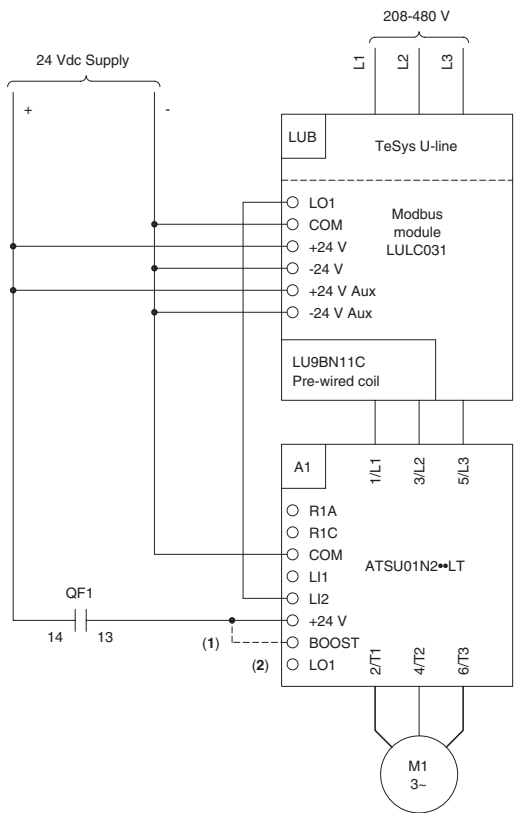

Function	Register	Bit	Value
Powering down U-Line motor starter and ATS01 soft start			
-	704	0	0
Automatic control without soft stop			
Run	700	0	1
Stop	704	0	0
Automatic control with soft stop			
Run	700	0	1
Soft stop	700	0	0

Notes:

- A1:** ATS01 soft start
- LUB:** TeSys U-Line motor starter
- (1)** Optional jumper to select boost.
- (2)** See page 6 for L01 wiring recommendations.

Altistart® 01 soft start and TeSys® U-Line motor starter combinations

ATSU01N2●●LT

ATS01N2●●LU/QN/RT

Automatic control with Modbus module with reversing with or without soft stop

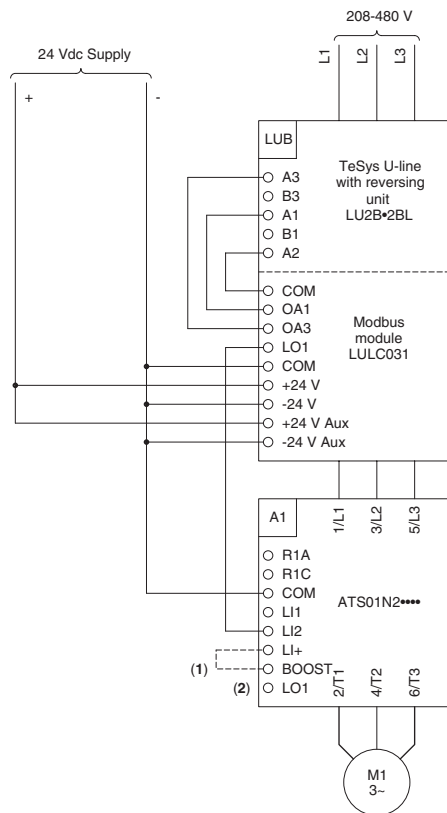
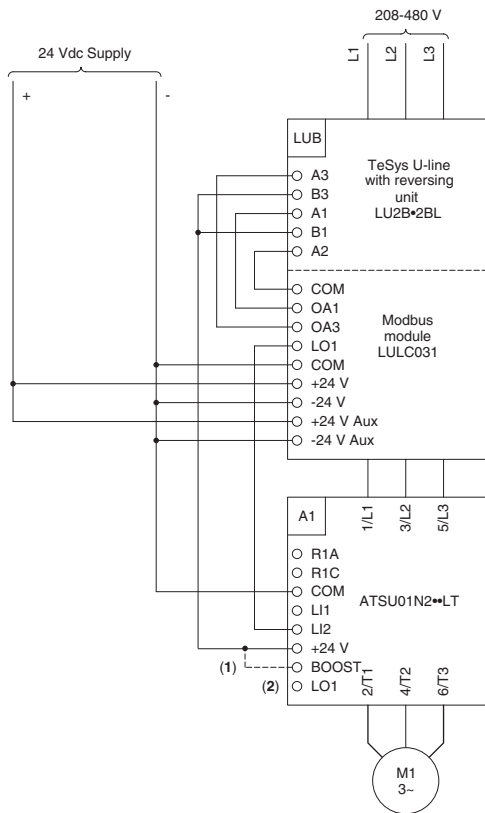

Function	Register	Bit	Value
Powering up U-Line motor starter and ATS01 soft start			
Forward	704	0	1
Reverse	704	1	1
Powering down U-Line motor starter and ATSU soft start			
Forward	704	0	0
Reverse	704	1	0
Automatic control without deceleration			
Run	700	0	1
Stop forward	704	0	0
Stop reverse	704	1	0
Automatic control with deceleration (forward or reverse)			
Run	700	0	1
Soft stop	700	0	0

Notes:

A1: ATS01 soft start

LUB: TeSys U-Line motor starter

(1) Optional jumper to select boost.

(2) See page 6 for L01 wiring recommendations.

Low Power Mini Soft Starts Wiring Diagrams

Altistart® 01 soft start and TeSys® U-Line motor starter combinations

ATSU01N2●●LT

ATS01N2●●LU/QN/RT

Automatic control with AS-Interface communication module without soft stop

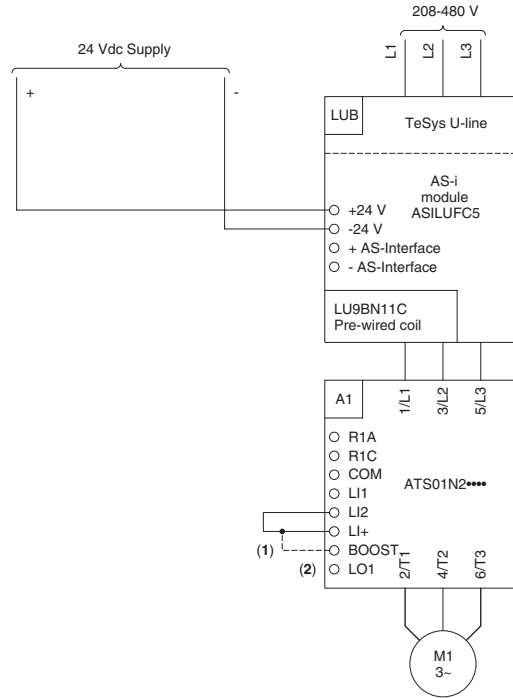
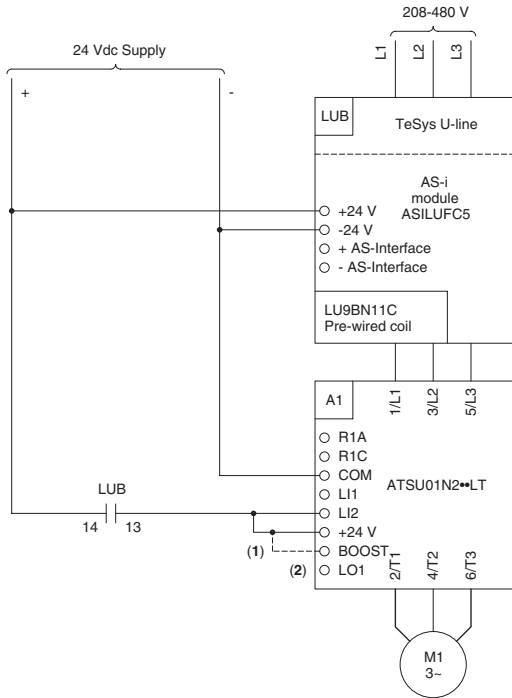

Function	Bit	Value
Power-up and automatic control without soft stop		
Run	D0	1
Stop	D0	0

Notes:

- A1:** ATS01 soft start
- LUB:** TeSys U-Line motor starter
- (1) Optional jumper to select boost.
- (2) See page 6 for L01 wiring recommendations.

Altistart® 01 soft start and TeSys® U-Line motor starter combinations

ATSU01N2●●LT

ATS01N2●●LU/QN/RT

Automatic control with AS-Interface communication module with reversing without soft stop

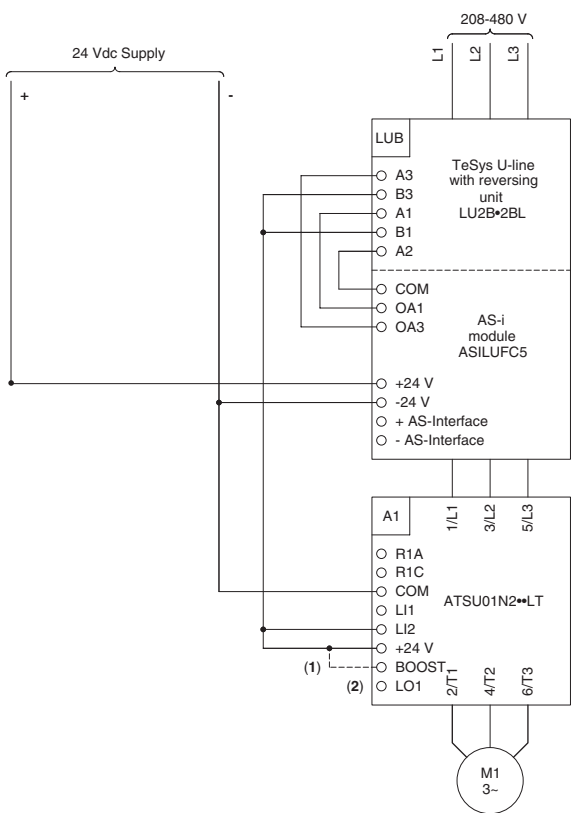

Function	Bit	Value
Power-up and automatic control without soft stop		
Run forward	D0	1
Stop	D0	0
Run reverse	D1	1
Stop	D1	0

Notes:

- A1:** ATS01 soft start
- LUB:** TeSys U-Line motor starter
- (1)** Optional jumper to select boost.
- (2)** See page 6 for L01 wiring recommendations.

Low Power Mini Soft Starts Wiring Diagrams

ATS01N2●●LU/QN/RT soft start with GV manual starter, or other motor starter

Group motor installation

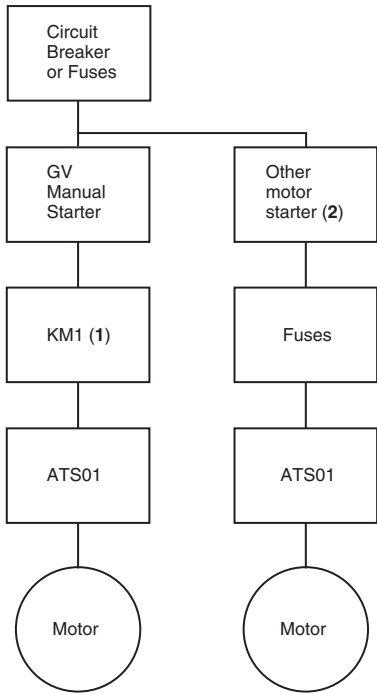

Non-group motor installation

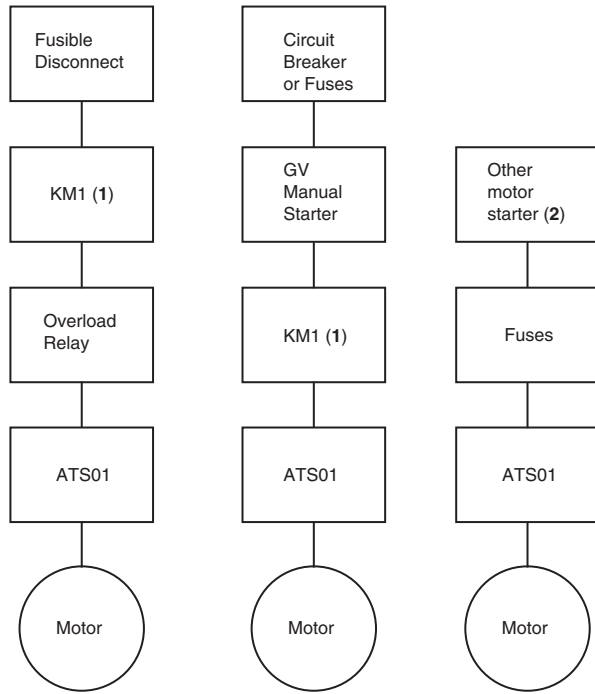

- (1) Optional contactor for line isolation and remote control.
 (2) Other motor starters must provide motor overload protection.

Note: Observe national and local electrical codes when selecting the circuit breaker and other motor starters. See the selection table on page 12 for recommendations on the following components:

- ATS01 soft start
- GV manual starter
- KM1 isolation contactor
- Fuses
- Overload relay

ATS01N2●●LU/QN/RT soft start with GV manual starter, or other motor starter

Manual control without soft stop

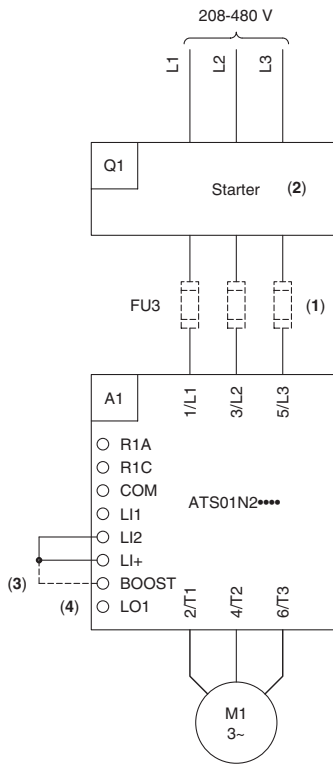

Timing Diagram

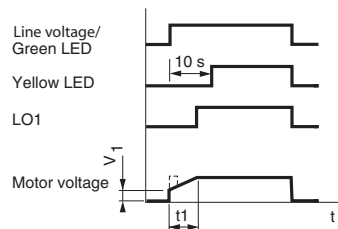

Notes:

- A1:** ATS01 soft start
- FU3:** Fast-acting UL Listed Class J fuse
- Q1:** Manual motor starter or disconnect switch
- t1:** 1–10 second adjustable starting time
- V1:** Initial motor voltage – adjustable from 30 to 80% of the motor's rated voltage
- (1) Fuses are not required if device Q1 is a GV manual motor starter installed per local and national electrical codes.
- (2) Overload protection required if not included in device Q1.
- (3) Optional jumper to select boost.
- (4) See page 6 for L01 wiring recommendations.

Low Power Mini Soft Starts Wiring Diagrams

ATS01N2●●LU/QN/RT soft start with GV manual starter, fusible disconnect, or other motor starter

Hand-Off-Auto control with soft stop and isolation contactor

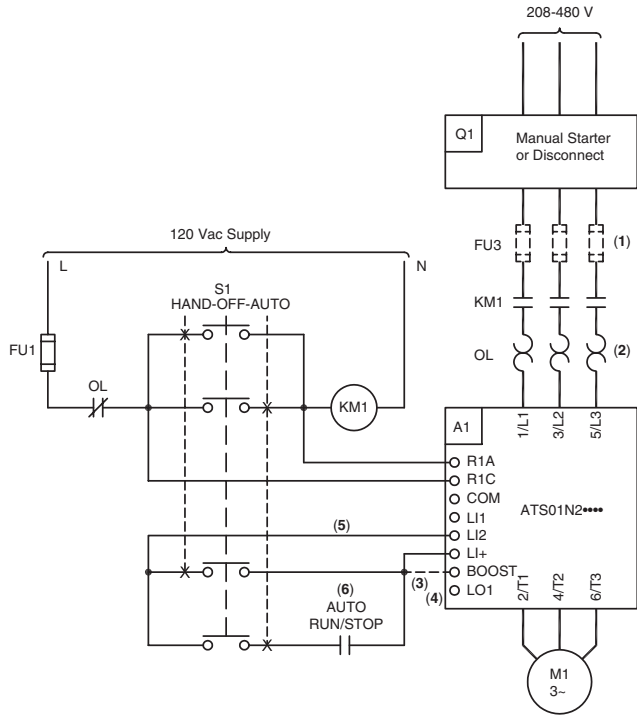

Timing Diagram

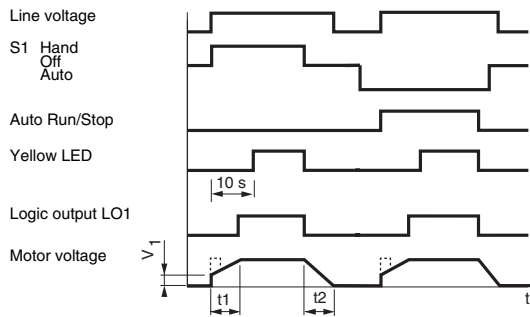

Notes:

- A1:** ATS01 soft start
- FU1:** Control circuit fuse
- FU3:** Fast-acting UL Listed Class J fuse
- KM1:** Isolating contactor
- OL:** Overload relay
- Q1:** Manual motor starter or disconnect switch
- S1:** Selector switch
- t1:** 1–10 second adjustable starting time
- t2:** 1–10 second adjustable stopping time
- V1:** Initial motor voltage – adjustable from 30 to 80% of the motor's rated voltage
- (1) Fuses FU3 are not required if device Q1 is a GV manual motor starter installed per local and national electrical codes.
- (2) Overload protection required if not included in device Q1.
- (3) Optional jumper to select boost.
- (4) See page 6 for LO1 wiring recommendations.
- (5) Use shielded cable if control wiring is longer than 3 feet.
- (6) From automated control system.

ATS01N2●●LU/QN/RT soft start with GV manual starter, fusible disconnect, or other motor starter

Hand-Off-Auto control with soft stop without isolation contactor

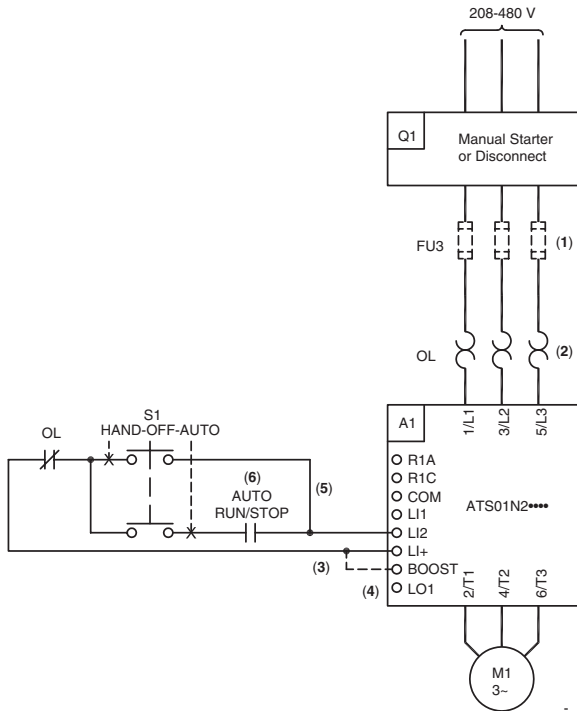

Timing Diagram

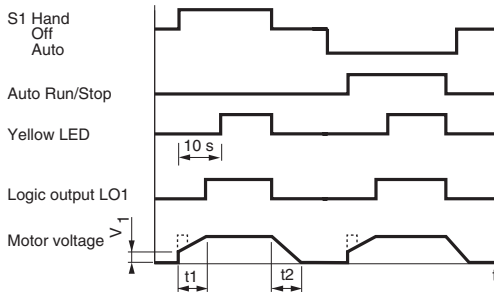

Notes:

- A1:** ATS01 soft start
- FU3:** Fast-acting UL Listed Class J fuse
- OL:** Overload relay
- Q1:** Manual motor starter or disconnect switch
- S1:** Selector switch
- t1:** 1–10 second adjustable starting time
- t2:** 1–10 second adjustable stopping time
- V1:** Initial motor voltage – adjustable from 30 to 80% of the motor's rated voltage
- (1) Fuses FU3 are not required if device Q1 is a GV manual motor starter installed per local and national electrical codes.
- (2) Overload protection required if not included in device Q1.
- (3) Optional jumper to select boost.
- (4) See page 6 for LO1 wiring recommendations.
- (5) Use shielded cable if control wiring is longer than 3 feet.
- (6) From automated control system.

Low Power Mini Soft Starts Wiring Diagrams

ATS01N2●●LU/QN/RT soft start with GV manual starter, fusible disconnect, or other motor starter

Automatic control (2 or 3-wire) with or without soft stop

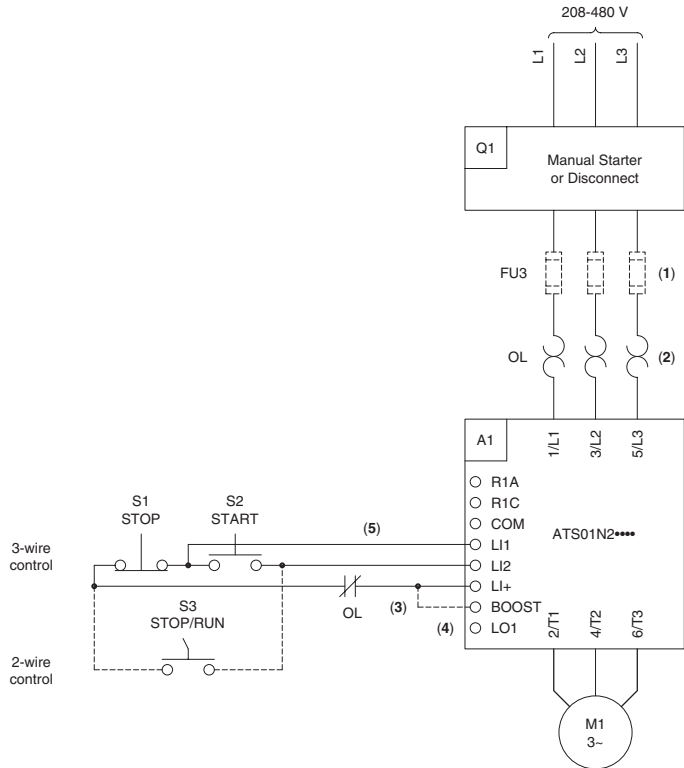

Timing Diagram

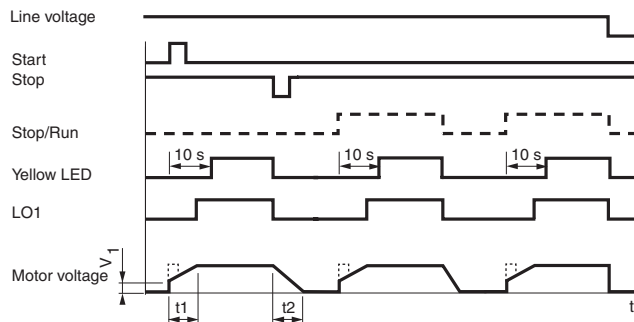

Notes:

- A1:** ATS01 soft start
- FU3:** Fast-acting UL Listed Class J fuse
- OL:** Overload relay
- Q1:** Manual motor starter or disconnect switch
- S1, S2:** Momentary pushbuttons
- S3:** Selector switch
- t1:** 1–10 second adjustable starting time
- t2:** 1–10 second adjustable stopping time
- V1:** Initial motor voltage – adjustable from 30 to 80% of the motor's rated voltage
- (1) Fuses FU3 are not required if device Q1 is a GV manual motor starter installed per local and national electrical codes.
- (2) Overload protection required if not included in device Q1.
- (3) Optional jumper to select boost.
- (4) See page 6 for LO1 wiring recommendations.
- (5) Use shielded cable if control wiring is longer than 3 feet.

ATS01N2●●LU/QN/RT soft start with GV manual starter, fusible disconnect, or other motor starter

Automatic 3-wire control with isolation contactor without soft stop

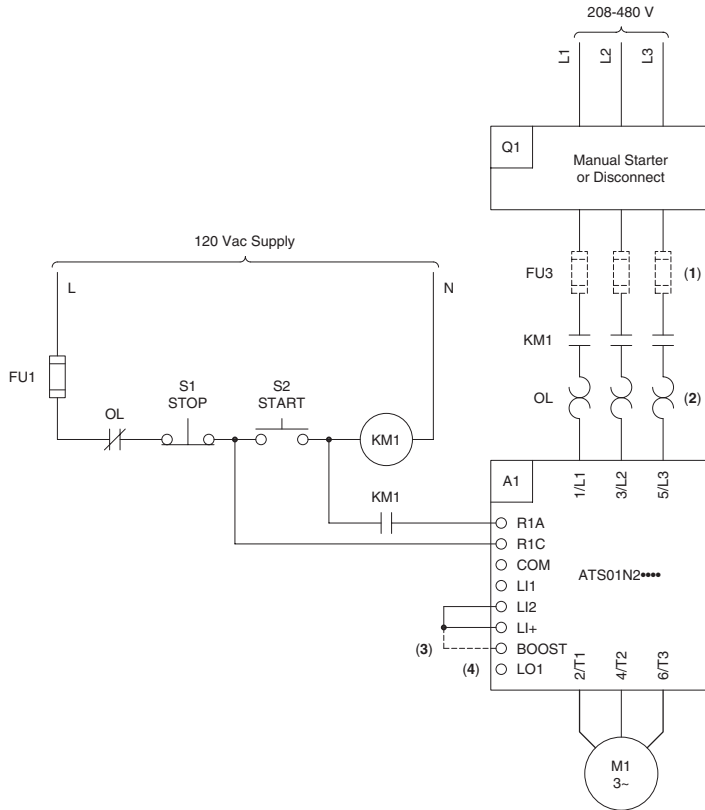

Timing Diagram

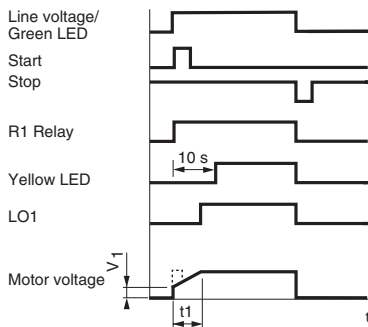

Notes:

- A1:** ATS01 soft start
 - FU1:** Control circuit fuse
 - FU3:** Fast-acting UL Listed Class J fuse
 - KM1:** Isolation contactor
 - OL:** Overload relay
 - Q1:** Manual motor starter or disconnect switch
 - S1, S2:** Momentary pushbuttons
 - t1:** 1–10 second adjustable starting time
 - V1:** Initial motor voltage – adjustable from 30 to 80% of the motor's rated voltage
- (1) Fuses FU3 are not required if device Q1 is a GV manual motor starter installed per local and national electrical codes.
- (2) Overload protection required if not included in device Q1.
- (3) Optional jumper to select boost.
- (4) See page 6 for LO1 wiring recommendations.

Low Power Mini Soft Starts Wiring Diagrams

ATS01N2●●LU/QN/RT soft start with GV manual starter, fusible disconnect, or other motor starter

Automatic 3-wire control with isolation contactor with or without soft stop

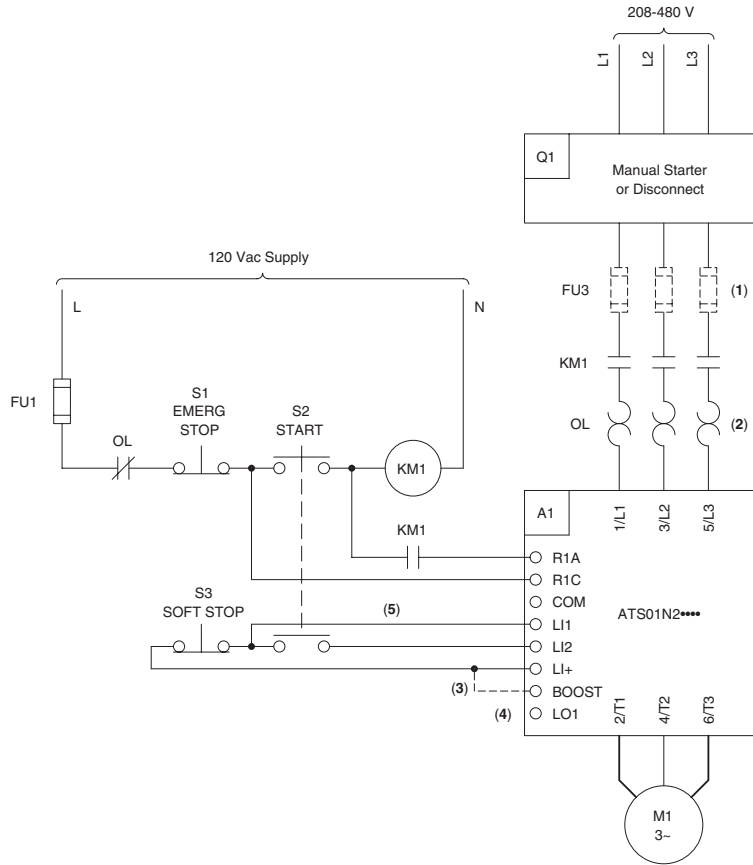

Timing Diagram

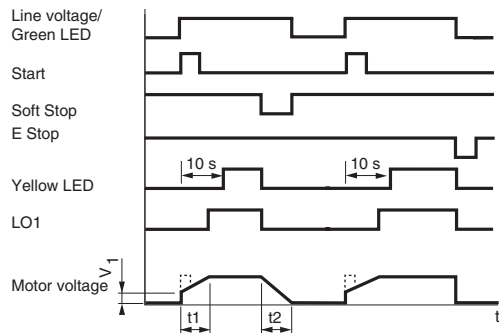

Notes:

- A1:** ATS01 soft start
- FU1:** Control circuit fuse
- FU3:** Fast-acting UL Listed Class J fuse
- KM1:** Isolation contactor
- OL:** Overload relay
- Q1:** Manual motor starter or disconnect switch
- S1, S2, S3:** Momentary pushbuttons
- t1:** 1–10 second adjustable starting time
- t2:** 1–10 second adjustable stopping time
- V1:** Initial motor voltage – adjustable from 30 to 80% of the motor's rated voltage
- (1)** Fuses FU3 are not required if device Q1 is a GV manual motor starter installed per local and national electrical codes.
- (2)** Overload protection required if not included in device Q1.
- (3)** Optional jumper to select boost.
- (4)** See page 6 for L01 wiring recommendations.
- (5)** Use shielded cable if control wiring is longer than 3 feet.

ATS01N2●●LU/QN/RT soft start with GV manual starter, fusible disconnect, or other motor starter

Automatic 3-wire control with reversing with or without soft stop

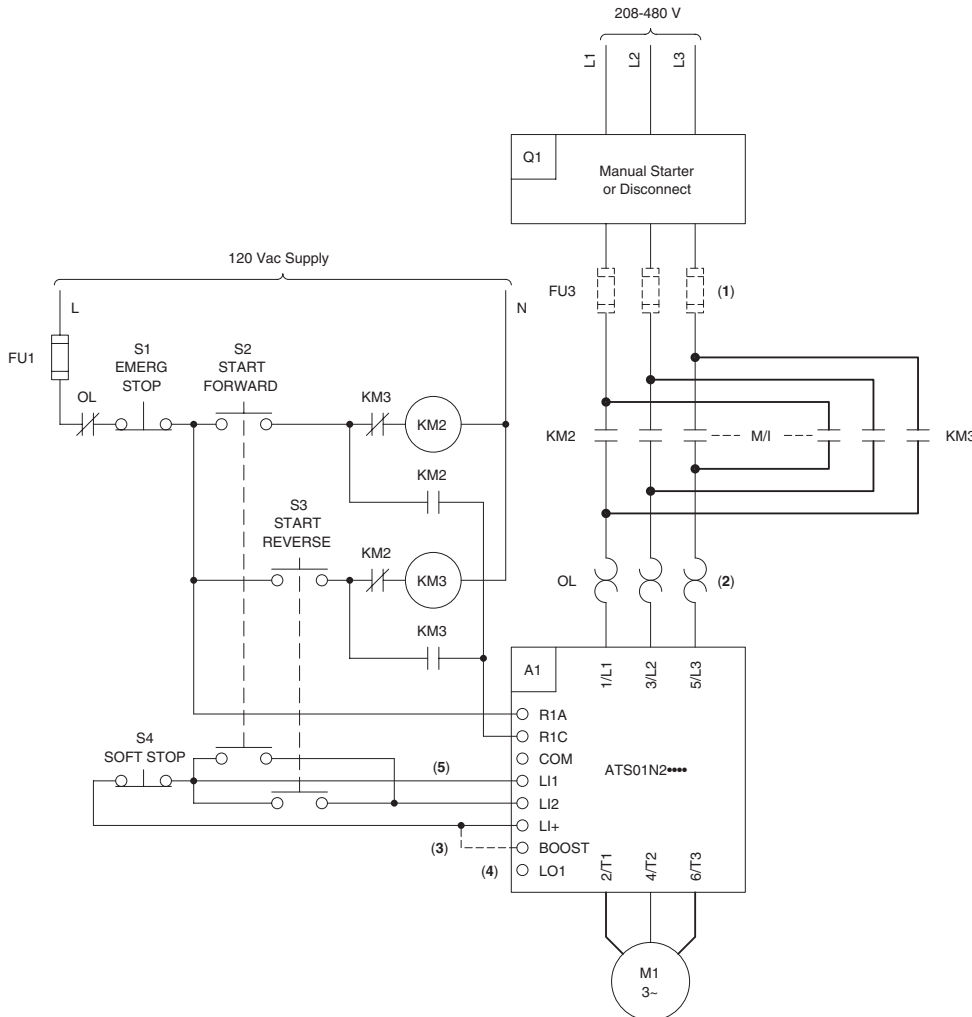

Timing Diagram

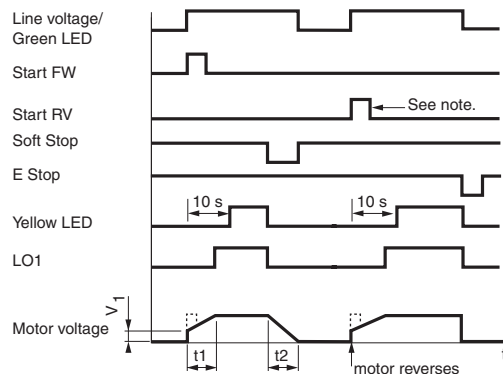

Note: To prevent possible internal damage to the soft start, wait for the motor to stop before changing motor direction.

Notes:

- A1:** ATS01 soft start
- FU1:** Control circuit fuse
- FU3:** Fast-acting UL Listed Class J fuse
- KM2, KM3:** Reversing contactor
- OL:** Overload relay
- Q1:** Manual motor starter or disconnect switch
- S1, S2, S3, S4:** Momentary pushbuttons
- t1:** 1–10 second adjustable starting time
- t2:** 1–10 second adjustable stopping time
- V1:** Initial motor voltage – adjustable from 30 to 80% of the motor's rated voltage
- (1)** Fuses FU3 are not required if device Q1 is a GV manual motor starter installed per local and national electrical codes.
- (2)** Overload protection required if not included in device Q1.
- (3)** Optional jumper to select boost.
- (4)** See page 6 for LO1 wiring recommendations.
- (5)** Use shielded cable if control wiring is longer than 3 feet.

Overview:
pages 3–6

Characteristics:
pages 7–9

Dimensions:
page 10

Selection:
pages 11–12

Low Power Mini Soft Starts

High Power Mini Soft Starts Overview

Overview

The high power portion of the Altistart® 01 (ATS01) family of soft starts extends the product range from 32 to 85 A (20 to 60 hp at 460 V).

The high power ATS01 soft starts are sized for heavy duty applications with:

- starting and stopping times up to 25 seconds
- ambient operating temperatures up to 130 °F (55 °C) without derating
- altitudes up to 6600 feet (2000 m) without derating

This range of the ATS01 family is compatible with most common industrial and commercial 3-phase motor voltages (208 V to 575 V) and 110 V control power.

The ATS01 was designed to meet IEC 60947-4-2, the internationally accepted standard defining soft starts. It is UL Listed, CSA Certified, and CE Marked.

As with the low power ATS01N2 models, the four high power models are designed to:

- improve the performance of asynchronous motors by allowing them to start and stop gradually, smoothly, and in a controlled manner.
- limit starting torque and greatly reduce the current inrush experienced with other motor starting methods. They are ideal for applications that do not require high starting torque.

The high power ATS01 soft starts control two phases of the AC voltage supplying the motor to limit starting torque and current.

The transitionless starting method of the ATS01 soft start avoids the torque surges associated with electromechanical reduced voltage starting methods.

Using the ATS01 soft start avoids the damage and expense associated with full voltage starting.

In addition, these soft starts limit the power demands on an installation's electrical network, eliminating brown out conditions and the nuisance tripping of sensitive electrical devices caused by the starting of larger motors.

The ATS01 soft start is ideal for applications powered by generators. Soft starting a motor reduces the peak demands on the supplying generator, freeing generator capacity for other needs or reducing the generator size needed for the installation.

Integration is simple with standard 2 or 3-wire control, isolation contactor control, and DIN rail mounting.

Description

The Altistart 01 high power mini soft start is equipped with:

- 1 yellow LED (1) that illuminates after the soft start's voltage ramp is complete, the internal shorting contactor has closed, and the motor is up to speed
- 1 green LED (2) to indicate that soft start power is on
- under a door (3) that can be sealed to discourage unauthorized adjustment
 - a potentiometer to set the starting time
 - a potentiometer to set the stopping time
 - a potentiometer to set the initial voltage applied to the motor when starting begins
- integrated control terminals (4)
- pass-through power wiring terminals (5)

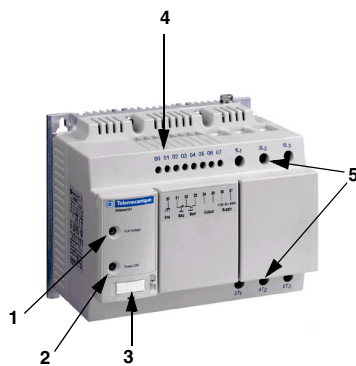

High Power Mini Soft Starts Functions

Altistart® 01 soft start functions

■ 2-wire control

The start and stop commands are provided by a single control input. Wire the ON/OFF switch across terminals 01 and 03. As soon as terminal 01 is connected to terminal 03, the starting process begins. As soon as the connection between terminals 01 and 03 is opened, the stopping process begins. No connection to terminal 02 is required.

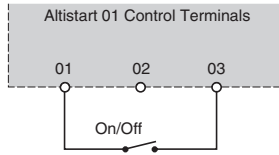

Wiring diagram for 2-wire control

■ 3-wire control

The start and stop commands are provided by two different control inputs. Wire a N.C. Stop switch across terminals 01 and 02. Wire a N.O. Start switch between terminals 02 and 03. While the connection between terminals 01 and 02 is maintained, a momentary connection between terminals 02 and 03 initiates the motor starting process. Momentarily opening the connection between terminals 01 and 02 initiates motor stopping. To issue a second start command, reconnect 01 to 02 and momentarily connect 02 to 03.

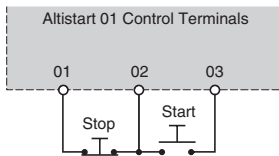

Wiring diagram for 3-wire control

■ Starting and stopping times

The ATS01 soft start controls the starting and stopping time of the motor by ramping the applied motor voltage up and down. The starting and stopping voltage ramp times can be adjusted from 1 to 25 seconds by means of two potentiometers under the protective plastic door.

Since the actual motor starting and stopping times are dependent on the level of the applied load, the scale on the front of the ATS01 soft start is calibrated from A to E rather than from 1 to 25 seconds, with A being the shortest time and E being the longest time.

The starting voltage ramp begins at the AC line voltage level set by the Initial Voltage adjustment. See the diagram below for more detail. See page 35 for more information about Initial Voltage.

Note: The ATS01 soft start is internally bypassed at the end of the time set by the start time adjustment. If the motor is not up to speed by that time (due to a heavy load), the internal contactor can be damaged, requiring replacement of the soft start.
SET THE START TIME AT A LEVEL ACHIEVABLE WITH THE MOTOR AT ITS HIGHEST LOAD LEVEL.

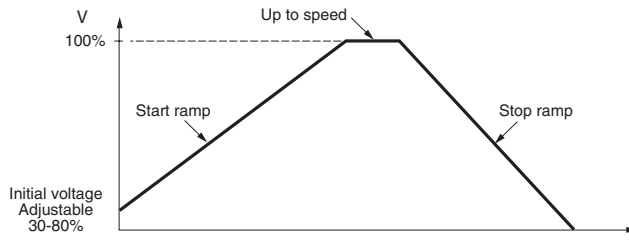

Voltage start and stop ramps, initial voltage, and up to speed

High Power Mini Soft Starts Functions

- **Initial (or starting) voltage**

The initial voltage applied to the motor (the level at which the voltage ramp begins) can be adjusted by a potentiometer under the protective plastic door. The initial voltage level can be adjusted from approximately 30 to 80% of the AC line voltage. Since the resultant motor torque varies in proportion to the square of the applied voltage (see the diagram on page 6), the scale on the face of the Altistart® 01 is calibrated from A to E rather than from 30 to 80%, with A being the lowest level and E being the highest level. A lower setting will reduce motor current and torque during starting. Set this level to the minimum required that will result in motor rotation immediately after a start command.
- **The Altistart 01 soft start provides a N.O. relay contact to indicate either that it has faulted or that it has stopped running the motor.** The normally-open contact between terminals 04 and 05 closes upon a run command. The relay contact opens under either one of the following two conditions:
 - the contact opens instantly when the soft start experiences a fault condition.
 - the contact opens when the motor voltage reaches zero after a stop command.

This information can be used to sequence a contactor if both line isolation and soft stop are needed in the same application.
- **Motor up to speed**

The ATS01 high power soft start models offer an optional snap-on contact block (N.O. and N.C. contacts) to indicate that the starting voltage ramp is complete and the motor is up to speed. To receive this optional relay contact with the ATS01 soft start, order one of part number LAD8N11 for each soft start.
- **DIN rail mounting**

ATS01 models ATS01N230LY and ATS01S44LY can be DIN rail mounted by means of an adapter kit. Order one optional DIN rail mounting kit (part number VY1H4101) for each soft start.

High Power Mini Soft Starts

Characteristics

Environment

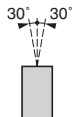
Type of starter	ATS01N2●●LY	
Conformity to standards	Altistart® 01 soft starts conform to the strictest international standards and recommendations relating to electrical industrial control devices, in particular the standard IEC 60947-4-2.	
Electromagnetic compatibility EMC		
Conducted and radiated emissions	CISPR 11 level B, IEC 60947-4-2, level B	
Harmonics	IEC 61000-3-2, IEC 61000-3-4	
EMC immunity	EN 50082-2, EN 50082-1	
Electrostatic discharge	IEC 61000-4-2 level 3	
Immunity to radiated radio-frequency electromagnetic field	IEC 61000-4-3 level 3	
Immunity to electrical transients	IEC 61000-4-4 level 4	
Surge immunity	IEC 61000-4-5 level 3	
Immunity to conducted interference caused by radio-electrical fields	IEC 61000-4-11	
Immunity to voltage disturbances	IEC 61000-4-6 level 3	
Damped oscillating waves	IEC 61000-4-12 level 3	
CE marking	The soft starts are CE marked on the basis of European directives governing low voltage (72/73/EEC) and EMC (89/336/EEC).	
Product certification	UL and CSA	
Degree of protection	IP20 on front panel	
Degree of pollution	3 (conforming to IEC 60664-1 and UL508)	
Vibration resistance	2 gn	
Shock resistance	8 gn for 11 ms conforming to IEC 60068-2-27	
Relative humidity	5–95% without condensation or dripping water, conforming to IEC 60068-2-3	
Ambient temperature around the unit	Storage	- 25 to + 70 °C (-13 to +158 °F) conforming to IEC 60947-4-2
	Operation	0 to + 55 °C (32 to +131 °F)
Maximum operating altitude	2000 m (6600 ft) without derating Above this, derate the current by 0.5% per additional 100 m (330ft).	
Side-by-side mounting	No gap between soft starts is required	
Operating position Maximum permanent angle in relation to a vertical mounting position		

Electrical characteristics

Type of starter	ATS01N2●●LY				
Category of use	Conforming to IEC 60947-4-2	AC-53b			
Rated AC supply voltage	3-phase only	208–690 Vac			
AC line voltage tolerance		-15% to +10%			
Frequency		50 or 60 Hz ± 5%			
Output voltage		Maximum 3-phase voltage equal to AC supply voltage.			
Control supply voltage		110 Vac ± 10% (20 VA)			
Rated operating current		32, 44, 72, and 85 A			
Adjustable starting time		1–25 s			
Adjustable deceleration time		1–25 s			
Starting voltage		30–80% of motor's rated voltage			
Type of starter	ATS01N2	30LY	44LY	72LY	85LY
Power dissipated	At full load at the end of starting	22 W	22 W	23 W	23 W
	During starting and stopping at 3 times the rated operating current	184 W	268 W	436 W	514 W
Type of starter	ATS01N2●●LY				
	Starting time at 3 times the rated operating current	1 s	12 s		
	Max. number of cycles per hour	360	30		

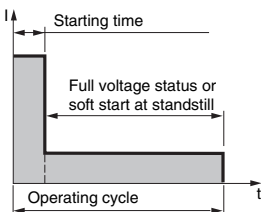

ATS01 Control Terminals

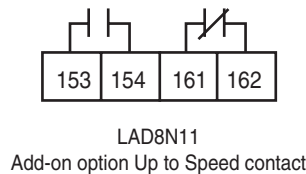
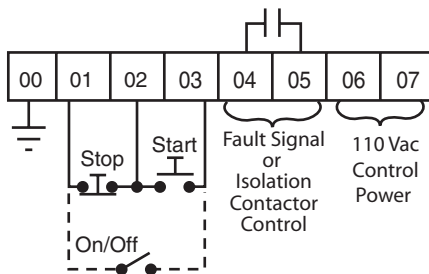

Control Terminal Definitions	
06, 07, 00 Control power, Ground	110 Vac ± 10% (20 VA)
01, 02, 03 Control inputs – start and stop Not rated for 110 Vac.	
04, 05 Relay output Fault signal and isolation contactor control Relay contact is open when soft start is not running or when it is faulted.	Normally-open (N.O.) contact Utilization category AC15 and DC13 Minimum switching capacity: 10 mA at 17 Vdc Max. switching capacity on inductive load: 6 A at 250 Vac Max. operating voltage 250 Vac
153, 154, 161, 162 Relay output (optional) Motor up to speed signal Relay changes state when soft start ramp is complete and motor is up to speed.	Normally-open (N.O.) and Normally-closed (N.C.) contact Utilization category AC14, AC15 and DC13 Minimum switching capacity: 5 mA at 17 Vdc Rated insulation voltage: 600 V Rated current ≤104 °F (40 °C): 10 A Rated making capacity: 140 Aac, 250 Adc Tightening torque: 10.6 in-lb (1.2 Nm)
LED signalling	
Green LED	Soft start power on
Yellow LED	Voltage ramp complete, motor up to speed

High Power Mini Soft Starts Characteristics

Connections (Maximum connection capacity and tightening torque)

Power circuit		Connection onto Ø 4 mm screw terminals	
Stranded wire without cable end	1 conductor	6–25 mm ²	(10–4 AWG)
	2 conductors	6–25 mm ²	(10–4 AWG)
Stranded wire with cable end	1 conductor	4–25 mm ²	(12–4 AWG)
	2 conductors	4–16 mm ²	(12–6 AWG)
Solid wire	1 conductor	6–35 mm ²	(10–2 AWG)
	2 conductors	6–25 mm ²	(10–4 AWG)
Tightening torque		5 N•m	(3.7 ft-lb)
Control circuit		Screw connector	
Stranded wire without cable end	1 conductor	0.75–1.5 mm ²	(18–16 AWG)
	2 conductors	0.75–1.5 mm ²	(18–16 AWG)
Stranded wire with cable end	1 conductor	0.75–1.5 mm ²	(18–16 AWG)
	2 conductors	0.75–1.5 mm ²	(18–16 AWG)
Solid wire	1 conductor	0.75–1.5 mm ²	(18–16 AWG)
	2 conductors	0.75–1.5 mm ²	(18–16 AWG)
Tightening torque		0.7 N•m	(6.2 in-lb)
Ground connection		Tinned connector. Attach using 6 mm screw.	

High Power Mini Soft Starts Dimensions

ATS01N230LY, ATS01N244LY

For DIN rail mounting, order adapter plate VY1H4101 (1)

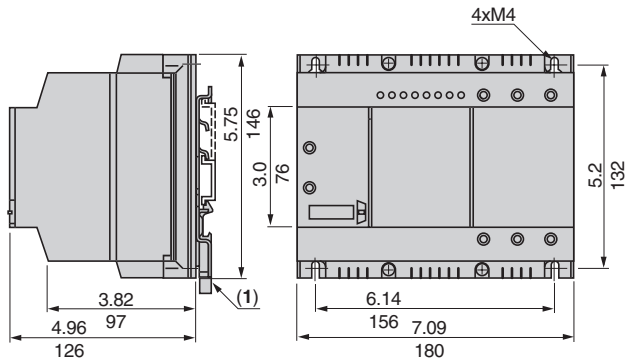

ATS01N272LY, ATS01N285LY

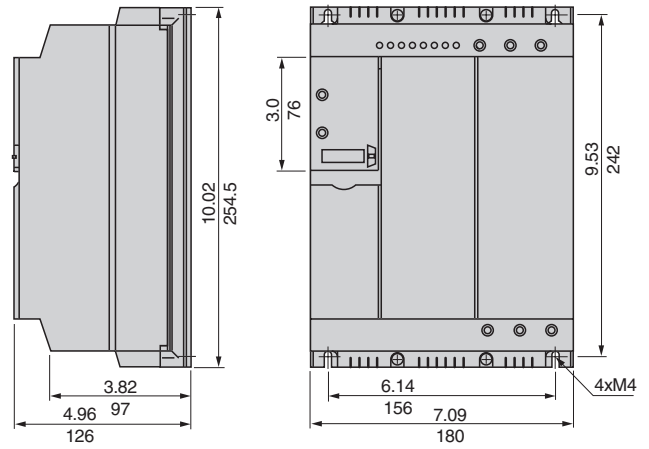

Dimensions: $\frac{\text{in.}}{\text{mm}}$

High Power Mini Soft Starts Selection

Motor hp		ATS01 Soft Start	GV Manual Starter	Isolation Contactor	Fast Acting Class J Fuses (1)	Overload Relay (2)
200/208 V	230/240 V					
	10	ATS01N230LY	GV2ME32	LC1D32	90 A	LRD32
10		ATS01N244LY	GV2ME32	LC1D32	100 A	LRD35
	15	ATS01N244LY	GV3ME63	LC1D50	125 A	LRD3357
15		ATS01N272LY	GV3ME63	LC1D50	150 A	LRD3357
	20	ATS01N272LY	GV3ME63	LC1D65	175 A	LRD3359
20		ATS01N272LY	GV3ME63	LC1D65	200 A	LRD3359
	25	ATS01N272LY	GV7RE80	LC1D80	200 A	LRD3363
	30	ATS01N285LY	GV7RE80	LC1D80	250 A	LRD3363

Motor hp		ATS01 Soft Start	GV Manual Starter	Isolation Contactor	Fast Acting Class J Fuses (1)	Overload Relay (2)
460/480 V	575/600 V					
20		ATS01N230LY	GV2ME32	LC1D32	90 A	LRD32
	30	ATS01N230LY	GV2ME32	LC1D32	100 A	LRD35
25		ATS01N244LY	GV3ME40	LC1D40	110 A	LRD3355
30		ATS01N244LY	GV3ME40	LC1D40	125 A	LRD3355
	40	ATS01N244LY	GV3ME63	LC1D50	125 A	LRD3357
40		ATS01N272LY	GV3ME63	LC1D50	175 A	LRD3359
	50	ATS01N272LY	GV3ME63	LC1D65	175 A	LRD3359
	60	ATS01N272LY	GV3ME63	LC1D80	200 A	LRD3359
50		ATS01N272LY	GV7RE80	LC1D65	200 A	LRD3361
60		ATS01N285LY	GV7RE80	LC1D80	250 A	LRD3363
	75	ATS01N285LY	GV7RE80	LC1D115	250 A	LRD3363 (3)

(1) Fuses are not required when using the GV manual starter with motor branch-circuit protection installed per NEC article 430.

(2) The overload relay is not required when using the GV manual starter.

(3) Requires separate mounting kit, part number LA7D3064.

ATS01N2●●LY soft start with GV manual starter, fusible disconnect, or other motor starter

Manual control without soft stop

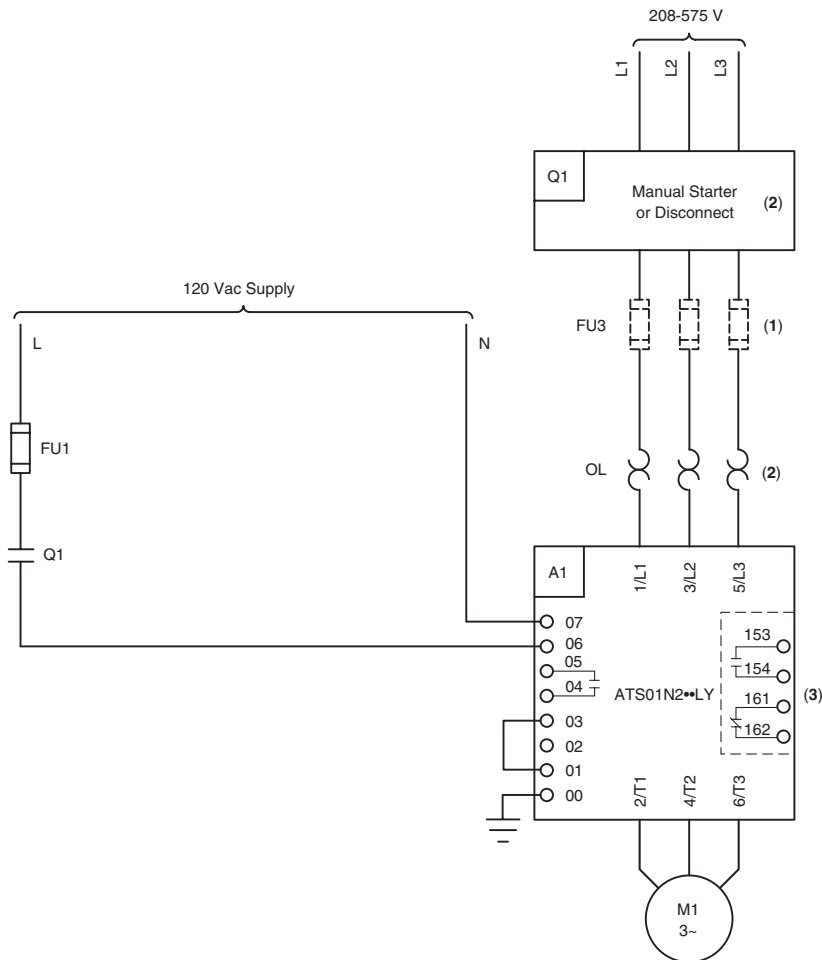

Timing Diagram

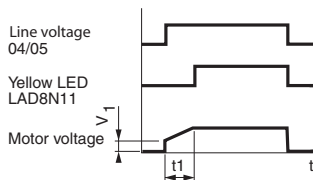

Notes:

- A1:** ATS01 soft start
- FU1:** Control circuit fuse
- FU3:** Fast-acting UL Listed Class J fuse
- Q1:** Manual motor starter or disconnect switch
- t1:** 1–25 second adjustable starting time
- V1:** Initial motor voltage – adjustable from 30 to 80% of the motor's rated voltage
- (1)** Fuses FU3 are not required if device Q1 is a GV manual motor starter installed per local and national electrical codes.
- (2)** Overload protection required if not included in device Q1.
- (3)** LAD8N11 optional up to speed relay output.

High Power Mini Soft Starts Wiring Diagrams

ATS01N2●●LY soft start with GV manual starter, fusible disconnect, or other motor starter

Hand-Off-Auto control with soft stop and isolation contactor

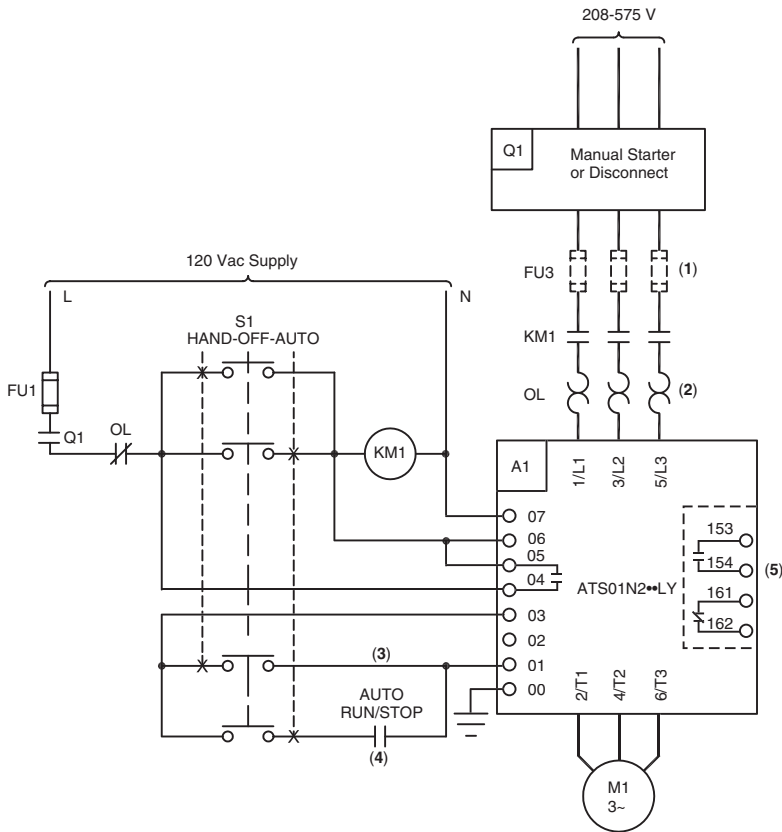

Timing Diagram

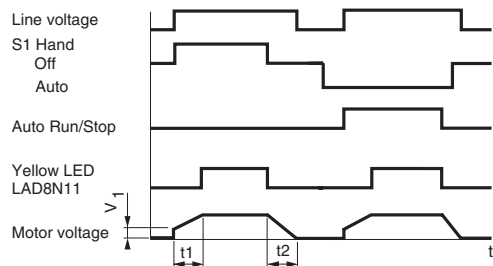

Notes:

- A1:** ATS01 soft start
- FU1:** Control circuit fuse
- FU3:** Fast-acting UL Listed Class J fuse
- KM1:** Isolation contactor
- OL:** Overload relay
- Q1:** Manual motor starter or disconnect switch
- S1:** Selector switch
- t1:** 1–25 second adjustable starting time
- t2:** 1–25 second adjustable stopping time
- V1:** Initial motor voltage – adjustable from 30 to 80% of the motor's rated voltage
- (1)** Fuses FU3 are not required if device Q1 is a GV manual motor starter installed per local and national electrical codes.
- (2)** Overload protection required if not included in device Q1.
- (3)** Use shielded cable if control wiring is longer than 3 feet.
- (4)** From automated control system.
- (5)** LAD8N11 optional up to speed relay output.

ATS01N2●●LY soft start with GV manual starter, fusible disconnect, or other motor starter

Hand-Off-Auto control with soft stop and without isolation contactor

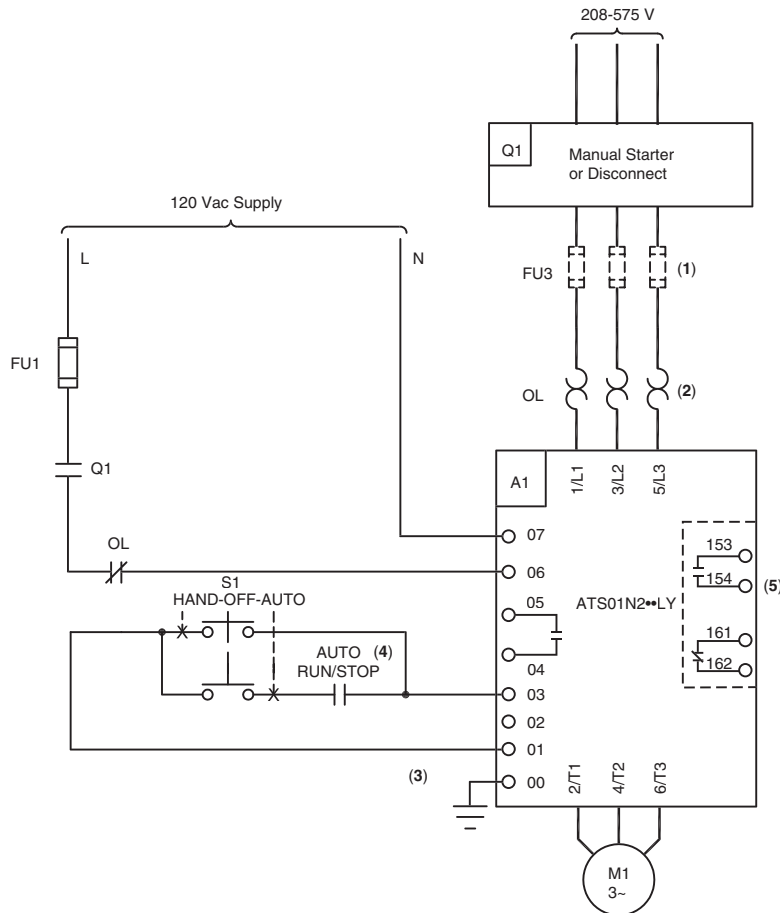

Timing Diagram

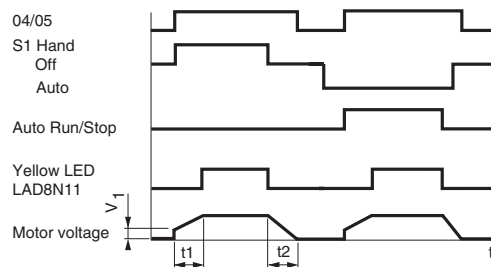

Notes:

- A1:** ATS01 soft start
- FU1:** Control circuit fuse
- FU3:** Fast-acting UL Listed Class J fuse
- KM1:** Isolation contactor
- OL:** Overload relay
- Q1:** Manual motor starter or disconnect switch
- S1:** Selector switch
- t1:** 1–25 second adjustable starting time
- t2:** 1–25 second adjustable stopping time
- V1:** Initial motor voltage – adjustable from 30 to 80% of the motor's rated voltage
- (1)** Fuses FU3 are not required if device Q1 is a GV manual motor starter installed per local and national electrical codes.
- (2)** Overload protection required if not included in device Q1.
- (3)** Use shielded cable if control wiring is longer than 3 feet.
- (4)** From automated control system.
- (5)** LAD8N11 optional up to speed relay output.

High Power Mini Soft Starts Wiring Diagrams

ATS01N2●●LY soft start with GV manual starter, fusible disconnect, or other motor starter

Automatic control (2 or 3-wire) with or without soft stop

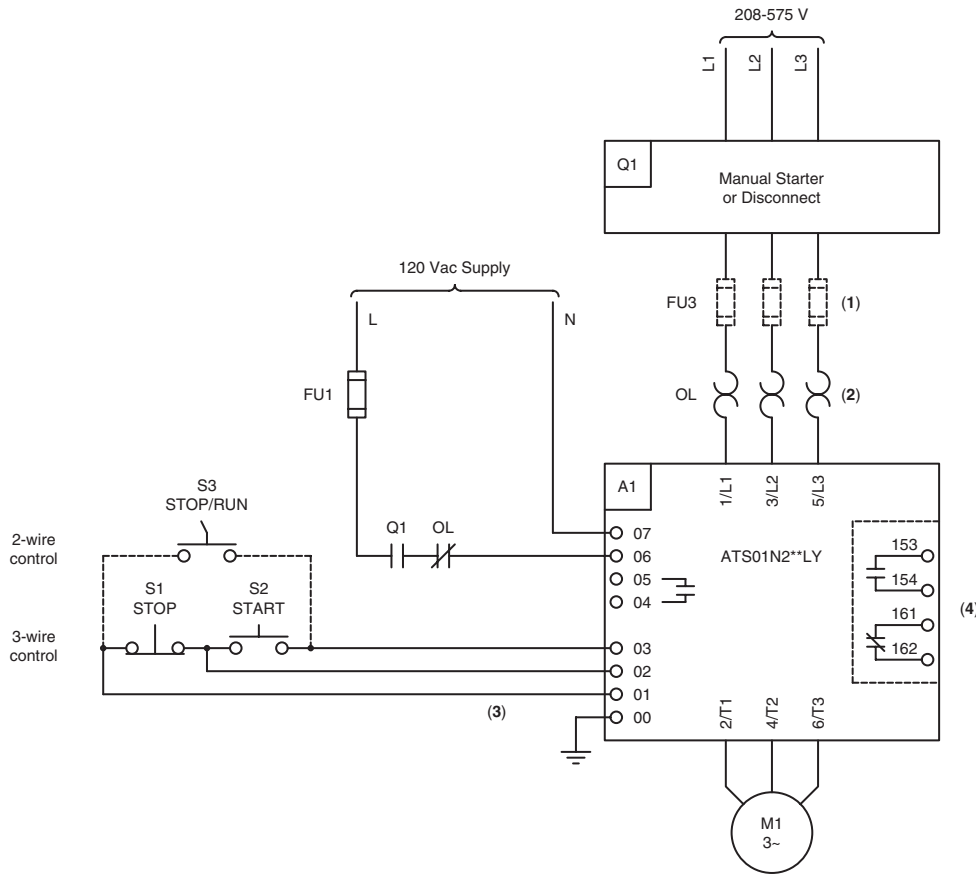

Timing Diagram

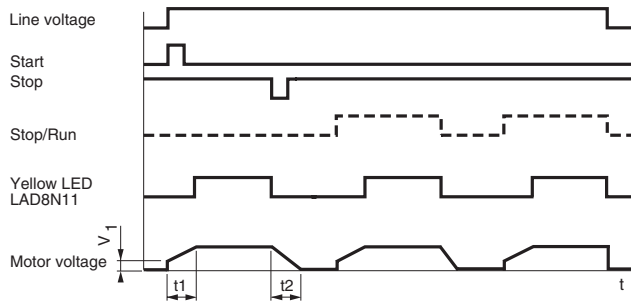

Notes:

- A1:** ATS01 soft start
- FU1:** Control circuit fuse
- FU3:** Fast-acting UL Listed Class J fuse
- OL:** Overload relay
- Q1:** Manual motor starter or disconnect switch
- S1, S2:** Momentary pushbuttons
- S3:** Selector switch
- t1:** 1–25 second adjustable starting time
- t2:** 1–25 second adjustable stopping time
- V1:** Initial motor voltage – adjustable from 30 to 80% of the motor's rated voltage
- (1) Fuses FU3 are not required if device Q1 is a GV manual motor starter installed per local and national electrical codes.
- (2) Overload protection required if not included in device Q1.
- (3) Use shielded cable if control wiring is longer than 3 feet.
- (4) LAD8N11 optional up to speed relay output.

ATS01N2●●LY soft start with GV manual starter, fusible disconnect, or other motor starter

Automatic 3-wire control with isolation contactor without soft stop

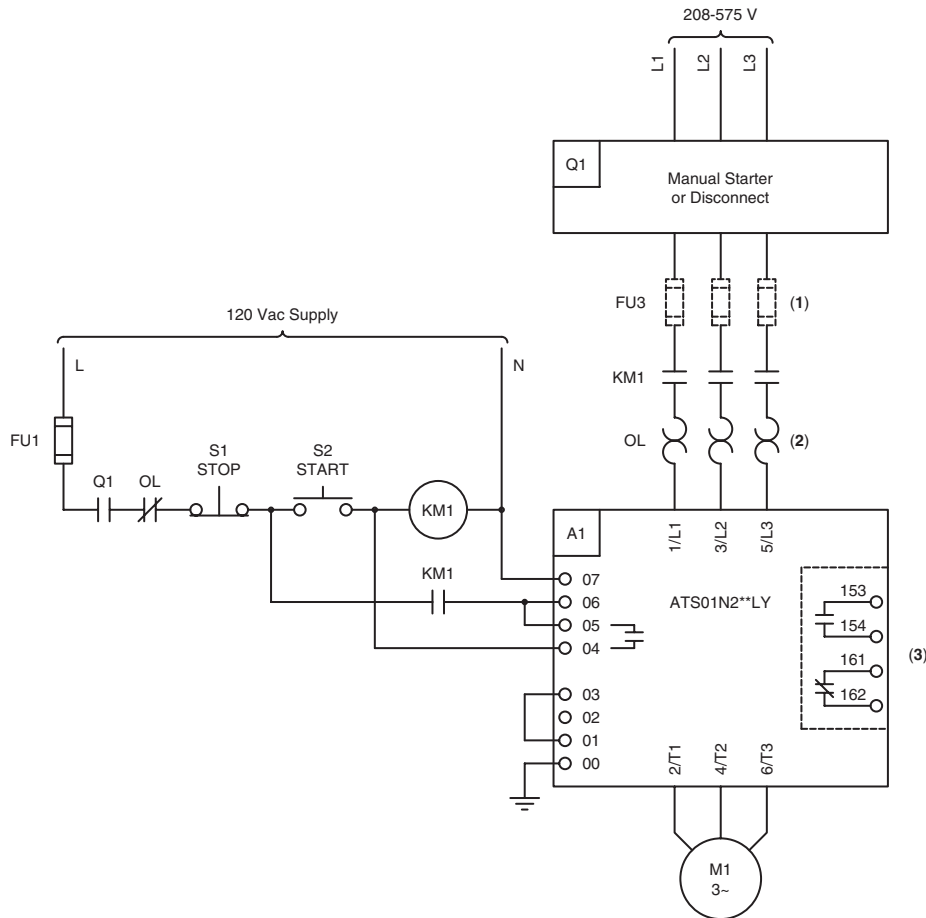

Timing Diagram

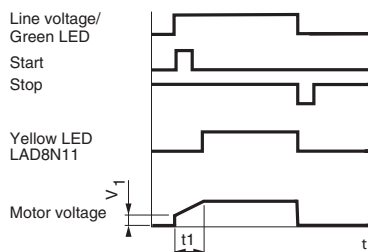

Notes:

- A1:** ATS01 soft start
- FU1:** Control circuit fuse
- FU3:** Fast-acting UL Listed Class J fuse
- KM1:** Isolation contactor
- OL:** Overload relay
- Q1:** Manual motor starter or disconnect switch
- S1, S2:** Momentary pushbuttons
- t1:** 1–25 second adjustable starting time
- V1:** Initial motor voltage – adjustable from 30 to 80% of the motor's rated voltage
- (1) Fuses FU3 are not required if device Q1 is a GV manual motor starter installed per local and national electrical codes.
- (2) Overload protection required if not included in device Q1.
- (3) LAD8N11 optional up to speed relay output.

ATS01N2**LY soft start with GV manual starter, fusible disconnect, or other motor starter

Automatic 3-wire control with reversing with or without soft stop

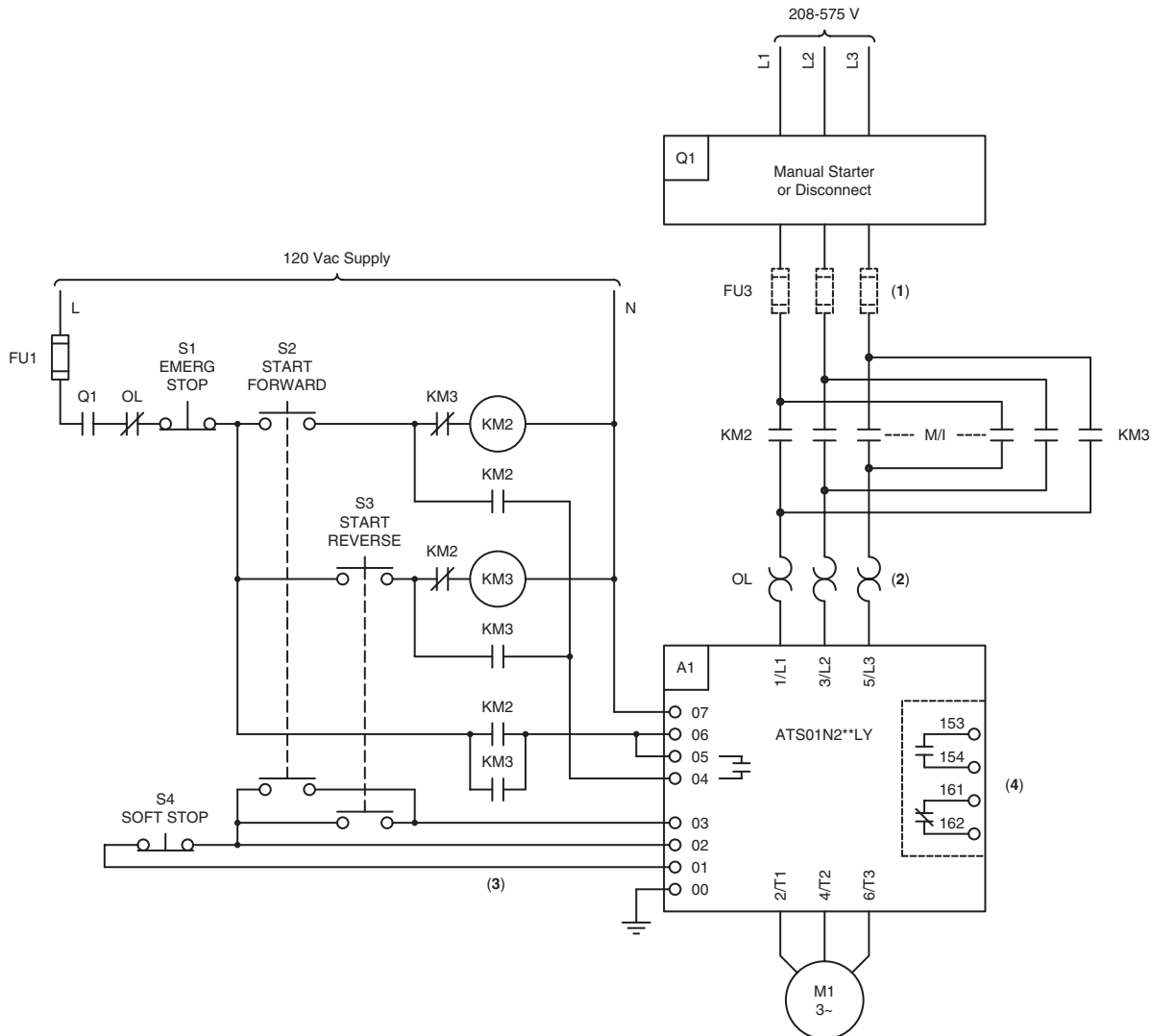

Timing Diagram

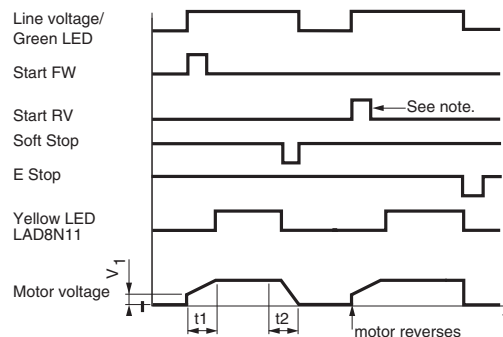

Note: To prevent possible internal ATS01 damage, wait for the motor to stop before changing motor direction.

Notes:

- A1:** ATS01 soft start
 - FU1:** Control circuit fuse
 - FU3:** Fast-acting UL Listed Class J fuse
 - KM2, KM3:** Reversing contactor
 - OL:** Overload relay
 - Q1:** Manual motor starter or disconnect switch
 - S1, S2, S3, S4:** Momentary pushbuttons
 - t1:** 1–25 second adjustable starting time
 - t2:** 1–25 second adjustable stopping time
 - V1:** Initial motor voltage – adjustable from 30 to 80% of the motor's rated voltage
- (1) Fuses FU3 are not required if device Q1 is a GV manual motor starter installed per local and national electrical codes.
 - (2) Overload protection required if not included in device Q1.
 - (3) Use shielded cable if control wiring is longer than 3 feet.

Overview:
pages 33–35

Characteristics:
pages 36–38

Dimensions:
page 39

Selection:
page 40

High Power Mini Soft Starts

Torque Limiting Mini Soft Starts Overview

Overview

ATS01N1 torque limiting mini soft starts extend the Altistart® 01 (ATS01) product range down into the fractional horsepower arena (3 to 12 A, 1/2 to 3 hp at 208 V). They can control the starting ramp of either a single-phase or a 3-phase motor.

As with other ATS01 models, the torque limiting soft starts make it possible to gradually and smoothly start a motor in a controlled manner. They are ideal for applications that do not require high starting torque. This transitionless starting method eliminates torque surges common with wye-delta starting methods. Using the ATS01 soft start avoids the damage and expense possible with an across-the-line start.

The ATS01N1 is ideal for the following applications:

- small conveyors for fragile goods, such as bottle conveyors
- constant power machines, such as drills, where the starting torque must be limited

By reducing the starting torque produced by an asynchronous motor, the ATS01N1 soft start extends the motor's starting time. The ATS01N1 soft start ramps up the AC voltage applied to one of the motor terminals. The other motor terminal(s) are supplied full motor starting voltage. Hence, starting current is not reduced.

This range of the ATS01 family is compatible with the following common motor voltages:

- single phase: 115 V and 230 V
- three phase: 208 V, 230 V, and 460 V

The ATS01N1 soft start is compatible with most single-phase motor designs, including split phase induction, capacitor start, and shaded pole.

The Altistart 01 was designed to meet IEC 60947-4-2, the internationally accepted standard defining soft starts, and carries the following agency approvals: UL, CSA, CCC, C-Tick, and CE.

The ATS01N1 series is one of the smallest soft starts on the market. It comes in two frame sizes:

- 22.5 mm wide modules, rated for 3 and 6 A
- 45 mm wide modules, rated for 9 and 12 A

Both can be DIN rail or panel mounted. They can be mounted side-by-side with no gap between soft starts required.

An internal shorting contactor is provided on the 9 A and 12 A ATS01N1 models to eliminate wasted energy and reduce the heat that must be removed from the control panel.

The 9 A and 12 A models offer removable control terminal plugs for ease of wiring and installation.

Description

The ATS01 torque limiting soft start is equipped with:

- a potentiometer to set the starting time (3)
- a potentiometer to set the initial voltage applied to the motor when starting begins (4)
- 1 green LED to indicate that soft start power is on (1)
- 1 yellow LED that illuminates 10 seconds after a start command is given indicating that the soft start's voltage ramp is complete, the internal shorting contactor (9 and 12 A models only) is closed, and the motor is up to speed (2)
- a control terminal with inputs for either 24 Vac/dc or 110–240 Vac control power input (5)
- the control terminal is removable on 9 and 12 A models



3 and 6 A model



9 and 12 A model

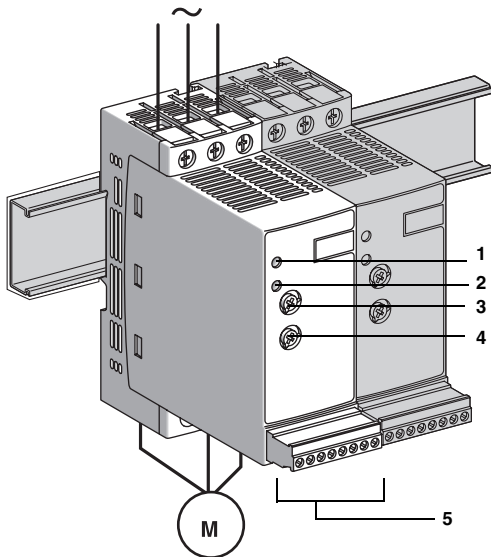
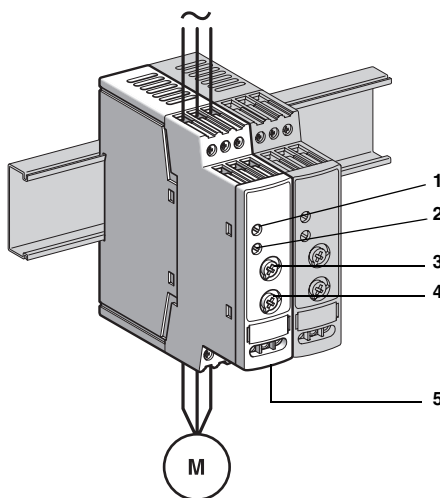

Torque Limiting Mini Soft Starts Functions

Altistart® 01 soft start functions

- Starting and stopping the ATS01N1 soft start:
The motor starts when both line and control power are supplied to the soft start.
The soft start will not soft stop the motor. When the run command is removed, the motor will coast to a stop.
If only line power is removed to stop the motor, reapplying line power will not restart the motor. Soft start control power must also be cycled off and on to restart the motor. In a single-phase application, the soft start will allow the motor to stop when either line or control power is removed.

Note: In a 3-phase application, connect line power to the soft start *ONLY* when soft start control power is present and motor operation is needed. Applying line power when no soft start control power is present will single phase the connected 3-phase motor.

- Control power
Control power can be either:
 - 110 to 220 Vac (+/- 10%): terminals CL1/0 and CL2
 - 24 Vac/dc (+/- 10%): terminals CL1/0 (-) and 24 V (+)
- Line power
Line power must match the voltage rating of the motor and must not exceed 480 V.
 - Single-phase motors
Power in: ATS01N1 terminals 1/L1 and 5/L3
Power out: ATS01N1 terminals 2/T1 and 6/T3
 - Three-phase motors
Power in: ATS01N1 terminals 1/L1, 3/L2, and 5/L3
Power out: ATS01N1 terminals 2/T1, 4/T2, and 6/T3
- Starting times
The ATS01N1 soft start controls the starting time of the motor by ramping up the voltage applied to one phase of the motor. The starting voltage ramp time can be adjusted from 1 to 5 seconds by means of the potentiometer on the front of the soft start. Since the actual motor starting time is dependent on the level of the applied load, the scale on the front of the soft start is calibrated from A to E rather than from 1 to 5 seconds, with A being the shortest time and E being the longest time.
The starting voltage ramp begins at the AC line voltage level set by the Initial Voltage adjustment. See the diagram below for more detail.

Note: The ATS01 soft start is internally bypassed at the end of the time set by the start time adjustment. If the motor is not up to speed by that time (due to a heavy load), the internal contactor can be damaged, requiring replacement of the soft start.
SET THE START TIME AT A LEVEL ACHIEVABLE WITH THE MOTOR AT ITS HIGHEST LOAD LEVEL.

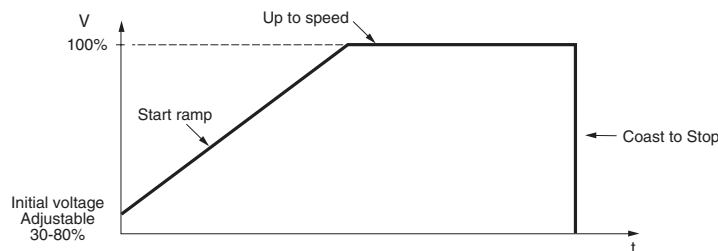

Voltage start ramp, initial voltage, and up to speed

- Initial (or starting) voltage
The initial voltage applied to the motor (the level at which the voltage ramp begins) can be adjusted by a potentiometer on the front of the ATS01N1 soft start. The initial voltage level can be adjusted from approximately 30 to 80% of the AC line voltage level. See the diagram above.
Since the resultant motor torque varies in proportion to the square of the applied voltage (see the diagram on page 6), the scale on the front of the soft start is calibrated from A to E rather than from 30 to 80%, with A being the lowest level and E being the highest level.
A lower setting will reduce motor torque during starting.
Set this level to the minimum required that will result in motor rotation immediately after a start command.

Torque Limiting Mini Soft Starts Characteristics

Environment

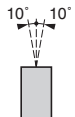
Type of starter	ATS01N1●●FT	
Conformity to standards	Altistart® 01 soft starts conform to the strictest international standards and recommendations relating to electrical industrial control devices, in particular the standard IEC 60947-4-2.	
Electromagnetic compatibility EMC		
Conducted and radiated emissions	CISPR 11 level B, IEC 60947-4-2, level B	
Harmonics	IEC 61000-3-2, IEC 61000-3-4	
EMC immunity	EN 50082-2, EN 50082-1	
Electrostatic discharge	IEC 61000-4-2 level 3	
Immunity to radiated radio-frequency electromagnetic field	IEC 61000-4-3 level 3	
Immunity to electrical transients	IEC 61000-4-4 level 4	
Surge immunity	IEC 61000-4-5 level 3	
Immunity to conducted radio-frequency electromagnetic field	IEC 61000-4-11	
Immunity to voltage disturbances	IEC 61000-4-6 level 3	
Damped oscillating waves	IEC 61000-4-12 level 3	
CE marking	The soft starts are CE marked on the basis of European directives governing low voltage (72/73/EEC) and EMC (89/336/EEC).	
Product certification	UL, CSA, CCC and C-Tick.	
Degree of protection	IP20	
Degree of pollution	2 (conforming to IEC 60947-4-2)	
Vibration resistance	1.5 mm peak to peak from 3 to 13 Hz, 1 gn from 13 to 150 Hz conforming to IEC 60068-2-6	
Shock resistance	15 gn for 11 ms conforming to IEC 60068-2-27	
Relative humidity	5–95% without condensation or dripping water, conforming to IEC 60068-2-3	
Ambient temperature around the unit	Storage	- 25 to + 70 °C (-13 to +158 °F) conforming to IEC 60947-4-2
	Operation	- 10 to + 40 °C (+14 to +104 °F) without derating, up to 50 °C (122 °F) with current derating of 2% per °C above 40 °C (1.1% per °F above 104 °F)
Maximum operating altitude	1000 m (3300 ft) without derating Above this, derate the current by 2.2% per additional 100 m (330ft).	
Side-by-side mounting	No gap between soft starts is required	
Operating position Maximum permanent angle in relation to a vertical mounting position		

Overview:
pages 49–50

Dimensions:
page 54

Selection:
page 55

Wiring Diagrams:
pages 56–57

Torque Limiting Mini Soft Starts Characteristics

Electrical characteristics

Type of starter		ATS01N1●●FT			
Category of use	Conforming to IEC 60947-4-2	AC-53b			
Rated AC supply voltage	single-phase three-phase	110–240 Vac 200–480 Vac			
AC line voltage tolerance		-15% to +10%			
Frequency		50 or 60 Hz ± 5%			
Output voltage		Maximum output voltage equal to AC supply voltage.			
Control supply voltage		110–220 Vac or 24 Vac/dc (± 10%)			
Rated operating current		3, 6, 9, and 12 A			
Adjustable starting time		1–5 s			
Starting voltage		30–80% of motor's rated voltage			
Type of starter	ATS01N1	03FT	06FT	09FT	12FT
Control power supply consumption		110 Vac, 30 mA 24 Vac/dc, 25 mA 240 Vac, 65 mA		110 Vac, 35 mA 24 Vac/dc, 30 mA 240 Vac, 80 mA	
Power dissipated	At full load at end of starting	4 W	1 W	1 W	1 W
	During starting and stopping at 5 times the rated operating current	19 W	31 W	46 W	61 W
Type of starter		ATS01N1●●FT			
	Starting time at 5 times the rated operating current	1 s		5 s	
	Max. number of cycles per hour	310		20	

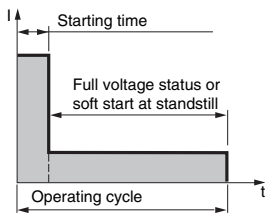

ATS01 Control Terminals

CL1/0	CL2	24 V
-------	-----	------

Control Terminal Description	110–230 Vac	24 Vac/dc
CL1/0 and CL2 or CL1/0 and 24 V Control power (electrical isolation between line power and control power)	Connect line supply to CL2 Connect neutral to CL1/0	Connect (+) to 24 V Connect (-) to CL1/0
LED signalling		
Green LED	Soft start power on	
Yellow LED	Voltage ramp complete, motor up to speed	



Torque Limiting Mini Soft Starts Characteristics

Connections (Maximum connection capacity and tightening torque)

Type of Soft Start	ATS01N1	03FT/06FT		09FT/112FT	
Power circuit		Cage type connector		Connection onto Ø 4 mm screw terminals	
Stranded wire without cable end	1 conductor	2.5 mm ²	(14 AWG)	1.5–10 mm ²	(16–8 AWG)
	2 conductors	1 mm ²	(18 AWG)	1.5–6 mm ²	(16–10 AWG)
Stranded wire with cable end	1 conductor	2.5 mm ²	(14 AWG)	1–6 mm ²	(18–10 AWG)
	2 conductors	0.75 mm ²	(18 AWG)	1–6 mm ²	(18–10 AWG)
Solid wire	1 conductor	2.5 mm ²	(14 AWG)	1–10 mm ²	(18–8 AWG)
	2 conductors	1 mm ²	(18 AWG)	1–6 mm ²	(18–10 AWG)
Tightening torque		0.8 N•m	(7 in-lb)	1.9–2.5 N•m	(16.9–22.1 in-lb)
Control circuit		Cage type connector		Screw connector	
Stranded wire without cable end	1 conductor	2.5 mm ²	(14 AWG)	0.5–2.5 mm ²	(20–14 AWG)
	2 conductors	1 mm ²	(18 AWG)	0.5–1.5 mm ²	(20–16 AWG)
Stranded wire with cable end	1 conductor	2.5 mm ²	(14 AWG)	0.5–1.5 mm ²	(20–16 AWG)
	2 conductors	0.75 mm ²	(18 AWG)	0.5–1.5 mm ²	(20–16 AWG)
Solid wire	1 conductor	2.5 mm ²	(14 AWG)	0.5–2.5 mm ²	(20–14 AWG)
	2 conductors	1 mm ²	(18 AWG)	0.5–1 mm ²	(20–18 AWG)
Tightening torque		0.8 N•m	(7 in-lb)	0.5 N•m	(4.43 in-lb)

Torque Limiting Mini Soft Starts Dimensions

ATS01N103FT, ATS01N106FT

Mounting on  (35 mm) DIN rail or
 rail with adaptor RHZ 66

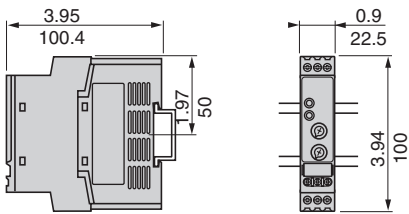

ATS01N109FT, ATS01N112FT

Mounting on  (35 mm) DIN rail

Panel Mounting

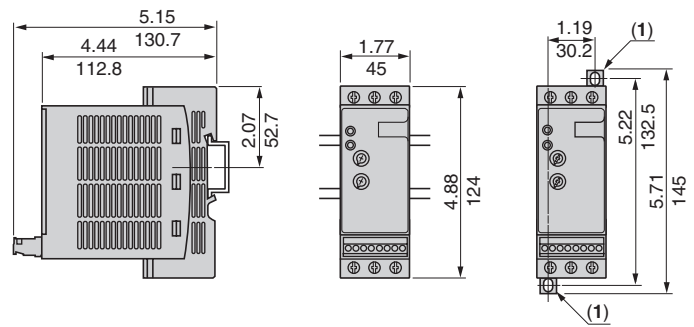

(1) Retractable screw tabs

Dimensions: $\frac{\text{in.}}{\text{mm}}$

Torque Limiting Mini Soft Starts Selection

1-Phase Motor		ATS01 Soft Start	GV Manual Starter	Isolation Contactor with AC Coil	Isolation Contactor with DC Coil	Fast Acting Class J Fuses (1)	Overload Relay (2)
hp							
115/120 V	230/240 V						
	1/4	ATS01N103FT	GV2ME08	LC1D09 or LC1K06	LC1D09 or LP1K06	10 A	LRD08 or LR2K0310
	1/3	ATS01N106FT	GV2ME08	LC1D09 or LC1K06	LC1D09 or LP1K06	15 A	LRD08 or LR2K0310
	1/2	ATS01N106FT	GV2ME10	LC1D09 or LC1K06	LC1D09 or LP1K06	15 A	LRD10 or LR2K0312
1/4		ATS01N106FT	GV2ME10	LC1D09 or LC1K06	LC1D09 or LP1K06	20 A	LRD12 or LR2K0314
1/3	3/4-1	ATS01N109FT	GV2ME14	LC1D09 or LC1K09	LC1D09 or LP1K09	25 A	LRD12 or LR2K0314
1/2	1.5	ATS01N112FT	GV2ME16	LC1D12 or LC1K12	LC1D12 or LP1K12	30 A	LRD16 or LR2K0316
	2	ATS01N112FT	GV2ME16	LC1D12	LC1D12	35 A	LRD16

3-Phase Motor				ATS01 Soft Start	GV Manual Starter	Isolation Contactor with AC Coil	Isolation Contactor with DC Coil	Fast Acting Class J Fuses (1)	Overload Relay (2)
hp			kW						
200/208 V	230/240 V	460/480 V	400 V						
			0.37	ATS01N103FT	GV2ME05	LC1D09 or LC1K06	LC1D09 or LP1K06	3 A	LRD05 or LR2K0306
		1/2		ATS01N103FT	GV2ME06	LC1D09 or LC1K06	LC1D09 or LP1K06	3 A	LRD06 or LR2K0306
		3/4	0.55	ATS01N103FT	GV2ME06	LC1D09 or LC1K06	LC1D09 or LP1K06	6 A	LRD06 or LR2K0307
		1	0.75	ATS01N103FT	GV2ME07	LC1D09 or LC1K06	LC1D09 or LP1K06	6 A	LRD07 or LR2K0308
1/2	1/2		1.1	ATS01N103FT	GV2ME07	LC1D09 or LC1K06	LC1D09 or LP1K06	10 A	LRD07 or LR2K0308
		1.5		ATS01N103FT	GV2ME08	LC1D09 or LC1K06	LC1D09 or LP1K06	10 A	LRD08 or LR2K0310
	3/4	2		ATS01N106FT	GV2ME08	LC1D09 or LC1K06	LC1D09 or LP1K06	10 A	LRD08 or LR2K0310
3/4			1.5	ATS01N106FT	GV2ME08	LC1D09 or LC1K06	LC1D09 or LP1K06	15 A	LRD08 or LR2K0310
1	1	3	2.2	ATS01N106FT	GV2ME10	LC1D09 or LC1K06	LC1D09 or LP1K06	15 A	LRD10 or LR2K0312
	1.5			ATS01N106FT	GV2ME10	LC1D09 or LC1K06	LC1D09 or LP1K06	20 A	LRD12 or LR2K0314
	2		3	ATS01N109FT	GV2ME14	LC1D09 or LC1K09	LC1D09 or LP1K09	20 A	LRD12 or LR2K0314
1.5-2		5		ATS01N109FT	GV2ME14	LC1D09 or LC1K09	LC1D09 or LP1K09	25 A	LRD12 or LR2K0314
			4	ATS01N109FT	GV2ME14	LC1D09 or LC1K09	LC1D09 or LP1K09	25 A	LRD14 or LR2K0316
	3			ATS01N112FT	GV2ME16	LC1D12 or LC1K12	LC1D12 or LP1K12	30 A	LRD16 or LR2K0316
3		7.5	5.5	ATS01N112FT	GV2ME16	LC1D12 or LC1K12	LC1D12 or LP1K12	35 A	LRD16 or LR2K0316

(1) Fuses are not required when using the GV manual starter with motor branch-circuit protection installed per NEC article 430.

(2) Overload relay is not required when using the GV manual starter.

Torque Limiting Mini Soft Starts Wiring Diagrams

ATS01N1●●FT soft start with GV manual starter, fusible disconnect, or other motor starter

Automatic 3-wire control with isolation contactor (three-phase motor)

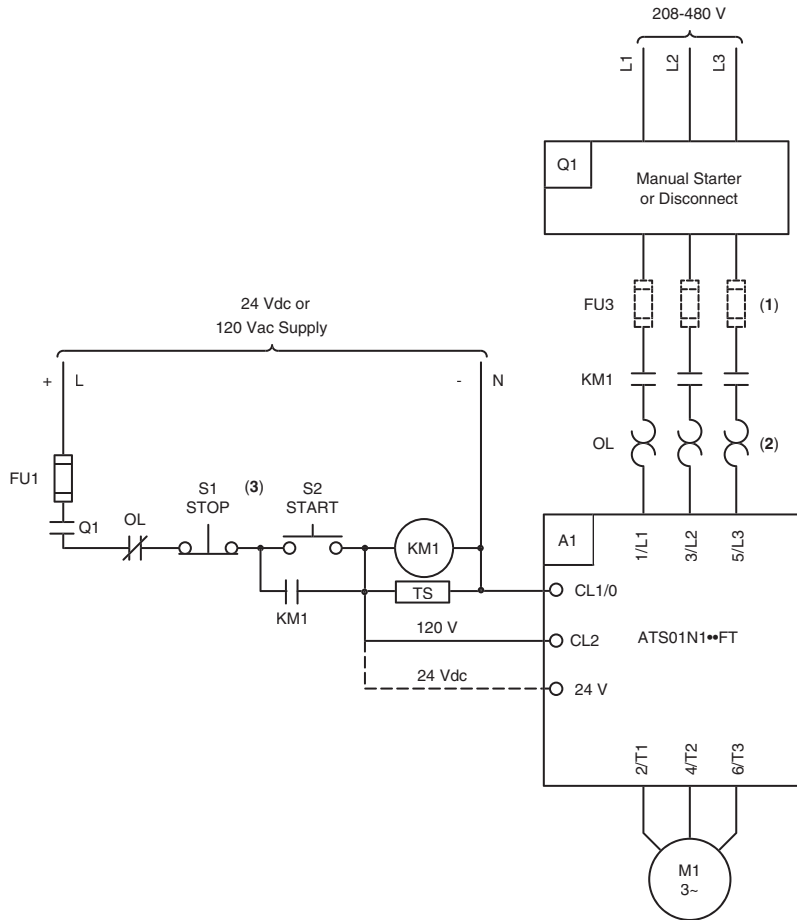

Timing Diagram

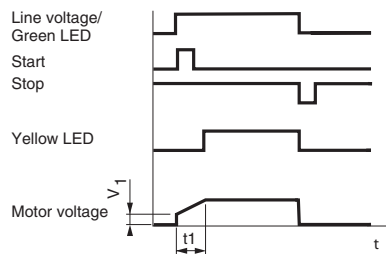

Notes:

- A1:** ATS01 soft start
- FU1:** Control circuit fuse – 120 Vac control power only
- FU3:** Fast-acting UL Listed Class J fuse
- KM1:** Isolation contactor
- TS:** Transient suppressor
- OL:** Overload relay
- Q1:** Manual motor starter or disconnect switch
- S1, S2:** Momentary pushbuttons
- t1:** 1–5 second adjustable starting time
- V1:** Initial motor voltage – adjustable from 30 to 80% of the motor's rated voltage
- (1) Fuses FU3 are not required if device Q1 is a TeSys® U-Line or GV manual motor starter installed per local and national electrical codes.
- (2) Overload protection required if not included in device Q1.
- (3) Wait 5 seconds after switching off the soft start before switching it on again.

ATS01N1●●FT soft start with GV manual starter, fusible disconnect, or other motor starter

Automatic 3-wire control with isolation contactor (single-phase motor)

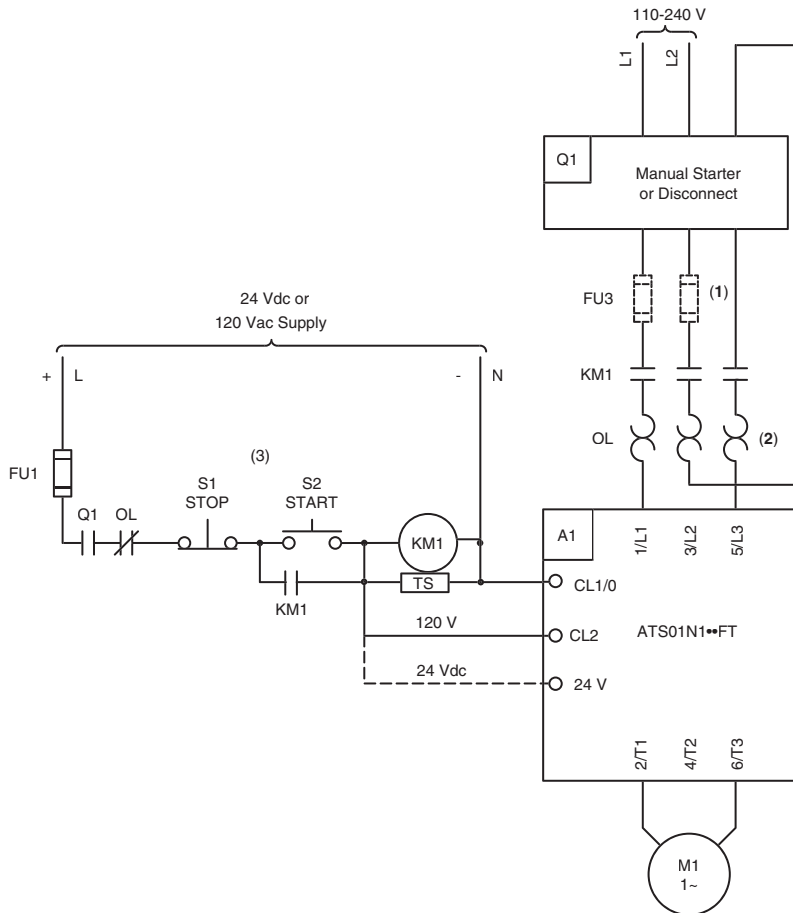

Timing Diagram

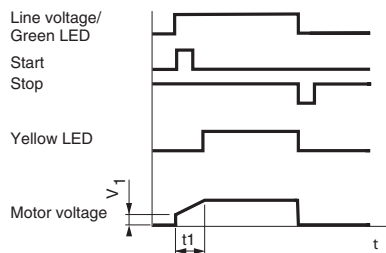

Notes:

- A1:** ATS01 soft start
- FU1:** Control circuit fuse – 120 Vac control power only
- FU3:** Fast-acting UL Listed Class J fuse
- KM1:** Isolation contactor
- TS:** Transient suppressor
- OL:** Overload relay
- Q1:** Manual motor starter or disconnect switch
- S1, S2:** Momentary pushbuttons
- t1:** 1–5 second adjustable starting time
- V1:** Initial motor voltage – adjustable from 30 to 80% of the motor's rated voltage
- (1)** Fuses FU3 are not required if device Q1 is a TeSys® U-Line or GV manual starter. motor starter installed per local and national electrical codes. Fuse is not required on neutral leg.
- (2)** Overload protection is required if not included in device Q1.
- (3)** Wait 5 seconds after switching off the soft start before switching it on again.

Torque Limiting Mini Soft Starts

Altistart® 01
Soft Starts

Schneider Electric USA
8001 Highway 64 East
Knightdale, NC 27545
1-888-SquareD
(1-888-778-2733)
www.us.SquareD.com

Schneider Electric Canada
19 Waterman Avenue,
M4B 1 Y2
Toronto, Ontario
1-800-565-6699
www.schneider-electric.ca

Catalog No. 8637CT0401 August 2004 © 2004 Schneider Electric All Rights Reserved