

# VF61

**INTELLIGENT INVERTER**

## INSTRUCTION MANUAL



820 Lakeside Drive - Gurnee, IL. 60031  
1-(800) DRIVCON (374-8266)  
PH: (847) 855-9150 FAX: (847) 855-9650  
<http://www.drivecon.com> Email: [sales@drivecon.com](mailto:sales@drivecon.com)

12-17-96 REV.

## **Introduction**

Thank you for your purchase of Drivecon Corporation's VF61 series inverter.

Please read through this instruction manual carefully prior to using it and get familiar with proper installation, wiring and operations to ensure optimum and trouble-free operation.

This instruction manual describes the basic and standard operation procedures. See the catalog for the specifications, capacity, outer dimensions, environmental conditions and so forth.

The VF61 series is to be used for a custom designed product or system, use the values written in the drawings or test report of them, not the values shown in this manual.

## **Precautions for Safe Operation**

1. Supply the specified voltage to the input terminals of the inverter. (If 400V power supplied to the 200V type inverter, the inverter will be broken.)
2. Provide the input side of the inverter with an MCB of the proper capacity.
3. Be sure to connect the inverter to the ground to prevent accidents.
4. Do not connect the supply line to the output of the inverter. Otherwise, the inverter will be broken.
5. Do not connect a phase advancing capacitor to the output terminals of the inverter. Otherwise, the inverter will be broken.
6. Before maintenance work or inspection, turn the inverter power off to avoid electric shock. Wait until the "CHG" LED goes out. Note that the heatsink may be hot in some operating conditions.
7. Do not change the parts or make reckless alterations.
8. The inverter has no noise suppression device. Please contact us if such a device is necessary.

## **Memory protection**

We recommend that set data be protected against rewriting in order to prevent misuse of the console.  
(See 2.5)

## Table of Contents

1.	Before starting operation	
1.1	Checking supplied components and parts	1
1.2	Structure of unit	1
1.3	Installation	2
1.4	Circuit construction and terminal wiring	3
1.5	Peripheral devices and wire sizes	5
2.	How to use console	
2.1	Display the keys on console	6
2.2	Monitor mode	6
2.3	Function mode	7
2.4	Operation mode	9
2.5	How to protect data	9
3.	Automatic measuring	
3.1	Inputting motor data	10
3.2	Automatic measuring operations	10
4.	Operation procedures	
4.1	Connecting inverter to motor	11
4.2	Inputting basic data	11
4.3	Operation from console	11
5.	Troubleshooting	
5.1	Error messages and operations	12
5.2	Troubleshooting	13
5.3	Phase failure of input power source	14
6.	Inspection and maintenance	
6.1	Periodical inspection	15
6.2	Insulation resistance test	15
6.3	Precautions for replacing printed circuit board	16
6.4	Disposal	16
7.	Appendix	
7.1	Enclosure dimensions	17
7.2	Typical wiring diagram	18
7.3	Operator unit dimensions	19
7.4	Standard specifications	20
7.5	VF61 Programming chart	21
7.6	D61532 (D61533) Input Signal Isolator Board instructions	26

1. Before starting operation

1.1 Checking supplied components and parts.

When you receive the VF61, check it carefully.

(1) Make sure that the specifications of VF61, accessories and spare parts are properly in accordance with your order. Check the logo mark on the cover to see if the unit type is as you ordered.

Example: 2R2: 2.2

3R7: 3.7

5R5: 5.5

7R5: 7.5

200V type: 22

400V type: 44

Voltage (V)

Inverter capacity (kW)

Applicable power source INPUT: 380 to 460V, 3-phase, 50/60 Hz

OUTPUT: 2.2kW, 5.5A

(2) Make sure that the supplied VF61 hasn't been damaged during transportation.

(3) Make sure that no screws, bolts, etc. are loose or dislocated.

If you find some problems, contact the dealer you purchased the VF61 from.

1.2 Structure of the unit

1.2.1 Appearance of unit and components

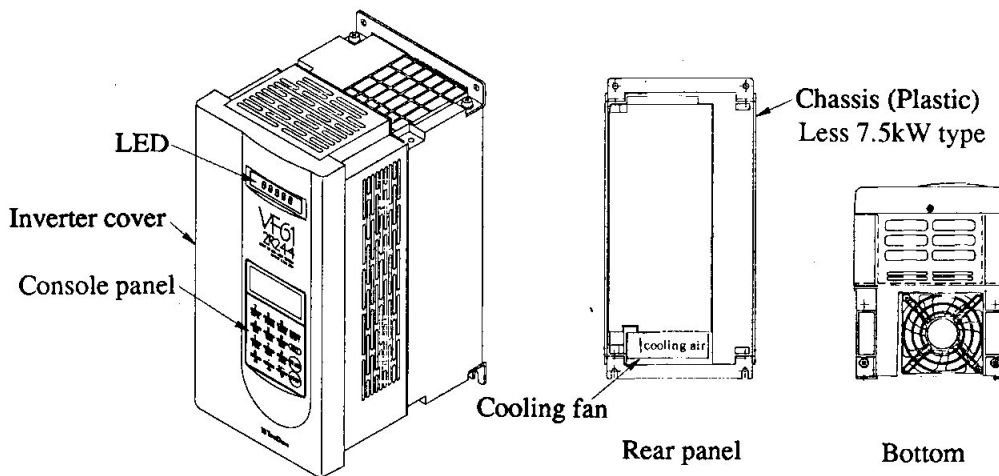

### 1.2.2 Opening of front cover

If you are going to inspect the VF61 or carry out automatic measuring (described in section 3 below), open the front cover as shown below.

- (1) Remove the fixing screws from the bottom of the front cover.
- (2) Draw the front cover to the front.
- (3) When the front cover is fully opened, push it. The cover is fixed in the Up position.

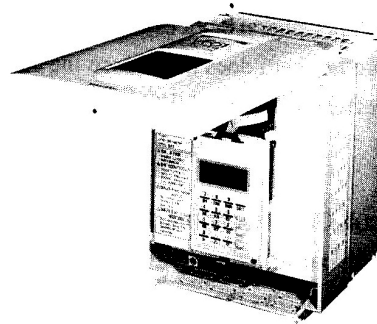

### 1.3 Installation

1.3.1 The installation condition has great influences upon the service life and reliability of the inverter. Do not use the inverter in the places shown below. Be sure to run the inverter in the operating conditions shown in the catalog.

op-

- (1) A moist or dusty place. A place exposed to water or oil drips.  
If the inverter is used in such a place, the circuit insulation is deteriorated, resulting in shorter service life of the parts.
- (2) Extreme heat or cold out of the specified temperature range.  
If the service temperature is too high, bad influences are caused upon capacitors, and parts of cooling fan or motor, etc.
- (3) A place exposed to corrosive gas  
Corrosive gas deteriorates the reliability of the parts and/or connecting part.
- (4) A place with much vibrations.  
Vibrations cause poor contact of the connectors, disconnection of wires, damage to parts, etc.

### 1.3.2 Installation direction

If the VF61 is used separately or built into a control panel, follow the instructions below.

- (1) Installation direction  
Install the VF61 vertically with its marking "VF61" upward as shown below.

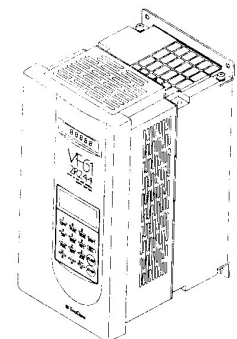

- (2) Securing cooling spaces  
 Provide the VF61 with proper cooling spaces as shown on the right. The cooling fan takes air from the bottom and exhausts it to the top. Secure enough spaces so that a wire duct, etc. do not hinder proper ventilation.  
 Install peripheral devices so that heat generated by them does not reduce the cooling efficiency of the VF61.

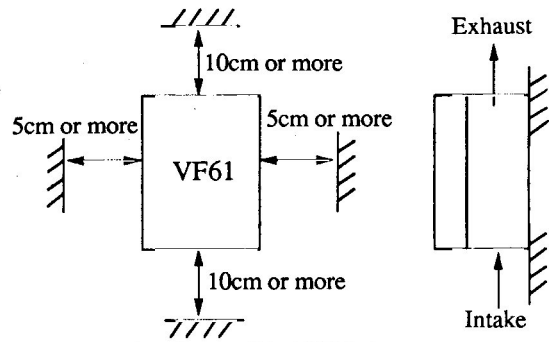

The ambient temperature of the VF61 should be 50°C or less.

Note: The inverter capacity of over 11kW needs to take up space two times.

## 1.4 Circuit construction and writing terminal

### 1.4.1 Circuit construction

The following shows the standard circuit construction of the VF61.

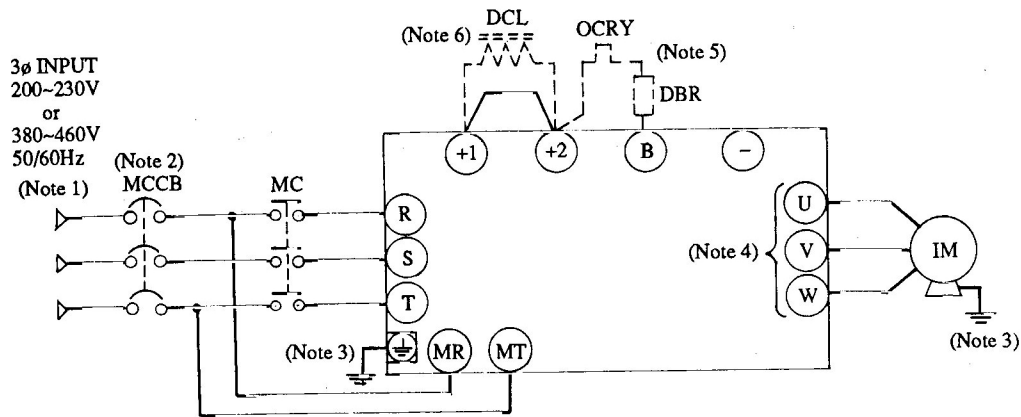

### Safety Precautions

1. Supply the specified voltage to the inverter. If 400V power is applied to the 200V type inverter, damage will occur. (Note 1)
2. Be sure to provide the inverter with an MCB of the proper capacity. See 1.5 below. (Note 2)
3. Be sure to connect the inverter and motor to the ground to prevent accidents. (Note 3)
4. Connect a motor to the inverter output terminals. Do not connect the supply line to them. Otherwise, the inverter will be damaged. (Note 4)

### Options

1. Connect a dynamic brake resistor. (Note 5)
2. Connect a DC reactor DCL. (Note 6)

## 1.4.2 Terminal blocks

### (1) Main circuit terminal block

- R, S and T      Connect AC power to these terminals. (Do not supply 400V to the 200V type inverter.)
- Terminal 1 and 2      Connect the wires of the optional DC reactor DCL to these terminals. These terminals are short circuited before shipment.
- Terminal 2 and B      Connect the optional dynamic braking (DB) resistor to these terminals.
- Terminal 2 and 0      Connect the optional DB unit and resistor to these terminals.

### (2) Control terminal block

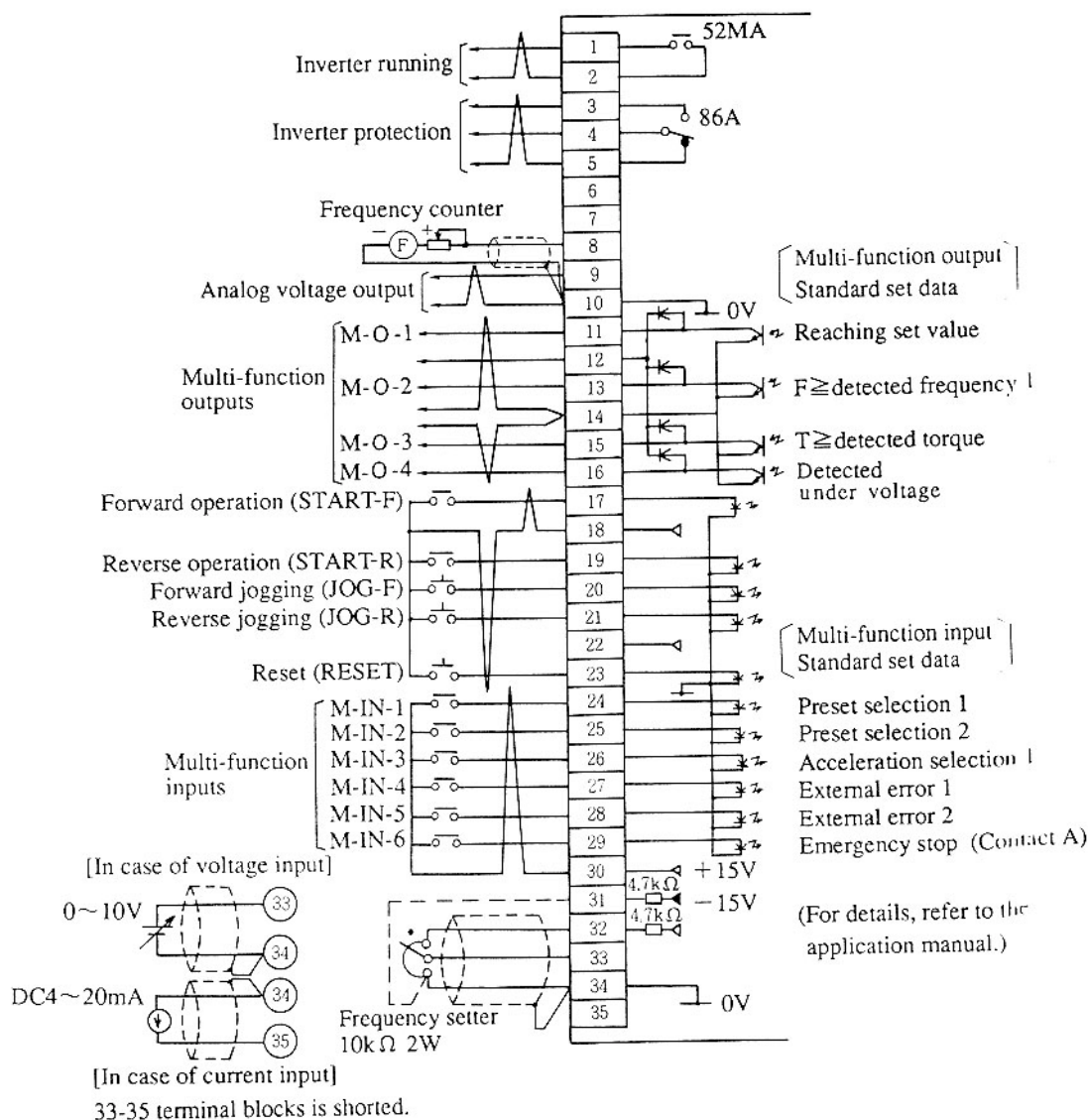

## Safety Precaution

Terminals 10 and 34 carry 0V of the control circuit. Never connect these terminals to GND.

## 1.5 Peripheral devices and wire sizes

### 1.5.1 Selection of I/O devices and precautions for main circuit wiring.

The following shows the I/O devices of the VF61 unit and their wire sizes.

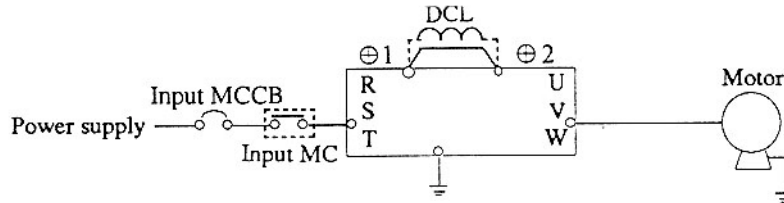

#### 200V type

Type		VF61-___22												
		2R222	3R722	5R522	7R522	1122	1522	2222	3022	3722	4522	5522	7522	9022
Applicable motor (HP)		3	5	7.5	10	15	20	30	40	50	60	75	100	130
Peripheral device	Input MCCB (Note 1)	15A	20A	30A	40A	60A	60A	100A	125A	150A	225A	300A	400A	400A
	Input MC (Note 2)	K20	K20	K35	K50	K65	K65	K95	K125	K150	K220	K300	K400	K400
	Output MC	K20	K20	K25	K35	K50	K65	K95	K125	K150	K220	K300	K300	K400
Wire size (mm <sup>2</sup> )	Input side (Note 3)	2.0	2.0	3.5	5.5	8.0	8.0	22	38	38	60	80	150	150
	Output side (Note 4)	3.5	5.5	8.0	14	14	22	22	38	38	60	80	100	150
	DCL terminals (1 & 2)	2.0	2.0	3.5	5.5	8.0	14	38	38	50	80	100	150	200

#### 400V type

Type		VF61-___44															
		2R244	3R744	5R544	7R544	1144	1544	2244	3044	3744	4544	5544	7544	11044	16044	20044	25044
Applicable motor (HP)		3	5	7.5	10	15	20	30	40	50	60	75	100	150	200	250	300
Peripheral device	Input MCCB (Note 1)	15A	10A	15A	30A	50A	50A	75A	75A	100A	100A	125A	200A	300A	400A	500A	600A
	Input MC (Note 2)	K20	K20	K20	K25	K35	K50	K50	K80	K95	K100	K125	K180	K300	K400	K600	K600
	Output MC	K20	K20	K20	K20	K25	K50	K50	K80	K95	K95	K125	K150	K220	K300	K400	K600
Wire size (mm <sup>2</sup> )	Input side (Note 3)	2.0	2.0	2.0	2.0	3.5	5.5	8.0	14	14	22	38	60	80	150	200	250
	Output side (Note 4)	2.0	2.0	2.0	3.5	5.5	8.0	8.0	14	22	38	38	80	150	150	150	250
	DCL terminals (1 & 2)	2.0	2.0	2.0	3.5	5.5	8.0	14	22	38	38	60	100	200	250	250	150(x2)

#### Notes:

- The values of the input MCB show the rated currents.  
(Determine the breaking capacity from the source capacity, etc.)
- The shown values are those of the electromagnetic contactors MS-K series made by Mitsubishi Electric Corp.
- The wire sizes between the MCB and inverter input terminals are the sizes of the KIV or RD wires.
- The cable length between the inverter and motor should be less than 30 meters. The shown values are those of the CV cables.
- If the input MC is used, the interval between turning on and off should be more than 10 minutes.

#### Safety Precautions

- If the motor has a phase advancing capacitor, be sure to disconnect it. (If the inverter runs with the phase advancing capacitor connected, the inverter may be broken.)
- Be sure to connect a circuit breaker (input MCB) on the inverter input side.
- Be sure to connect the inverter and motor to ground.  
(Use the exclusive grounding terminal.)

## 2. How to use console

### 2.1 Display and Keys on Console

The console has 16 columns x 4 lines LCD and operation keys as shown below.

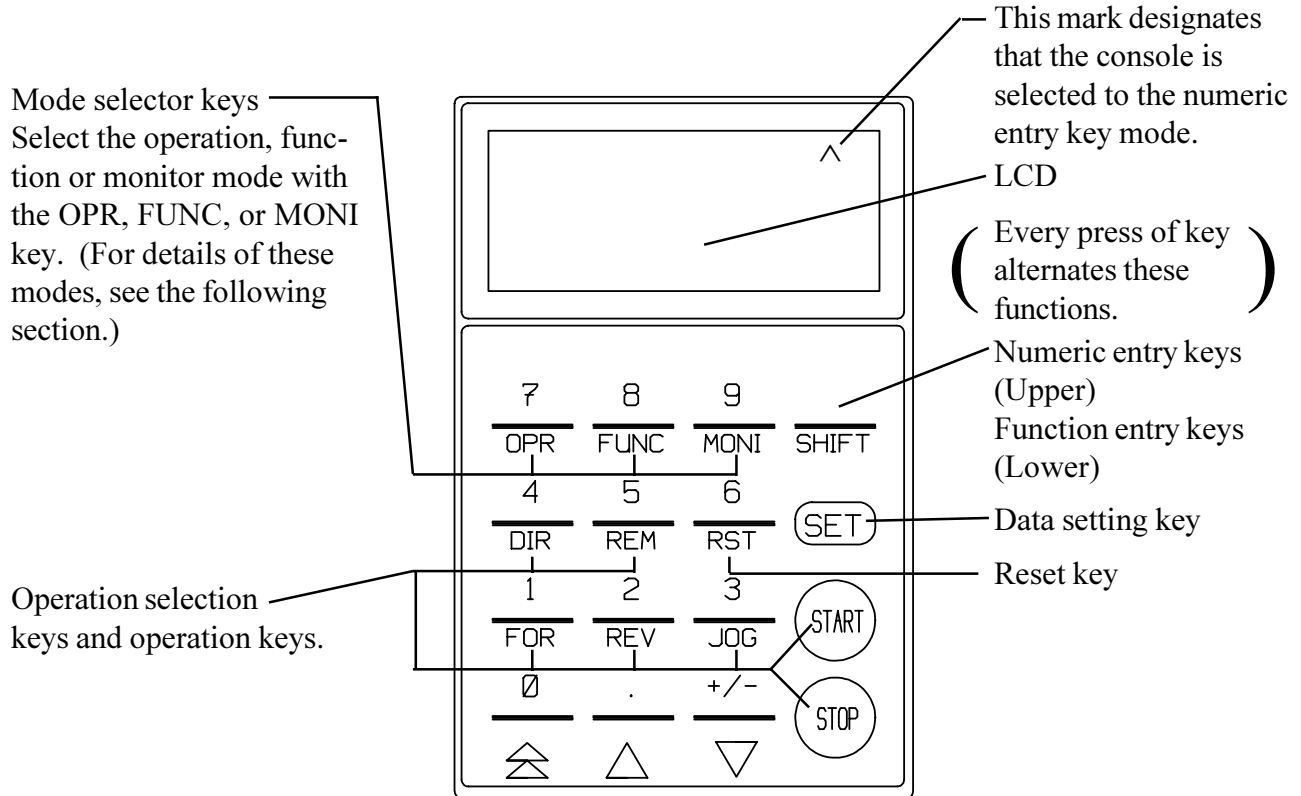

### 2.2 Monitor mode

Press the MONI key, and the current setting is displayed as shown below.

- 2.2.1 A monitor code (of 16 codes) and operation condition are displayed.  
(See 2.2.2 for displayed items)

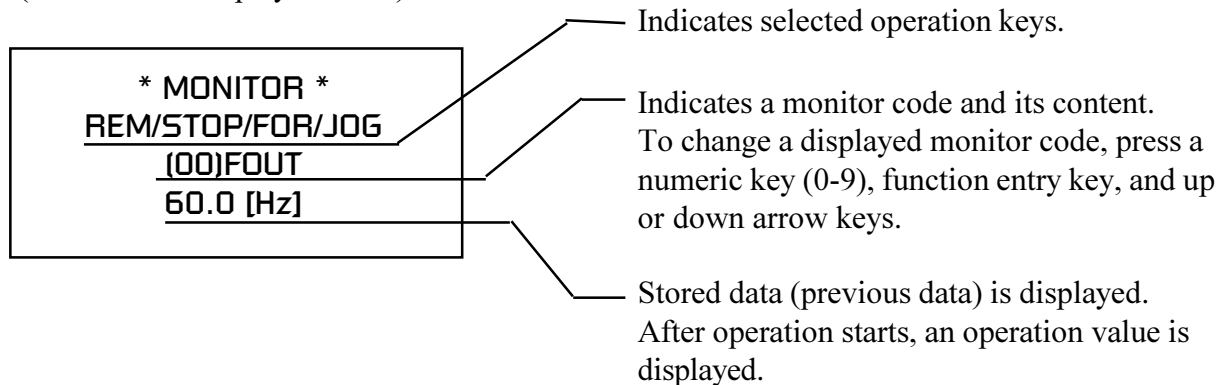

### 2.2.2 Displayed code list (Items selectable in monitor mode)

	Display on LCD	Items	Units	Remarks
00	Fout	Output frequency	Hz	
01	Fref	Set frequency	Hz	
02	Iout	Output current	A	
03	Vout	Output voltage	V	
04	Torq out	Torque (Torque current)	%	Estimated torque is displayed in percentage
05	Vdc	DC voltage	V	
06	Motor speed	Motor (synchronous) revolution	rpm	Actual revolution is displayed in ASR operation. Revolution converted from frequency is displayed in other operations.
07	OL counter	OL counter	%	OL counter begins to count when current exceeds rated motor current. OL operation starts at 100%. (OL set=100%)
08	Line speed	Line speed	...	

	Display on LCD	Items	Units	Remarks
09	I1term check	Input terminal check 1	bit	1 is displayed when terminal block is turned on. For meaning of each bit, see table below.
10	I2term check	Input terminal check 2	bit	Ditto
11	O-term check	Output terminal	bit	Ditto
12				
13				
14				
15	ROM Version	ROM Version		"XX-XX" of ROM software version VF61-XX-XX is displayed through conversion of alphabetic characters into numeric characters like A=0, B=1 and so forth.
16	Special moni	For manufacturer's adjustment		
17	Trouble moni	Reading error records.		Contents of latest five errors and current, voltage, etc. of these errors are displayed.

Code 09 I1term check	Code 10 I2term check	Code 11 O-term check

## 2.3 Function mode

Press the FUNC key, and current data is displayed as shown below.

### 2.3.1 The internal data of the setting functions may be checked and changed. (See 2.3.3 below.)

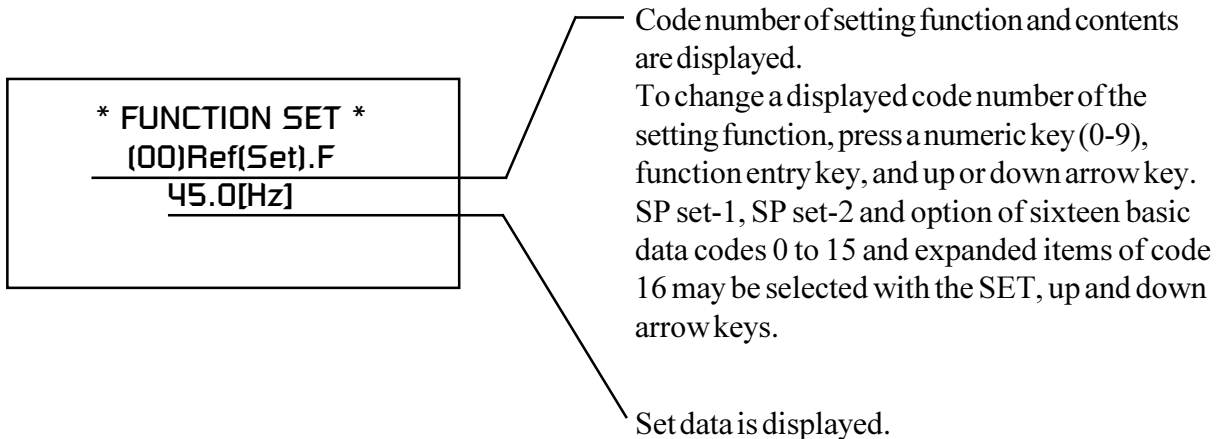

### 2.3.2 Changing set data

#### (1) Before changing data

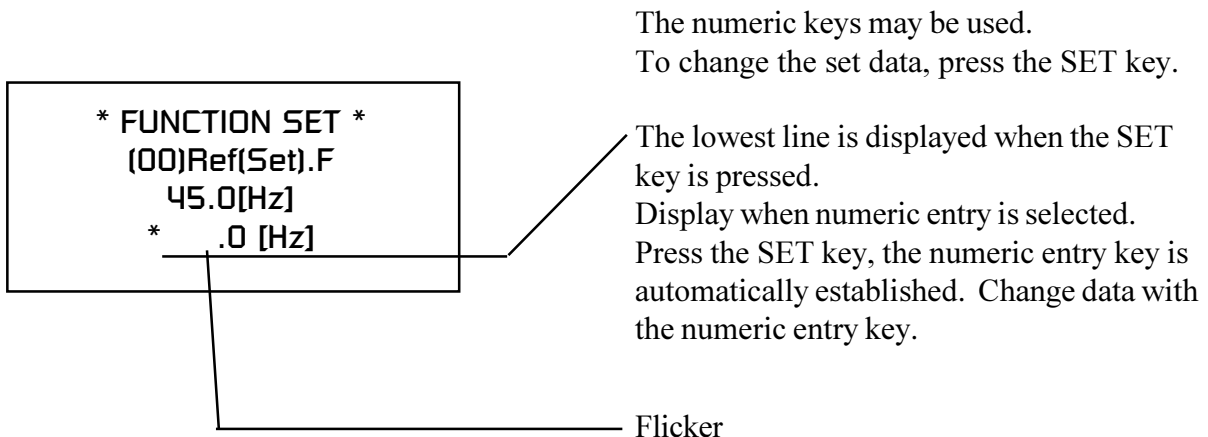

(2) After changing data

Change data, then press the SET key.

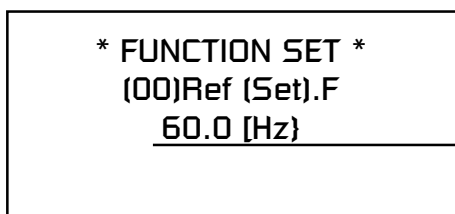

The lowest display disappears, and new data appears.

2.3.3 Set data code list (Items selectable in function mode)

Code Numbe	Display on LCD	Descriptions	Set ranges (Selection items)	Standard factory set data	Setting resolution	Units	Rewriting in operation	Remarks
00	Ref(Set).F	Set frequency	-Top.F Top.F	0.0	0.1	Hz	O	
01	FOR-JOG.F	Forward jogging frequency	0.0 30.0	5.0	0.1	Hz	O	
02	REV-JOG.F	Reverse jogging frequency	0.0 30.0	5.0	0.1	Hz	O	
03	Preset1.F	Preset frequency 1	-Top.F Top.F	0.0	0.1	Hz	O	
04	Preset2.F	Preset frequency 2	-Top.F Top.F	0.0	0.1	Hz	O	
05	Top.F	Max. frequency	Fmax 400.0 (Note 1)	60.0	0.1	Hz	X	Fmax means the maximum of Ref(Set).F, PC-Base.F and other set values whose upper limit is Top.F
06	PC-Base.F	Power control (base) frequency	30.0 Top.F	60.0	0.1	Hz	X	
07	Rated Out.V	Rated output voltage	280-500 140-250	400 200	1 1	V V	O O	Depends on the 400V and 200V classes
08	Accl.Time	Acceleration time (1)	0.1 3600.0	30.0	0.1	sec	X	
09	Decl.Time	Deceleration time (2)	0.1 3600.0	30.0	0.1	sec	X	
10	Torq.Boost	Torque boost volume	0.0-20.0	0.0	0.1	%	O	
11	Min F	Min.frequency	0.0-10.0	0.5	0.1	Hz	O	
12	OL.Set	Setting overload ratio	80-110	100	1	%	O	
13	V/F Pattern	V/F pattern selection	Linear Sqr-Law Bend	Linear			X	Linear: V/F linear Sqr-Law: V/F square reduction Bend: V/F folded line
14	Start.Mode	Start mode selection	Min.F start Free start	Min.F start			X	Min.F start: Starting at minimum frequency Free start: Free starting
15	Stop.Mode	Stop mode selection	Decel stop Free stop	Decel stop			X	Decel stop: Stopping after deceleration Free stop: Free stopping
16	Function.up	Expanded set item selection	Sp.set-1 Sp.set-2 Option	Sp.set-1			O	For selecting items 17 and after. See the application manual.

Note 1: When changing the set data of code number 05 "Top.F (maximum frequency)", also change the over-frequency in the following procedures:  
 Select code number 16 "Expanded set item selection" to select.  
 Sp.set-1. Display code number 21 OF.Set. Change data to a value higher than the setting of code 05 Top.F with the SET and numeric key entry.

2.3.4 Data recording

- (1) When data of each function has been set, it should be protected as shown in 2.5 below.
- (2) We recommend that function data be stored separately, before maintenance work, in order to prevent the data from being lost due to unexpected accidents.

## 2.4 Operation Mode

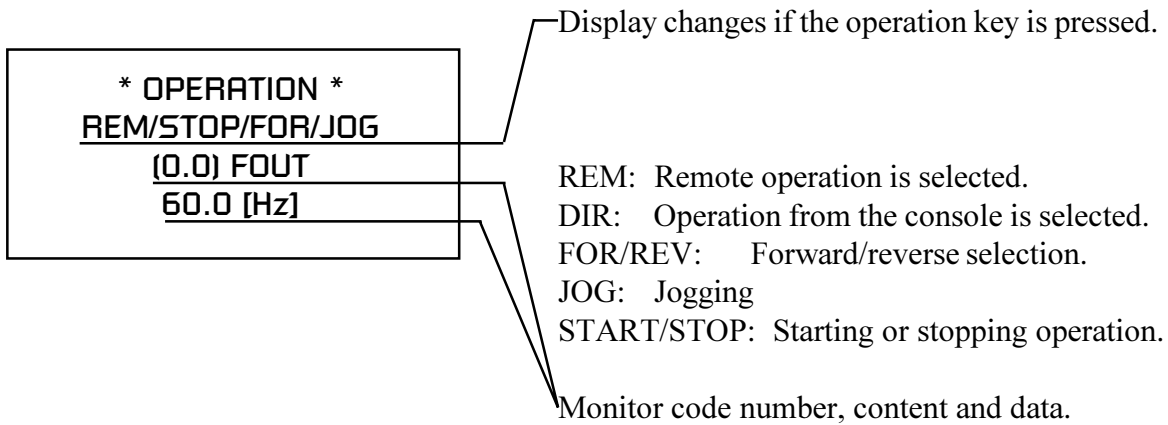

## 2.5 How to protect Data

On completion of adjustment, protect data in order to prevent it from being written or lost by maloperation, etc..

- (1) Remove the cover from the unit. Open the console to the right.

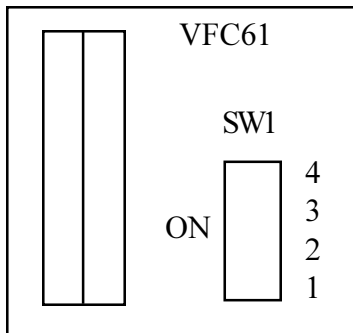

Set switch 4 of SW1 on the control PCB (VFC61) to ON.  
Any data cannot be written in the function mode.

- (2) Undo the console. Close the cover.

### **Safety precaution**

Be sure to protect data while the VFC61 is stopped.

## 3. Automatic Measuring

The exact constants (resistances) of the motor used with inverter should be set in order to run the inverter properly.

Carry out automatic measuring for the motor only by disconnecting the motor from the load.

### **Safety precaution**

As the voltage is impressed to the motor by automatic measuring, connect the GND terminal of the motor to ground.

### 3.1 Inputting Motor Data

- (1) Press the FUNC key.
- (2) Select code number 16. Press the SET key, select SP, set-2 with the up or down arrow keys, and press the SET key again.
- (3) Change the code number displayed on the console one by one with the up or down arrow key. Set the data shown on the right according to the rating indicated on the name plate of the motor.

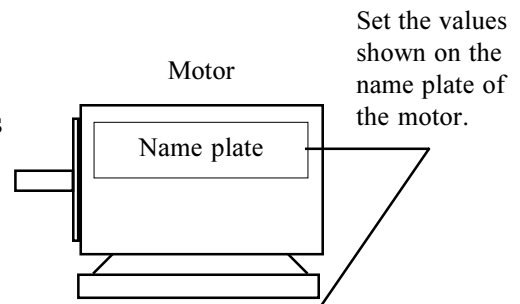

Code #	Functions	Set items	Data
17	Motor.Cap	Rated capacity	7.5kW
18	Motor.V	Rated voltage	200V
19	Motor.I	Rated current	30A
20	Motor.F	Rated frequency	60Hz
21	Motor.RPM	Rated revolution	1740 rpm
22	Motor.Pole	Number of poles	4 pole

(The above table shows the factory set values of the inverter model 7r522)

### 3.2 Automatic Measuring Operation

- (1) Open the cover. Open the console to the right.
- (2) Set switch 3 of SW1 on the control PCB (VFC61) to ON.

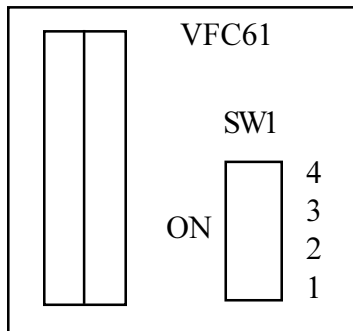

Note the following functions of switches 1 to 4 of SW1.

Pin #	Functions
1	Inputted data is cleared and reset to the standard data.
2	For manufacturer's adjustment. (Do not set this switch to ON)
3	Automatic measuring mode.
4	Data protection

**r1-ch** is displayed on the 7-segment LEDs on the VFC61.

- (3) Press the OPR key on the console to select the operation mode. Make sure that the DIR mode is established.
- (4) Press the START key. (Current flows to the motor) After approximately 20 seconds, **r1END** is displayed on the 7-segment LEDs in the upper part of the unit, indicating that automatic measurement is completed.

Open the console to the right again. Set switch 3 of SW1 on the control PCB (VFC61) to OFF. Data has been set now.

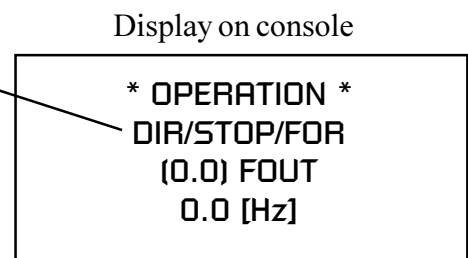

## 4. Operating Procedures

### 4.1 Connecting inverter to motor

If the inverter output terminal U, V and W are connected to the motor terminals U, V and W and the motor is operated in the forward direction, it rotates clockwise viewed from the position opposite to the transmission side.

### 4.2 Inputting Basic Data

The values indicated on the name plate of the motor have been set in automatic measuring described in 3.1 above. Set the values shown on the right according to the operation method. (Also set other items according to necessity)

- (1) Press the FUNC key.
- (2) Change code numbers displayed on the console with the up and down arrow keys, and set the items shown on the right one by one.
- (3) Select the set frequency (Fref) on the monitor. Press the MONI key, and code (00) Fout is selected. Increase the code number to (01) with the Up key to select (01) Fref.

#### Basic data setting

Code #	Functions	Set items (Ex.)
00	Ref(Set).F	25Hz
05	Top.F	60Hz*
06	PC-Base.F	60Hz
07	Rated out V	200V
13	V/F.Pattern	Liner
14	Start.Mode	Min.F start
15	Stop.Mode	Decel stop

\* Setting for 05 Top.F should be equal to or greater than those for 06 PC-Base.F.

### 4.3 Operation from Console

Press the OPR key to select the operation mode.

Press the DIR key. \_\_\_\_\_

- (1) Normal operation

Press the START key. Make sure that the motor rotates in the forward direction at the set frequency (25Hz). Then, press the STOP key. The motor is decelerated and then stops.

#### Display on console

**\* OPERATION \***  
**DIR/STOP/FOR**  
**(0.0) FOUT**  
**5.0 [Hz]**

- (2) Jogging

Press the JOG key. The motor rotates at the set frequency (5Hz) while the JOG key is being pressed. \_\_\_\_\_

Select the forward or reverse direction with the FOR or REV key.

**\* OPERATION \***  
**DIR/STOP/FOR/JOG**  
**(0.0) FOUT**  
**5.0 [Hz]**

#### 4.4 Operating through Terminal Block

Press the OPR key, then press the REM key.

- (1) Activate the forward operation signal (between terminals 17 and 18 shown on page 4)
- (2) Turn the frequency setter (F.set) shown on page 4 clockwise. The motor velocity is increased within the time set with code number 08 Acc.Time.  
(Connect the frequency setter properly)
- (3) Deactivate the forward operation signal. The motor is decelerated within the time set with code number 00 Dec.Time and then stops.
- (4) To run the motor reversely, activate the reverse operation signal (between terminals 19 and 18).

Display on console

```

* OPERATION *
DIR/STOP/FOR
(0.0) FOUT
25.0 [Hz]
```

## 5. Troubleshooting

### 5.1 Error Messages and Operations

When the inverter malfunctions or becomes out of order, an error message and an error code are displayed on the console and 5-digit, 7-segment LEDs. The inverter stops and error contacts 3, 4, and 5 go active when an error occurs. In such a case, see the table shown below, locate the error cause, and take proper countermeasures. Also refer to the contents and values of monitor code 17 Trouble moni (i.e., reading error records).

Display on console	Display on LEDs	Error contents	Protection	Error contacts	Retry	Causes and countermeasures
Overcurrent	oC	Excessive output current	Inverter Stops	Active		The inverter output current exceeds the allowable value. See 5.2.2
IGBT Fault	iGbt	IGBT error (7.5kW or less)	Inverter Stops	Active		The IGBT(IPM) is out of order. Error details: Overcurrent, abnormal gate power supply, or overheat. See 5.2.4
IGBT(U) Fault	iGt1	IGBT (U phase) error (11kW or less)	Inverter Stops	Active		
IGBT(V) Fault	iGt2	IGBT (v phase) error (11kW or less)	Inverter Stops	Active		
IGBT(W) Fault	iGt3	IGBT (W phase) error (11kW or less)	Inverter Stops	Active		
Over Voltage	oU	Excessive DC voltage	Inverter Stops	Active	O	
Over Load	oL	Overload (Electronic thermal)	Inverter Stops	Active		Overload current flows for long time. See 5.2.5
Blown DC fuse	FU	Main circuit fuse blown	Inverter Stops	Active		The IGBT is broken, and the fuse blows out. See 5.2.6
Start Failure	StrF	Malfunctioning in starting	Inverter Stops	Active		The inverter fails to start operation, though an operation signal is inputted. (Instantaneous stop occurs in the instantaneous stop mode)
Over Freq	oF	Over-frequency	Inverter Stops	Active		The output frequency exceeds the over-frequency.
EXT Failure-1	En1	External error 1	Inverter Stops	Active		An external error. Check the input.
EXT Failure-2	En2	External error 2		Active		An external error. Check the input.

Display on console	Display on LEDs	Error contents	Protection	Error contacts	Retry	Causes and countermeasures
EXT Failure-3	En3	External error 3	Inverter stops	Active		Check the external error input side.
EXT Failure-4	En4	External error 4	Inverter stops	Active		Check the external error input side.
Panel Error	PnEr	Console panel error	Inverter stops	Active		Check the connector of the console panel.
Option Error	OPEr	Internal optional board error	Inverter stops	Active		Check the optional printed circuit board.
EEPROM Error	c52	Data storage error	Inverter stops	Active		The default data is not stored, or the control board is out of order.
	c51	Program memory (ROM) error	Inverter stops	Active		
	uU	Under voltage (Power failure)		Inactive		

## 5.2 Troubleshooting

If trial running fails or an error occurs during operation, locate the cause in the procedures shown below. If there are no applicable items below, contact us or the dealer you purchased your VF61.

### Safety Precautions

1. Never open the cover while the power is being supplied to the inverter.
2. Before inspecting the inverter, turn the inverter power off, open the inverter cover, and make sure that the CHG LED on the printed board is off.
3. Note that the heat sink may be hot according to the use conditions.

#### 5.2.1 Motor does not run

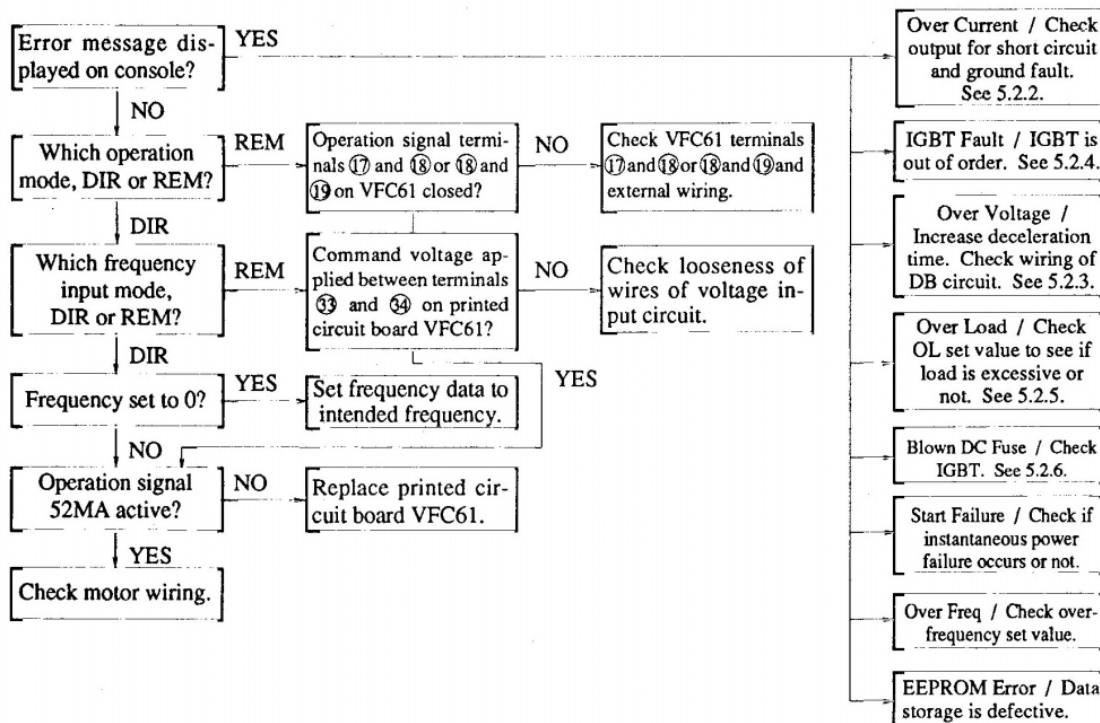

### 5.2.2 *oc* flashes

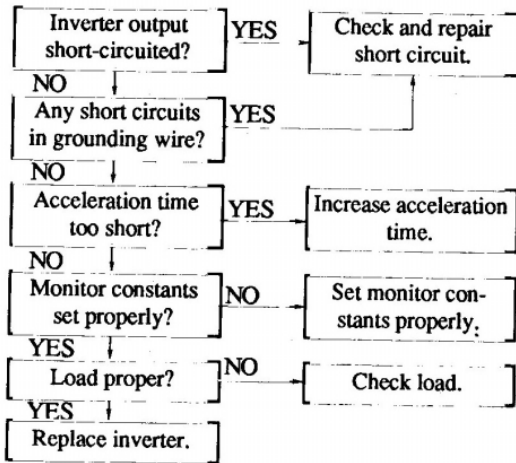

### 5.2.4 *IGbt* flashes

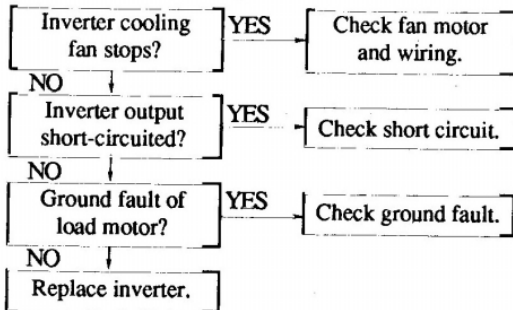

### 5.2.6 *Fv* flashes

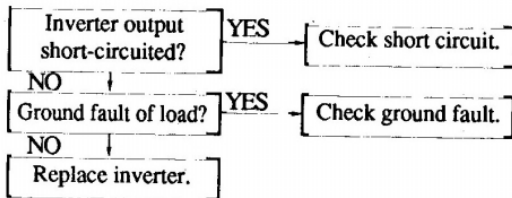

### 5.2.8 Motor rotates unsmoothly

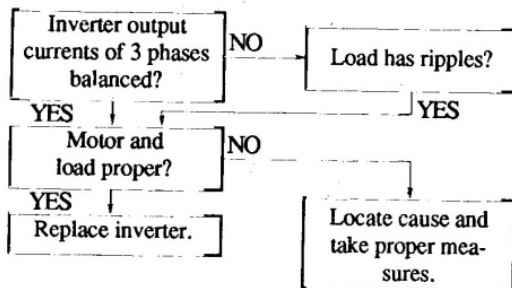

### 5.2.3 *ou* flashes

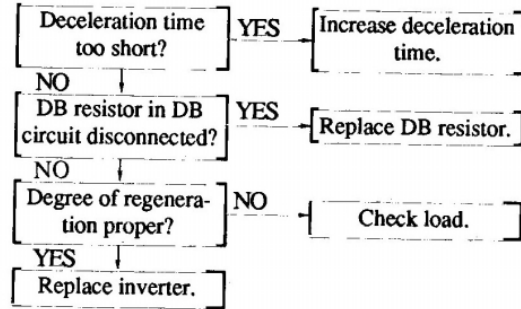

### 5.2.5 *oL* flashes

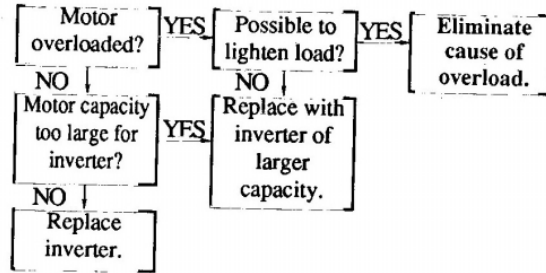

### 5.2.7 Motor speed cannot be varied

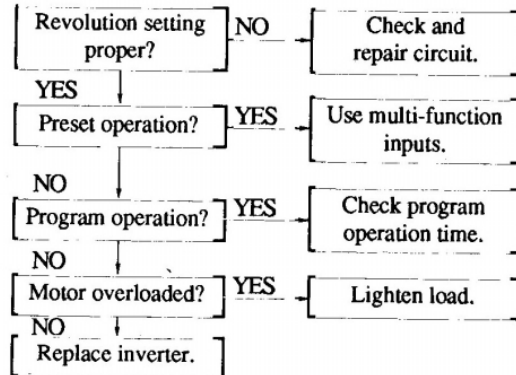

### 5.2.9 *OH* flashes

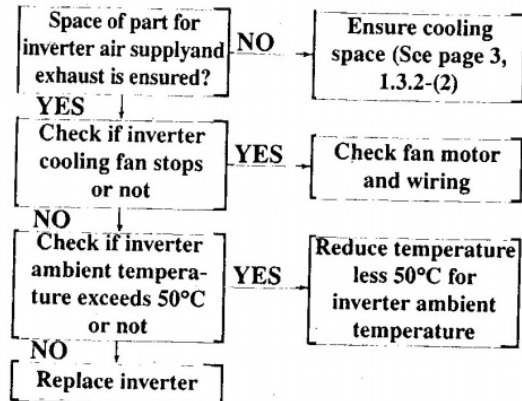

### 5.3 Phase Failure of Input Power Source

If the inverter is operated for a long time under phase failure, the inverter's service life may be shortened remarkably. Use care.

## 6. Inspection and Maintenance

### 6.1 Periodical Inspection

In order to maintain the inverter in the best conditions and make it demonstrate its full performances, carry out periodical inspection once every six months at least and check any matters which cannot be checked in daily inspection.

The inverter and its peripheral equipment should be inspected by an engineer familiar with safety precautions and proper handling of electric appliances.

### Safety Precautions

1. Turn the inverter power off to avoid electrocution. Open the front cover, and make sure that the CHG LED in the lower part of the printed circuit board is off.
2. Note that the heatsink may be hot in some operating conditions.

### Inspection list

Applicable parts	Check points
Unit casing	Check the ventilation holes and heat sink for dust or foreign matters. Clean them if dusty.
Cooling fan	Check the cooling fan for dust or foreign matters. Clean it if dusty. We recommend that the cooling fan be replaced after 3 to 5 years of operation, provided the inverter is used for 12 hours a day.
Inside of unit	Check the printed circuit board and other electronic parts for dust or foreign matters. Clean them if dusty.
Terminal blocks & set screws	Check the terminal blocks and set screws for looseness. Retighten them if loose.
Connectors	Check the connectors and terminals of the control PCB for looseness.
Wiring	Check the insulating covering of the wires for cracks, deformation or other defects.
Electrolytic capacitors	Check the electrolytic capacitors for leakage of electrolyte, discoloration or other defects. Replace it if some abnormalities are found. The capacitors should be replaced every five years, provided the inverter is used for 10 hours a day at the average ambient temperature of 35°C. (See Note below)

Note: Before using spare capacitors which have been stored for three years or more, mount them in the inverter, disconnect the output cable from the inverter, and apply rated AC current to the inverter for eight hours for aging of the capacitors.

## 6.2 Insulation resistance test

- (1) Clean all parts of the inverter, disconnect all wires, and short circuit the terminals of the terminal block TB1 on the main printed circuit board. Use a 500VDC megger for insulation resistance test. (Do not attempt an insulation resistance test at the terminals of the control circuit.)
- (2) On completion of preparation, measure insulation resistance between the terminals and GND terminal of TB1 on the main printed circuit board.
- (3) On completion of testing, remove the shorting wire and connect all connectors with care not to miss them. If the power is turned on with some connectors improperly connected, parts may be damaged.

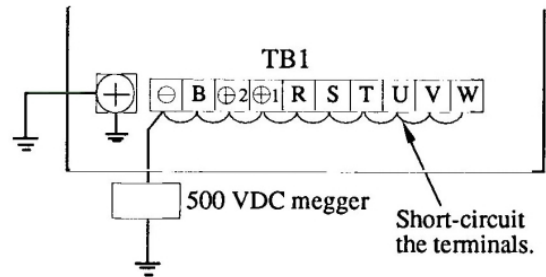

## 6.3 Precautions for replacing Printed Circuit Board

When the printed board VFC61 is replaced with a spare board, input the previously-used function set values from the console.

## 6.4 Disposal

Dispose of replaced parts and/or spare parts in conformance to the administrative regulations and ordinances.

Request to distributors:

If you deliver your product incorporating with this inverter equipment, supply this manual to the end user. In case you change the data of inverter set at the factory, inform end user of that details.

# 7.1 VF61 Enclosure Dimensions

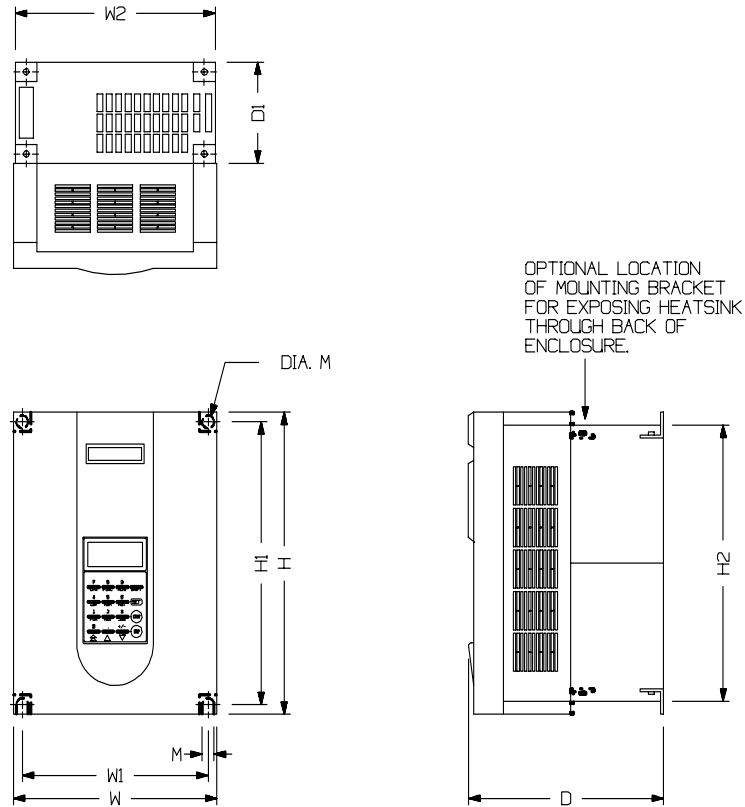

Type	W	W1	W2	D	D1	H	H1	M	WEIGHT (LBS)
VF61-2R222	5.90	5.12	5.71	7.68	3.55	11.83	11.23	.25	7.7
VF61-3R722	5.90	5.12	5.71	7.68	3.55	11.83	11.23		7.7
VF61-5R522	8.67	7.88	8.47	8.27	3.94	11.83	11.23		12.1
VF61-7R522	8.67	7.88	8.47	8.27	3.94	11.83	11.23		12.54
VF61-1122	9.85	7.88	9.53	9.46	5.32	16.14	15.55		37.4
VF61-1522	9.85	7.88	9.53	9.46	5.32	16.14	15.55		37.4
VF61-2222	11.82	9.85	11.50	9.46	5.32	18.10	17.50	48.4	
VF61-3022	16.93	14.17	16.61	10.63	6.61	22.64	21.85	0.375	85.8
VF61-3722	16.93	14.17	16.61	10.63	6.61	22.64	21.85		85.8
VF61-4522	20.87	16.14	20.87	11.81	6.7	23.62	22.64		94.6
VF61-5522	20.87	16.14	20.87	11.81	6.70	23.62	22.64		94.6
VF61-7522	20.87	16.14	20.87	13.78	-	28.35	27.36		160.6
VF61-9022	24.41	20.89	24.41	13.78	-	30.31	29.33		202.4
VF61-2R244	5.90	5.12	5.71	7.68	3.55	11.83	11.23	.250	7.7
VF61-3R744	5.90	5.12	5.71	7.68	3.55	11.83	11.23		7.7
VF61-5R544	8.67	7.88	8.47	8.27	3.94	11.83	11.23		11
VF61-7R544	8.67	7.88	8.47	8.27	3.94	11.83	11.23		11.44
VF61-1144	9.85	7.88	9.53	9.46	5.32	16.14	15.55		37.4
VF61-1544	9.85	7.88	9.53	9.46	5.32	16.14	15.55		37.4
VF61-2244	11.82	9.85	11.50	9.46	5.32	18.10	17.50	48.4	
VF61-3044	16.93	14.17	16.61	10.63	6.61	22.64	21.85	.375	85.8
VF61-3744	16.93	14.17	16.61	10.63	6.61	22.64	21.85		85.8
VF61-4544	20.87	16.14	20.87	11.81	6.70	23.62	22.64		94.6
VF61-5544	20.87	16.14	20.87	11.81	6.70	23.62	22.64		94.6
VF61-7544	20.87	16.14	20.87	13.78	-	28.35	27.36		138.6
VF61-11044	24.41	20.89	24.41	13.78	-	30.31	29.33		180.4
VF61-16044	19.7	16.14	19.7	13.78	-	39.37	38.39	209	
VF61-20044	19.7	16.14	19.7	13.78	-	47.24	46.25	286	
VF61-25044	19.7	16.14	19.7	13.78	-	47.24	46.25	330	

All dimensions in inches. All weights in lbs.

Drivecon reserves the right to change information contained within due to ongoing product development.

# 7.2 Typical Wiring Diagram

## VF61 TYPICAL WIRING DIAGRAM

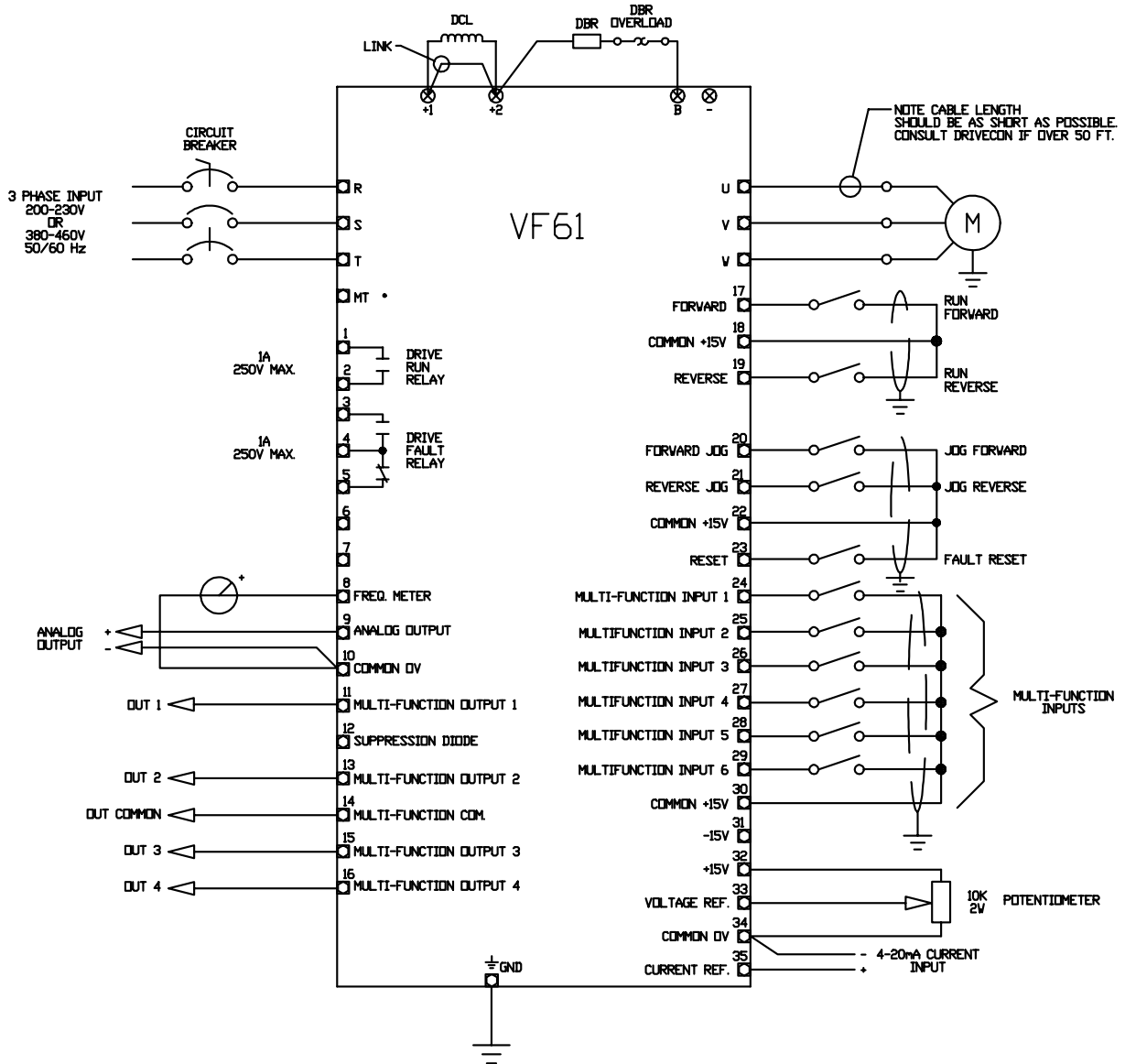

NOTE: TERMINALS 18,22,30 ARE COMMON WITHIN DRIVE  
 REMOVE LINK AT +1 AND +2 WHEN USING DCL.  
 \* TERMINALS MR AND MT ARE EQUIPPED ON MODELS OVER 11KW

## 7.3 Operator Unit Dimensions

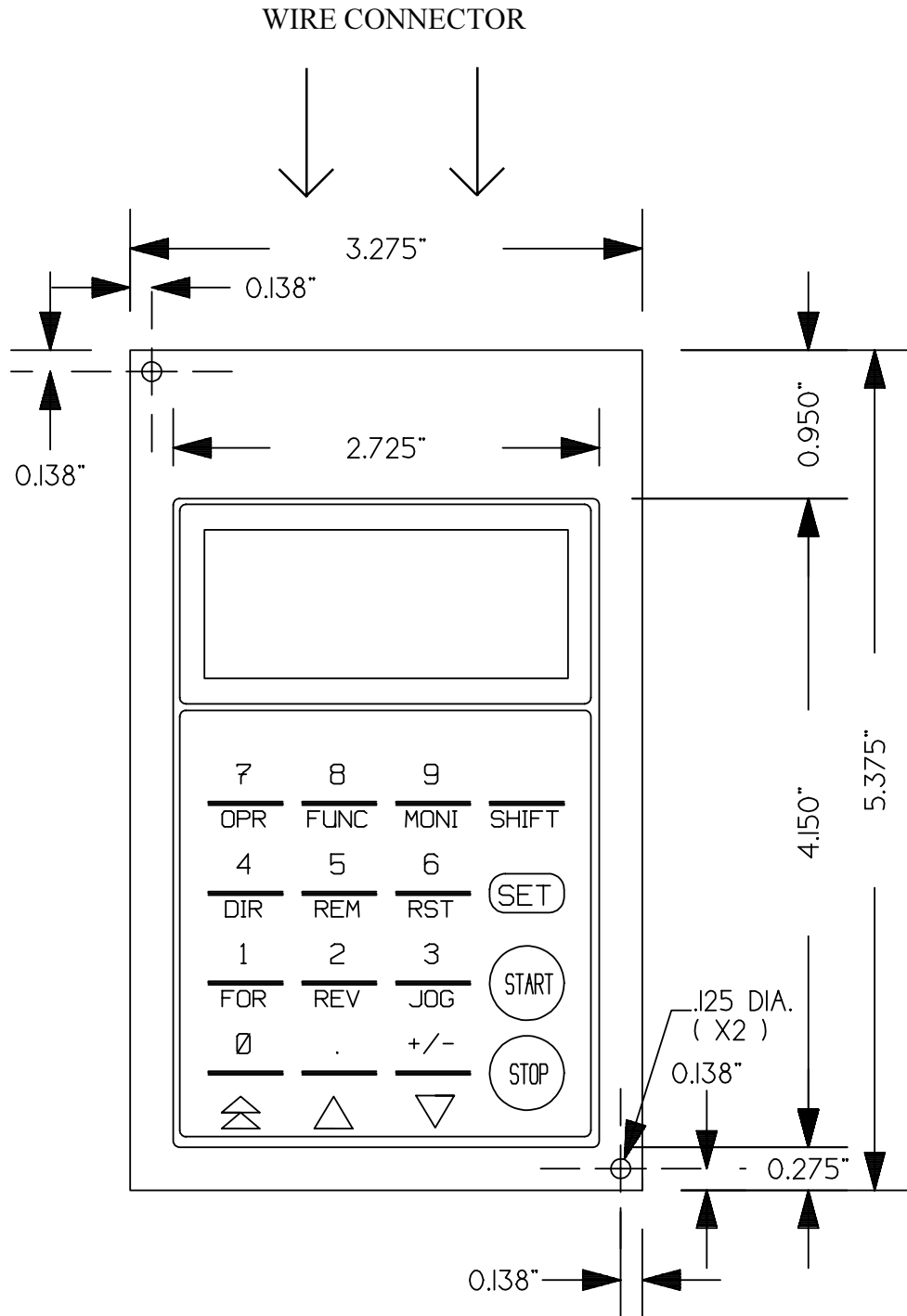

## 7.4 Standard Specifications

Model VF61-		200V Series										
		2R22	3R72	5R52	7R52	1122	1522	2222	3022	3722	4522	5522
Rated output	Motor (HP) *1	3	5	25	10	15	20	30	40	50	60	75
	Capacity (kVA)	4.0	6.8	9.5	12.9	18.3	24.8	34.6	48.1	58	73.6	88.3
	Current (A)	10	17	24	32.5	46	62.5	87	121	146	185	222
	Voltage (V)	200~230V (according to input voltage)*2										
Input	Rated voltage/freq.	3 phase 3 wires 200~230V +/- 10% 50/60 Hz +/- 5%										
	Input power factor	Approx. 0.7 (without DCL) More than 0.9 (with DCL) *3										
	Input capacity (kVA)	4.4	7.5	10.4	14.9	20.1	27.2	38.0	52.9	63.8	80.9	97.3
DC Reactor		Option					1522	2222	3022	3722	4522	5522
Cooling method		Forced cooling										
Model VF61-		400V Series										
		2R24	3R74	5R54	7R54	1144	1544	2244	3044	3744	4544	5544
Rated output	Motor (HP) *1	3	5	7.5	10	15	20	30	40	50	60	75
	Capacity(kVA)	4.4	7.3	10.3	13.5	19.1	25.8	36.6	49.7	60	73.3	83.3
	Current (A)	5.5	9.2	13	17	24	32.5	46	62.5	75.5	92.5	111
	Voltage (V)	380~460V (according to input voltage)*2										
Input	Rated voltage/freq.	3 phase 3 wires 380~460V +/- 10% 50/60 Hz +/- 5%										
	Input power factor	Approx. 0.7 (without DCL) More than 0.9 (with DCL) *3										
	Input capacity (kVA)	4.1	7.0	10.3	14	20.5	28	40.2	54.6	60	80.9	91.6
DC Reactor		Option					2244	3044	3744	4544	5544	
Cooling method		Forced cooling										

\*1 Motor is general purpose type with 4 poles, in case of larger size motor, more than 75 HP, please refer to Drivecon.

\*2 Output voltage can not exceed input AC voltage.

\*3 Varies depending on impedance value of power supply.

## 7.5 VF61 Programming Chart

VF61 Programming Chart								
Model VF61 _____ SN: _____								
Basic Settings								
Code No.	Function Abbrev.	Function setting item	Unit	Setting range (Setting Resolution)		Change during operation	Default	User value
0	Ref(set)F	Ref., set frequency	Hz	-TopF to +TopF		Possible	0Hz	
1	FOR-JOG.F	Forward jog frequency	Hz	0-30		Possible	5Hz	
2	REV-JOG.F	Reverse jog frequency	Hz					
3	Preset 1.F	Preset (1) frequency	Hz	-TopF to +TopF		Possible Impossible	0Hz	
4	Preset 2.F	Preset (2) frequency	Hz					
5	Top.F	Maximum frequency	Hz	F max to 400		Impossible	60Hz	
6	PC-Base.F	Power control (base) frequency	Hz	30 to TopF		Impossible	60Hz	
7	Rated.Out.V	Rated output voltage	V	(400V class)	280-500V	Possible	400V	
			V	(200V class)	140-250V		200V	
8	Accl. Time	Acceleration (1) time	sec	0.1 to 3600		Impossible	30sec	
9	Decl. Time	Deceleration (1) time						
10	Torq. Boost	Torque boost quantity	%	0 to 20		Possible	0%	
11	Min. F	Minimum frequency	Hz	0 to 10		Possible	.5Hz	
12	OL.Set	Overload rate	%	80 to 110		Possible	100%	
13	V/F.Pattern	V/F pattern selection	N/A	linear sq-r-law bend	V/F linear (a) V/F square law reduction (b) V/F bend (c)	Impossible	(a)	
14	Start mode	Start mode selection	N/A	Min F start free start	Minimum frequency start (a) Free start (b)	Impossible	(a)	
15	Stop mode	Stop mode selection	N/A	decel stop free stop	Deceleration stop (a) Free stop (b)	Impossible	(a)	
16	Function up	Selection of special setting items	N/A	Sp. set - 1	Special setting 1 (a)	Possible	(a) N/A	
				Sp. set - 2	Special setting 2 (b)			
				Option	Optional setting (c)			
Special settings Sp.set1								
17	Lim. F (Upper)	Frequency limit (upper)	%	Lim.F(L) to 100		Impossible	100%	
18	Lim. F (Lower)	Frequency limit (lower)	%	0.0 to Lim.F(U)		Impossible	0%	
19	Ex. Ref. F Sel	Selection of external frequency setting	N/A	-10 to 0 to 10v 4 to 20mA	Setting=voltage (a) Setting=current (b)	Impossible	(a)	
20	Ex. Ref. F Char	Characteristics of external frequency setting	N/A	0 Hz to TOP.F Lim.L to Lim-U	Normal (a) Limit reference (b)	Impossible	(a)	
21	OF. Set	Over frequency fault	Hz	30 to 500 Hz		Possible	65 Hz	
22	Boost.Mode	Boost mode selection	N/A	Manual Auto	Manual boost (a) Automatic boost (b)	Impossible	(a)	
23	Bend-Point.V	Bend point voltage for V/F bend (% of rated output)	%	0 to 99.9%		Impossible	0%	
24	Bend-Point.F	Bend point frequency for V/F bend	Hz	0 to PC-Base.F		Impossible	0 Hz	
25	Lim.Torq.SW	Torque limit switch	N/A	P-off, B-off P-on, B-off P-off, B-on P-on, B-on	Both power and braking off (a) Only power is on (b) Only braking is on (c) Both power and braking on (d)	Impossible	(a)	

VF61 Programming Chart								
Model VF61 _____ SN: _____								
Code No.	Function Abbrev.	Function setting item	Unit	Setting range (Setting Resolution)		Change during operation	Default	User value
26	Lim.Torq (P)	Power torque limit	%	20 to 150		Possible	150%	
27	Lim.Torq (B)	Braking torque limit	%	0 to 150		Possible	150%	
28	DC-Br.V	DC brake voltage (/rating x 100)	%	0 to 20		Possible	0%	
29	DC-Br.F	DC brake start frequency at time of deceleration stop	Hz	.5 to 10		Possible	1 Hz	
30	DC-Br.Time	DC brake time at the time of deceleration stop	Sec	0 to 5		Possible	0 Sec	
31	Jump.1.F	Jump (1) Frequency	Hz	0 to Top.F		Possible	0 Hz	
32	Jump.2.F	Jump (2) Frequency	Hz	0 to Top.F		Possible	0 Hz	
33	Jump.3.F	Jump (3) Frequency	Hz	0 to Top.F		Possible	0 Hz	
34	Jump.F.Band	Jump frequency band	Hz	0 to 10		Possible	0 Hz	
35	SAcc.St.Sel	S-shape acceleration start selection	Sec	0 Sec (a)		Impossible	(a)	
36	SAcc.End.Sel	S-shape acceleration end (settling) selection	Sec	1 Sec (b)		Impossible	(a)	
37	SDec.St.Sel	S-shape deceleration start selection	Sec	5 Sec (c)		Impossible	(a)	
38	SDec.End.Se	S-shape deceleration end (settling) selection	Sec	10 Sec (d)		Impossible	(a)	
39	Rotation.Sel	Rotation direction selection	N/A	For/Rev Both allowed (a) For only (b) Rev only (c)	Both forward and reverse reverse rotation is inhibited Forward rotation is inhibited	Impossible	(a)	
40	IPF.Restart	'Restart after instantaneous power failure' selection	N/A	off (a) on (b)	ower failure lasting 10 seconds or less is * assumed to be instantaneous power failure	Impossible	(a)	
41	Restart.Time	Restart time	Sec	.1 to 5 sec.		Impossible	1 Sec.	
42	Retrial.Cnt	Retry count	N/A	0 to 5		Impossible	0	
43	F.Control	Frequency control mode selection	N/A	Standard (a) Slip Compen. (b) Freq. Droop (c) ASR Control (d)	Open control Slip compensation control Frequency droop control ASR control	Impossible	(a)	
44	Droop	Frequency droop quantity (expressed as % of Top.F)	%	0 to 10%		Impossible	0%	
45	PGM.Drive	Program operation selection	N/A	off (a) on (b)		Impossible	(a)	
46	PGM.Time.Se	Program operation time unit selection	N/A	sec. (a) min. (b) hour (c)	Second Minute Hour	Possible	(a)	
47	PGM-0.Time	Program operation (0) time	N/A	1 to 1000		Possible	1	
48	PGM-1.Time	Program operation (1) time	N/A	0 to 1000		Possible	0	
49	PGM-2.Time	Program operation (2) time	N/A	0 to 1000		Possible	0	
50	PGM-3.Time	Program operation (3) time	N/A	0 to 1000		Possible	0	
51	PGM-4.Time	Program operation (4) time	N/A	0 to 1000		Possible	0	

**VF61 Programming Chart**

Model VF61 \_\_\_\_\_ SN: \_\_\_\_\_

Code No.	Function Abbrev.	Function setting item	Unit	Setting range (Setting Resolution)	Change during operation	Default	User value		
52	PGM-5.Time	Program operation (5) time	As set in Code 46	0 to 1000	Possible	0			
53	PGM-6 Time	Program operation (6) time		0 to 1000	Possible	0			
54	PGM-7 Time	Program operation (7) time		0 to 1000	Possible	0			
55	PGM0.Acc/Dec	Program operation (0) acceleration/deceleration selection	Sec.	Acc1/Dec1 Code # 08,09 are used (a) Acc2/Dec2 Code # 80,81 are used (b) Acc3/Dec3 Code # 82,83 are used (c) Acc4/Dec4 Code # 84,85 are used (d)	Possible	(a)			
56	PGM1.Acc/Dec	Program operation (1) acceleration/deceleration selection				(a)			
57	PGM2.Acc/Dec	Program operation (2) acceleration/deceleration selection				(a)			
58	PGM3.Acc/Dec	Program operation (3) acceleration/deceleration selection				(a)			
59	PGM4.Acc/Dec	Program operation (4) acceleration/deceleration selection				(a)			
60	PGM5.Acc/Dec	Program operation (5) acceleration/deceleration selection				(a)			
61	PGM6.Acc/Dec	Program operation (6) acceleration/deceleration selection				(a)			
62	PGM7.Acc/Dec	Program operation (7) acceleration/deceleration selection				(a)			
63	Ref.F.Sel	Frequency setting operation place selection	N/A	Dir/Rem (a) Terminal Console (c) Option -1 (d) Option -2 (e) Up/Down key (f) Up/Down Term (g)	Impossible	(a)			
64	START-SW.Se	Start switch operation place selection		Dir/Rem (a) Terminal Console (c) Option -1 (d) Option -2 (e)			Impossible	(a)	
65	JOG-SW.Sel	Jog switch operation place selection		Dir/Rem (a) Terminal Console (c) Option -1 (d) Option -2 (e)					(a)
66	Term-11.Sel	Terminal 11 (multi-function output) function selection	N/A	Arrive Ref.F (a) F- Detect 1.F (b) F> - Detect 1.F (c) F< - Detect 1.F (d) F- Detect 2.F (e) F> - Detect 2.F (f) F< - Detect 2.F (g) T> - Detect.T (h) OL.Pre.Alarm (i) Under Volt (j) Reverse Now progress (k) Remote Now progress (l) Retrial Now (m) P.time Over (n) Alarm Code (o)	Possible	(a)			
67	Term-13.Sel	Terminal 13 (multi-function output) function selection		Set value is reached (a) Frequency detection(1) (b) Frequency detection (1) (c) Frequency detection (1) (d) Frequency detection (2) (e) Frequency detection (2) (f) Frequency detection (2) (g) Torque detection (h) Overload Pre-alarm (i) Insufficient voltage (j) Reverse rotation in progress (k) Remote selection in progress (l) Retry in progress (m) PGM operation is finished (n) Alarm Code (o)			(c)		
68	Term-15.Sel	Terminal 15 (multi-function output) function selection		(h)					
69	Term-16.Sel	Terminal 16 (multi-function output) function selection		(j)					
70	Detect 1.F	Detected frequency (1)		Hz			0 to Top.F	Possible	0 Hz
71	Detect 2.F	Detected frequency (2)	Hz	0 to 10	Possible	0 Hz			
72	DetectF.Band	Frequency band detection	Hz	0 to 10	Possible	0 Hz			
73	Detect.Torq	Torque detection	%	-150 to 150	Possible	100%			
74	Term-24.Sel	Terminal 24 (multifunction input) function select	N/A	Preset Sel.1 (a) Preset Sel.2 (b) Preset Sel.3 (c) Acc/Dec Sel1 (d) Acc/Dec Sel2 (e) F.Up (f) F.Down (g) Ext. Failure 1 (h) Ext. Failure 2 (i) Ext. Failure 3 (j) Ext. Failure 4 (k) DC-Brake (l) F.Hold (m) P-Timer Next (n) Emerg.Stop-A (o) Emerg.Stop-B contact (p)	Impossible	(a)			
75	Term-25.Sel	Terminal 25 (multifunction input) function select		Accel./decel. selection (d) Accel./decel. selection (e) frequency up (f) frequency down (g) External failure 1 (h) External failure 2 (i) External failure 3 (j) External failure 4 (k) DC brake switch (l) Frequency Hold (m) Go to next PGM step (n) Emergency stop n.o. contact (o) Emergency stop n.c. (p)			(b)		
76	Term-26.Sel	Terminal 26 (multifunction input) function select		(d)					
77	Term-27.Sel	Terminal 27 (multifunction input) function select		(h)					
78	Term-28.Sel	Terminal 28 (multifunction input) function select		(i)					
79	Term-29.Sel	Terminal 29 (multifunction input) function select		(o)					

**VF61 Programming Chart**  
 Model VF61 SN: \_\_\_\_\_

Code No.	Function Abbrev.	Function setting item	Unit	Setting range (Setting Resolution)	Change during operation	Default	User value
80	Acc2.Time	Acceleration (2) time	Sec.	.1 to 3600	Impossible	30 Sec	
81	Dec2.time	Deceleration (2) time					
82	Acc3.Time	Acceleration (3) time					
83	Dec3.Time	Deceleration (3) time					
84	Acc4.Time	Acceleration (4) time					
85	Dec4.Time	Deceleration (4) time					
86	Preset3.F	Preset (3) frequency	Hz	-Top.F to +Top.F	Possible	0 Hz	
87	Preset4.F	Preset (4) frequency					
88	Preset5.F	Preset (5) frequency					
89	Preset6.F	Preset (6) frequency					
90	Preset7.F	Preset (7) frequency					
91	Term-9.Sel	Terminal 9 (multifunction analog output) selection	N/A	Vout Iout Torq current(c) Fout Internal Mon use (e)	Output voltage (a) Output current (b) Torque Output frequency (d) justing monitor for internal	Possible	(b)
92	Carrier.F	Carrier frequency	kHz	4 to 15	Possible	15 kHz	
93	L-SP.Adjust	Line speed indication adjustment	N/A	0 to 3200	Possible	0	
94	STB.Adjust	STB adjustment	%	0 to 100	Possible	0%	
95	OL.Pre-Alarm	Overload pre-alarm setting	%	0 to 100	Possible	50%	
96	LED-Disp.Sel	Inverter LED indication item selection	N/A	Fout Fref Iout Vout Torq out Vdc Motor Speed OL counter Line Speed ROM Version j)	Output frequency (a) Reference frequency (b) Output current (c) Output voltage (d) Torque current (e) DC voltage (f) Synchronous motor RPM (g) Overload counter (h) Line Speed (i) ROM Version	Possible	(a)
97	ALM-data cir	Fault history clear	N/A	yes (a) no (b)	Impossible	(b)	

**Code group special settings**

Code No.	Function Abbrev.	Function setting item	Unit	Setting range (Setting Resolution)	Change during operation	Default	User Value
17	Motor.Cap	Rated motor capacity	kW	4 to rated inverter capacity	Impossible	N/A	
18	Motor.V	Rated motor voltage	V	(400V class) 320 to 480	Impossible	400V	
			V	(200V class) 160 to 240	Impossible	200V	
19	Motor.I	Rated motor current	A	1 to Rated inverter current	Impossible	N/A	
20	Motor.F	Rated motor frequency	Hz	30 to 400	Impossible	60Hz	
21	Motor.RPM	Rated motor RPM	rpm	300 to 24000	Impossible	1740rpm	
22	Motor.Pole	Number of poles of the motor	N/A	2,4,6,8 (pole)	Impossible	N/A	
23	Motor.R1drop	Primary resistance drop of the motor	%	0 to 25	Impossible	5%	
24	DB.V	Dynamic Brake operating voltage	V	(400V class) 540 to 740	Possible	720V	
			V	(200V class) 270 to 370	Possible	360V	
25	0 to 10V Gain	Frequency setting input + side (0V to 10V) gain	%	50 to 150	Possible	100%	
26	-10 to 0V Gain	Frequency setting input - side (-10V to 0V) gain	%	50 to 150	Possible	100%	
27	Term-9.Gain	Terminal 9 (analog output) gain	%	50 to 150	Possible	100%	
28	Term-9.Offset	Terminal 9 (analog output) offset	%	-5 to +5	Possible	0%	
29	VDC.DET.Gain	DC voltage detection gain	%	90 to 110	Possible	100%	
30	CRT.DET.Gain	Output current detection gain	%	50 to 150	Possible	100%	
31	FCL.Level	FCL level	%	80 to 100	Possible	100%	

**Special Setting 2 (Sp.set-2)**

Code No.	Function Abbrev.	Function setting item	Unit	Setting range (Setting Resolution)	Change during operation	Default	User Value
17	4 to 20 out.Sel	4 to 20 mA output selection	N/A	Vout Iout Torq Fout Internal Mon use (e)	Output voltage (a) Output current (b) Torque current (c) Output frequency (d) Adjustment monitor for internal	Possible	(b)
18	4 to 20 out.gain	4 to 20 mA output gain	%	50 to 150	Possible	100%	
19	4 to 20 out.Offset	4 to 20 mA output offset	%	-1 to +1	Possible	0%	
20	ISOIn.Gain	Insulated input gain	%	50 to 150	Possible	100%	
21	ISOIn.Offset	Insulated input offset	%	-1 to +1	Possible	0%	
22	PG-Pulse	Number of PG pulses	P/R	100 to 2400	Impossible	600 P/R	
23	ASR.P-Gain	ASR proportional gain	N/A	1 to 200	Possible	5	
24	ASR.I-Time	ASR integral time	mS	.20 to 200	Possible	10 mS	

### VF61 Console Monitor Indications

Code No.	LCD indication	Monitor Indications	Unit	Remarks
0	Fout	Output frequency	Hz	
1	Fref	Reference frequency	Hz	
2	Iout	Output current	A	
3	Vout	Output voltage	V	
4	Torq out	Torque (torque current)	%	Current for the same phase as the output voltage is indicated.
5	Vdc	DC voltage	V	
6	Motor Speed	Synchronous speed	rpm	For ASR operation, number of rotations indicated. For other operation, frequency obtained based on the number is indicated.
7	OL counter	Overload counter	%	When the rated motor current is exceeded, the counter starts counting. After this, when the counter reaches 100%, the overload protection activates. (When OL.SET=100%)
8	Line Speed	Line speed	-	Value obtained in No. 93 is indicated.
9	I1 term check	Input terminal check 1	bit	1 is indicated by terminal block on.
10	I2 term check	Input terminal check 2	bit	1 is indicated by terminal block on.
11	O- term check	Output terminal check	bit	1 is indicated by terminal block on.
15	ROM version	ROM version	-	"XX-XX" of ROM software version VF61-XX-XX is displayed through conversion of alphabetic characters into numeric characters like A=0, B=1, and so forth.
17	Trouble moni	Protection history	-	The contents of the last 5 protection and the current and voltage at the time of the protection are indicated.

## **7.6 D61532 (D61533) Input Signal Isolator Board instructions**

**D61532 110vac Input Signal Isolator Board  
P/N 10561532 PCB Revision 1  
D61533 24vac Input Signal Isolator Board  
P/N 10561533 PCB Revision 1**



**For use with Drivecon VF6100 Standard or VF61V/S Flux Vector series of variable frequency drives**

**Introduction**

The D61532 / D61533 Input Signal Isolator Boards are for use with Drivecon VF6100 Standard or VF61V/S Flux Vector series of variable frequency drives. They are designed to accept external 110vac or 24vac inputs from switch or relay contacts. The D61532 will accept 110-120vac signals and the D61533 will accept 24vac input signals. The D61532 will not function with 24vac input signals and the D61533 will be damaged if used with 110vac input signals.

Either model of input isolator boards will provide direction [run forward / run reverse] and up to 4 additional preset speeds. Another input is assigned as an external fault reset. Two additional inputs can be assigned individual functions from a list of 16 programmable functions. Also available are two separate relay outputs that can be individually assigned separate functions from a list of 15 programmable functions. Each input has a red LED indicator that illuminates when the input is active and is optically isolated from the VFD main control board. Each programmable relay output has a green LED indicator that illuminates when the output is active. Each relay has “dry” form C contacts available at the terminal strip for external use. There are also two slowdown travel limit switch inputs, one for each direction that will cause the VFD to slow down to the programmed minimum speed level in the affected direction. Normal travel and speed control are still available for the other direction. The slowdown limit switch should open to cause the VFD to slowdown. A yellow LED indicator is illuminated when the limit switch is closed indicating normal travel and speed are available.

**Table 1 Basic Program List for VF6100 Standard Variable Frequency Drive**

D61532 / D61533 terminal No.	Code Group	Code number to assign function	Code Group / Code No. to set value
1 Fwd	Basic Setting	Code 63	Code 0
2 Rev	Basic Setting	Code 63	Code 0
3 2 <sup>nd</sup> speed	Sp.Set 1	Code 74	Basic Setting / 3
4 3 <sup>rd</sup> speed	Sp.Set 1	Code 75	Basic Setting / 4
5 4 <sup>th</sup> speed	Sp.Set 1	Code 75	SP1.Set 1 / 86
6 5 <sup>th</sup> speed	Sp.Set 1	Code 76	SP1.Set 1 / 87
7 Prog input 1	Sp.Set 1	Code 77	MFI 4 assign
8 Prog input 2	Sp.Set 1	Code 78	MFI 5 assign
9 Prog input 3	Sp.Set 1	Code 79	MFI 6 assign
10-12 Prog output 1	Sp.Set 1	Code 66	MFO 1 assign
13-15 Prog output 2	Sp.Set 1	Code 67	MFO 2 assign
16 110vac neutral	Not programable	110 v neutral only	For 110v control return
17 Fwd Slowdown Limit	Basic Setting		Code 0
18 Rev Slowdown Limit	Basic Setting		Code 0

**Table 2 Basic Program List for VF61V/S Flux Vector Variable Frequency Drive**

D61532 / D61533 terminal No.	Code Group	Code number to assign function	Code Group / Code No. to set value
1 Fwd	Basic Setting	Code 54	Code 0
2 Rev	Basic Setting	Code 54	Code 0
3 2 <sup>nd</sup> speed	Sp.Set 1	Code 32	PGM.Mode/17
4 3 <sup>rd</sup> speed	Sp.Set 1	Code 33	PGM.Mode/18
5 4 <sup>th</sup> speed	Sp.Set 1	Code 33	PGM.Mode/19
6 5 <sup>th</sup> speed	Sp.Set 1	Code 34	PGM.Mode/20
7 Prog input 1	Sp.Set 1	Code 35	MFI 4 assign
8 Prog input 2	Sp.Set 1	Code 36	MFI 5 assign
9 Prog input 3	Sp.Set 1	Code 37	MFI 6 assign
10-12 Prog output 1	Sp.Set 1	Code 38	MFO 1 assign
13-15 Prog output 2	Sp.Set 1	Code 39	MFO 2 assign
16 110vac neutral	Not programable	110 v neutral only	For 110v control return
17 Fwd Slowdown Limit	Basic Setting		Code 0
18 Rev Slowdown Limit	Basic Setting		Code 0

## Specifications

**Table 3**

110v input level	100 vac minimum	125 vac maximum	½ watt burden - 5mA per input. Red LED illuminates on input activation
110v input isolation	2000 VRMS	Optically isolated	
Relay output 1	Form C contacts rated at 250 vac @ 2 amps	terminal 10 - N/O terminal 11 - N/C terminal 12 - COM	Green LED illuminates on relay pick-up
Relay output 2	Form C contacts rated at 250 vac @ 2 amps	terminal 13 - N/O terminal 14 - N/C terminal 15 - COM	Green LED illuminates on relay pick-up
Power requirements	15 vdc @ 75 mA from VFD main control board	No external DC power required	
Temperature Range	0 - 50° C		
Humidity	Less than 90 %		
Altitude	Less than 3000 ft		
Storage temperature	-20° C to +70° C		

## Wiring Diagram

Refer to Drivecon Drawing Number 61532CON.VCD for electrical connection information.

**CAUTION: This solid state isolator will be damaged if the output (connection to drive terminals) are wired in parallel with any external circuits.**

100

101

102

103

104

105

106

107

108

109

110

111

112

113

114

115

116

117

118

119

120

121

122

123

124

125

126

127

128

129

130

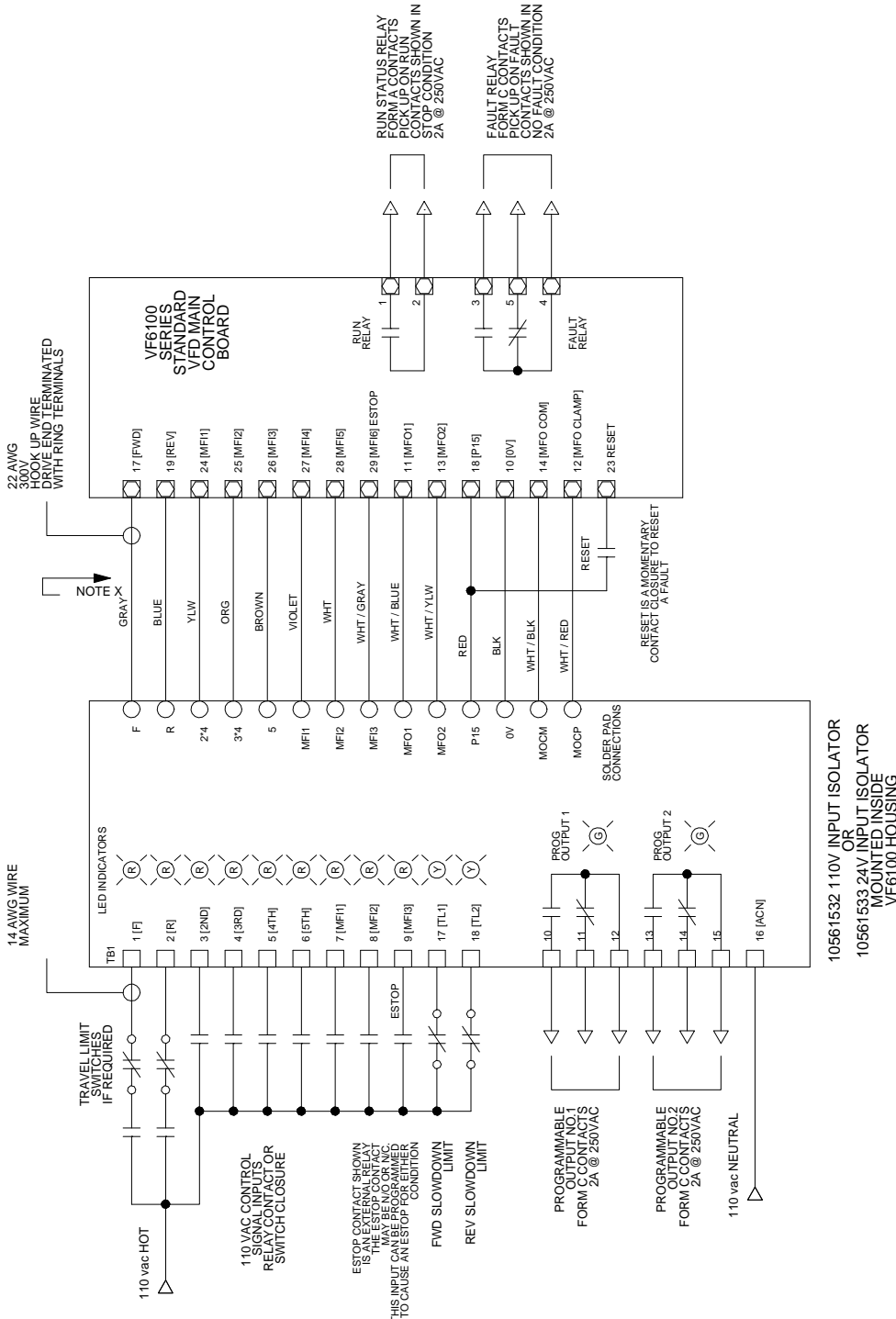

NOTE: DO NOT MAKE ANY EXTERNAL CONNECTIONS IN PARALLEL WITH ISOLATOR PCB'S OUTPUT.

# DRIVECON CORPORATION



820 Lakeside Drive  
Gurnee, IL 60031  
Phone: (847) 855-9150  
Fax: (847) 855-9650

Title: 10561532 110VAC INPUT SIGNAL ISOLATOR BOARD. 10561533 24VAC INPUT SIGNAL ISOLATOR BOARD FOR USE WITH STANDARD VF6100 SERIES VFD CONNECTION DIAGRAM	Date: 09/02/98	REV. #	DATE	COMMENTS
	Designer: RMP	REV.0	9-2-98	GENERAL CONNECTION DIAGRAM.
		REV.1	10-9-98	SLOWDOWN LIMITS ADDED
Location:	Job Number: 61532CON.VCD	REV.2	7/15/00	ESTOP INPUT RELOCATED
Client:		DRAWN BY:		
		CHECKED BY:		

100  
101  
102  
103  
104  
105  
106  
107  
108  
109  
110  
111  
112  
113  
114  
115  
116  
117  
118  
119  
120  
121  
122  
123  
124  
125  
126  
127  
128  
129  
130

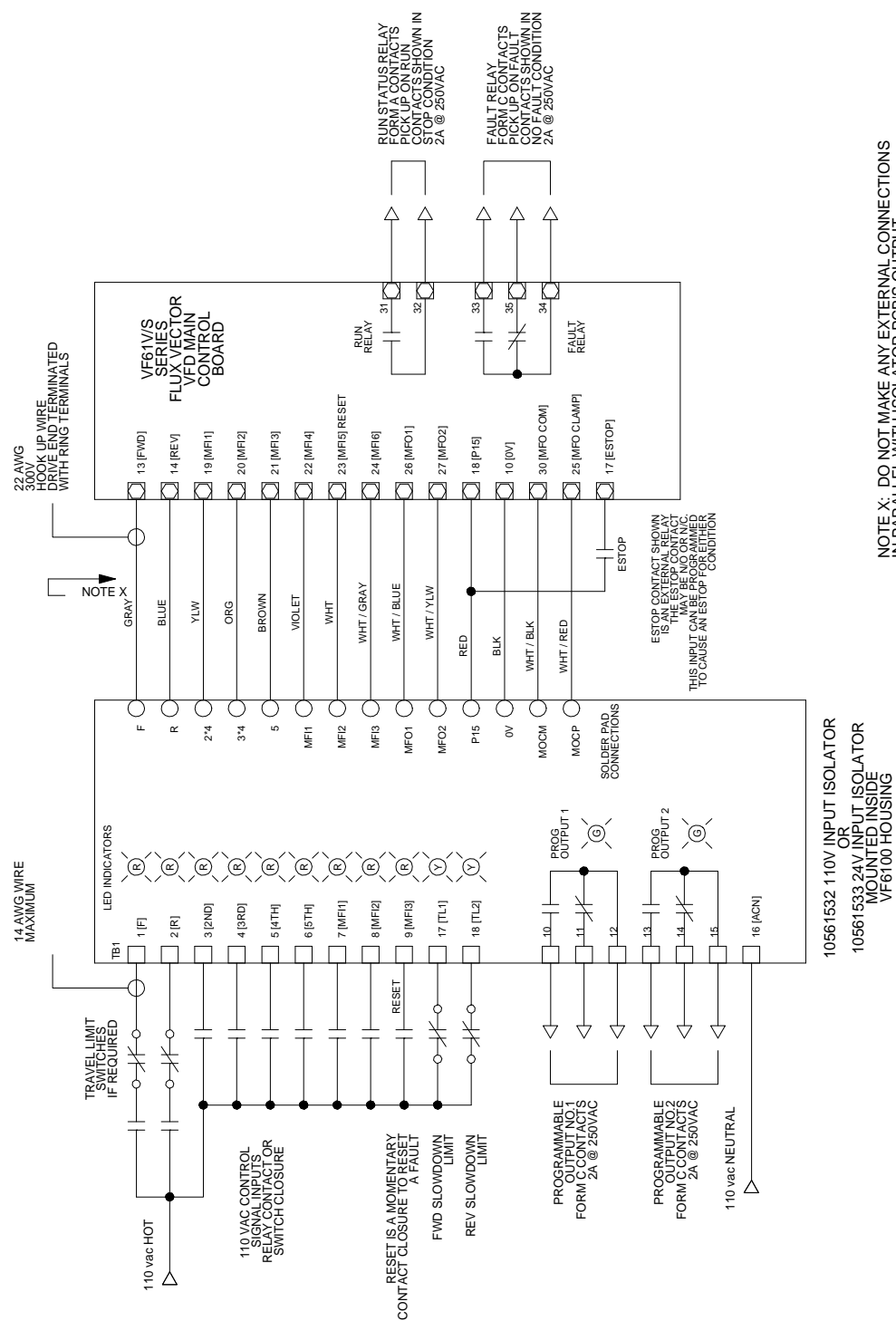

NOTE X: DO NOT MAKE ANY EXTERNAL CONNECTIONS IN PARALLEL WITH ISOLATOR PCB'S OUTPUT.

10561532 110VAC INPUT SIGNAL ISOLATOR BOARD.  
10561533 24VAC INPUT SIGNAL ISOLATOR BOARD.  
FOR USE WITH FLUX VECTOR VF61V/S SERIES VFD  
CONNECTION DIAGRAM

Client: RMP

Location: 61532VCON.VCD

REV. #	DATE	COMMENTS
REV.0	9-2-98	GENERAL CONNECTION DIAGRAM.
REV.1	10-9-98	SLOWDOWN LIMITS ADDED
REV.2	4/26/00	USE WITH VF61V/S
REV.3	7/15/00	RELOCATED RESET INPUT

DRAWN BY: \_\_\_\_\_  
CHECKED BY: \_\_\_\_\_

10561532 110V INPUT ISOLATOR  
OR  
10561533 24V INPUT ISOLATOR  
MOUNTED INSIDE  
VF6100 HOUSING

**DRIVECON CORPORATION**

820 Lakeside Drive  
Gurnee, IL 60031  
Phone: (847) 855-9150  
Fax: (847) 855-9650

A

100  
101  
102  
103  
104  
105  
106  
107  
108  
109  
110  
111  
112  
113  
114  
115  
116  
117  
118  
119  
120  
121  
122  
123  
124  
125  
126  
127  
128  
129  
130  
131  
132  
133  
134  
135  
136  
137  
138  
139  
140  
141  
142  
143  
144  
145  
146  
147  
148  
149  
150

# VF6100 SERIES STANDARD VFD

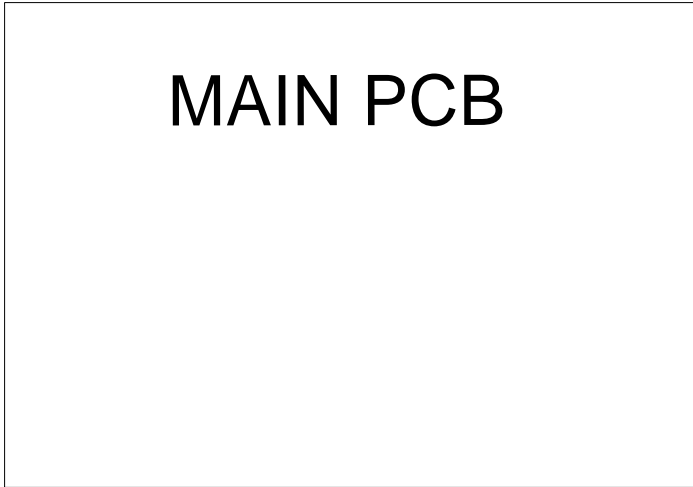

MAIN PCB

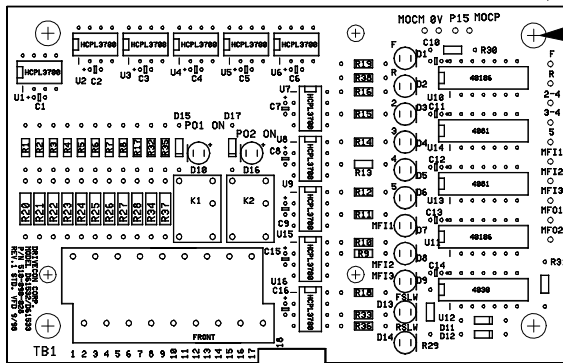

D61532 / D61533  
MOUNTED UNDER FRONT  
COVER OF VFD

DRIVECON CORPORATION



820 Lakeside Drive  
Gurnee, IL 60031  
Phone: (847) 855-9150  
Fax: (847) 855-9650

Date: 9/9/98	REV. #	DATE	COMMENTS
	REV. 0	9/9/98	
Title: D61532 / D61533 SIGNAL ISOLATOR MOUNTING ILLUSTRATION	DESIGNER:	RMP	
	CLIENT:		
Location:	DRAWN BY:	D61532IN.YCD	
	CHECKED BY:		

1020  
1021  
1022  
1023  
1024  
1025  
1026  
1027  
1028  
1029  
110  
111  
112  
113  
114  
115  
116  
117  
118  
119  
120  
121  
122  
123  
124  
125  
126  
127  
128  
129  
130  
131  
132  
133  
134  
135  
136  
137  
138  
139  
140

INSTALL NYLON SUPPORTS AS SHOWN.  
 INSTALLATION OF GROMMET EDGING:  
 FOLLOW INSTALLATION AS SHOWN BELOW.  
 THIS MODIFICATION WILL ELIMINATE  
 POSSIBLE DAMAGE OF D61532 AND D61533.

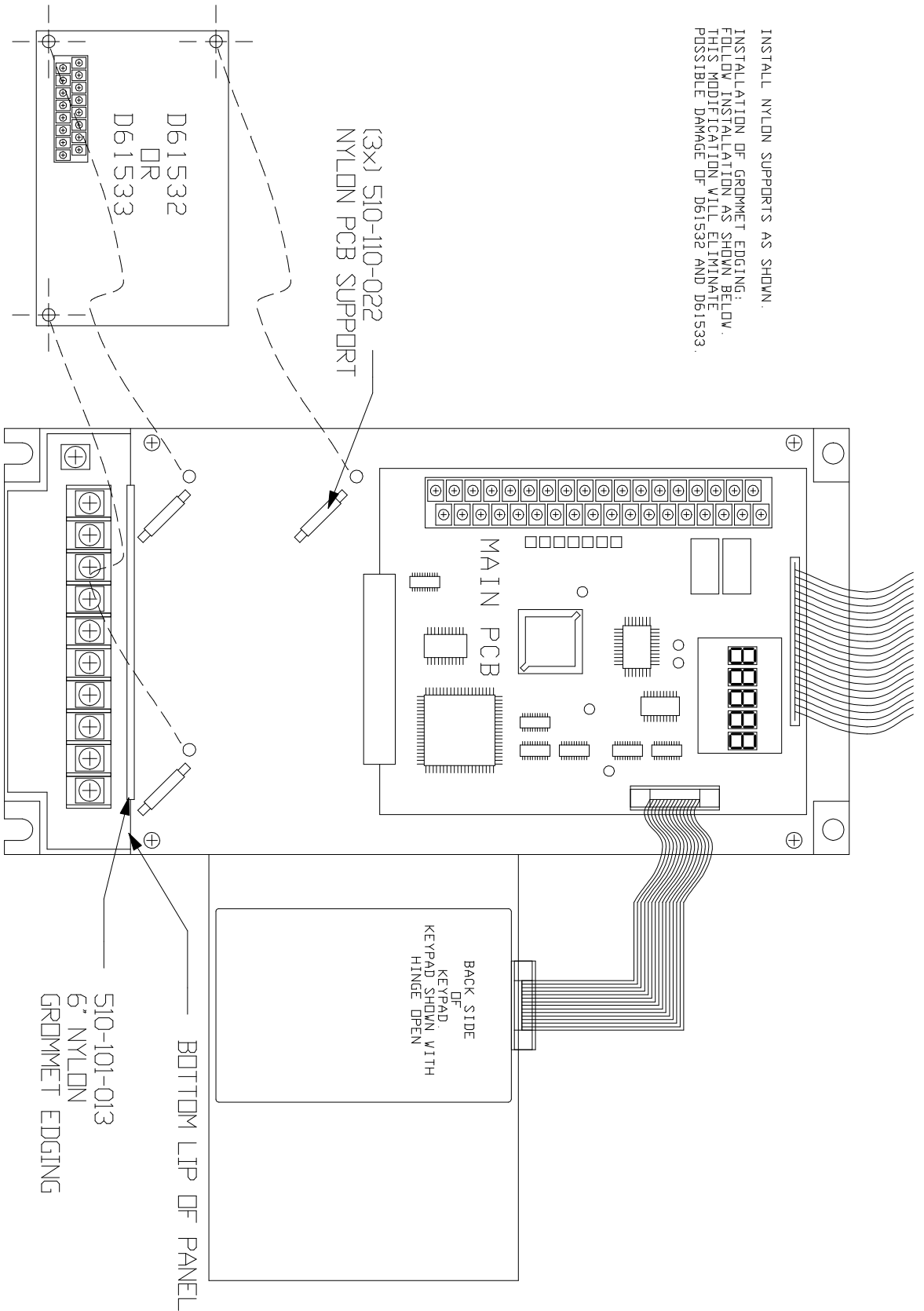



820 Lakeside Drive - Gurnee, IL. 60031  
1-(800) DRIVCON (374-8266)  
PH: (847) 855-9150 FAX: (847) 855-9650  
<http://www.drivecon.com> Email: [sales@drivecon.com](mailto:sales@drivecon.com)